

### 3-PHASE CAPSTAN MOTOR DRIVER

The KA2822D is a monolithic integrated circuit, and suitable for the three-phase spindle motor driver of FDD system.

#### FEATURES

- 3-phase, full-wave, linear BLDC motor driver with 2 hall sensors
- Built-in soft switching drive circuit
- 300 or 360 RPM speed control
- Snubberless
- Built-in chip enable function
- Built-in digital speed control circuit
- Built-in current limit circuit
- Index sensorless
- Built-in TSD (Thermal shutdown)
- Low saturation voltage
- Digital input: TTL, 5V CMOS compatible
- Built-in current-mode control circuit ( $I_{PEAK}$ : 1A)



#### ORDERING INFORMATION

Device	Package	Operating Temperature
KA2822D	28-SSOPH-375	0 ~ 75°C

BLOCK DIAGRAM

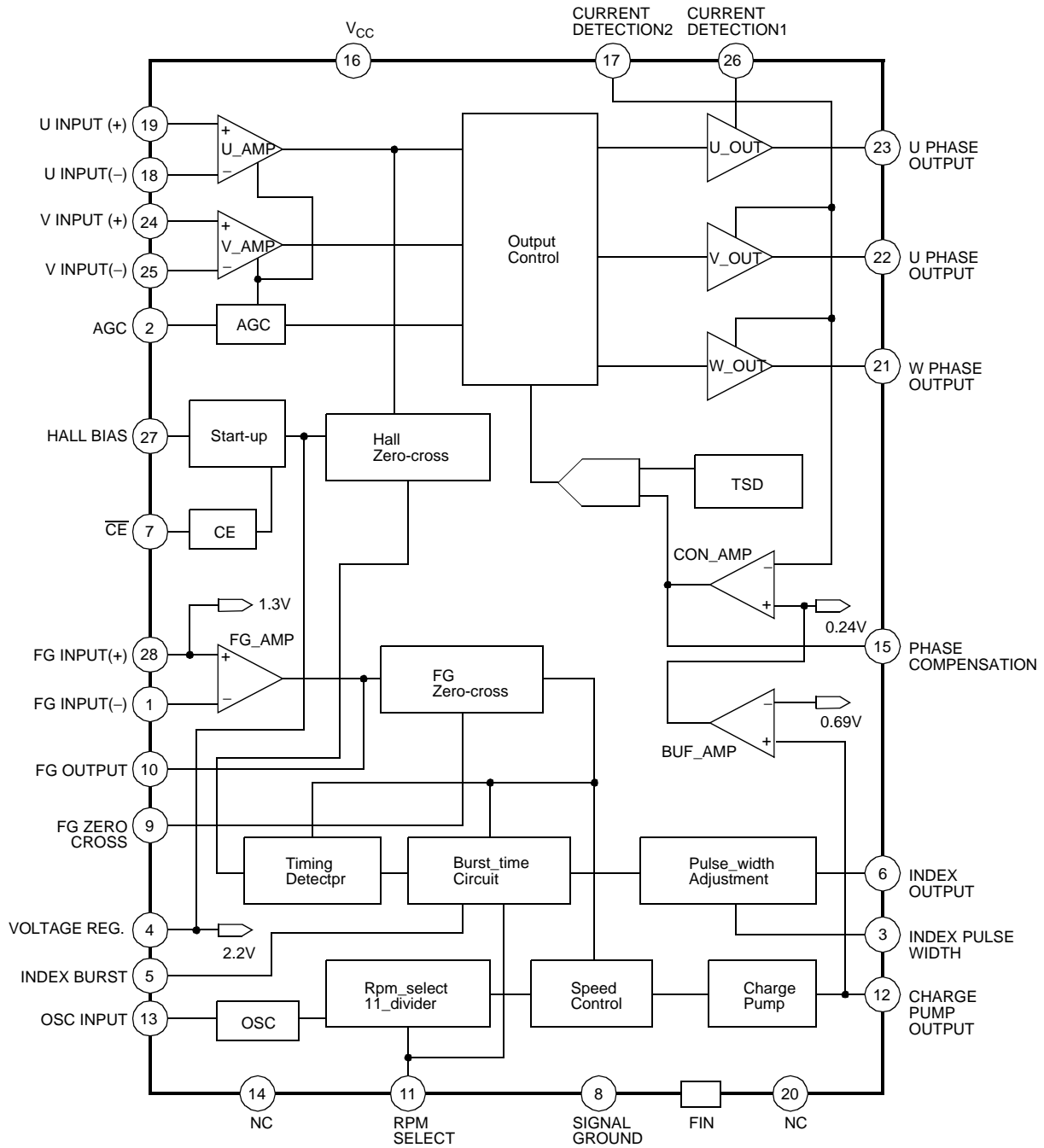

PIN CONFIGURATION

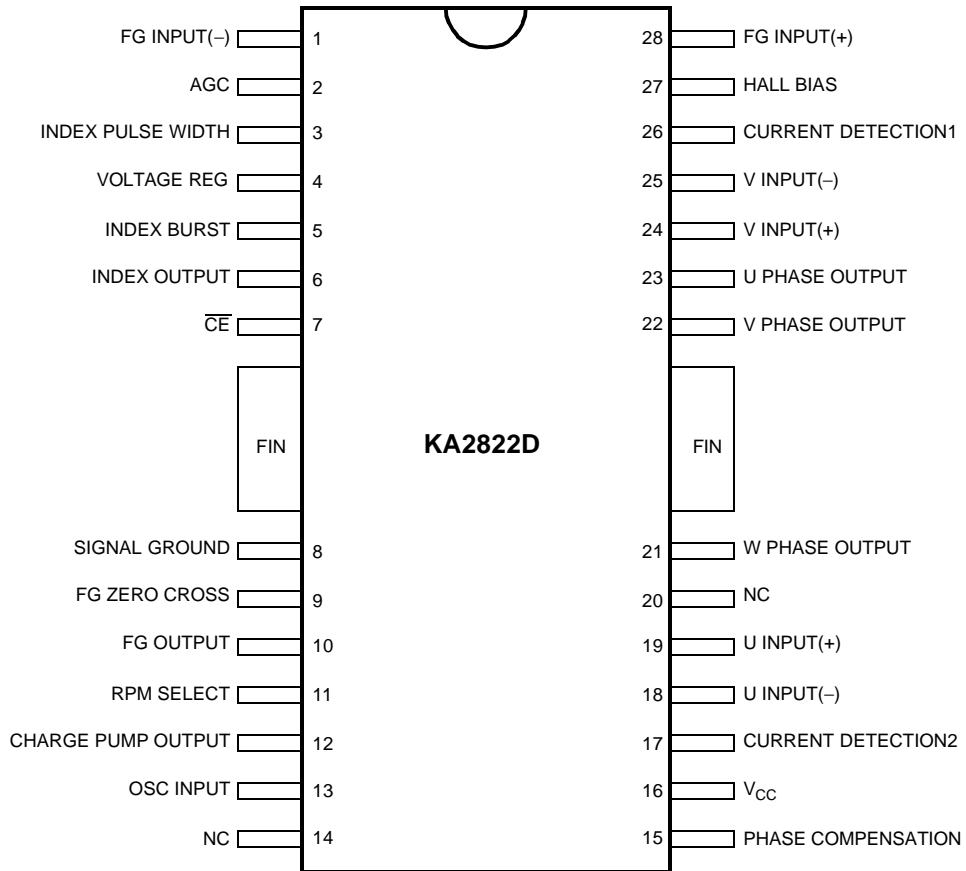

## PIN DESCRIPTION

Pin No.	Symbol	I/O	Description
1	FG_INPUT	I	Negative input pin FG signal amp.
2	AGC	I	Automatic gain control input pin
3	INDEX PULSE WIDTH	O	Index pulse width detection (1.1V) pin
4	VOLTAGE REGULATOR	O	Voltage (2.2V) generator output pin
5	INDEX BURST	O	Index pulse width detection (1.4V) pin
6	INDEX OUTPUT	O	Index pulse output pin
7	CE	I	Chip enable (Active low)
8	SIGNAL GROUND	–	Signal ground
9	FG ZERO CROSS	O	FG signal zero cross detection pin
10	FG OUTPUT	O	FG signal output pin
11	RPM SELECT	I	RPM selection pin (L: 300, H: 360rpm)
12	CHARGE PUMP OUTPUT	O	Charge pump output pin
13	OSC INPUT	I	1MHz oscillation input pin
14	NC	–	No connection
15	PHASE COMPENSATION	I	Phase compensation cap. connection pin
16	V <sub>CC</sub>	–	5V power supply pin
17	CURRENT DETECTION2	I	Over current detection pin
18	U INPUT (–)	I	Negative input pin of U phase amp
19	U INPUT (+)	I	Positive input pin of U phase amp
20	NC	–	No connection
21	W PHASE OUTPUT	O	W phase output pin
22	V PHASE OUTPUT	O	V phase output pin
23	U PHASE OUTPUT	O	U phase output pin
24	U INPUT (+)	I	Positive input pin of V phase amp
25	V INPUT (–)	I	Negative input pin of V phase amp
26	CURRENT DETECTION1	I	Over current detection pin
27	HALL BIAS	I	Hall sensor bias input pin
28	FG INPUT (+)	I	Positive input pin of FG signal amp
FIN	POWER GROUND	–	Power ground

EQUIVALENT CIRCUITS

<p>U_amp, V_amp input</p>	<p>U, V, W drive output and current detection 1, 2</p>
<p>FG input and FG output</p>	<p>OSC input</p>
<p>CE input</p>	<p>Hall bias input and voltage regulator output</p>

EQUIVALENT CIRCUITS (Continued)

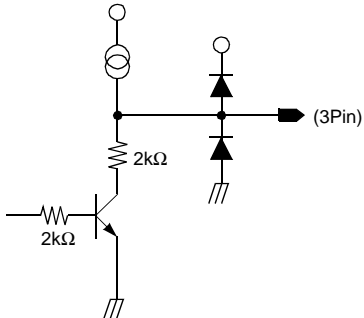
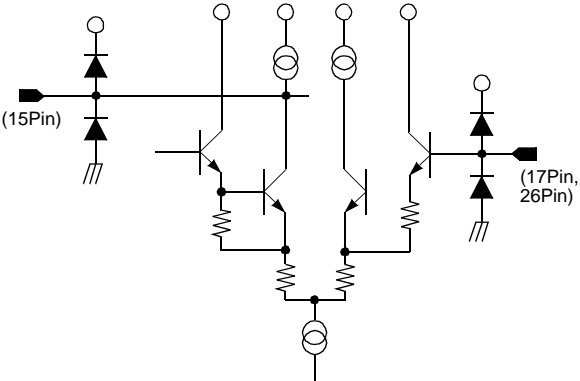
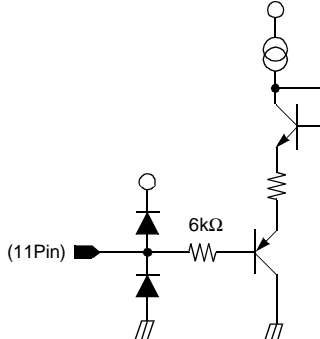
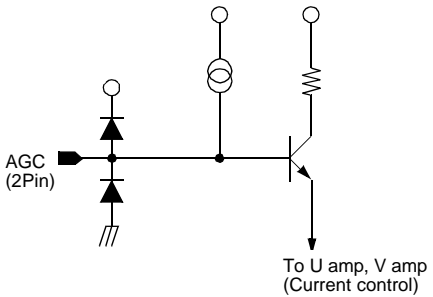
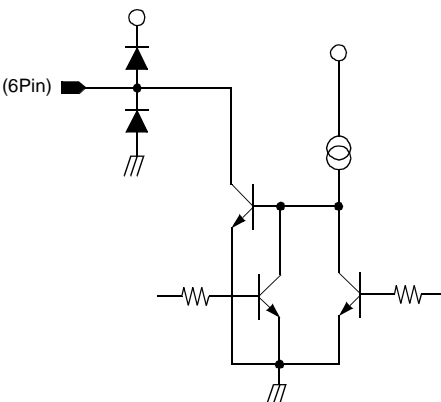
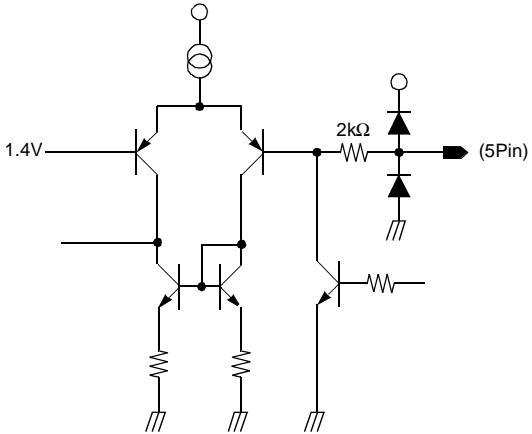
<p style="text-align: center;">Index pulse width detection output</p> 	<p style="text-align: center;">Phase compensation and current detection 1, 2</p> 
<p style="text-align: center;">RPM select input</p> 	<p style="text-align: center;">AGC input</p> 
<p style="text-align: center;">Index output</p> 	<p style="text-align: center;">Index burst output</p> 

EQUIVALENT CIRCUITS (Continued)

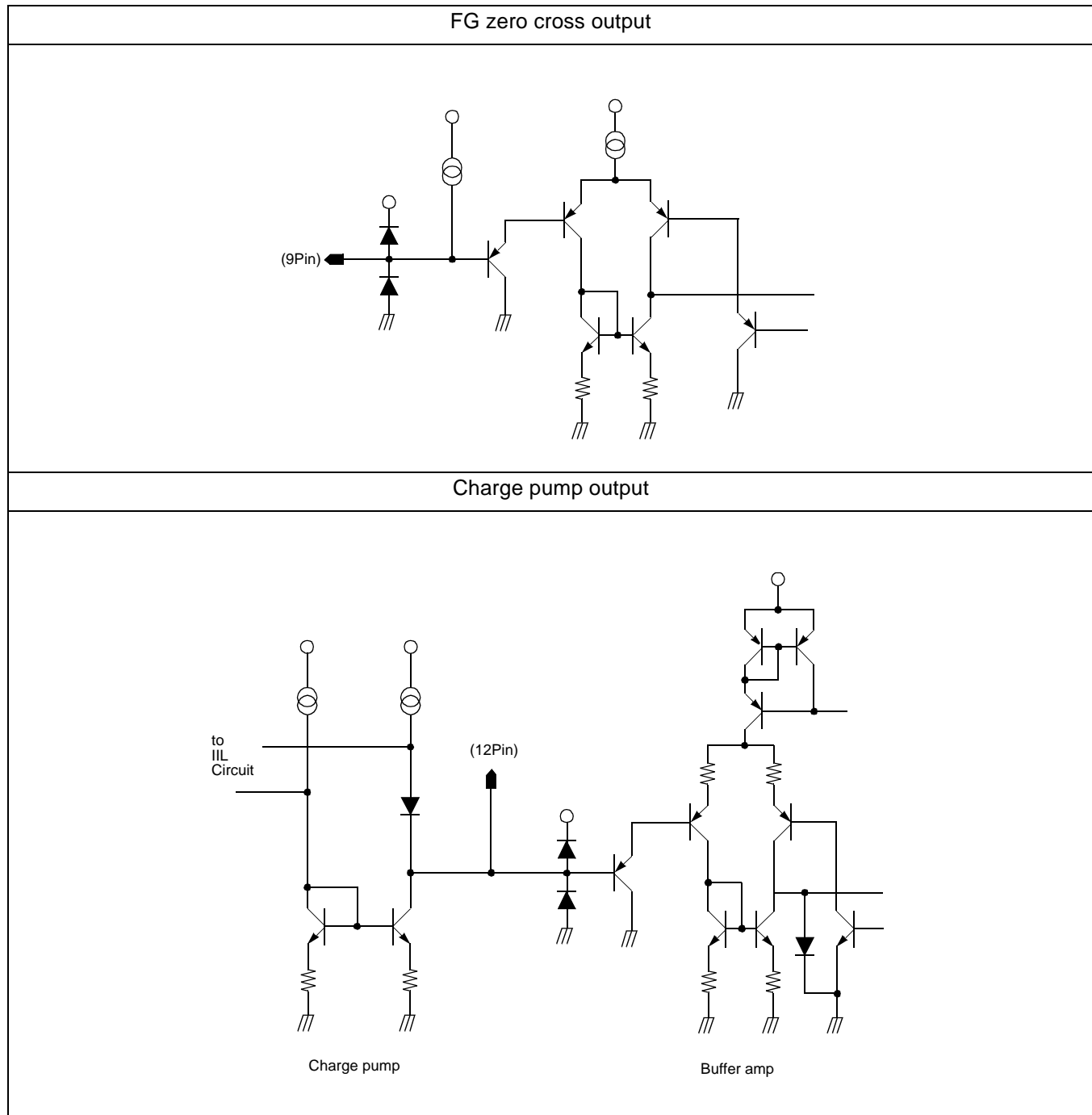

## ABSOLUTE MAXIMUM RATING

Characteristics	Symbol	Value	Unit
Maximum power supply voltage	$V_{CCMAX}$	7.0	V
Maximum input voltage	$V_{INMAX}$	0 ~ $V_{CC}$	V
Maximum output current	$I_{OMAX}$	1	A
Normal output current	$I_O$	0.7	A
Power dissipation	$P_D$	1.5	W
Operating temperature	$T_A$	0 ~ 75	°C
Junction temperature	$T_J$	150	°C
Storage temperature	$T_{STG}$	-55 ~ +125	°C

## POWER DISSIPATION CURVE

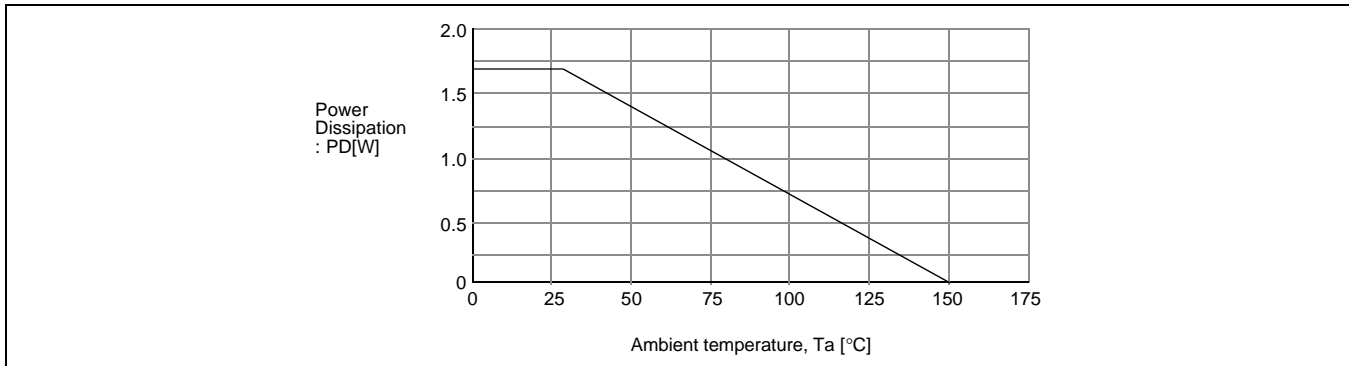

Power dissipation decreases in the rate of 13.5mW / °C when mounted on 50mm × 50mm × 1mm PCB (Phenolic resin material) and used above  $T_a=25^\circ\text{C}$ .

## RECOMMENDED OPERATING CONDITIONS

Characteristics	Symbol	Min.	Typ.	Max.	Unit
Supply voltage	$V_{CC1}, V_{CC2}$	10.8	12.0	13.2	V
Supply voltage in logic part	$V_{CC3}$	4.5	5.0	5.5	V
Ambient operating temperature range	$T_a$	0	-	+70	°C

## TEMPERATURE CHARACTERISTIC

Characteristics	Symbol	Min.	Typ.	Max.	Unit
Thermal shutdown temperature <sup>(note)</sup>	TSD	125	150	-	°C

**NOTE:** Reference value

## ELECTRICAL CHARACTERISTICS

(Ta=25°C, V<sub>CC</sub>=5V)

Characteristic	Symbol	Test conditions	Min.	Typ.	Max.	Unit
<b>SUPPLY CURRENT</b>						
Supply current 1	I <sub>CCO</sub>	V <sub>CC</sub> =6.5V CE=H, RPM=L	–	1.0	2.0	mA
Supply current 2	I <sub>CC</sub>	V <sub>CC</sub> =6.5V, CE=L	–	15	23	mA
<b>CHIP ENABLE</b>						
Input current	I <sub>CE</sub>	CE=0~5V	–	5	10	μA
Input low voltage	I <sub>CE1</sub>	–	–	–	1.0	V
Input high voltage	I <sub>CEH1</sub>	–	3.5	–	–	V
<b>RPM SELECT</b>						
Input current	I <sub>RPM</sub>	CE=0~5V	–	5	10	μA
Input low voltage	V <sub>RPM1</sub>	–	–	–	1.0	V
Input high voltage	V <sub>RPMH</sub>	–	3.5	–	–	V
<b>HALL AMP</b>						
Input resistance <sup>note</sup>	R <sub>I<sub>N</sub></sub>	–	1	10	–	–
Common mode input voltage range <sup>note</sup>	V <sub>COM</sub>	–	2.0	–	V <sub>CC</sub>	V
Differential input voltage range <sup>note</sup>	V <sub>DIF</sub>	–	70	–	210	mV <sub>P-P</sub>
<b>START-UP</b>						
Hall bias voltage 1	V <sub>HB1</sub>	I <sub>H</sub> =4mA, CE=L	2.3	2.5	2.7	V
Hall bias voltage 2	V <sub>HB2</sub>	I <sub>H</sub> =10mA, CE=L	2.7	2.9	3.1	V
Reference voltage	V <sub>ref</sub>	I <sub>O</sub> =1mA, CE=L	1.7	2.2	2.7	V
Bias off current	I <sub>H<sub>OFF</sub></sub>	V <sub>H</sub> =7V, CE=H	–	5	10	μA
<b>OUTPUT AMP</b>						
Leakage current	I <sub>CER</sub>	–	–	0.5	1	mA
Saturation voltage 1	V <sub>sat1</sub>	I <sub>O</sub> =0.35A	–	1.0	1.2	V
Saturation voltage 2	V <sub>sat2</sub>	I <sub>O</sub> =0.7A	–	1.3	1.8	V
<b>BUFFER &amp; CONTROL AMP</b>						
Voltage gain 1 <sup>note</sup>	G <sub>CT1</sub>	–	–	–11	–	dB
Reference voltage 1 <sup>note</sup>	V <sub>ref1</sub>	Current limiter voltage	0.215	0.24	0.265	V
Reference voltage 2 <sup>note</sup>	V <sub>ref2</sub>	Control begin voltage	–	0.69	–	V

NOTE: Reference value

**ELECTRICAL CHARACTERISTICS (Continued)**(Ta=25°C, V<sub>CC</sub>=5V)

Characteristic	Symbol	Test conditions	Min.	Typ.	Max.	Unit
<b>CHARGE PUMP</b>						
Charge current	I <sub>CP-</sub>	RPM=L	-15	-20	-25	μA
Discharge current	I <sub>CP+</sub>	RPM=L	15	20	25	μA
Current ratio <sup>note</sup>	I <sub>R</sub>	I <sub>CP+</sub> / I <sub>CP-</sub>	0.9	1.0	1.1	-
Off current	I <sub>OFF</sub>	V <sub>CP</sub> =0.63V	-	-	50	nA
Clamp voltage <sup>note</sup>	V <sub>CPL</sub>	-	-	1.3	1.5	V
<b>FG AMP</b>						
Output DC voltage <sup>note</sup>	V <sub>FG</sub>	-	1.0	1.3	1.6	V
Voltage gain 2	G <sub>FG</sub>	-	24	34	44	dB
Input voltage range <sup>note</sup>	V <sub>IN</sub>	-	2.0	-	20	mV <sub>P-P</sub>
Noise margin 1 <sup>note</sup>	N <sub>D</sub>	Differential noise	-	-	0.5	mV <sub>P-P</sub>
Noise margin 2 <sup>note</sup>	N <sub>C</sub>	Common mode noise	-	-	0.5	V <sub>P-P</sub>
<b>SPEED CONTROL</b>						
Count range 1 <sup>note</sup>	N1	RPM=L	-	1666.5	-	-
Count range 2 <sup>note</sup>	N2	RPM=H	-	1388.5	-	-
Operating freq.	F <sub>D</sub>	-	-	1.0	1.1	MHz
<b>BURST ADJUSTMENT</b>						
Input current	I <sub>BI</sub>	-	-	1	2	μA
Threshold voltage 1	V <sub>TH1</sub>	RPM=L	1.2	1.45	1.7	V
Threshold voltage 2	V <sub>TH2</sub>	RPM=H	1.05	1.3	1.55	V
<b>PULSE WIDTH ADJUSTMENT</b>						
Ct2 charge current	I <sub>CT2</sub>	-	-19	-25	-36	μA
Threshold voltage 3	V <sub>TH3</sub>	-	0.9	1.1	1.3	V
<b>INDEX OUTPUT</b>						
Output leakage current <sup>note</sup>	I <sub>OH</sub>	-	-	1	2	μA
Output low voltage	V <sub>O1</sub>	I <sub>O</sub> =1mA	-	0.2	0.4	V

**NOTE:** Reference value

## APPLICATION INFORMATION

### 1. CHIP ENABLE

This function turns on or off all blocks by low or high signal.

### 2. U, V AND W PHASE OUTPUT AMP

This part drives the output as making U, V and W current waveform having 120° phase difference with using the current ratio of each amp output after giving the signal occurred by 2 hall sensors to U amp and V amp.

### 3. SPEED CONTROL PART

This function compares the real motor rotation frequency with the 300 or 360Hz pulse divided from 1MHz clock pulse for removing speed error when motor is on and speed error is detected by PLL.

The speed error sent to charge pump part which repeats charge and discharge controls the output current of the output amp to keep a stable rotation.

GRAPHS

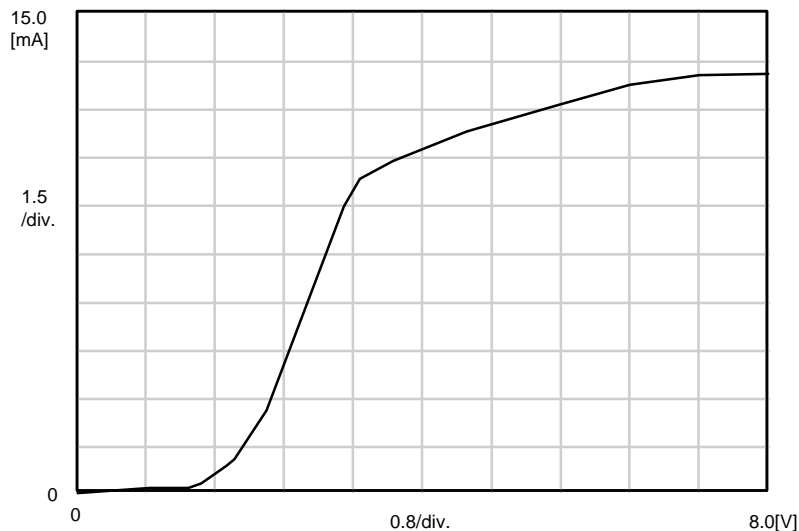

1. V<sub>CC</sub> vs. I<sub>CC</sub>

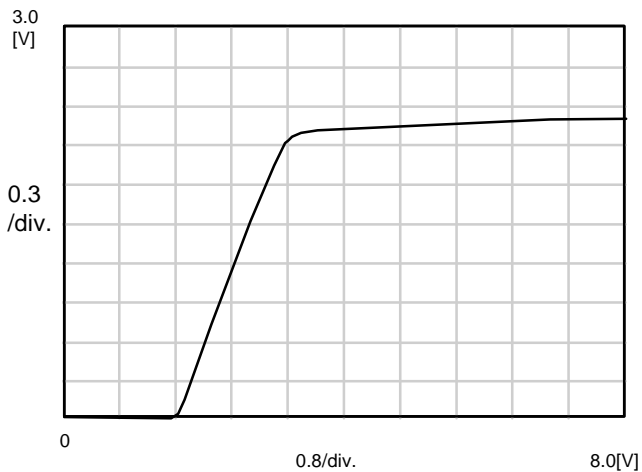

V<sub>CC</sub> vs. V<sub>ref</sub> (Pin4)

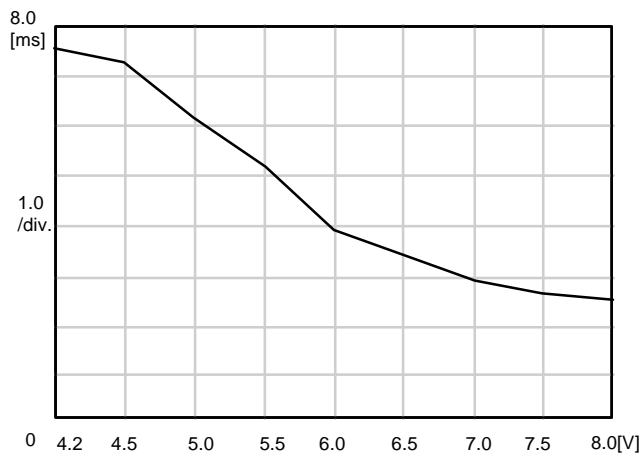

V<sub>CC</sub> vs. Index pulse width





## TRADEMARKS

The following are registered and unregistered trademarks Fairchild Semiconductor owns or is authorized to use and is not intended to be an exhaustive list of all such trademarks.

ACEx™	ISOPLANAR™
CoolFET™	MICROWIRE™
CROSSVOLT™	POP™
E <sup>2</sup> CMOS™	PowerTrench™
FACT™	QS™
FACT Quiet Series™	Quiet Series™
FAST®	SuperSOT™-3
FASTr™	SuperSOT™-6
GTO™	SuperSOT™-8
HiSeC™	TinyLogic™

## DISCLAIMER

FAIRCHILD SEMICONDUCTOR RESERVES THE RIGHT TO MAKE CHANGES WITHOUT FURTHER NOTICE TO ANY PRODUCTS HEREIN TO IMPROVE RELIABILITY, FUNCTION OR DESIGN. FAIRCHILD DOES NOT ASSUME ANY LIABILITY ARISING OUT OF THE APPLICATION OR USE OF ANY PRODUCT OR CIRCUIT DESCRIBED HEREIN; NEITHER DOES IT CONVEY ANY LICENSE UNDER ITS PATENT RIGHTS, NOR THE RIGHTS OF OTHERS.

## LIFE SUPPORT POLICY

FAIRCHILD'S PRODUCTS ARE NOT AUTHORIZED FOR USE AS CRITICAL COMPONENTS IN LIFE SUPPORT DEVICES OR SYSTEMS WITHOUT THE EXPRESS WRITTEN APPROVAL OF FAIRCHILD SEMICONDUCTOR CORPORATION. As used herein:

1. Life support devices or systems are devices or systems which, (a) are intended for surgical implant into the body, or (b) support or sustain life, or (c) whose failure to perform when properly used in accordance with instructions for use provided in the labeling, can be reasonably expected to result in significant injury to the user.
2. A critical component is any component of a life support device or system whose failure to perform can be reasonably expected to cause the failure of the life support device or system, or to affect its safety or effectiveness.

## PRODUCT STATUS DEFINITIONS

### Definition of Terms

Datasheet Identification	Product Status	Definition
Advance Information	Formative or In Design	This datasheet contains the design specifications for product development. Specifications may change in any manner without notice.
Preliminary	First Production	This datasheet contains preliminary data, and supplementary data will be published at a later date. Fairchild Semiconductor reserves the right to make changes at any time without notice in order to improve design.
No Identification Needed	Full Production	This datasheet contains final specifications. Fairchild Semiconductor reserves the right to make changes at any time without notice in order to improve design.
Obsolete	Not In Production	This datasheet contains specifications on a product that has been discontinued by Fairchild semiconductor. The datasheet is printed for reference information only.