

VIDEO IF SYSTEM FOR COLOR TV

The KA2911, KA2916 are silicon monolithic integrated circuits designed for VIF stage in color and B/W television receivers.

KA2911 for Reverse AGC Type.

KA2916 for Forward AGC Type.

FUNCTIONS

- Three controlled IF amplifier stages
- Video demodulator controlled by picture carrier
- Black noise and white noise inverter
- Peak AGC
- DC amplifier for RF AGC out
- Quadrature detector for AFT
- DC amplifier for AFT

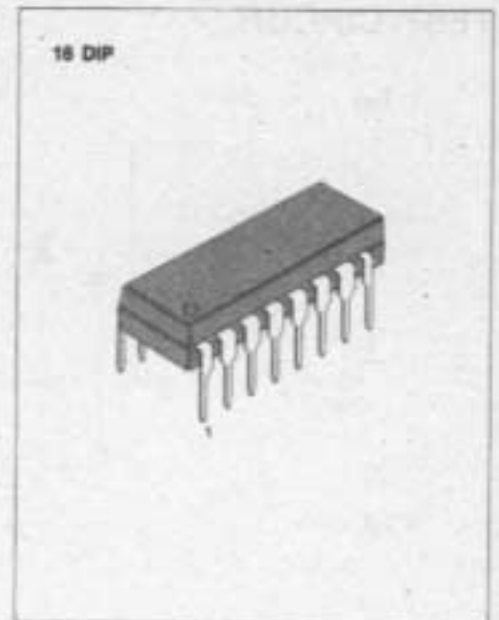

FEATURES

- High gain wide band IF amplifier
- Gain reduction with excellent stability
- Excellent DG/DP characteristics
- Excellent S/N characteristics due to delayed 3 stages AGC action
- Negative video output signal
- Fast AGC action due to noise inverter and peak AGC
- Switch off the video part with VTR SW
- Dual differential AFT output

BLOCK DIAGRAM

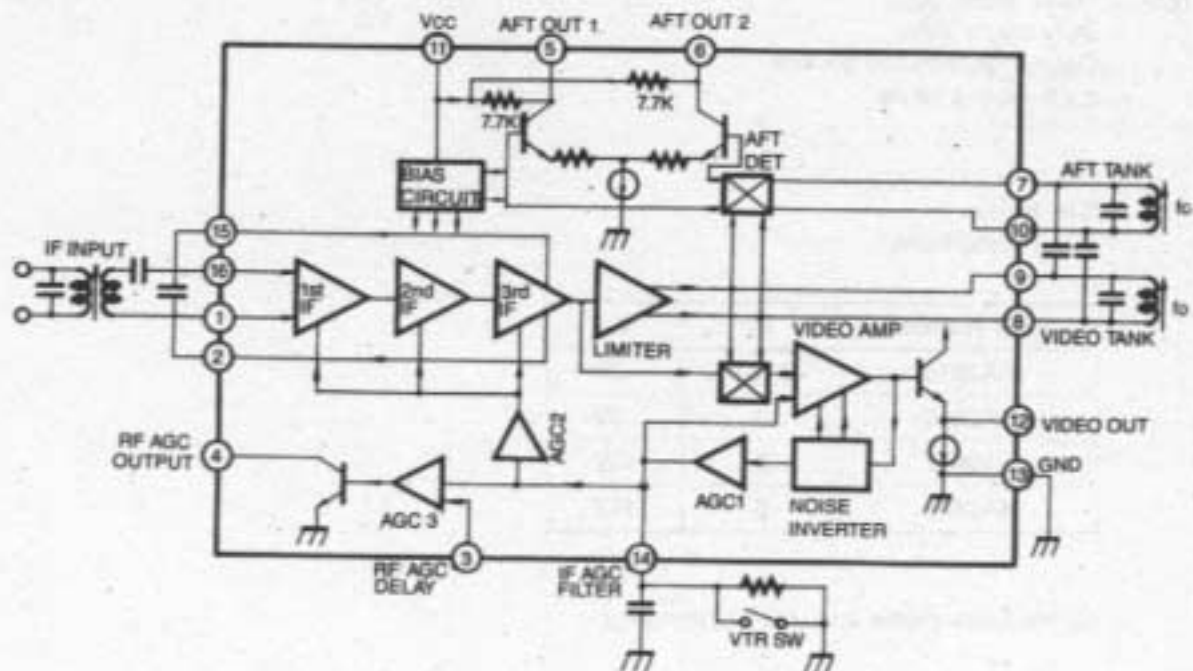

Fig. 2

ABSOLUTE MAXIMUM RATINGS ($T_a = 25^\circ\text{C}$)

Characteristic	Symbol	Value	Unit
Supply Voltage	V_{CC} (Pin 11)	15	V
Open Loop Voltage	V_s (Pin 4)	15	V
Video DC Output Current	I_{O2} (Pin 12)	6	mA
Power Dissipation (Note)	P_d	1.4	W
Operating Temperature	T_{opr}	-20 - +65	$^\circ\text{C}$
Storage Temperature	T_{stg}	-55 - +150	$^\circ\text{C}$

Note: Derated above $T_a = 25^\circ\text{C}$ in the proportion of 11.2mW/ $^\circ\text{C}$

ELECTRICAL CHARACTERISTICS ($T_a = 25^\circ\text{C}$)

Characteristic	Symbol	Test Conditions	Min	Typ	Max	Unit	Test C'CT
Recommended Supply Voltage	V_{CC} (V_{11})		10.8	12.0	13.2	V	
Supply Current	I_{CC} (I_{11})	$V_{CC} = 12\text{V}$	42	51	63	mA	1
Video DC Output Voltage	V_{O2}	$V_{CC} = 12\text{V}$	5.2	5.5	5.8	mA	1
AFT DC Output Voltage	V_{O3}, V_{O6}	$V_{CC} = 12\text{V}$ $SW_1: \text{ON}, SW_2: \text{ON}$	5.3	6.8	8.3	V	1
AFT Output Offset Voltage	$V_{O3} - V_{O6}$	$V_{CC} = 12\text{V}$ $SW_1: \text{ON}, SW_2: \text{ON}$	-1.5	0	1.5	V	1
RF AGC Residual Output Voltage	V_s (sat)	$V_{CC} = 12\text{V}, SW_1: 2, SW_2: 2$ KA2916 $SW_1: 1$ KA2911	—	—	0.5	V	1
RF AGC Leak Current	I_s (Leak)	$V_{CC} = 12\text{V}, SW_1: 1, SW_2: 2$ KA2911 $SW_1: 1$ KA2916	—	—	1	μA	1
Video Sensitivity	V_1 Pin (1-16)	$V_{CC} = 12\text{V}, V_{O2} = 0.8V_{pp}$ $f_c = 45.75\text{MHz AM: } 30\%$	100	200	300	μVrms	2
AGC Range	ΔA (IF)	$V_{CC} = 12\text{V}, f_c = 45.75\text{MHz}$ $V_{14} = 11.5\text{V} \rightarrow 4.0\text{V}$	60	64	—	dB	2
Sync Tip Level Voltage	V_{sync} (V_{12})	$V_{CC} = 12\text{V}$ $f_c = 45.75\text{MHz}$	2.3	2.5	2.7	V	2
Maximum IF Input Voltage	V_{in} (Max)	$V_{CC} = 12\text{V}$ $f_c = 45.75\text{MHz}$	100	120	—	mVrms	2
White Noise Threshold	V_{WTH} (V_{12})	$V_{CC} = 12\text{V}$ $f_c = 45.75\text{MHz}$	5.8	6.2	6.6	V	2
White Noise Clamp Level	V_{WCL} (V_{12})	$V_{CC} = 12\text{V}$ $f_c = 45.75\text{MHz}$	3.7	4.1	4.5	V	2
Black Noise Threshold	V_{BTH} (V_{12})	$V_{CC} = 12\text{V}$ $f_c = 45.75\text{MHz}$	1.4	1.6	1.8	V	2
Black Noise Clamp Level	V_{BCL} (V_{12})	$V_{CC} = 12\text{V}$ $f_c = 45.75\text{MHz}$	2.9	3.3	3.7	V	2
Video Frequency Response	F_{BW}	Input 45.75MHz Sweep generator	4.5	5.5	—	MHz	2

TEST CIRCUIT 3 (DP, DG)

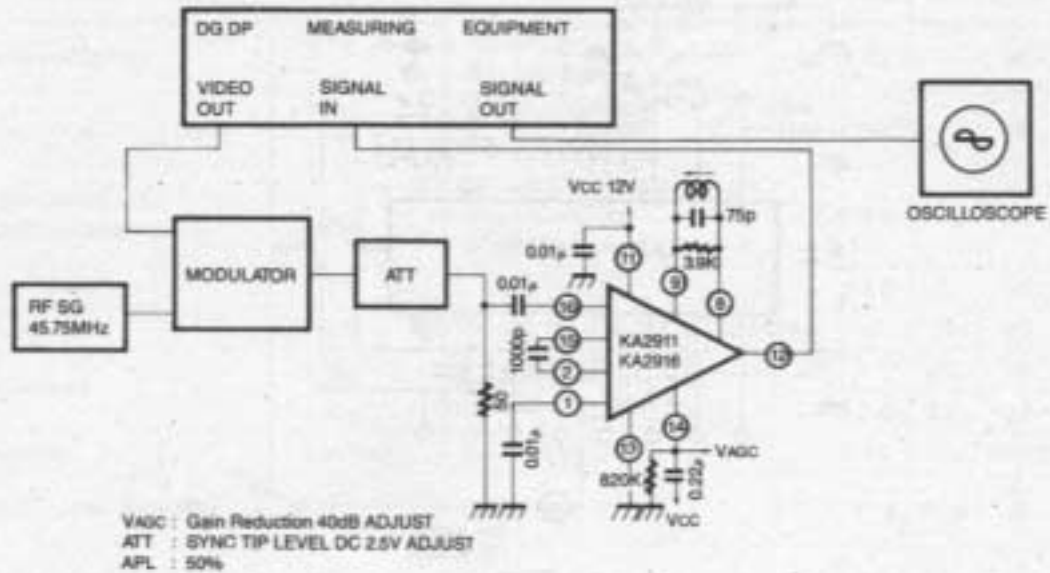

Fig. 4

TEST CIRCUIT 4 (Inter Modulation)

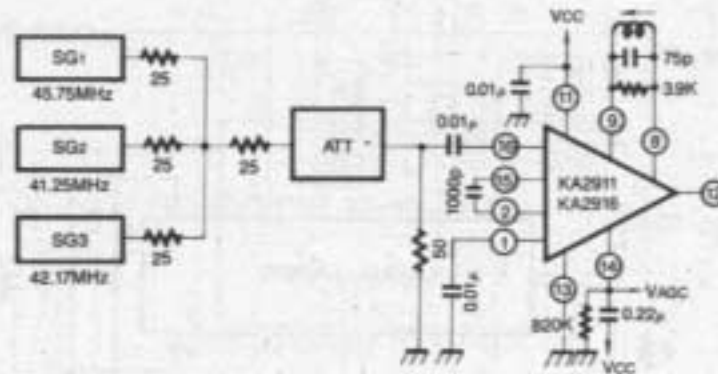

Fig. 5