

## SPINDLE + ACTUATOR DRIVER

The KA3014 is a monolithic integrated circuit suitable for a 4-ch motor driver which drives the tracking actuator, focus actuator, sled motor, loading motor and 3-phase BLDC spindle motor of the MDP/CAR-MD/CAR-NAVIGATION system.

## FEATURES

- Built-in power save circuit
- Built-in current limit circuit
- Built-in thermal shutdown circuit (TSD)
- Built-in hall bias
- Built-in FG signal output circuit
- Built-in rotational direction detecting circuit
- Built-in protection circuit for reverse rotation
- Built-in short brake circuit
- Built-in variable-regulator
- Built-in 4-CH balanced transformerless (BTL) driver
- Built-in BTL mute circuit (CH1/2, CH3 and CH4)
- Corresponds to 3.3V DSP

## TARGET APPLICATION

- MDP
- CAR-MD
- CAR-NAVIGATION

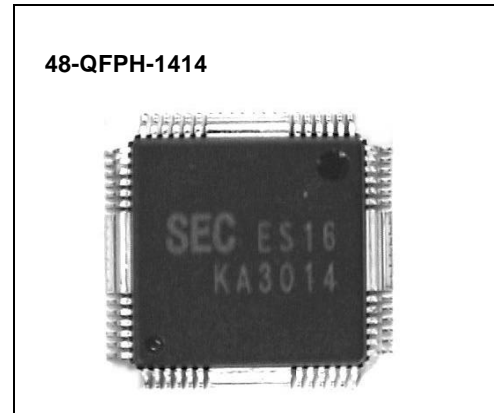

## ORDERING INFORMATION

Device	Package	Operating Temperature
KA3014	48-QFPH-1414	-35°C ~ +85°C

BLOCK DIAGRAM

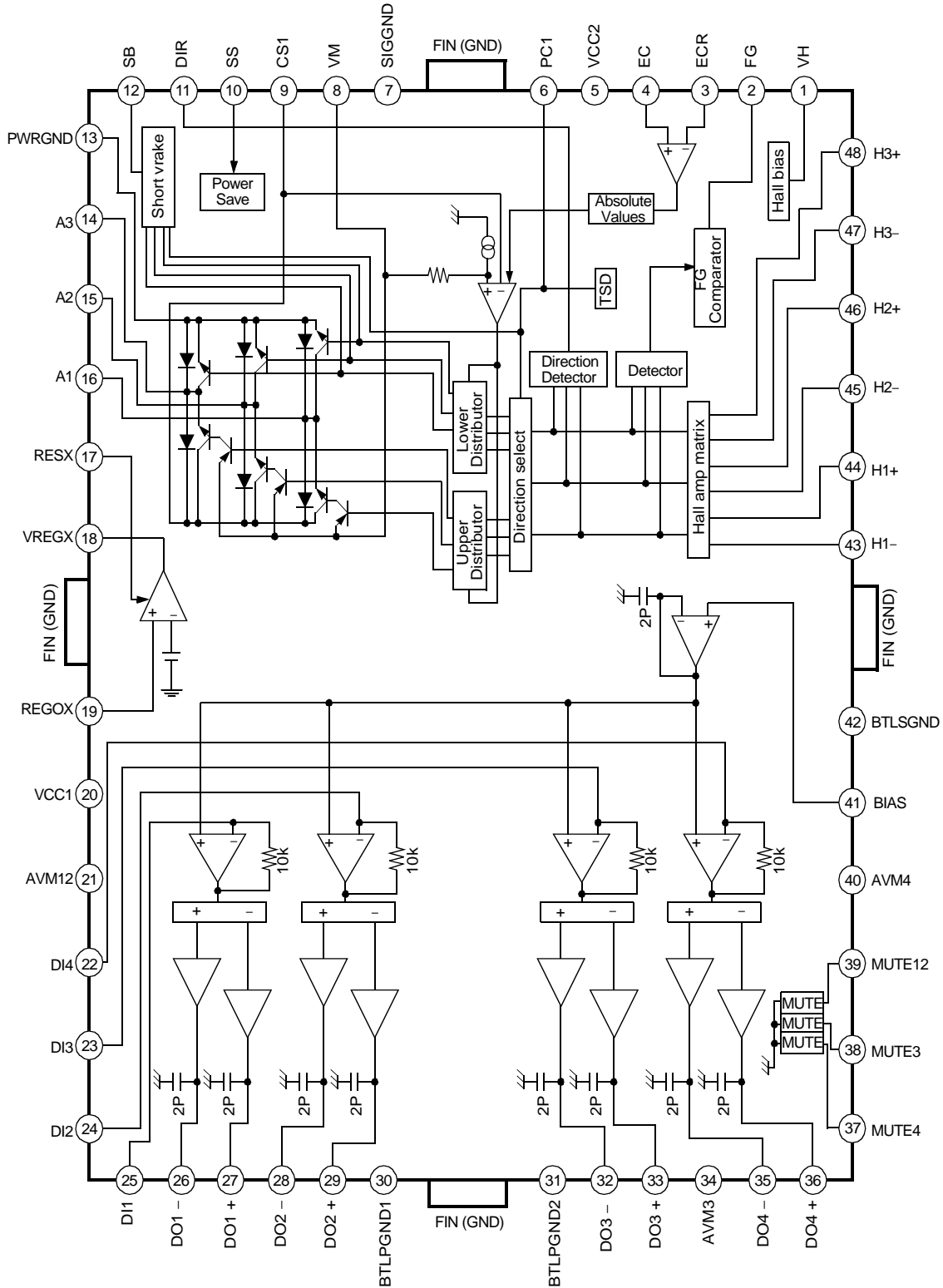

PIN CONFIGURATION

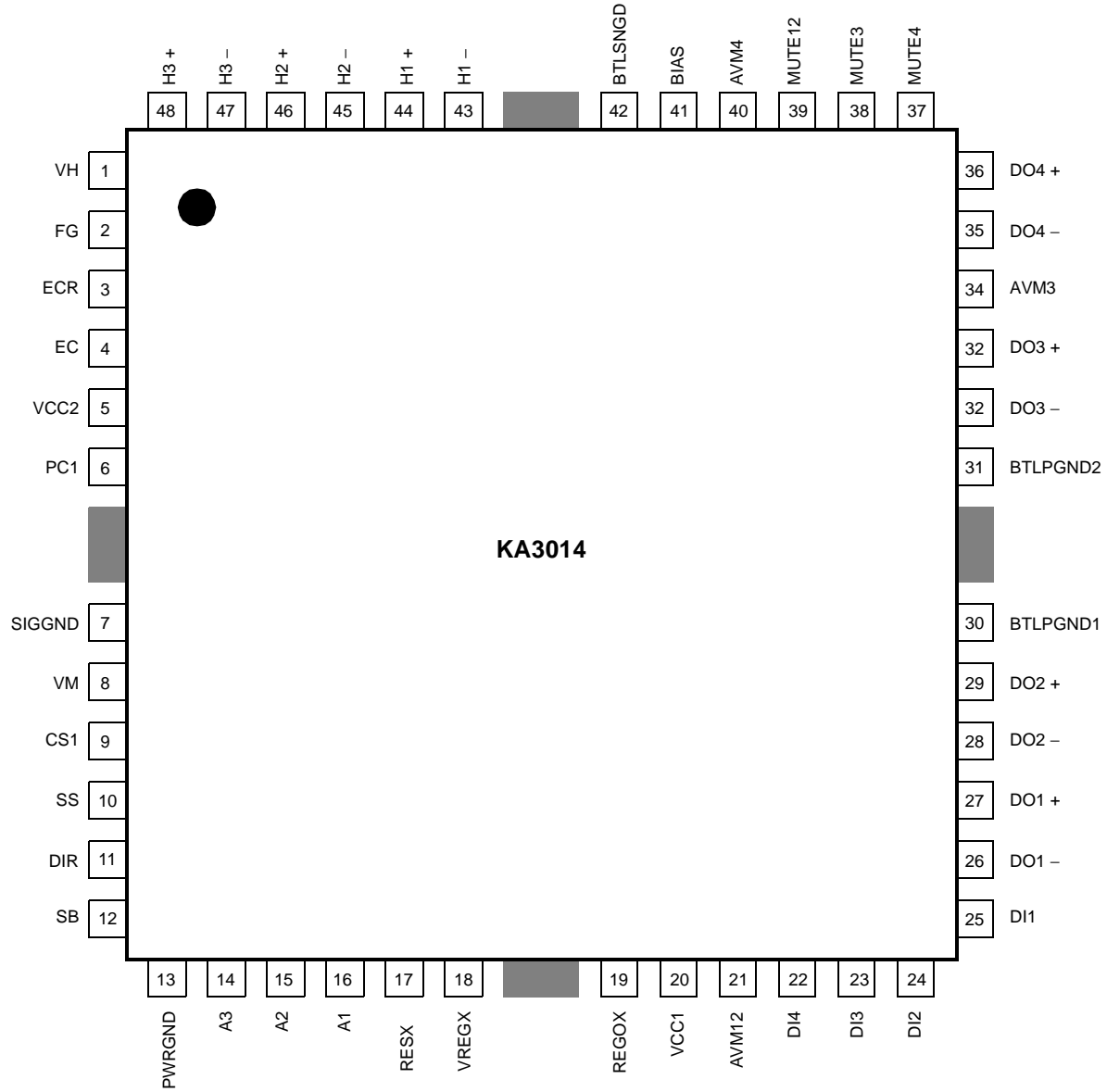

## PIN DESCRIPTION

Pin No.	Symbol	I/O	Description
1	VH	I	Hall bias
2	FG	O	FG signal output
3	ECR	I	Torque control reference
4	EC	I	Torque control signal
5	VCC2	–	Supply voltage
6	PC1	–	Phase compensation capacitor
7	SIGGND	–	Signal ground
8	VM	–	Motor supply voltage
9	CS1	I	Current sensor
10	S/S	I	Start/stop
11	DIR	O	3-phase rotational direction output
12	SB	I	Short brake
13	PWRGND	–	Power ground
14	A3	O	3-phase output 3
15	A2	O	3-phase output 2
16	A1	O	3-phase output 1
17	RESX	I	Variable regulator reset
18	VREGX	O	Variable regulator
19	REGOX	O	Variable regulator output
20	VCC1	–	Supply voltage
21	AVM12	–	BTL CH-1, 2 motor supply voltage
22	DI4	I	BTL drive input 4
23	DI3	I	BTL drive input 3
24	DI2	I	BTL drive input 2
25	DI1	I	BTL drive input 1
26	DO1–	O	BTL drive 1 output (–)
27	DO1+	O	BTL drive 1 output (+)
28	DO2–	O	BTL drive 2 output (–)
29	DO2+	O	BTL drive 2 output (+)
30	BTLPGND1	–	BTL power ground 1
31	BTLPGND2	–	BTL power ground 2

**PIN DESCRIPTION (Continued)**

Pin No.	Symbol	I/O	Description
32	DO3-	O	BTL drive 3 output (-)
33	DO3+	O	BTL drive 3 output (+)
34	AVM3	-	BTL CH3 motor supply voltage
35	DO4-	O	BTL drive 4 output (-)
36	DO4+	O	BTL drive 4 output (+)
37	MUTE4	I	BTL drive mute CH 4
38	MUTE3	I	BTL drive mute CH 3
39	MUTE12	I	BTL drive mute CH 1, 2
40	AVM4	-	BTL CH 4 motor supply voltage
41	BIAS	-	BTL bias voltage
42	BTLSGND	-	BTL drive signal ground
43	H1-	I	Hall1(-) input
44	H1+	I	Hall1(+) input
45	H2-	I	Hall2(-) input
46	H2+	I	Hall2(+) input
47	H3-	I	Hall3(-) input
48	H3+	I	Hall3(+) input

EQUIVALENT CIRCUITS

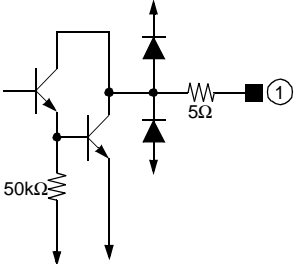
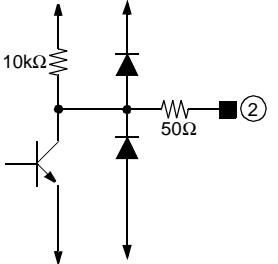
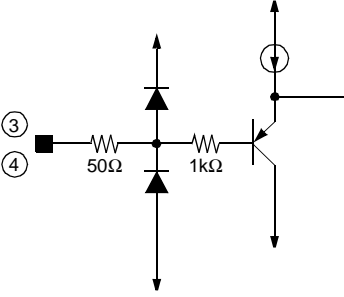
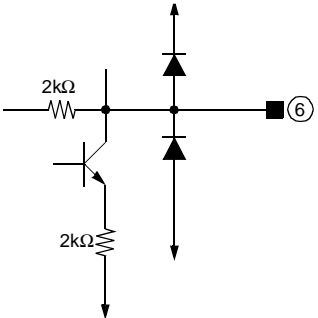
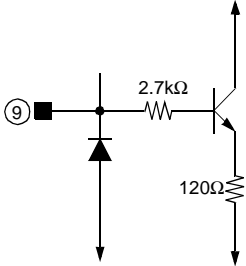
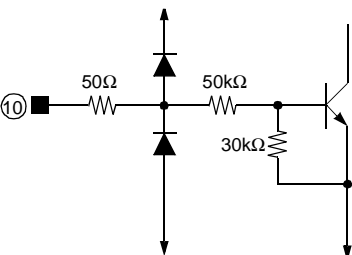
<p style="text-align: center;">Hall bias</p> 	<p style="text-align: center;">FG signal output</p> 
<p style="text-align: center;">Torque control reference &amp; signal</p> 	<p style="text-align: center;">Phase compensation capacitor</p> 
<p style="text-align: center;">Current detector</p> 	<p style="text-align: center;">Start / Stop</p> 

EQUIVALENT CIRCUITS (Continued)

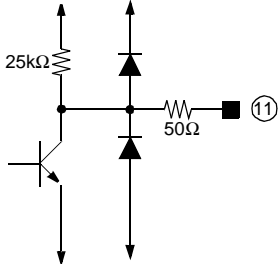
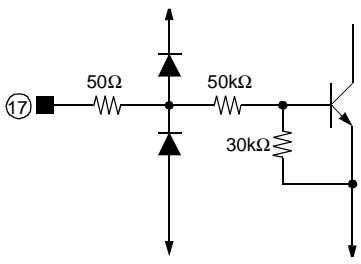
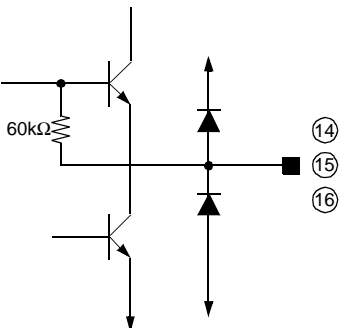
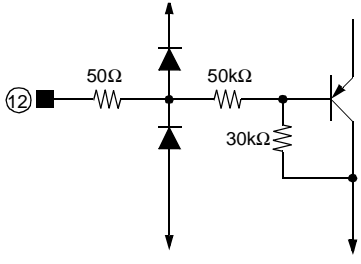
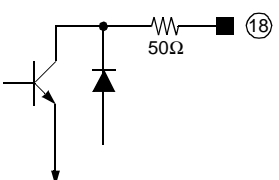
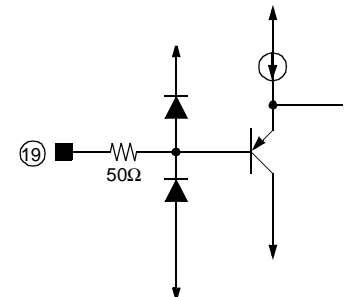
<p>3-phase rotational direction output</p>	<p>Short brake</p>
	
<p>3-phase output</p>	<p>Variable regulator reset</p>
	
<p>Variable regulator</p>	<p>Variable regulator output</p>
	

EQUIVALENT CIRCUITS (Continued)

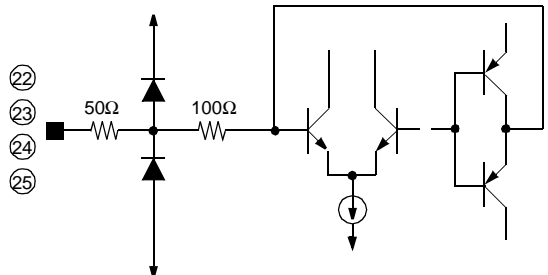
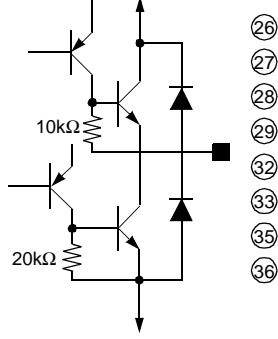
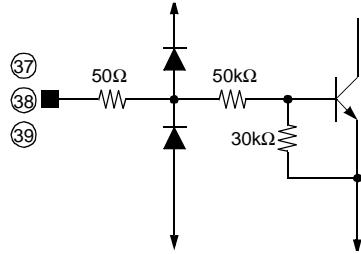
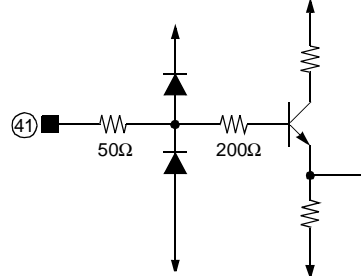
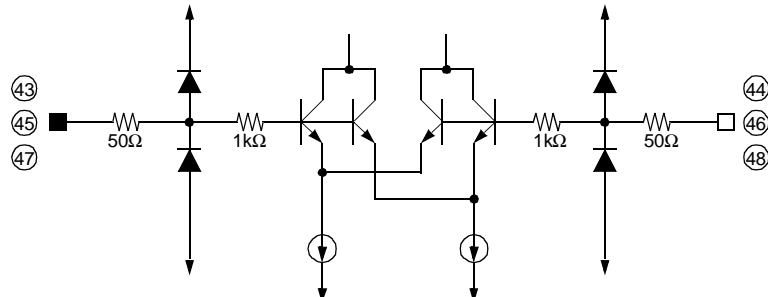
BTL drive input	BTL drive output
	
BTL drive mute	BTL bias voltage
	
Hall input	
	

## ABSOLUTE MAXIMUM RATING

Characteristics	Symbol	Value	Unit
Supply voltage (BTL signal)	$V_{CC1MAX}$	15	V
Supply voltage (Spindle signal)	$V_{CC2MAX}$	7	V
Supply voltage (Spindle motor)	$V_{MMAX}$	15	V
Supply voltage (BTL motor)	$V_{MBTLMAX}$	15	V
Power dissipation	$P_D$	3.0 <sup>note</sup>	W
Operating temperature	$T_{OPR}$	-35 ~ +85	°C
Storage temperature range	$T_{STG}$	-55 ~ +150	°C
Maximum output current (Spindle part)	$I_{OMAXS}$	1.3	A
Maximum output current (BTL part)	$I_{OMAXB}$	1	A

## NOTE:

1. When mounted on 70mm × 70mm × 1.6mm PCB (Phenolic resin material)
2. Power dissipation is reduced 16mW / °C for using above  $T_a=25^{\circ}\text{C}$
3. Do not exceed  $P_d$  and SOA

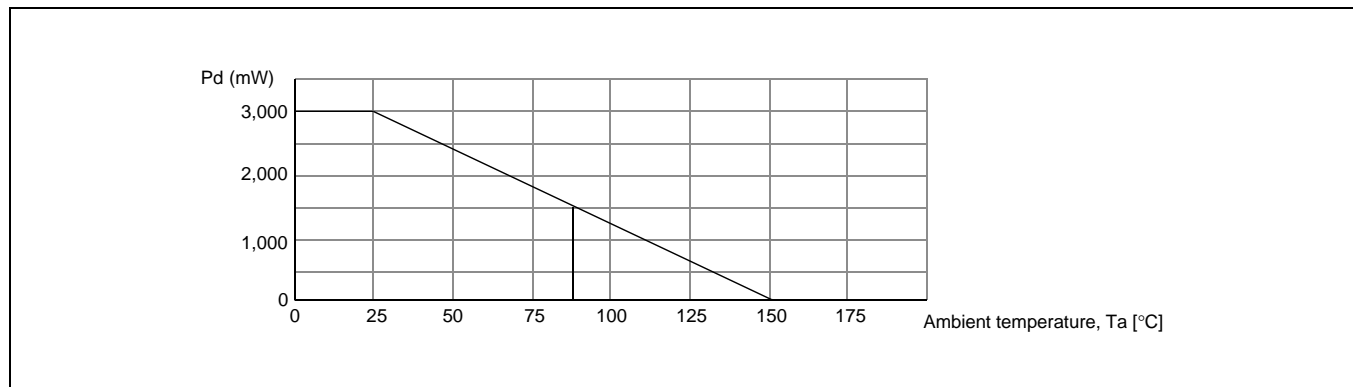

## RECOMMENDED OPERATING CONDITIONS

Characteristics	Symbol	Min.	Typ.	Max.	Unit
Operating supply voltage (BTL signal)	$V_{CC1}$	4.5	–	13.2	V
Operating supply voltage (Spindle signal)	$V_{CC2}$	4.5	–	5.5	V
Operating supply voltage (Spindle motor)	$V_M$	4.5	–	13.2	V
Operating supply voltage (BTL motor)	$V_{MBTL}$	4.5	–	5.5	V

**ELECTRICAL CHARACTERISTICS**(SPINDLE PART,  $T_a=25^\circ\text{C}$ ,  $V_{CC2}=5\text{V}$ ,  $V_M=12\text{V}$ )

Characteristics	Symbol	Test conditions	Min.	Typ.	Max.	Unit
Circuit current 1	$I_{CC1}$	Power save=0V	–	0	0.1	mA
Circuit current 2	$I_{CC2}$	Power save=5V	–	8.0	–	mA
<b>START / STOP</b>						
On voltage range	$V_{PSON}$	L-H circuit on	2.5	–	–	V
Off voltage range	$V_{PSOFF}$	H-L circuit off	–	–	0.5	V
<b>HALL BIAS</b>						
Hall bias voltage	$V_{HB}$	$I_{HB}=20\text{mA}$	–	1.2	1.8	V
<b>HALL AMP</b>						
Hall bias current	$I_{HA}$	–	–	1	5	$\mu\text{A}$
In-phase in voltage range	$V_{HAR}$	–	1.5	–	4.0	V
Minimum in level	$V_{INH}$	–	60	–	–	mVpp
<b>TORQUE CONTROL</b>						
In voltage range	$E_C$	–	0.5	–	3.3	V
Offset voltage (–)	$E_{COFF-}$	$E_{CR}=2.5\text{V}$	–80	–50	–20	mV
Offset voltage (+)	$E_{COFF+}$	$E_{CR}=2.5\text{V}$	20	50	80	mV
In current	$E_{CIN}$	$E_C=E_{CR}=2.5\text{V}$	–5	–1	–	$\mu\text{A}$
In/output gain	$G_{EC}$	$E_{CR}=2.5\text{V}$ , $R_{CS}=0.5\Omega$	0.41	0.51	0.61	A / V
<b>FG</b>						
FG output voltage (H)	$V_{FGH}$	$I_{FG}=-10\mu\text{A}$	3.0	–	$V_{CC}$	V
FG output voltage (L)	$V_{FHL}$	$I_{FG}=10\mu\text{A}$	–	–	0.5	V
Input voltage range	$V_{FGR}$	Hn+, Hn– input D-range	1.5	–	4.0	V
<b>OUTPUT BLOCK</b>						
Saturation voltage (upper TR)	$V_{OH}$	$I_O=-300\text{mA}$	–	0.9	1.6	V
Saturation voltage (lower TR)	$V_{OL}$	$I_O=300\text{mA}$	–	0.2	0.6	V
Torque limit current	$I_{TL}$	$R_{CS}=0.5\Omega$	560	700	840	mA
<b>DIRECTION DETECTOR</b>						
Dir output voltage (H)	$V_{DIRH}$	$I_{FG}=-10\mu\text{A}$	3.0	–	$V_{CC}$	V
Dir output voltage (L)	$V_{DIRL}$	$I_{FG}=10\mu\text{A}$	–	–	0.5	V
<b>SHORT BRAKE</b>						
On voltage range	$V_{SBON}$	–	2.5	–	$V_{CC}$	V
Off voltage range	$V_{SBOFF}$	–	0	–	0.5	V

**ELECTRICAL CHARACTERISTICS (Continued)**(BTL DRIVE PART,  $T_a=25^\circ\text{C}$ ,  $V_{CC1}=12\text{V}$ ,  $V_{MBTL}=12\text{V}$ ,  $R_L=24\Omega$ )

Characteristics	Symbol	Test conditions	Min.	Typ.	Max.	Unit
<b>BTL DRIVE PART (<math>T_a=25^\circ\text{C}</math>, <math>V_{CC1}=12\text{V}</math>, <math>V_{MBTL}=12\text{V}</math>, <math>R_L=24\Omega</math>)</b>						
Quiescent circuit current	$I_{CC}$	–	–	9	12	mA
Output offset voltage	$V_{OO}$	–	–30	–	30	mV
Maximum output Amplitude voltage	$V_{OM}$	–	9.5	10.5	–	V
Voltage gain	$G_{VC}$	$V_{IN}=0.1V_{RMS}$ , 1kHz	10.5	12.0	13.5	dB
Ripple rejection ratio	RR	$V_{IN}=0.1V_{RMS}$ , 120kHz	–	60	–	dB
Slew rate	SR	120Hz, 2Vpp	–	1.0	–	V/ $\mu\text{s}$
Mute off voltage	$V_{MOFF}$	–	–	–	0.5	V
Mute on voltage	$V_{MON}$	–	2.5	–	–	V
<b>VARIABLE-REGULATOR</b>						
Regulator output range	$\Delta V_{REG}$	$I_L=100\text{mA}$	2.0	–	5.25	V
Load regulation	$\Delta V_{R1}$	$I_L=0 \rightarrow 200\text{mA}$	–40	0	10	mV
Line regulation	$\Delta V_{CC}$	$I_L=200\text{mA}$ , $V_{CC}=6\text{V} \rightarrow 9\text{V}$	–20	0	30	mV
Regulator output voltage 1	$V_{REG1}$	$I_L=100\text{mA}$	4.75	5.0	5.25	V
Regulator output voltage 2	$V_{REG2}$	$I_L=100\text{mA}$	3.135	3.3	3.465	V

**CALCULATION OF GAIN & TORQUE LIMIT CURRENT**

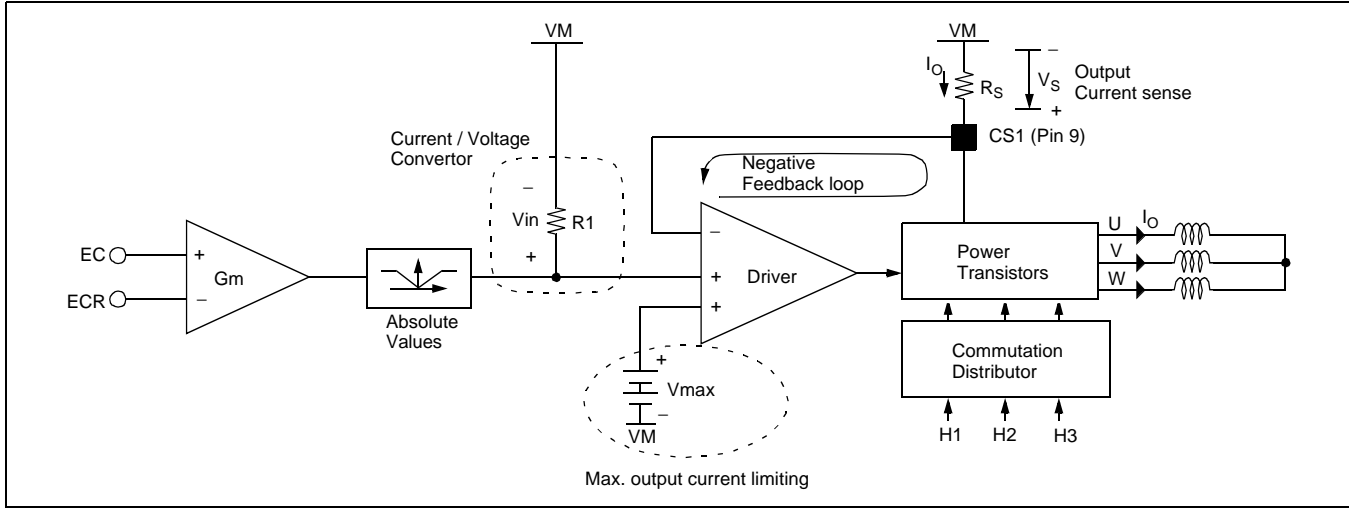

0.255 which is made from GM times R1 is fixed value within IC.

$$Gain = \frac{0.255}{R_S}$$

Vmax (see above block diagram) is setted to 350mV.

$$I_{tl}[mA] = \frac{V_{max}}{R_S} = \frac{350[mV]}{R_S}$$

**APPLICATION INFORMATION**

**1. MUTE FUNCTION**

- Mute control voltage condition  
When using the mute function, the applied control voltage condition is as follows.

Mute on voltage	2.5[V] above	Mute function operation
Mute off voltage	Open or 0.5[V] below	Normal operation

- Separated channel mute function  
These pins are used for individual channel mute operation.
  - When the mute pins (pin 37, 38 and 39) are open or the voltage of the mute pins are below 0.5[V], the mute circuit is stopped and BTL output circuits operate normally.
  - When the mute pins (pin 37, 38 and 39) are above 2.5[V], the mute circuits are activated so that the BTL output circuits will be muted.
  - If the junction temperature rises above 175°C, then the thermal shutdown (TSD) circuit is activated and all the output circuits (4-CH BTL drivers and 3-phase BLDC driver) are muted.

## 2. 4-CH BALANCED TRANSFORMERLESS (BTL) DRIVER

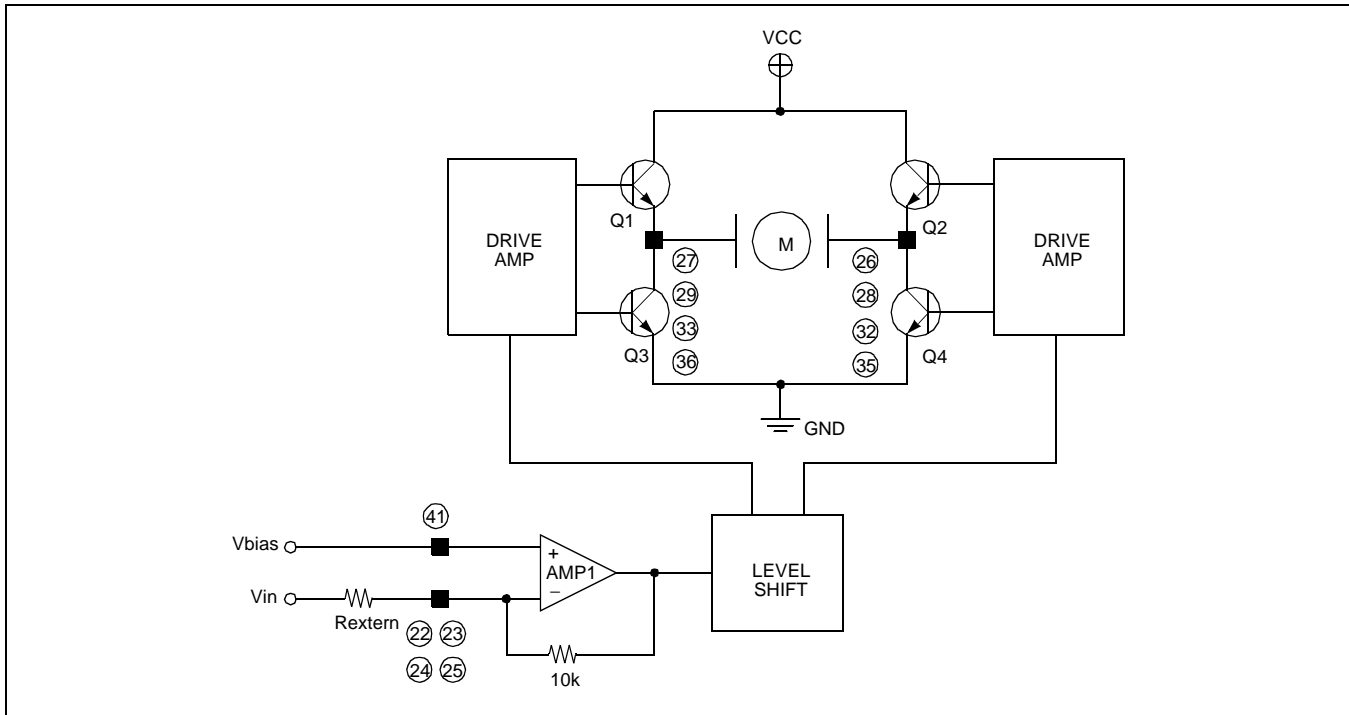

- The voltage,  $V_{bias}$ , is the reference voltage given by the external bias voltage of pin 41.
- The input signals,  $V_{in}$ , through the pins (pin 22, 23, 24 and 25) are amplified  $10k/R_{extern}$  times and then fed to the level shift.
- The level shift produces the current due to the difference between the input signal ( $V_{in}$ ) and the arbitrary reference voltage ( $V_{bias}$ ). The current produced as  $+\Delta I$  and  $-\Delta I$  are fed into the drive buffers.
- The drive buffer operates the power TR of the output stage according to the state of the input signal ( $V_{in}$ ).
- The output stage is the BTL driver, and the motor (or actuator) is rotating in forward direction by operating TR Q1 and TR Q4. On the other hand, if TR Q2 and TR Q3 are operating, the motor (or actuator) is rotating in reverse direction.
- When the input signal  $V_{in}$ , through the pin (pin 22, 23, 24 and 25) is below the  $V_{bias}$ , then the motor (actuator) is in forward direction.
- When the input signal  $V_{in}$ , through the pin (pin 22, 23, 24 and 25) is above the  $V_{bias}$ , then the motor (actuator) is in reverse direction.
- If you want to change the gain, then modify the external resistor's value ( $R_{extern}$ )

3. TORQUE & OUTPUT CURRENT CONTROL

Torque control & output current control

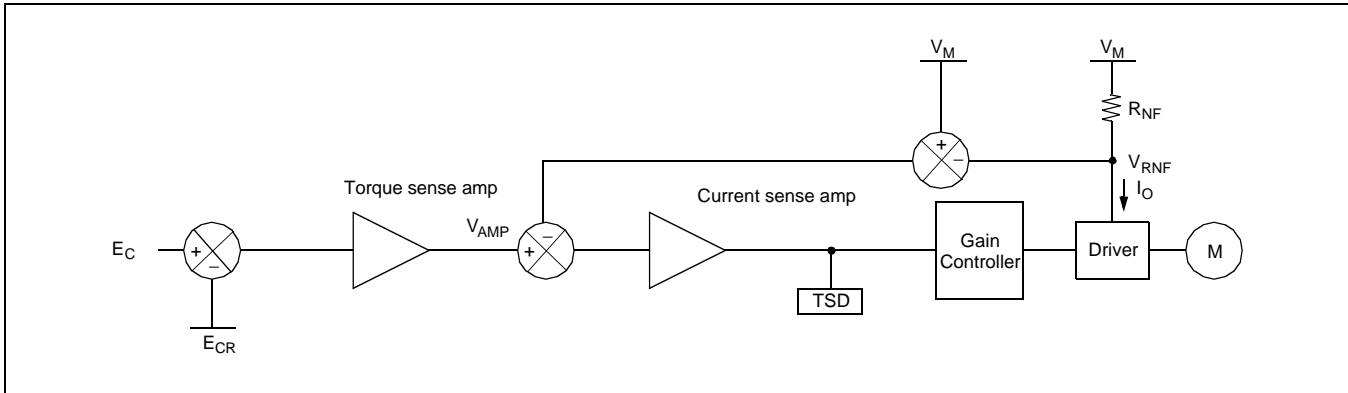

- By amplifying the voltage difference between  $E_C$  and  $E_{CR}$  from the servo IC, the torque sense amp produces the input ( $V_{AMP}$ ) for the current sense amp.
- The current sense amp produces the input for the gain controller to allow the output current ( $I_O$ ) of the driver to be controlled by the input voltage ( $V_{AMP}$ ), where the output current ( $I_O$ ) is detected by the sense resistor ( $R_{NF}$ ) and is converted into  $V_{RNF}$ .
- In the end, the signals of the servo IC control the velocity of the motor by controlling the output current ( $I_O$ ) of the driver.
- When the junction temperature rises up to about  $175^\circ\text{C}$ , then the output drive circuit will be shut down.
- The range of the torque control input voltage is as shown below.

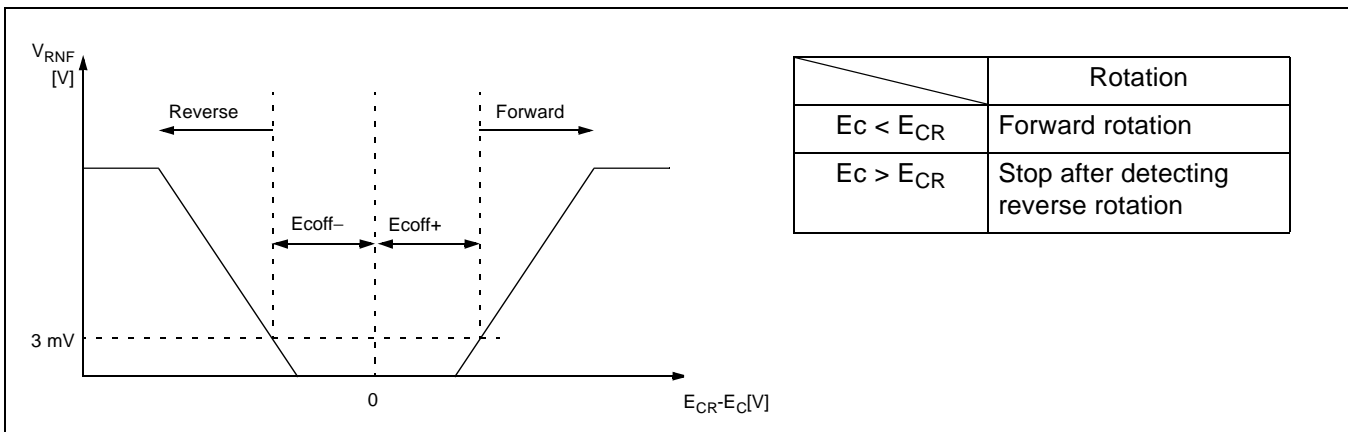

The input range ( $E_C$ ) of the torque sense amp is  $0.5\text{V} \sim 3.3\text{V}$ .

4. POWER SAVE FUNCTION

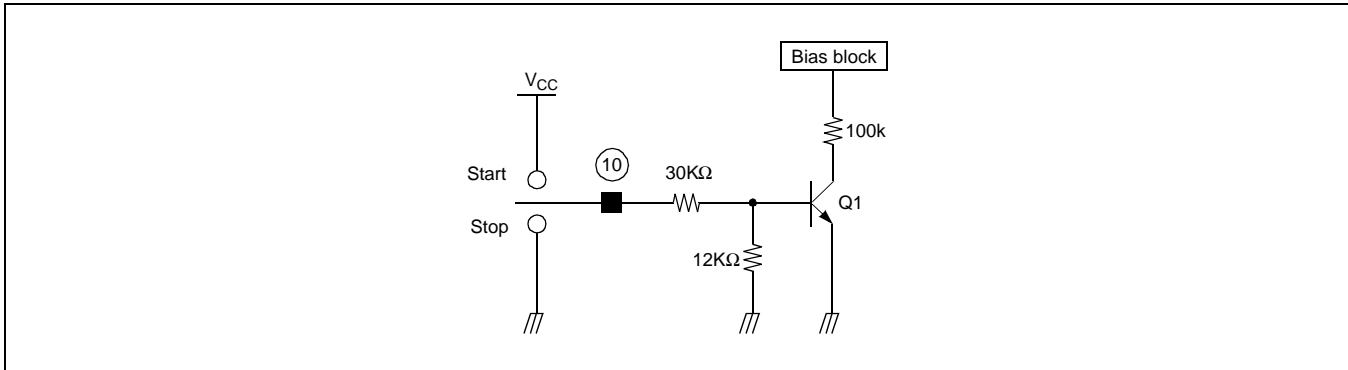

- This function block operates the power saving function.
- The power save circuit is activated by operating TR Q1.
- When the SS (Start / Stop) pin 10 is high ( $V_{CC}$ ), the TR Q1 is turned on so that the bias circuit is enabled. On the other hand, when the SS (Start/Stop) pin 10 is open or low (GND), the TR Q1 is turned off so that the bias circuit is disabled.
- The power save operation controlled by SS (pin 10) input conditions is as follows;

Pin #10	KA3014
High	Start
Opin / Low	Stop

## 5. SHORT BRAKE FUNCTION

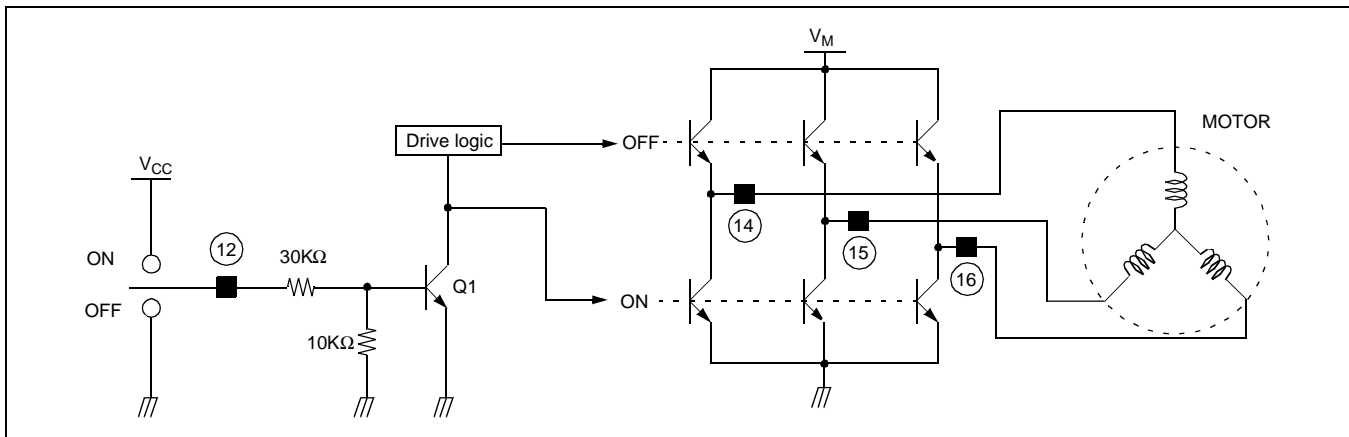

When the pick-up part moves from the inner to the outer spindle of the MD, the brake function of the reverse voltage is commonly employed to rate the rotational velocity of the spindle motor.

However, if the spindle motor rotates rapidly, the brake function of the reverse voltage may produce too much heat at the drive IC.

To remove these shortcomings and to enhance efficiency, the short brake function is added to KA3014. When the short brake function is active, all upper power transistors are turned off and the lower power transistors turned on, so as to reduce the rotational velocity of the motor. The short brake operation controlled by SB (pin 12) inputs conditions shown to the left.

Pin #12	Short brake
High	On
Low	Off

## 6. THERMAL SHUTDOWN (TSD) FUNCTION

When the junction temperature rises up to about 175°C, then the output drive circuit is shut down, when the junction temperature falls off to about 160°C, the output drive circuit will be normally operated.

It has the temperature hysteresis of about 15°C.

7. ROTATIONAL DIRECTION DETECTION FUNCTION

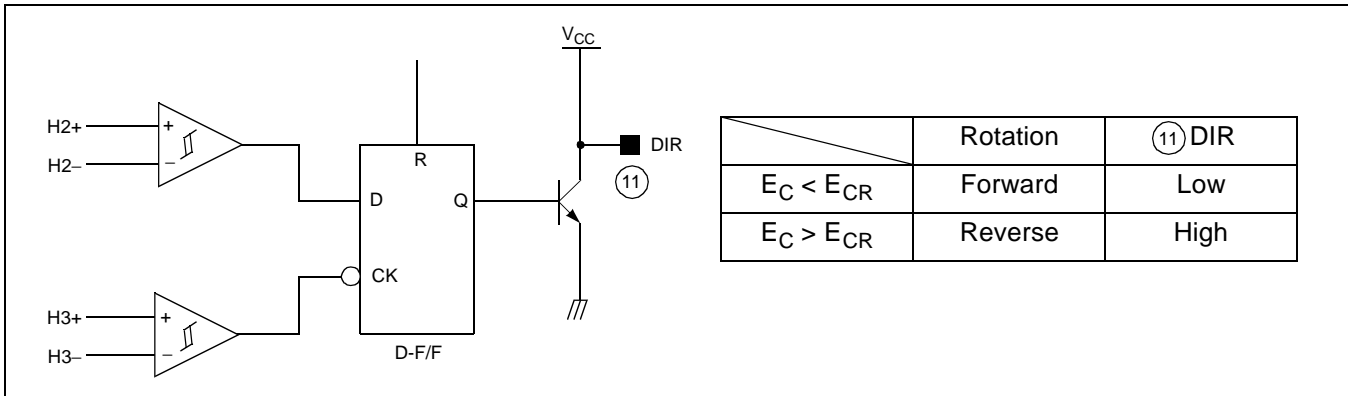

- The forward and reverse rotations of the MD are detected by the circuit, as shown in the above table.
- The rotational direction of the MD can be learned by the output waveforms of the hall sensor and/or the driver. Let the three hall sensors be H1, H2 and H3 respectively. If the hall sensors turn on in the order, H1→H2→H3, of the reverse rotation, the output waveforms of the hall sensors will be as shown below.

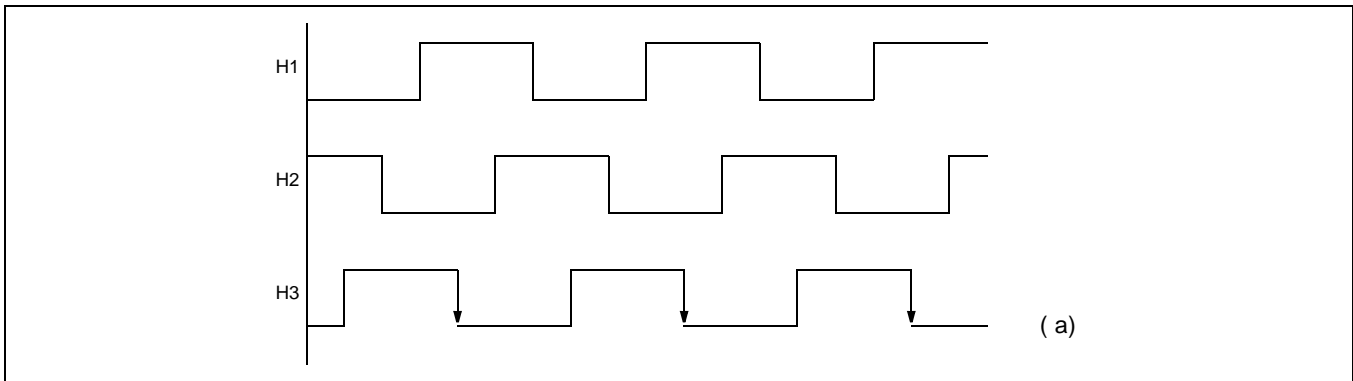

Inversely, if the hall sensors turn on in the order, H3 → H2 → H1, of the forward rotation, the output waveforms of the hall sensors will be as shown next page.

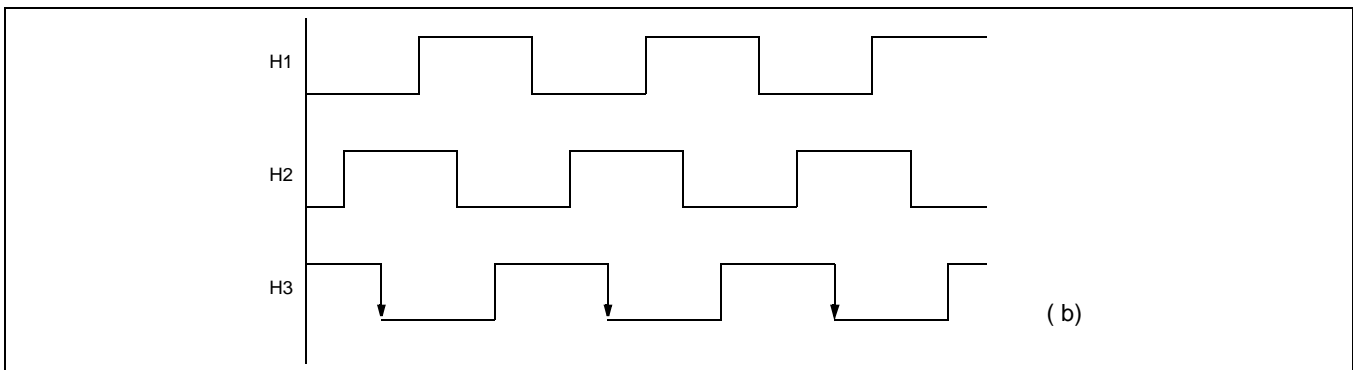

In the cases above, the value of H2 at the falling edges of H3 is low in figure <a>, while High in figure <b>. The rotational direction detector takes advantage of this phenomenon.

8. REVERSE ROTATION PREVENT FUNCTION

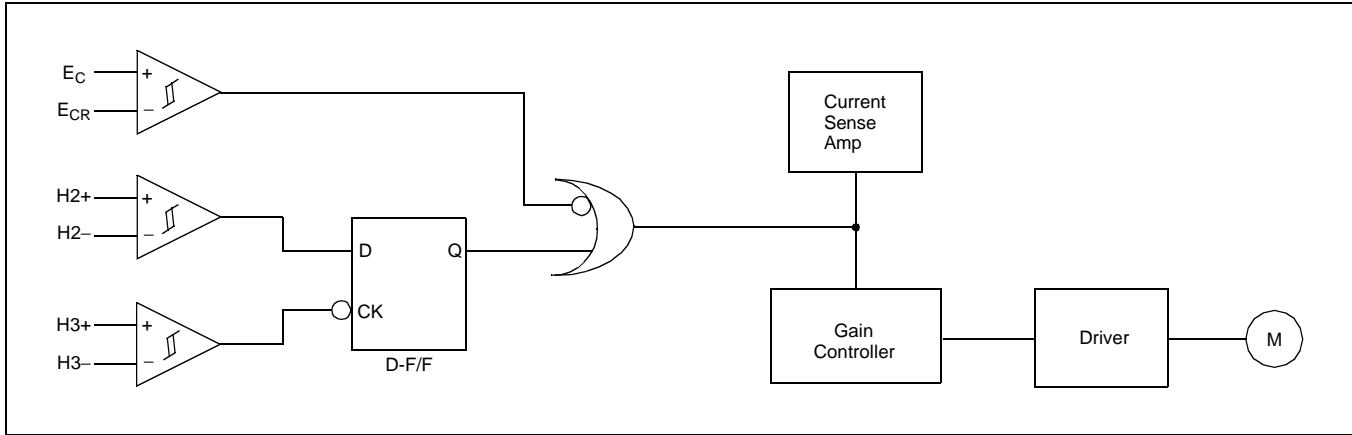

- The forward and reverse rotation of the motor are detected, as shown in the table below, by the circuit shown above. Consequently at reverse rotation, the D-F/F output Q becomes low and cuts off the output current sense amp, resulting in the stoppage of the gain controller function.
- When the MD is rotating in forward direction,  $E_C > E_{CR}$  is sometimes controlled to retard and/or stop the MD. As the controlling time of  $E_C > E_{CR}$  gets longer, MD slows down, stops, and then rotates in the reverse direction. To prevent the MD from rotating in the reverse direction, a reverse rotation resistant function is required. Its operational principles are discussed below.

Rotation	H2	H3	D-F/F	Reverse rotation preventer	
				$E_C < E_{CR}$	$E_C > E_{CR}$
Forward	H	H → L	H	Forward	Brake stop
Reverse	L	H → L	L	–	Brake and stop

9. FG OUTPUT FUNCTION

The FG output, which detects the number of rotations of the MD, is generated by combination zero-crossing the output waveforms of the hall sensors. The FG output circuit is as shown below.

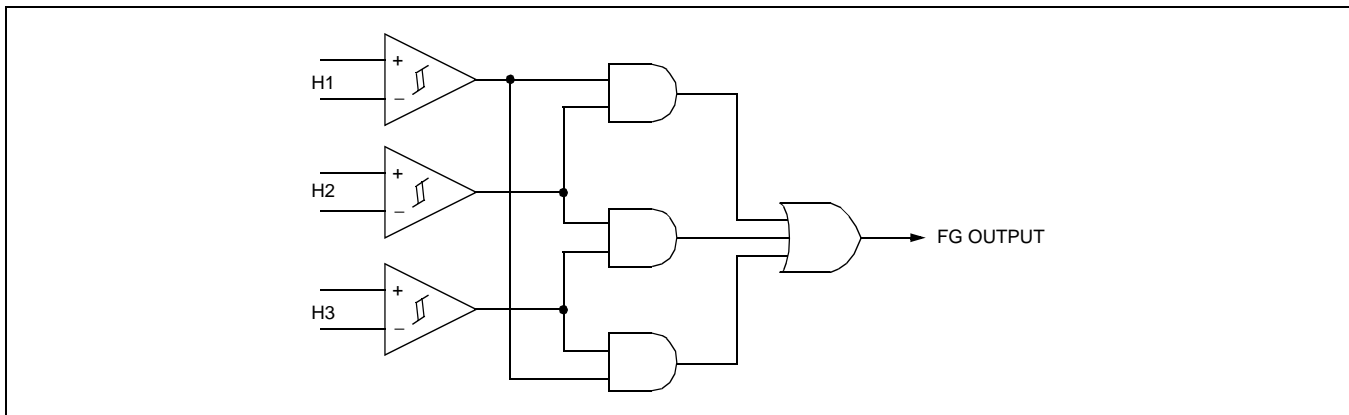

## 10. HALL SENSOR CONNECTION

External hall sensors are used in series or parallel connection as shown below.

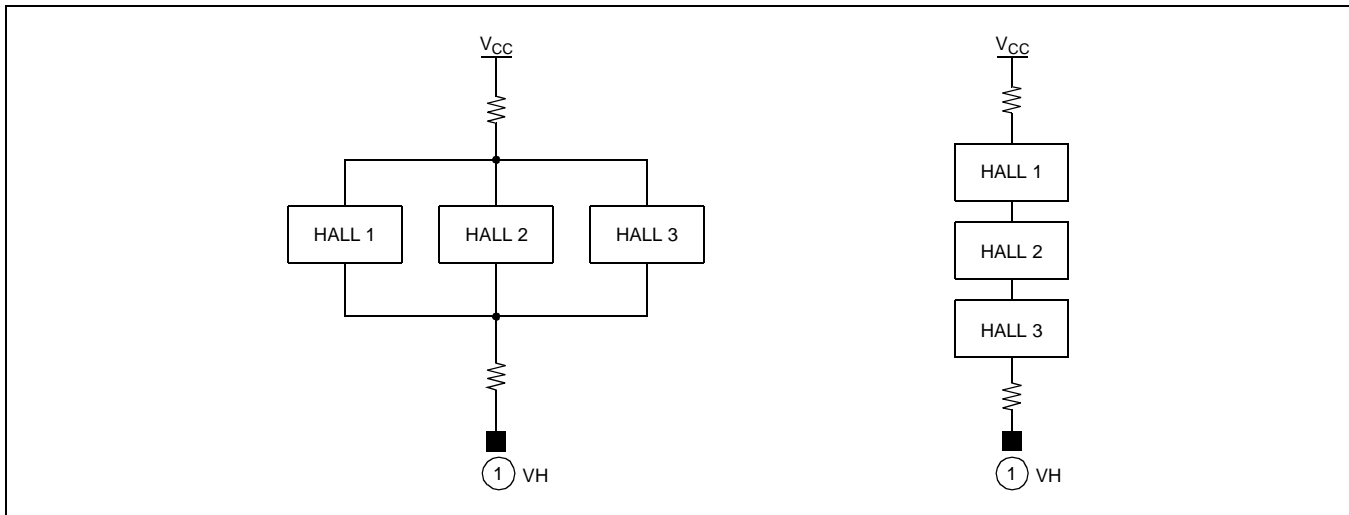

## 11. HALL INPUT OUTPUT TIMING CHART

The 3-phase hall signal is amplified in the hall amplifiers and sent to the matrix section, where the signal is further amplified and combined. After the signal is converted to a current in the amplitude control circuit, the current is supplied to the output driver, which then provides a motor drive current. The phases of the hall input signal, output voltage, and output current are shown below.

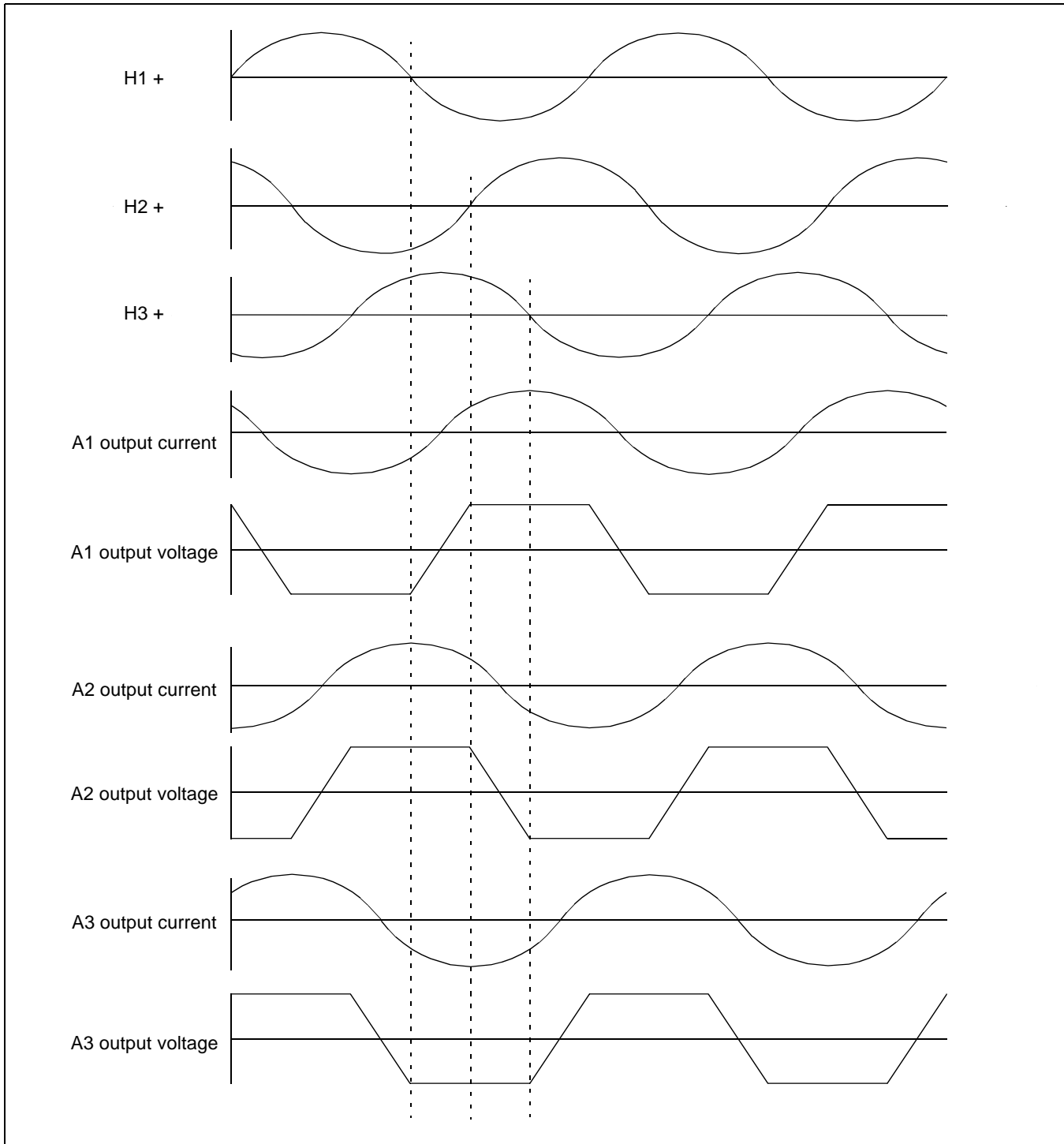

ELECTRICAL CHARACTERISTIC CURVES

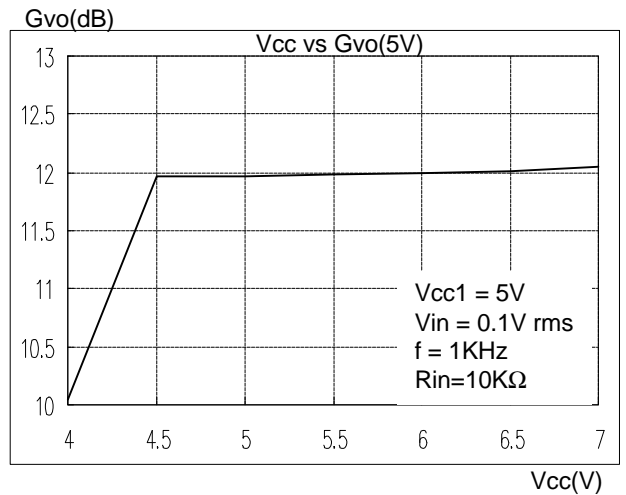
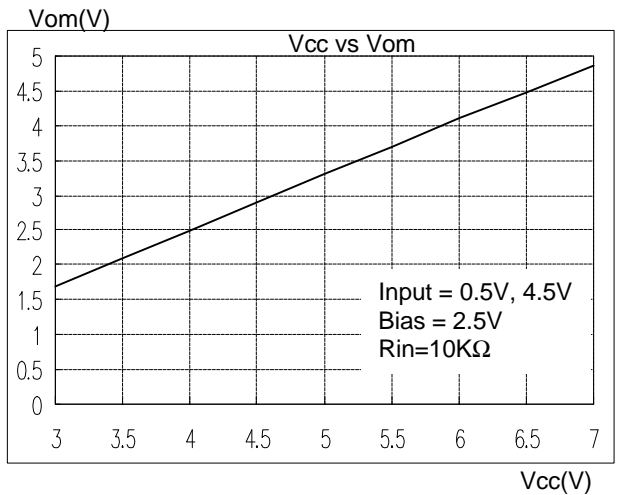
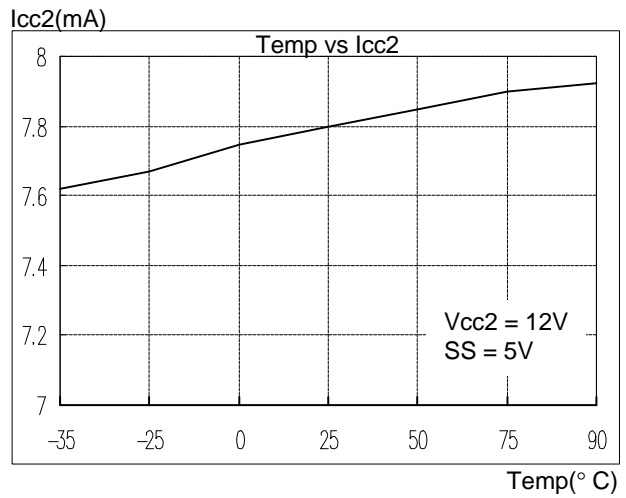
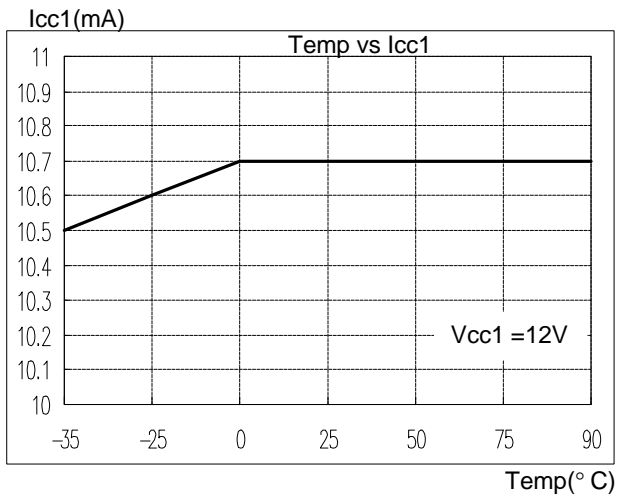
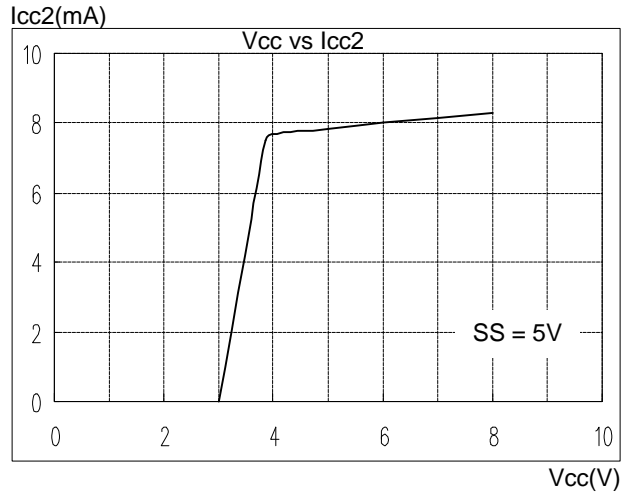
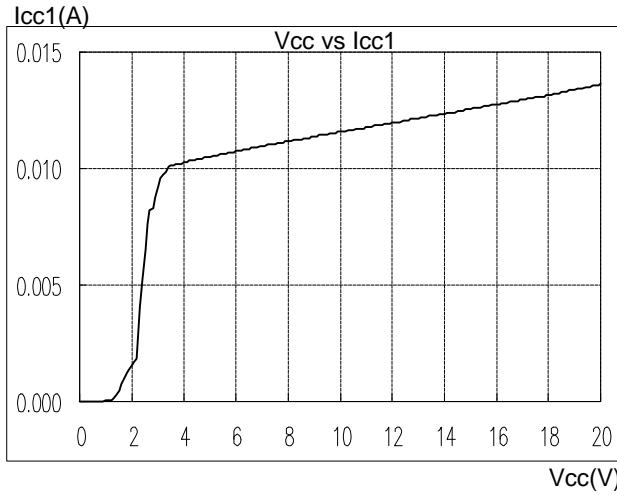

ELECTRICAL CHARACTERISTIC CURVES (Continued)

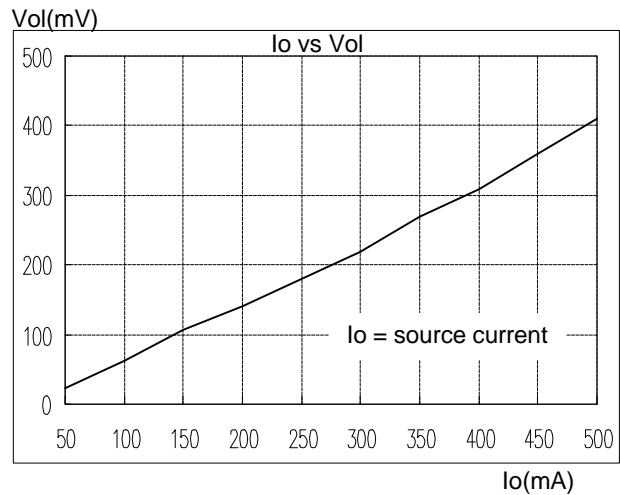
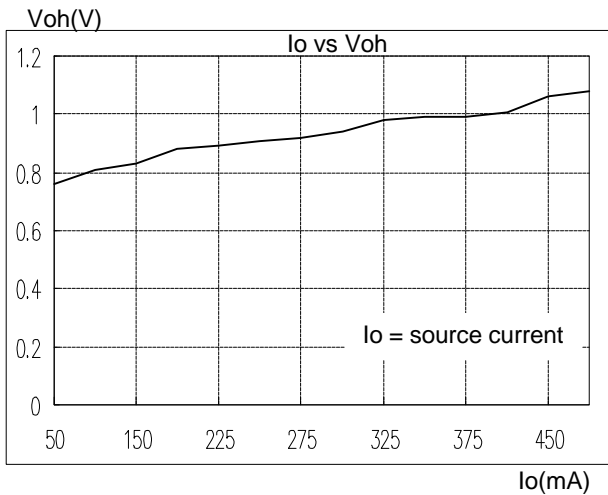
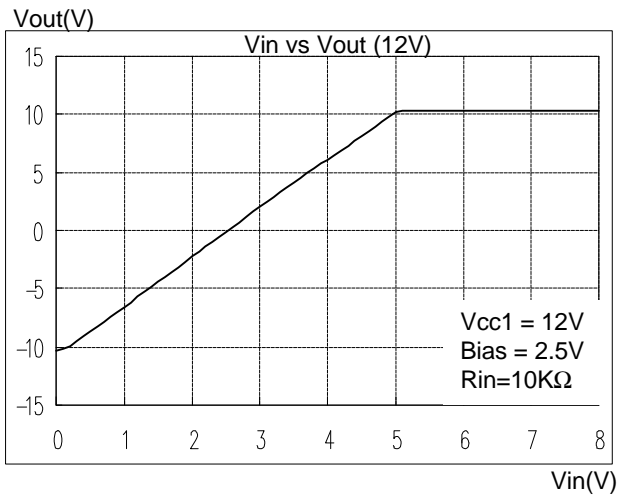
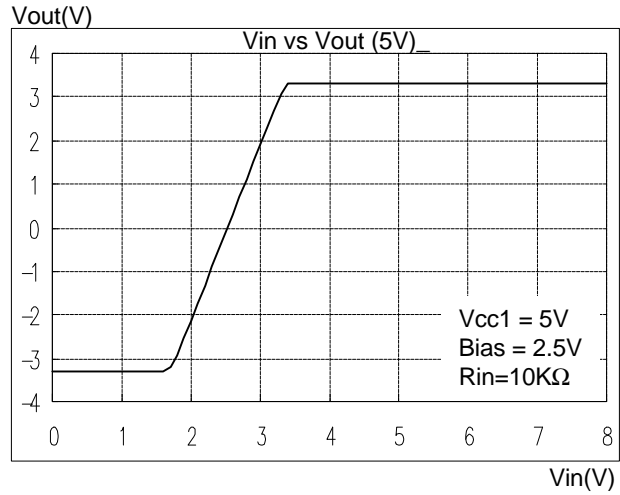
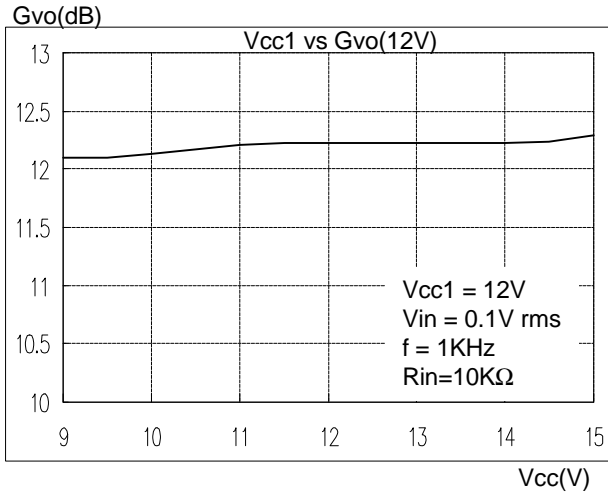

ELECTRICAL CHARACTERISTIC CURVES (Continued)

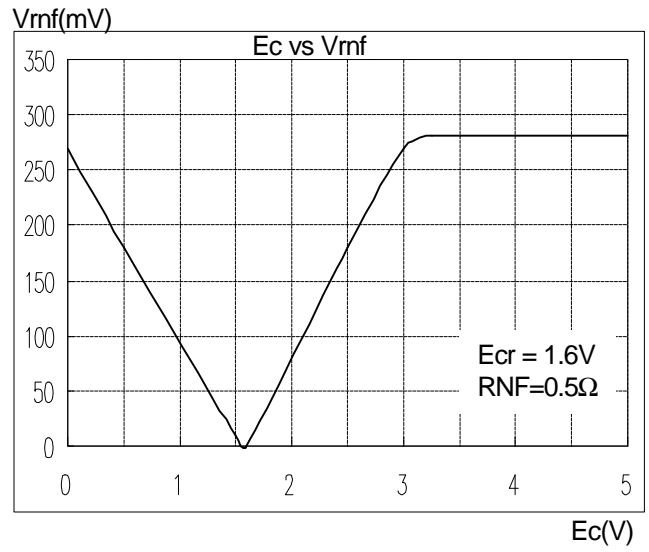
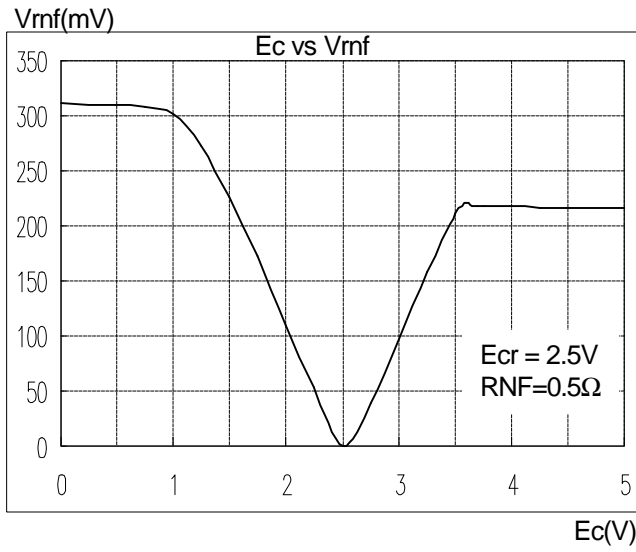

TEST CIRCUIT 1

BTL DRIVE PART

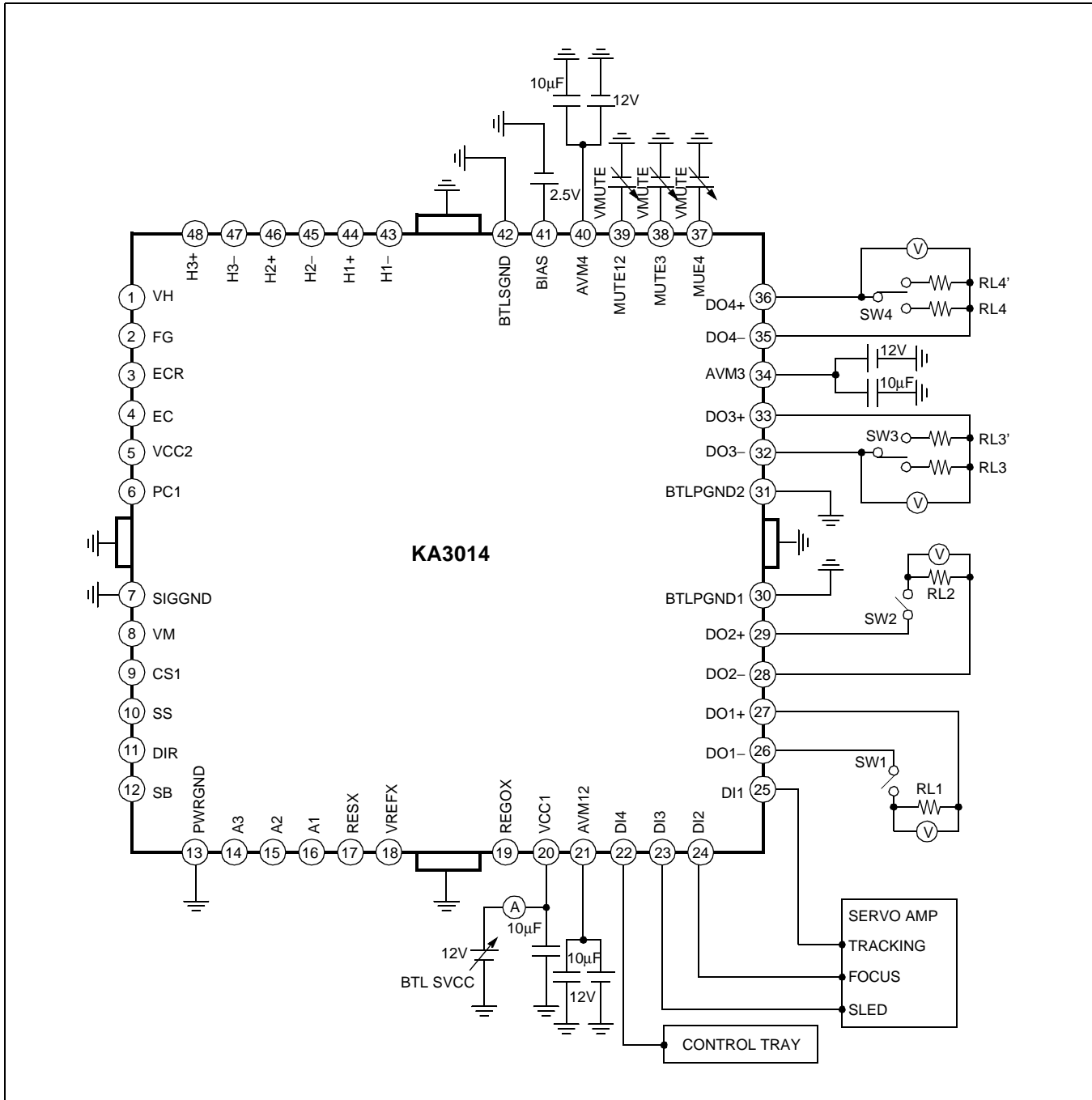

TEST CIRCUIT 2

SPINDLE MOTOR DRIVE PART

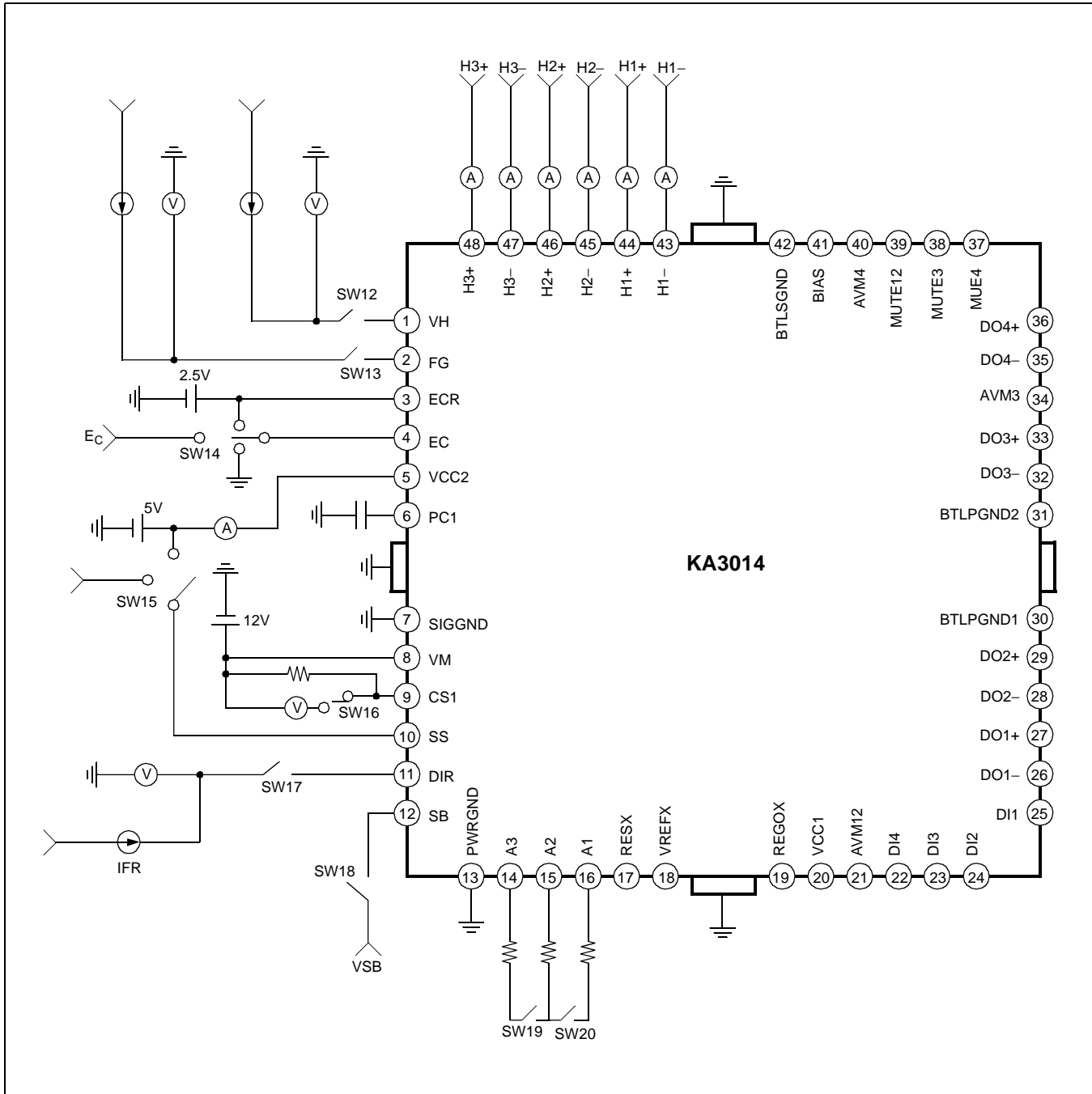

APPLICATION CIRCUIT

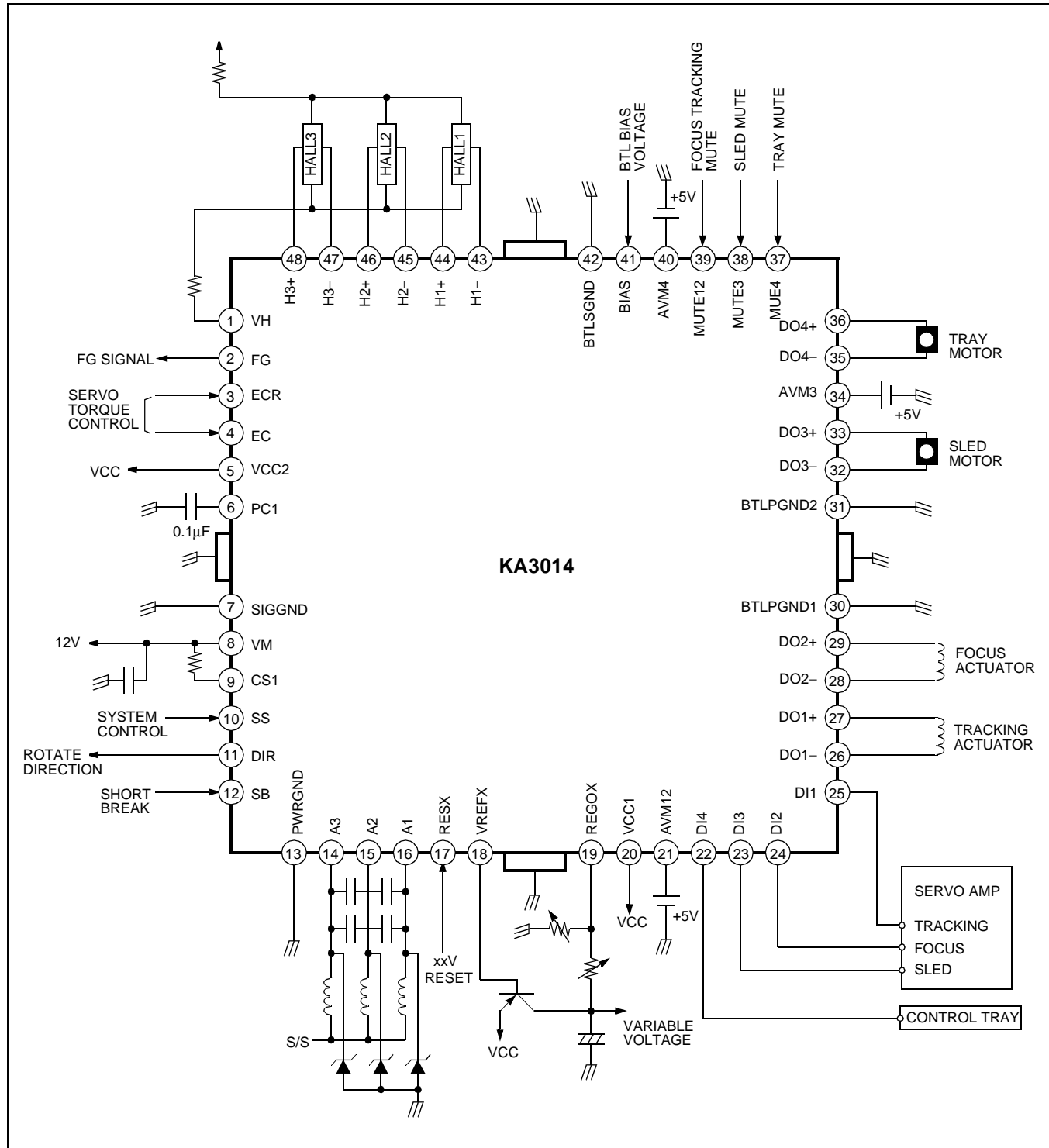



## TRADEMARKS

The following are registered and unregistered trademarks Fairchild Semiconductor owns or is authorized to use and is not intended to be an exhaustive list of all such trademarks.

ACEx™	ISOPLANAR™
CoolFET™	MICROWIRE™
CROSSVOLT™	POP™
E <sup>2</sup> CMOS™	PowerTrench™
FACT™	QS™
FACT Quiet Series™	Quiet Series™
FAST®	SuperSOT™-3
FASTr™	SuperSOT™-6
GTO™	SuperSOT™-8
HiSeC™	TinyLogic™

## DISCLAIMER

FAIRCHILD SEMICONDUCTOR RESERVES THE RIGHT TO MAKE CHANGES WITHOUT FURTHER NOTICE TO ANY PRODUCTS HEREIN TO IMPROVE RELIABILITY, FUNCTION OR DESIGN. FAIRCHILD DOES NOT ASSUME ANY LIABILITY ARISING OUT OF THE APPLICATION OR USE OF ANY PRODUCT OR CIRCUIT DESCRIBED HEREIN; NEITHER DOES IT CONVEY ANY LICENSE UNDER ITS PATENT RIGHTS, NOR THE RIGHTS OF OTHERS.

## LIFE SUPPORT POLICY

FAIRCHILD'S PRODUCTS ARE NOT AUTHORIZED FOR USE AS CRITICAL COMPONENTS IN LIFE SUPPORT DEVICES OR SYSTEMS WITHOUT THE EXPRESS WRITTEN APPROVAL OF FAIRCHILD SEMICONDUCTOR CORPORATION. As used herein:

1. Life support devices or systems are devices or systems which, (a) are intended for surgical implant into the body, or (b) support or sustain life, or (c) whose failure to perform when properly used in accordance with instructions for use provided in the labeling, can be reasonably expected to result in significant injury to the user.
2. A critical component is any component of a life support device or system whose failure to perform can be reasonably expected to cause the failure of the life support device or system, or to affect its safety or effectiveness.

## PRODUCT STATUS DEFINITIONS

### Definition of Terms

Datasheet Identification	Product Status	Definition
Advance Information	Formative or In Design	This datasheet contains the design specifications for product development. Specifications may change in any manner without notice.
Preliminary	First Production	This datasheet contains preliminary data, and supplementary data will be published at a later date. Fairchild Semiconductor reserves the right to make changes at any time without notice in order to improve design.
No Identification Needed	Full Production	This datasheet contains final specifications. Fairchild Semiconductor reserves the right to make changes at any time without notice in order to improve design.
Obsolete	Not In Production	This datasheet contains specifications on a product that has been discontinued by Fairchild semiconductor. The datasheet is printed for reference information only.