

SPINDLE MOTOR DRIVER

The KA3016D is a monolithic integrated circuit, suitable for a 3-phase spindle motor drive of a CD system.

FEATURES

- 3-phase, full-wave, linear BLDC motor driver
- Power save at stop mode
- Built-in current limiter
- Built-in TSD (Thermal shutdown) circuit
- Built-in 3X or 1X hall FG output
- Built-in hall bias circuit
- Built-in rotational direction detector
- Built-in reverse rotation preventer
- Built-in short braker
- Corresponds to 3.3V or 5V DSP

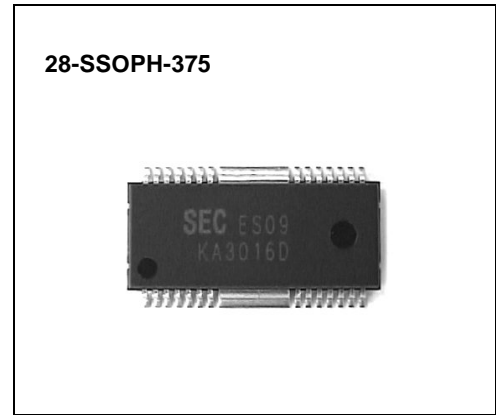

ORDERING INFORMATION

Device	Package	Operating Temperature
KA3016D	28-SSOPH-375	-25°C ~ +75°C

BLOCK DIAGRAM

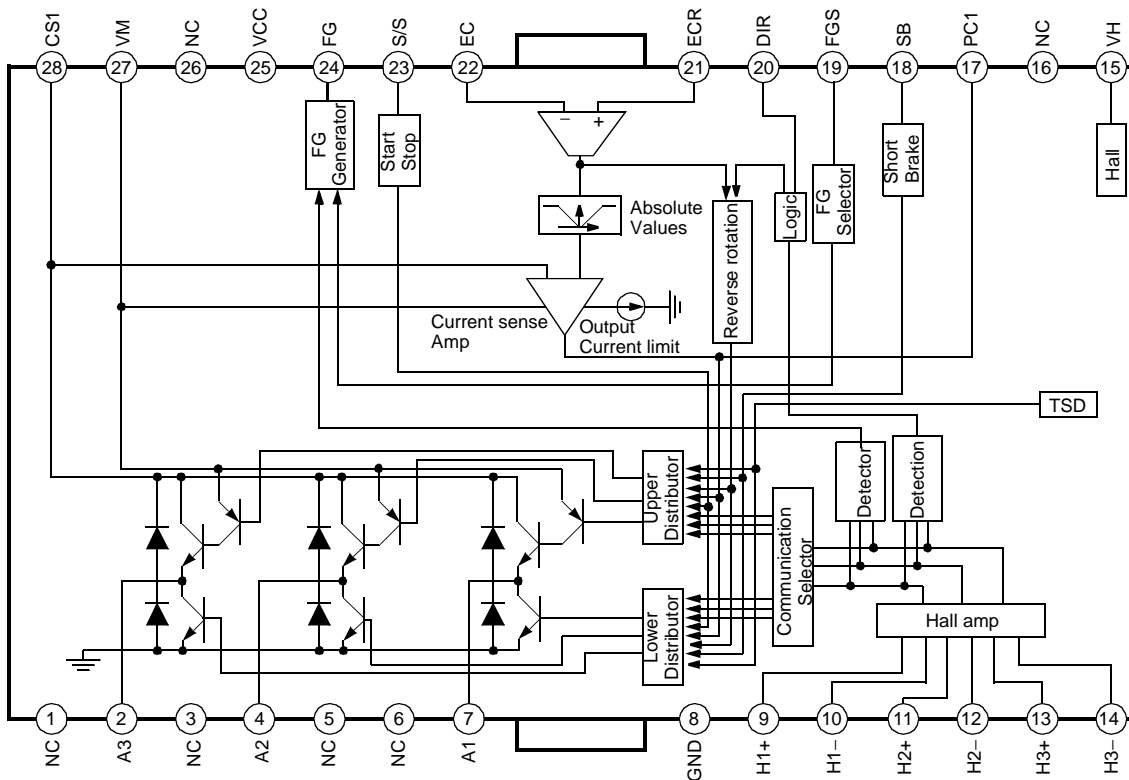

PIN CONFIGURATION

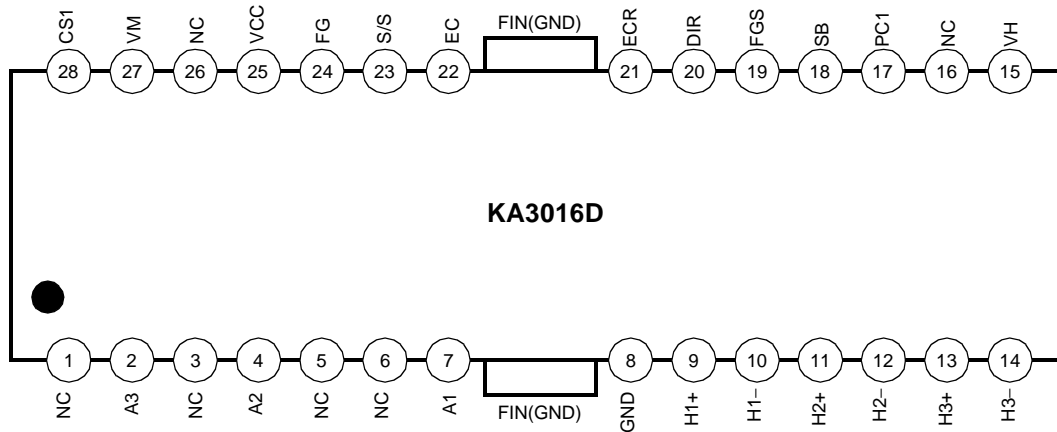

PIN DESCRIPTIONS

Pin No.	Symbol	I/O	Description	Pin No.	Symbol	I/O	Description
1	NC	–	No connection	15	VH	I	Hall bias
2	A3	O	Output (A3)	16	NC	–	No connection
3	NC	–	No connection	17	PC1	–	Phase compensation capacitor
4	A2	O	Output (A2)	18	SB	I	Short brake
5	NC	–	No connection	19	FGS	I	Frequency generation selection
6	NC	–	No connection	20	DIR	O	Rotational direction output
7	A1	O	Output (A1)	21	ECR	I	Output current control reference
8	GND	–	Ground	22	EC	I	Output current control voltage
9	H1+	I	Hall signal (H1+)	23	S/S	I	Power save (Start/Stop switch)
10	H1–	I	Hall signal (H1–)	24	FG	O	Frequency generation waveform (3X or 1X hall frequency)
11	H2+	I	Hall signal (H2+)	25	VCC	–	Supply voltage (Signal)
12	H2–	I	Hall signal (H2–)	26	NC	–	No connection
13	H3+	I	Hall signal (H3+)	27	VM	–	Supply voltage (Motor)
14	H3–	I	Hall signal (H3–)	28	CS1	–	Output current detection

EQUIVALENT CIRCUITS

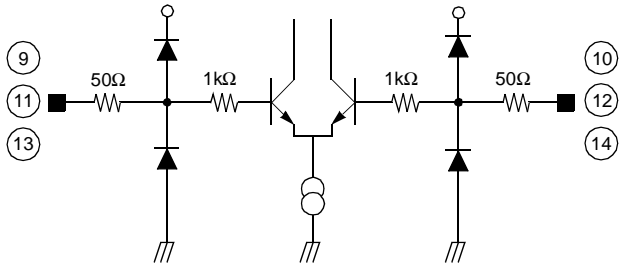
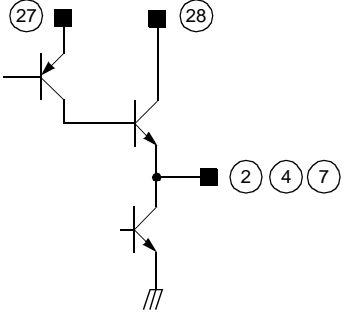
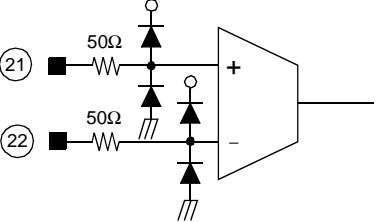
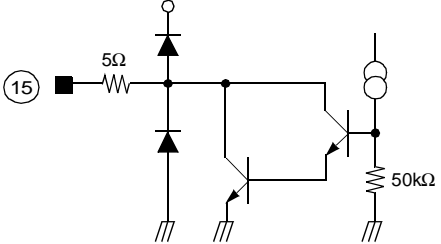
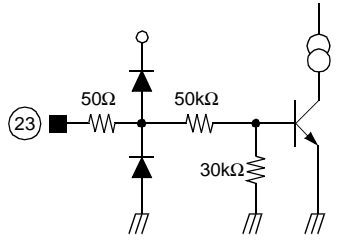
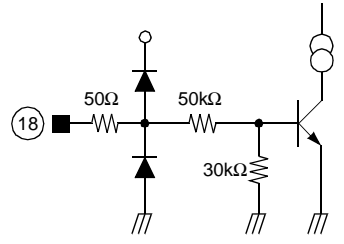
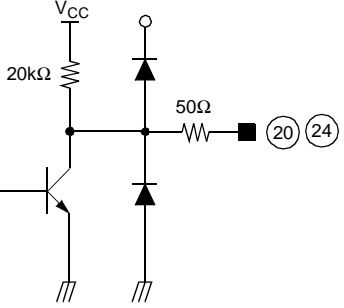
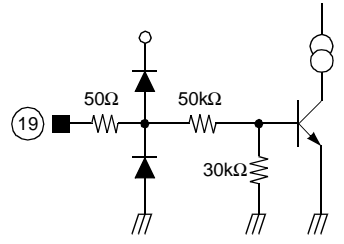
Hall input	Driver output
	
Torque control input	Hall bias input
	
Current detector	Start / Stop
	
Dir or FG output	FGS input
	

ABSOLUTE MAXIMUM RATING (Ta=25°C)

Characteristics	Symbol	Value	Unit
Maximum supply voltage (Signal)	V _{CCMAX}	7	V
Maximum supply voltage (Motor)	V _{MMAX}	18	V
Power dissipation	P _D	1.7 ^{note}	W
Maximum output current	I _{OMAX}	1.3	A
Operating temperature range	T _{OPR}	-25 ~ +75	°C
Storage temperature range	T _{STG}	-55 ~ +150	°C

NOTE:

1. When mounted on 76.2mm × 114mm × 1.57mm PCB (Phenolic resin material)
2. Power dissipation is reduced 13.6 mW / °C for using above Ta=25°C
3. Do not exceed Pd and SOA (Safe operating area).

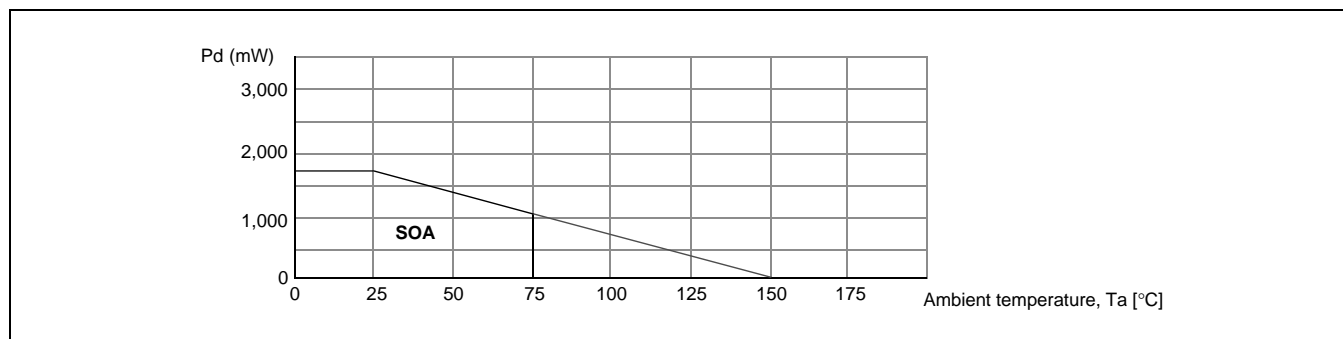
**RECOMMENDED OPERATING CONDITIONS**

Characteristics	Symbol	Min.	Typ.	Max.	Unit
Supply voltage	V _{CC}	4.5	5	5.5	V
Motor supply voltage	V _M	3.0	12	15	V

ELECTRICAL CHARACTERISTICS(Unless otherwise specified, $T_a=25^\circ\text{C}$, $V_{CC}=5\text{V}$, $V_M=12\text{V}$)

Characteristics	Symbol	Test conditions	Min.	Typ.	Max.	Unit
Quiescent circuit current	I_{CC}	–	2	5	8	mA
START / STOP						
On voltage range	V_{SSON}	Output drive on	2.5	–	V_{CC}	V
Off voltage range	V_{SSOFF}	Output driver off	0.0	–	1.0	V
HALL BIAS						
Hall bias voltage	V_{HB}	$I_{HB}=20\text{mA}$	0.4	1.0	1.8	V
HALL AMP						
Hall bias current	I_{HA}	–	–	0.5	2	μA
Common mode input range	V_{HAR}	–	1.5	–	4.0	V
Minimum input level	V_{INH}	–	100	–	–	mVpp
TORQUE CONTROL						
E_{CR} input voltage range	E_{CR}	–	0.2	–	4.0	V
E_C input voltage range	E_C	–	0.2	–	4.0	V
Offset voltage (–)	E_{COFF-}	$E_C=2.5\text{V}$	–80	–50	–20	mV
Offset voltage (+)	E_{COFF+}	$E_C=2.5\text{V}$	20	50	80	mV
E_C input current	E_{CIN}	$E_C=2.5\text{V}$	–5	0.5	5	μA
E_{CR} input current	E_{CRIN}	$E_{CR}=2.5\text{V}$	–5	0.5	5	μA
In/output gain	G_{EC}	$E_{CR}=2.5\text{V}$, $R_{CS}=0.5\Omega$	0.41	0.51	0.61	A / V
FG						
FG output voltage (H)	V_{FGH}	$I_{FG}=-10\mu\text{A}$	3.0	–	V_{CC}	V
FG output voltage (L)	V_{FGI}	$I_{FG}=10\mu\text{A}$	–	–	0.5	V
Input voltage range		–	–	50	–	%
OUTPUT BLOCK						
Saturation voltage (upper TR)	V_{OH}	$I_O=-300\text{mA}$	–	0.9	1.6	V
Saturation voltage (lower TR)	V_{OL}	$I_O=300\text{mA}$	–	0.2	0.6	V
Torque limit current	I_{TL}	$R_{CS}=0.5\Omega$	560	700	840	mA
DIRECTION DETECTOR						
Dir output voltage (H)	V_{DIRH}	$I_{FG}=-10\mu\text{A}$	3.0	–	V_{CC}	V
Dir output voltage (L)	V_{DIRL}	$I_{FG}=10\mu\text{A}$	–	–	0.5	V

ELECTRICAL CHARACTERISTICS (Continued)

(Unless otherwise specified, Ta=25°C, VCC=5V, VM=12V)

Characteristics	Symbol	Test conditions	Min.	Typ.	Max.	Unit
FG SELECTION						
3X frequency selection	V _{FG3X}	FGS > 2.5V	2.5	–	V _{CC}	V
1X frequency selection	V _{FG1X}	FGS < 1.0	–	–	1.0	V
SHORT BRAKE						
On voltage range	V _{SBON}	–	2.5	–	V _{CC}	V
Off voltage range	V _{SBOFF}	–	0	–	1.0	V

CALCUALTION OF GAIN & TORQUE LIMIT CURRENT

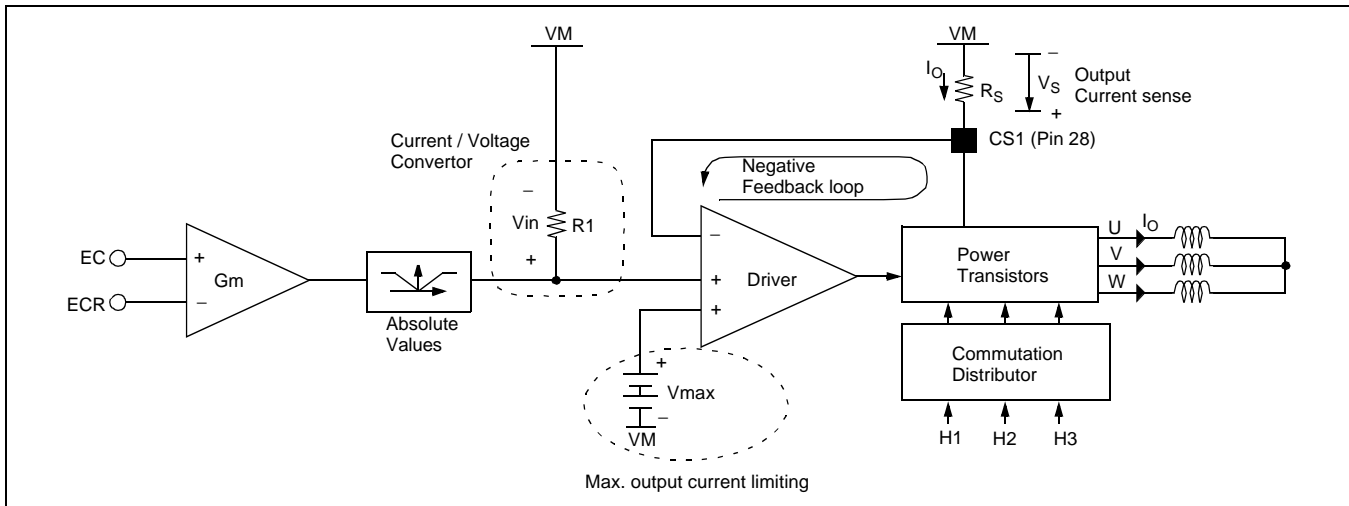

0.255 which is made from GM times R1 is fixed value within IC.

$$Gain = \frac{0.255}{R_s}$$

Vmax (see above block diagram) is setted to 350mV.

$$I_{tl}[mA] = \frac{V_{max}}{R_s} = \frac{350[mV]}{R_s}$$

APPLICATION INFORMATION

1. TORQUE CONTROL & OUTPUT CURRENT CONTROL

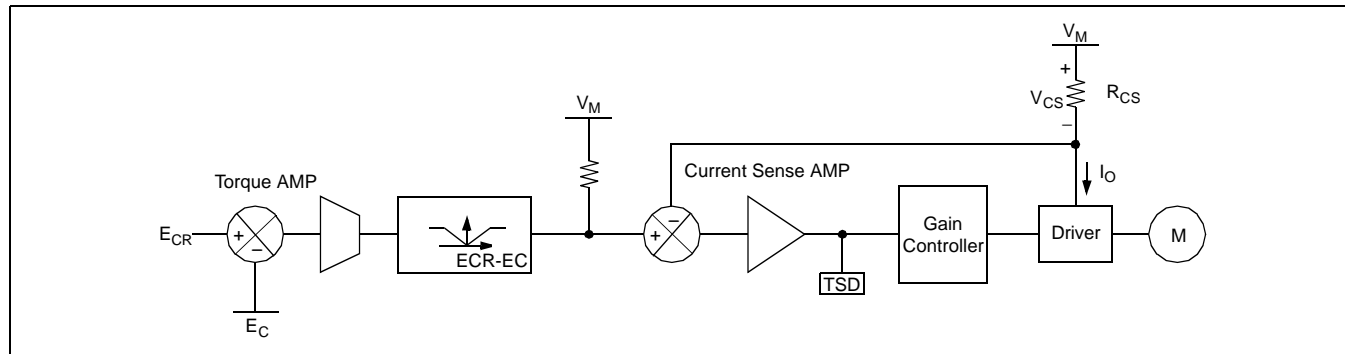

- By amplifying the voltage difference between E_C and e_{cr} from servo IC, the torque sense amp produces the input (V_{AMP}) for the current sense amp.
- The output current (I_O) is converted into the voltage (V_{CS}) through the sense resistor (R_{CS}) and compared with the V_{AMP} . By the negative feedback loop, the sensed output voltage, V_{CS} is equal to the input V_{AMP} . Therefore, the output current (I_O) is linearly controlled by the input V_{AMP} .
- As a result, the signals, E_C and E_{CR} can control the velocity of the Motor by controlling the output current (I_O) of the Driver.
- The range of the torque voltage is as shown below.

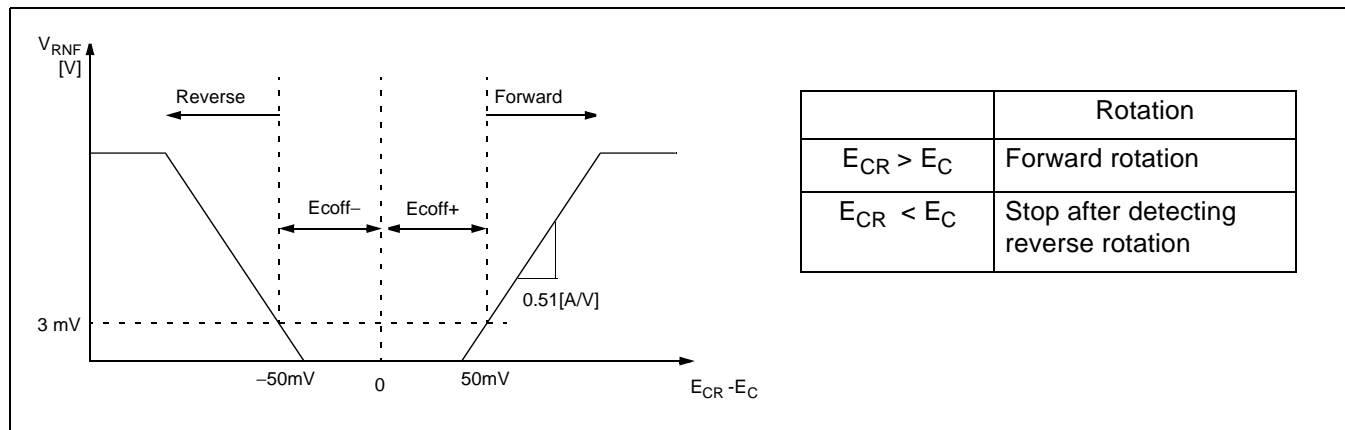

The input range of E_{CR} , E_C is 0.2V ~ 4V.

2. SHORT BRAKE

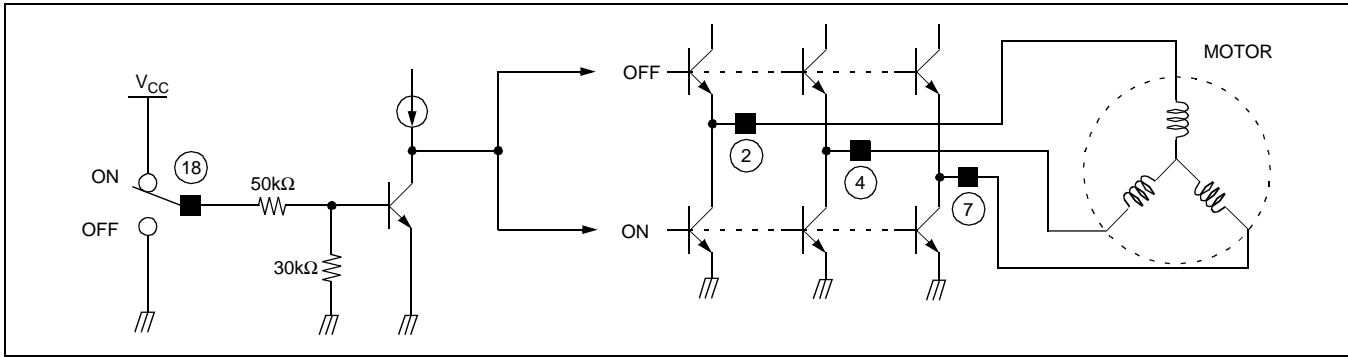

Pin # 18	Short brake
High	On
Low	Off

When the pick-up part moves from the inner to the outer spindle of the CD, the brake function of the reverse voltage is commonly employed to decrease the rotating velocity of the spindle motor. However, if the spindle motor rotates rapidly, the brake function of the reverse voltage may produce much heat at the Drive IC.

To remove this shortcoming and to enhance the braking efficiency, the short brake function is added to KA3016D. When the short brake function is active, all upper power TRs turn off and all lower power TRs turn on, so as to make the rotating velocity of the Motor slow down. But FG and DIR functions continue to operate normally.

3. POWER SAVE

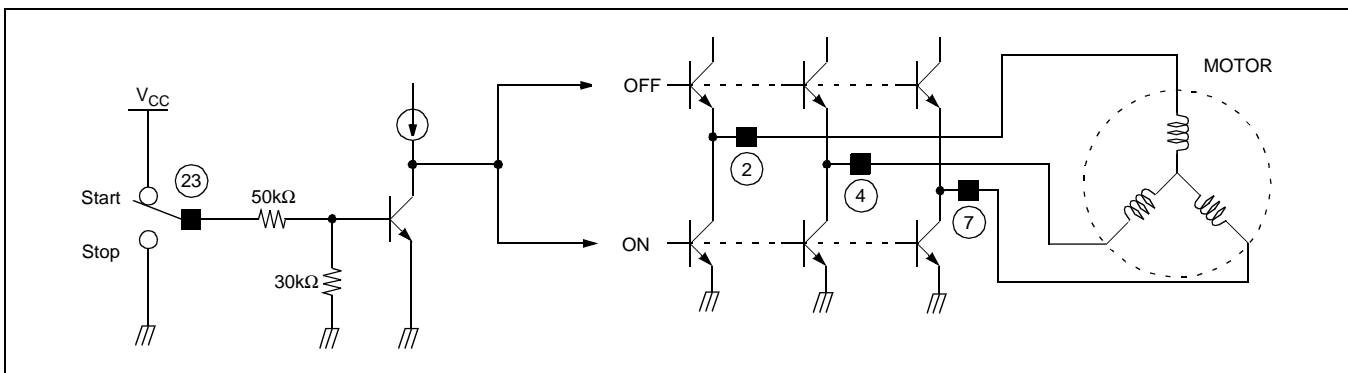

Pin # 23	Start/Stop
High	Operate
Low	Stop

When power save function active, all power TRs turn off but FG and DIR functions continue to operate normally.

4. TSD (THERMAL SHUTDOWN)

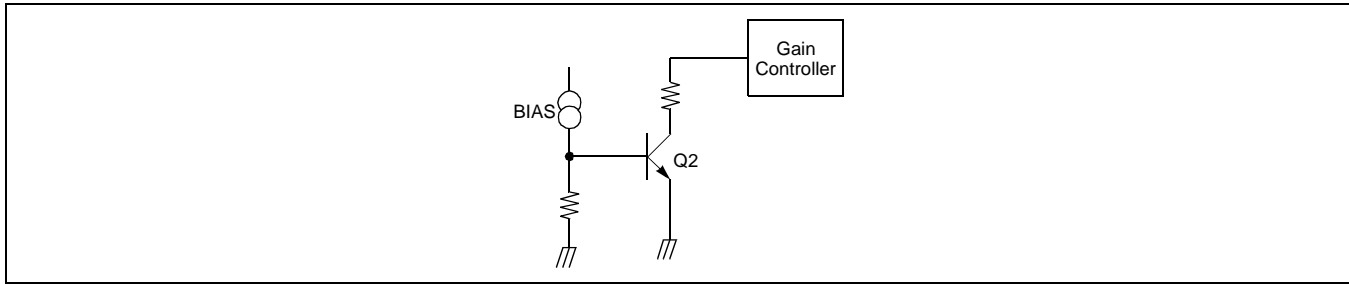

When the chip temperature rises up to about 175°C, the Q2 turns on so that the output driver will be shutdown. When the chip temperature falls off to about 150°C, then the Q2 turns off so that the driver is to operate normally. Thus, TSD has the temperature hysteresis of about 25°C.

5. ROTATIONAL DIRETION DETECTION

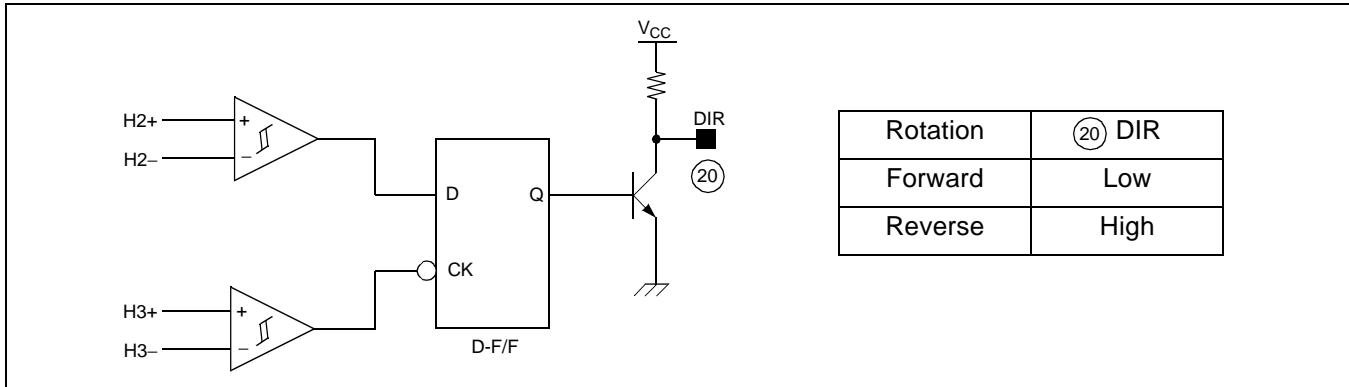

- The forward and the reverse rotations of the CD are simply detected by using the D-F/F and the truth table is shown in the above table.
- The rotational direction of the CD can be explained by the output waveforms of the hall sensors. Let the three outputs of hall sensors be H1, H2 and H3 respectively. When the spindle rotates in reverse direction, the hall sensor output waveforms are shown in Fig.(a). Thus the phases order in H1→H2→H3 with a 120° phase difference.

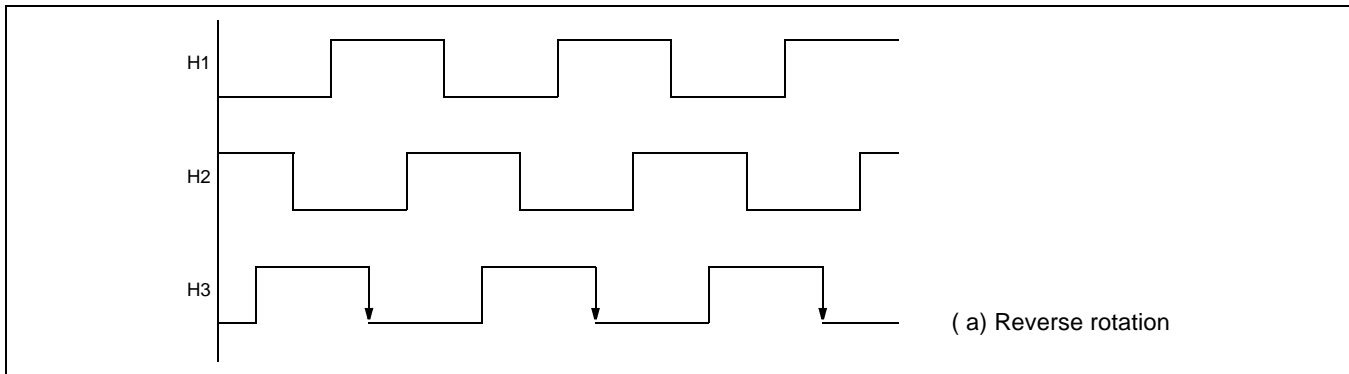

On the other hand, if the spindle rotates in forward rotation, the phase relationship is H3→H2→H1 as shown in fig.(b).

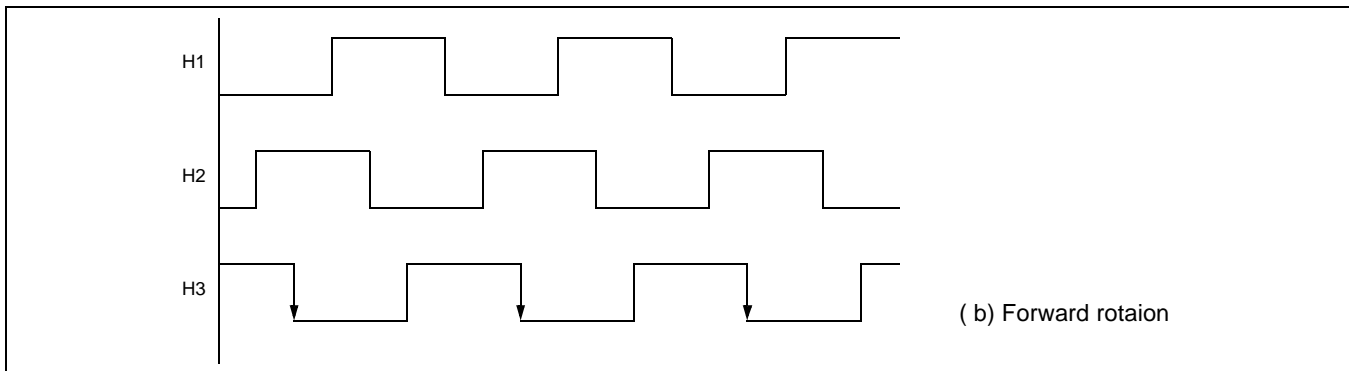

Therefore, the output of the rotational direction detector is low, when the spindle rotates forward, while high as in the case of the reverse rotation.

6. REVERSE ROTATION PREVENTION

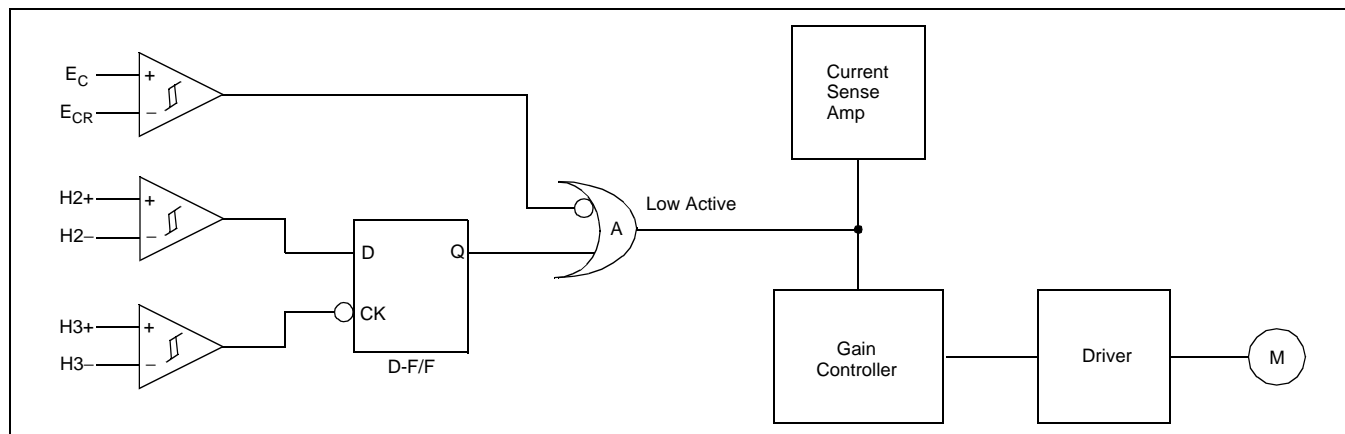

- When the output of the OR Gate, A is low, it steers all the output current of the current sense amp makes the current delivered to the gain controller zero. Thus the output current of the driver becomes zero and the motor is stopped.
- As in the state of the forward rotation, the D-F/F output, Q is high and the motor rotates normally. At this state if the control input is changed such that $E_C > E_{CR}$, then the motor rotates slowly more and more by the reverse commutation in the driver. At the moment that the motor rotates in reverse direction, the D-F/F output becomes low and the OR gate output, thus, becomes low. This prevents the motor from rotating in reverse direction. The operation principle is shown in the table and the flow chart..

Rotation	H2	H3	D-F/F (Q)	Reverse rotation preventer	
				$E_C > E_{CR}$	$E_C > E_{CR}$
Forward	H	H→L	H	Forward	-
Reverse	L	H→L	L	-	Brake and stop

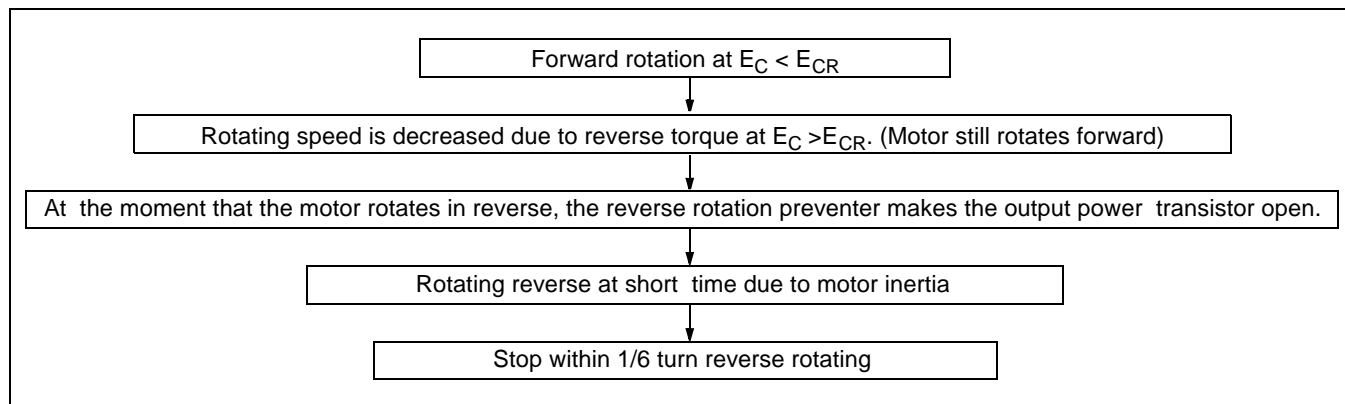

7. FG OUTPUT

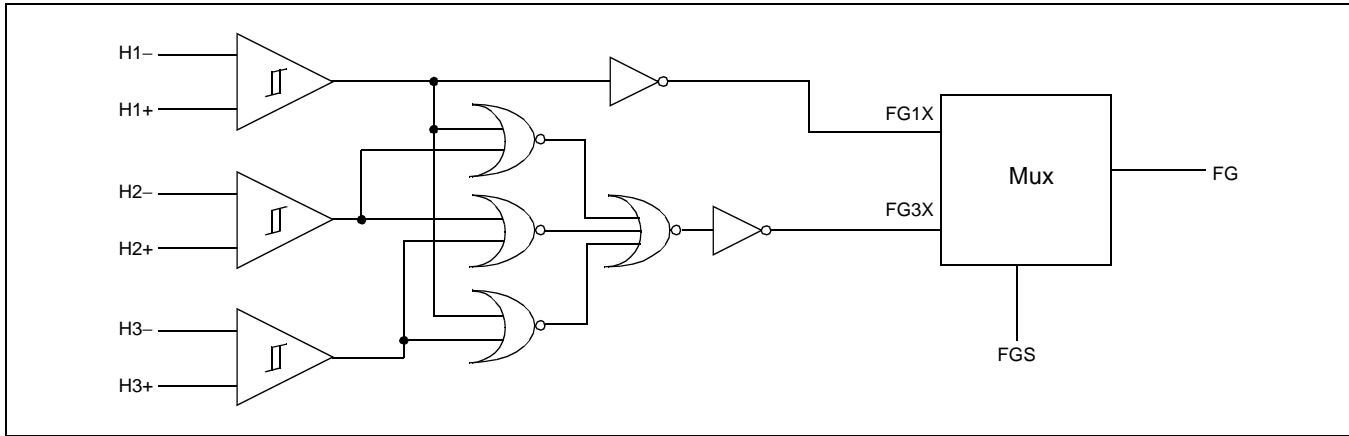

FGS	FG
GND or Open	FG1X (1X hall frequency)
V _{CC}	FG3X (3X hall frequency)

8. HALL SENSOR CONNECTION

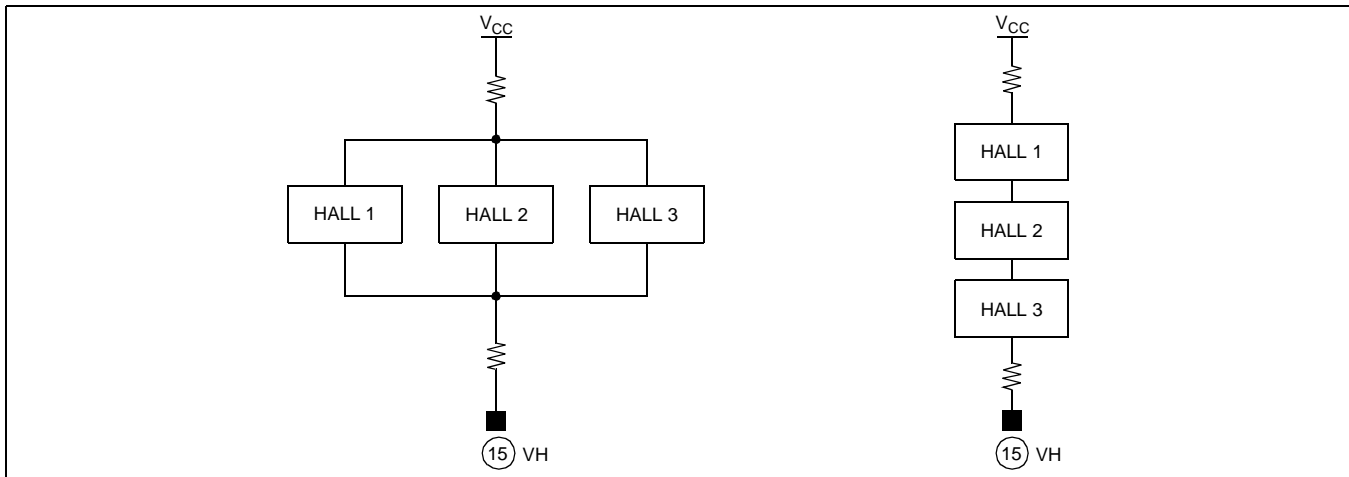

9. Connect a by-pass capacitor, $0.1\mu\text{F}$ between the supply voltage source.

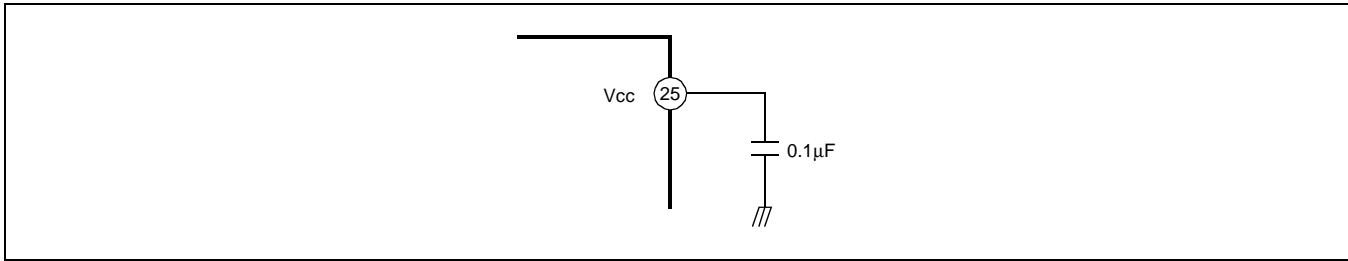

10. The heat radiation fin is connected to the internal GND of the package.
Connect that fin to the external GND.

11. INPUT-OUTPUT TIMING CHART

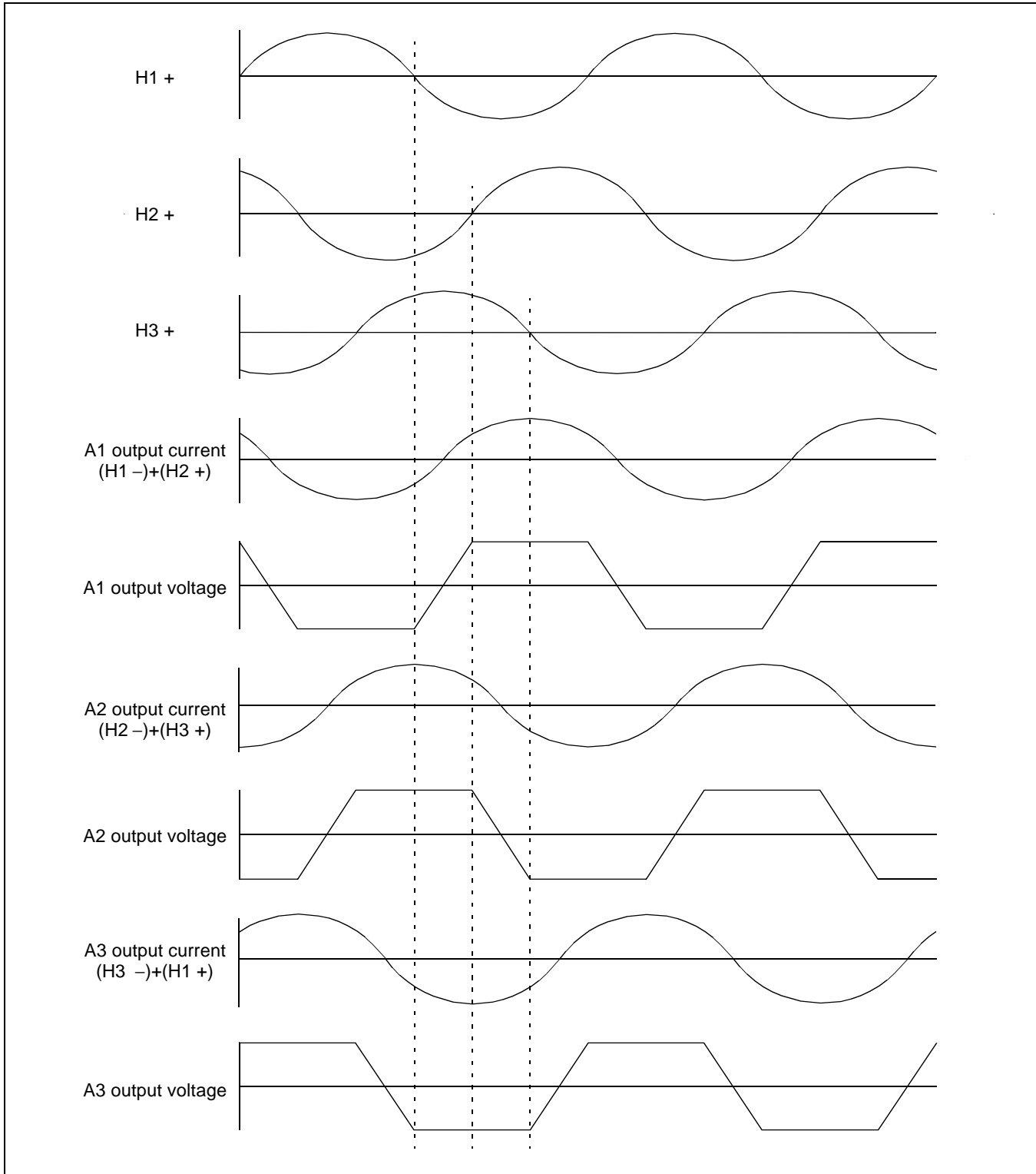

TEST CIRCUITS

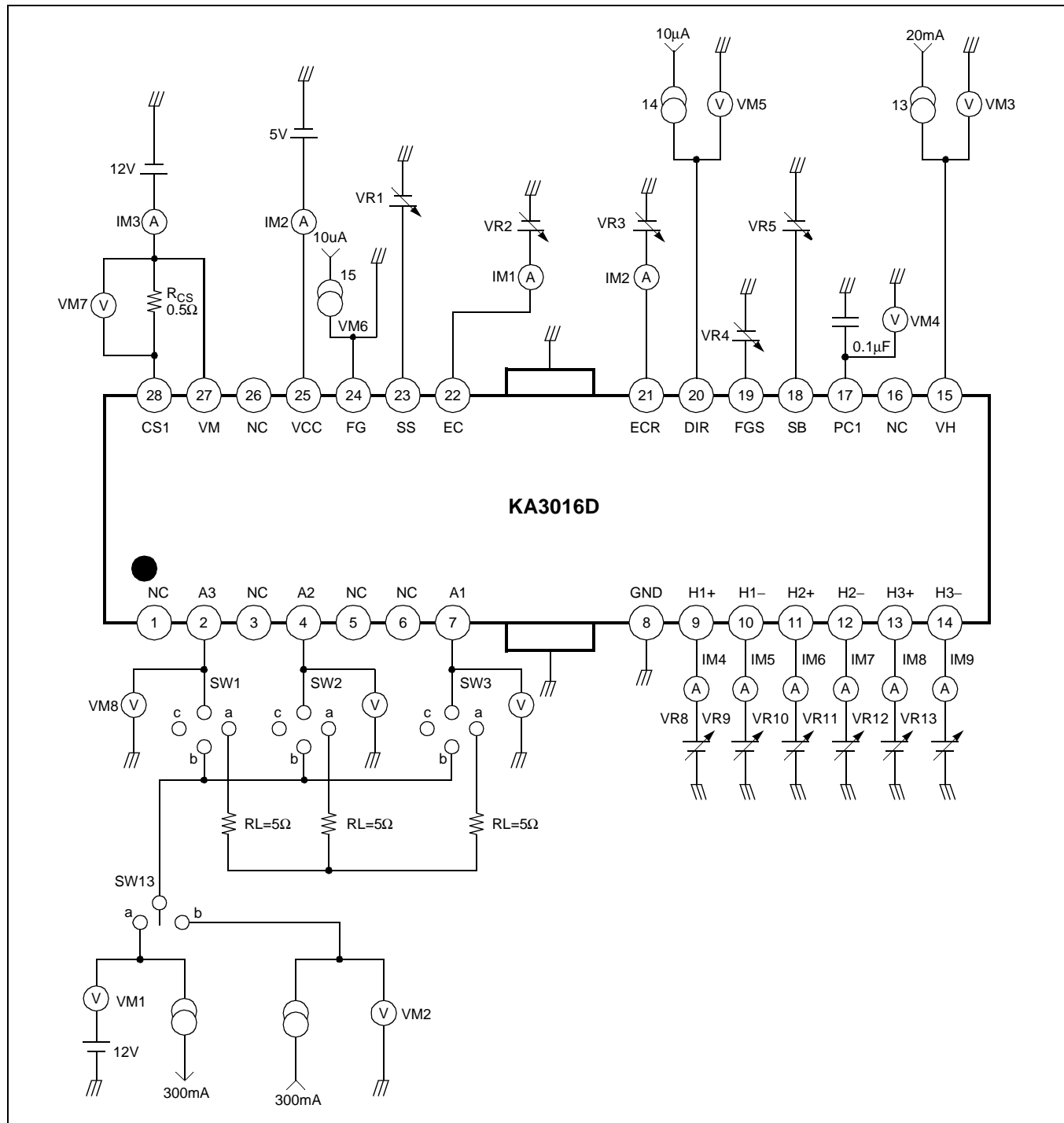

TYPICAL APPLICATION

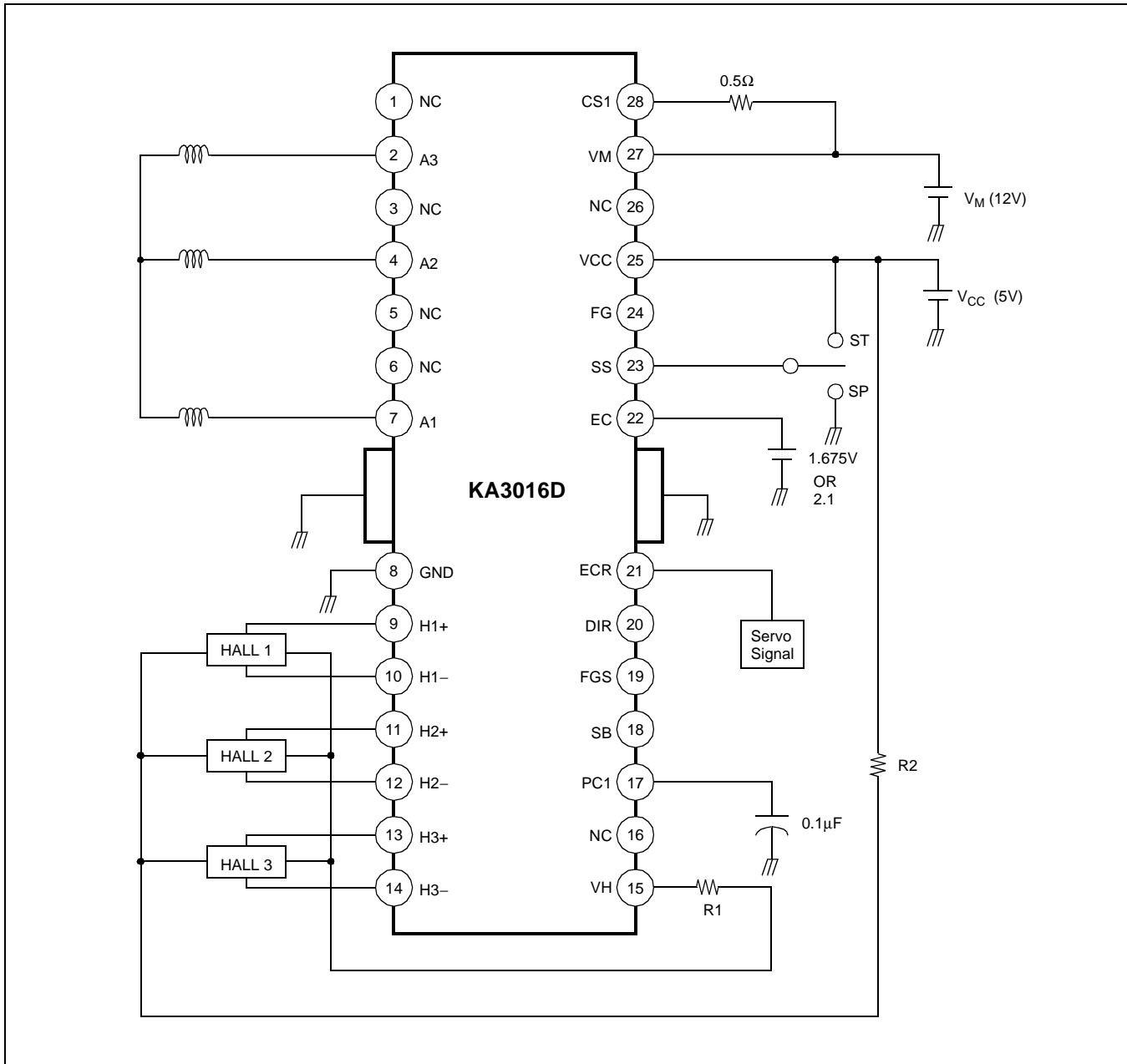

TRADEMARKS

The following are registered and unregistered trademarks Fairchild Semiconductor owns or is authorized to use and is not intended to be an exhaustive list of all such trademarks.

ACEx™	ISOPLANAR™
CoolFET™	MICROWIRE™
CROSSVOLT™	POP™
E ² CMOS™	PowerTrench™
FACT™	QS™
FACT Quiet Series™	Quiet Series™
FAST®	SuperSOT™-3
FASTr™	SuperSOT™-6
GTO™	SuperSOT™-8
HiSeC™	TinyLogic™

DISCLAIMER

FAIRCHILD SEMICONDUCTOR RESERVES THE RIGHT TO MAKE CHANGES WITHOUT FURTHER NOTICE TO ANY PRODUCTS HEREIN TO IMPROVE RELIABILITY, FUNCTION OR DESIGN. FAIRCHILD DOES NOT ASSUME ANY LIABILITY ARISING OUT OF THE APPLICATION OR USE OF ANY PRODUCT OR CIRCUIT DESCRIBED HEREIN; NEITHER DOES IT CONVEY ANY LICENSE UNDER ITS PATENT RIGHTS, NOR THE RIGHTS OF OTHERS.

LIFE SUPPORT POLICY

FAIRCHILD'S PRODUCTS ARE NOT AUTHORIZED FOR USE AS CRITICAL COMPONENTS IN LIFE SUPPORT DEVICES OR SYSTEMS WITHOUT THE EXPRESS WRITTEN APPROVAL OF FAIRCHILD SEMICONDUCTOR CORPORATION. As used herein:

1. Life support devices or systems are devices or systems which, (a) are intended for surgical implant into the body, or (b) support or sustain life, or (c) whose failure to perform when properly used in accordance with instructions for use provided in the labeling, can be reasonably expected to result in significant injury to the user.
2. A critical component is any component of a life support device or system whose failure to perform can be reasonably expected to cause the failure of the life support device or system, or to affect its safety or effectiveness.

PRODUCT STATUS DEFINITIONS

Definition of Terms

Datasheet Identification	Product Status	Definition
Advance Information	Formative or In Design	This datasheet contains the design specifications for product development. Specifications may change in any manner without notice.
Preliminary	First Production	This datasheet contains preliminary data, and supplementary data will be published at a later date. Fairchild Semiconductor reserves the right to make changes at any time without notice in order to improve design.
No Identification Needed	Full Production	This datasheet contains final specifications. Fairchild Semiconductor reserves the right to make changes at any time without notice in order to improve design.
Obsolete	Not In Production	This datasheet contains specifications on a product that has been discontinued by Fairchild semiconductor. The datasheet is printed for reference information only.