

3-CH MOTOR DRIVER

The KA3018D2 is a monolithic integrated circuit, suitable for a 3-ch motor driver which drives focus actuator, tracking actuator, and sledmotor of a CD system.

FEATURES

- 3-Channel BTL (Balanced transformer-less) driver
- Built-in variable regulator with reset (Series-REG)
- Built-in thermal shutdown circuit
- Built-in mute circuit
- Built-in normal op-amp
- Operating supply voltage: 4.5 ~ 5.5V
- Corresponds to 3.3V or 5V DSP



ORDERING INFORMATION

Device	Package	Operating Temperature
KA3018D2	28-SSOPH-300	-35°C ~ +85°C

BLOCK DIAGRAM

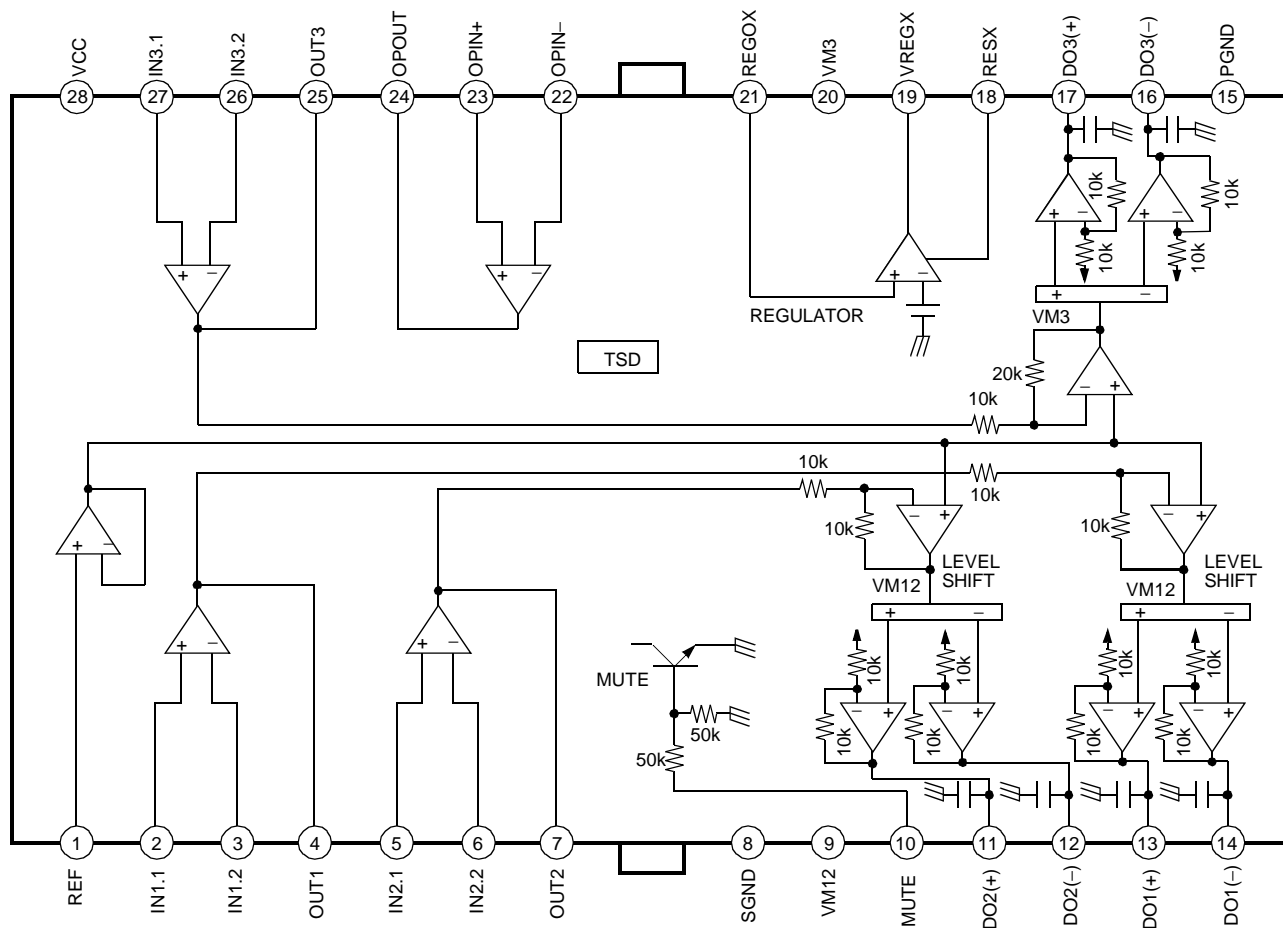

PIN CONFIGURATION

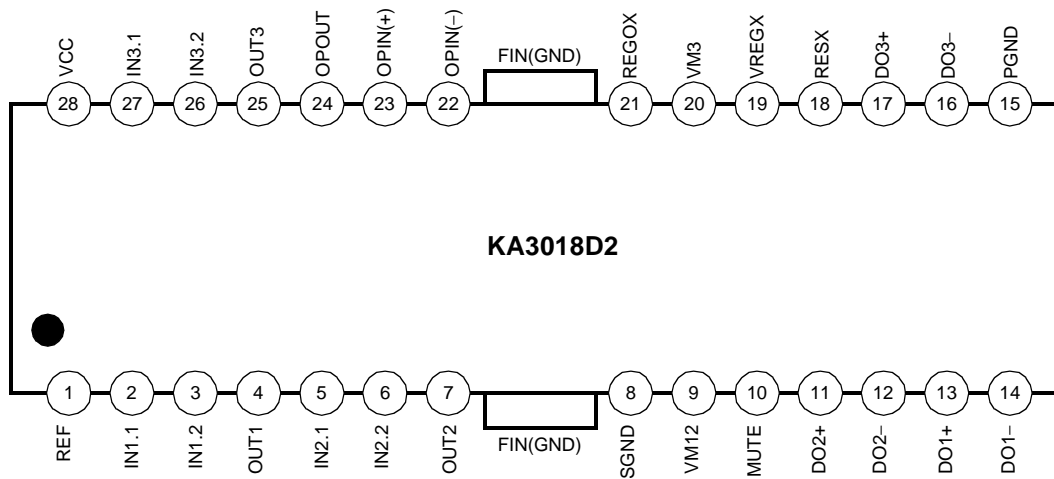

PIN DESCRIPTION

Pin No.	Symbol	I/O	Description	Pin No.	Symbol	I/O	Description
1	REF	I	Bias voltage input	15	PGND	-	Power ground
2	IN1.1	I	Op-amp CH1 input (+)	16	DO3-	O	Drive3 output (-)
3	IN1.2	I	Op-amp CH1 input (-)	17	DO3+	O	Drive3 output (+)
4	OUT1	O	Op-amp CH1 output	18	RESX	I	Regulator reset
5	IN2.1	I	Op-amp CH2 input (+)	19	VREGX	O	Regulator output
6	IN2.2	I	Op-amp CH2 input (-)	20	VM3	-	BTL CH3 supply VTG
7	OUT2	O	Op-amp CH2 output	21	REGOX	I	Regulator
8	SGND	-	Signal ground	22	OPIN(-)	I	Op-amp input (-)
9	VM12	-	BTL CH1, 2 supply VTG	23	OPIN(+)	I	Op-amp input (+)
10	MUTE	I	Mute	24	OPOUT	O	Op-amp output
11	DO2+	O	Drive2 output (+)	25	OUT3	O	Op-amp CH3 output
12	DO2-	O	Drive2 output (-)	26	IN3.2	I	Op-amp CH3 input (-)
13	DO1+	O	Drive1 output (+)	27	IN3.1	I	Op-amp CH3 input (+)
14	DO1-	O	Drive1 output (-)	28	VCC	-	Supply voltage

EQUIVALENT CIRCUITS

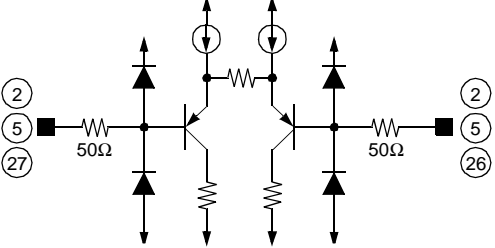
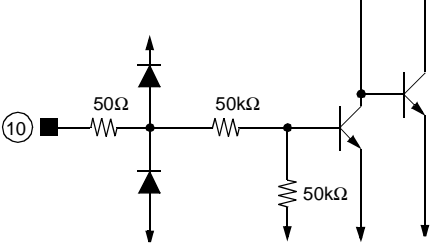
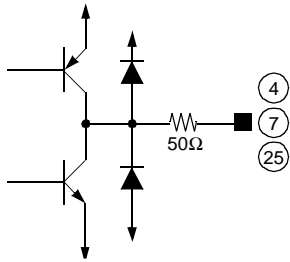
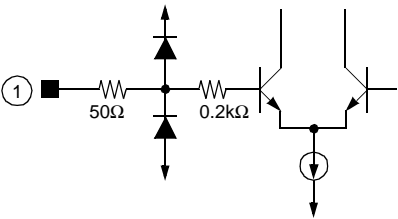
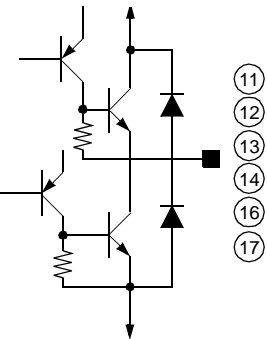
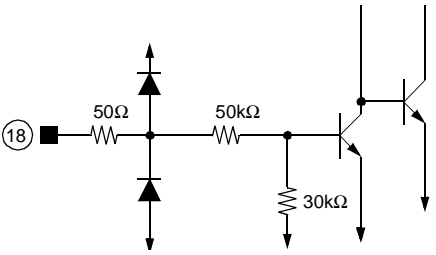
<p style="text-align: center;">Error amp input</p> 	<p style="text-align: center;">Mute input</p> 
<p style="text-align: center;">Error amp output</p> 	<p style="text-align: center;">Signal reference input</p> 
<p style="text-align: center;">Power output</p> 	<p style="text-align: center;">Regulator reset</p> 

EQUIVALENT CIRCUITS (Continued)

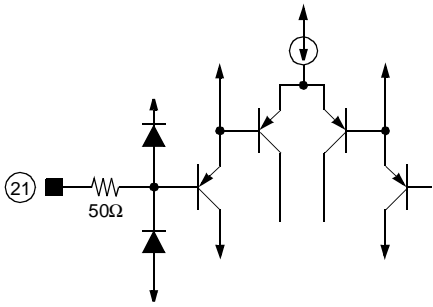
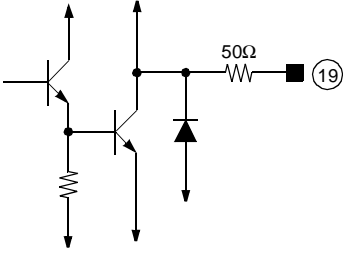
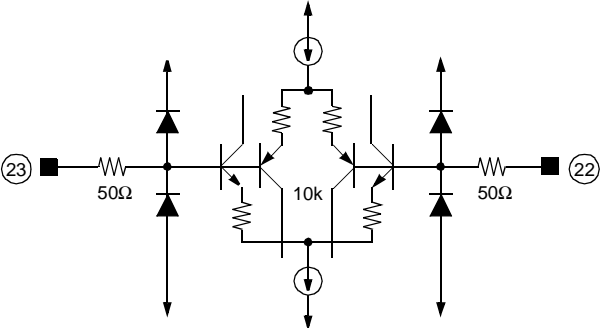
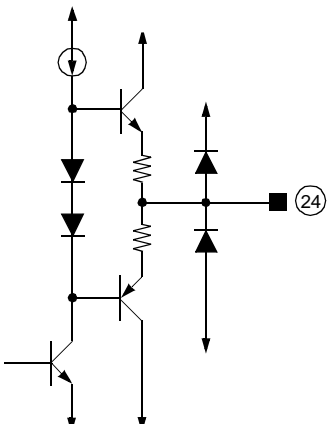
Regulator	Regulator output
	
General op amp input	Normal op amp output
	

ABSOLUTE MAXIMUM RATINGS (Ta=25°C)

Characteristics	Symbol	Value	Unit
Maximum supply voltage	V_{CCMAX}	7	V
Power dissipation	P_D	@1.4	W
Operating temperature range	T_{OPR}	-35 ~ +85	°C
Storage temperature range	T_{STG}	-55 ~ +150	°C

@:

1. When mounted on a 76.2mm × 114mm × 1.57mm PCB (Phenolic resin material).
2. Power dissipation reduces 11.2mW / °C for using above Ta = 25°C
3. Do not exceed Pd and SOA (Safe operating area).

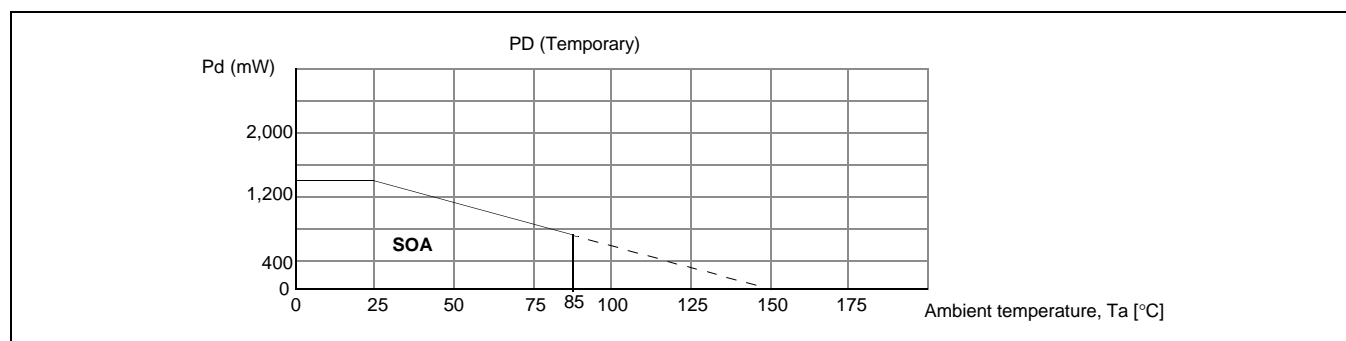
**RECOMMENDED OPERATING CONDITIONS**

Characteristics	Symbol	Min.	Typ.	Max.	Unit
Supply voltage	V_{CC}	4.5	–	5.5	V

ELECTRICAL CHARACTERISTICS

(Unless otherwise specified, $T_a=25^\circ\text{C}$, $V_{CC}=V_{M12}=V_{M3}=5\text{V}$)

Characteristics	Symbol	Test conditions	Min.	Typ.	Max.	Unit
Quiescent current	I_{CC}	$V_{IN}=0\text{V}$	–	8	12	mA
Mute on current	I_{MUTE}	Mute pin=GND	–	2.5	4	mA
Mute on voltage	V_{MON}	–	–	–	0.5	V
Mute off voltage	V_{MOFF}	–	2	–	–	V
BTL DRIVE PART						
Input offset voltage	V_{IO}	–	–20	–	+20	mV
Output offset voltage	V_{OO}	$V_{IN}=2.5\text{V}$	–50	–	+50	mV
Maximum output voltage 1	V_{OM1}	$V_{CC}=5\text{V}$, $R_L=8\Omega$ (CH1, 2)	2.7	3.4	–	V
Maximum output voltage 2	V_{OM2}	$V_{CC}=5\text{V}$, $R_L=24\Omega$ (CH3)	3	3.8	–	V
Closed loop voltage gain 1	G_{VC1}	$f=1\text{kHz}$, $V_{IN}=0.1V_{RMS}$ (CH1, 2)	10.5	12	13.5	dB
Closed loop voltage gain 2	G_{VC2}	$f=1\text{kHz}$, $V_{IN}=0.1V_{RMS}$ (CH3)	16	18	20	dB
Ripple rejection ratio	RR	$V_{IN}=0.1V_{RMS}$, $f=120\text{Hz}$	–	60	–	dB
Slew rate	SR	$V_O=2\text{Vp-p}$, $f=120\text{kHz}$	–	0.8	–	V/ μs
GENERAL OP AMP PART						
Input offset voltage	V_{OFOP}	–	–10	–	+10	mV
Input bias current	I_{BOP}	–	–	–	300	nA
High level output voltage	V_{OHOP}	$V_{CC}=5\text{V}$, $R_L=1\text{k}\Omega$	3	4	–	V
Low level output voltage	V_{OLOP}	$V_{CC}=5\text{V}$, $R_L=1\text{k}\Omega$	0.7	1	1.3	V
Output sink current	I_{SINK}	$V_{CC}=5\text{V}$, $R_L=50\Omega$	10	20	–	mA
Output source current	I_{SOURCE}	$V_{CC}=5\text{V}$, $R_L=50\Omega$	10	20	–	mA
Open loop voltage gain	G_{VO}	$V_{IN}=-75\text{dB}$, $f=1\text{kHz}$	–	75	–	dB
Ripple rejection ratio	RR_{OP}	$V_{IN}=-20\text{dB}$, $f=120\text{Hz}$	–	65	–	dB
Slew rate	SR_{OP}	$f=120\text{kHz}$, 2Vp-p	–	1	–	V/ μs
Common mode rejection ratio	CMRR	$V_{IN}=-20\text{dB}$, $f=1\text{kHz}$	–	80	–	dB
Common mode input range	V_{ICM}	$V_{CC}=5\text{V}$	–0.3	–	4.5	V

ELECTRICAL CHARACTERISTICS (Continued)(Unless otherwise specified, $T_a=25^\circ\text{C}$, $V_{CC}=V_{M12}=V_{M3}=5\text{V}$)

Characteristics	Symbol	Test conditions	Min.	Typ.	Max.	Unit
ERROR AMP PART						
Input offset voltage	V_{OFOP}	–	–10	–	+10	mV
Input bias current	I_{BOP}	–	–	–	300	nA
High level output voltage	V_{OHOP}	$V_{CC}=5\text{V}$, $R_L=10\text{k}\Omega$	4.5	4.8	–	V
Low level output voltage	V_{OLOP}	$V_{CC}=5\text{V}$, $R_L=10\text{k}\Omega$	–	0.2	0.5	V
Output sink current	V_{SINK}	$V_{CC}=5\text{V}$, $R_L=1\text{k}\Omega$	2	4	–	mA
Output source current	V_{SOURCE}	$V_{CC}=5\text{V}$, $R_L=1\text{k}\Omega$	2	4	–	mA
Slew rate	SR_{OP}	$f=120\text{kHz}$, 2Vp-p	–	1	–	V/ μs
VARIABLE REGULATOR PART						
Regulator output voltage	V_{reg}	$I_L=100\text{mA}$	3.0	–	4.5	V
Load regulation	ΔV_{R1}	$I_L=0 \rightarrow 200\text{mA}$	–40	–	10	mV
Line regulation	ΔV_{CC}	$I_L=200\text{mA}$, $V_{CC}=5 \rightarrow 8\text{V}$	–20	–	30	mV

APPLICATION INFORMATION

1. REFERENCE INPUT & ALL MUTE FUNCTION

Pin 1 (REF) is a reference input pin.

- Reference input
The applied voltage at the reference input pin must be between 1.5V and 3.5V, when $V_{CC}=5V$.
- Mute input
The following input conditions must be satisfied for the normal mute function.

All mute on voltage	Below 0.5V	Mute function operation
All mute off voltage	Above 2V	Normal operation

2. PROTECTION FUNCTION

Thermal shutdown (TSD)

- If the chip temperature rises above 175°C, the thermal shutdown (TSD) circuit is activated and the output circuit is in the mute state, that is off state.
The TSD circuit has a temperature hysteresis of 25°C.

3. REGULATOR & RESET FUNCTION

The regulator configuration with the external components is illustrated in figure 1.

- The external circuit is composed of the KSB772 PNP transistor and a capacitor about 33 μ F, and two feedback resistors R1, R2. The capacitor operates both as a ripple eliminator and as compensation of the feedback loop.
- The output voltage (REG OUT) is

$$V_{OUT} = \left(1 + \frac{R1}{R2}\right) \times 25 = 5[V] \quad (\text{Where } R1 = R2)$$

- When the voltage of pin 18 (Vreset) is 0V, the regulator reset function is activated, and the output voltage (REG OUT) becomes 0V. Otherwise, if the voltage of pin 18 is 5V, the regulator operates properly.

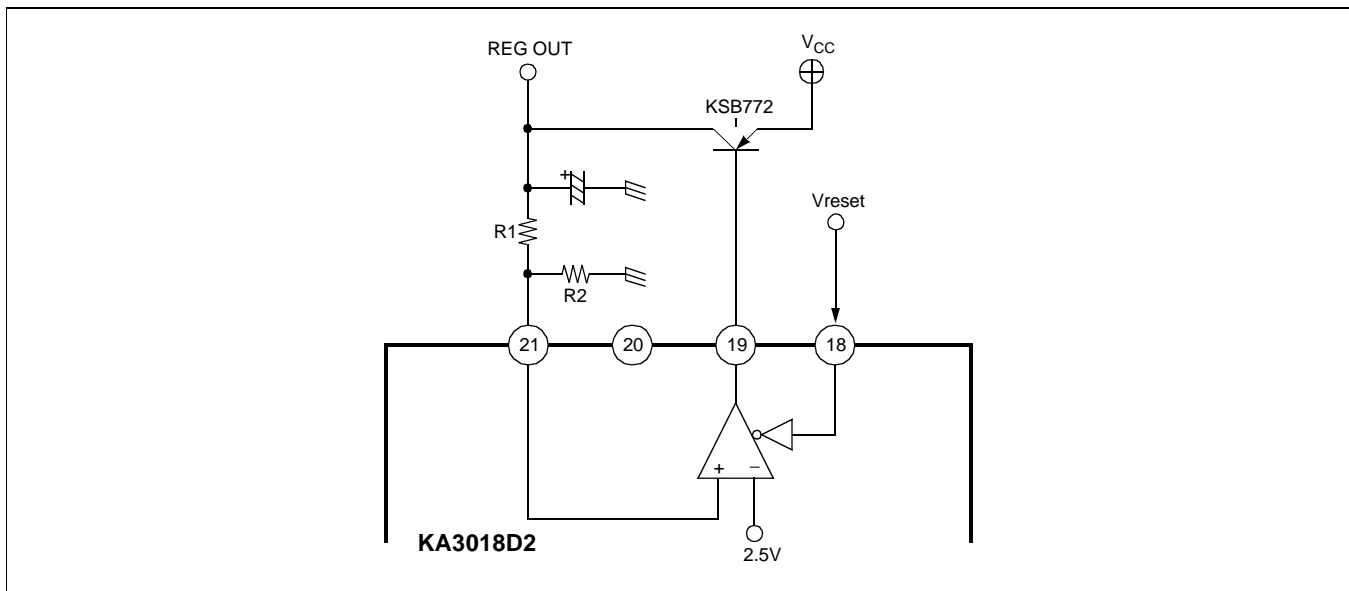

Figure 1. Regulator circuit

4. FOCUS / TRACKING ACTUATOR SLED MOTOR DRIVE PART

- The reference voltage, REF is given externally through pin 1.
- The error amp output signal is amplified by $R2/R1$ times and then fed to the level shift circuit.
- The level shift circuit produces the differential output voltages and drives the two output power amplifiers. Since the differential gain of the output amplifiers is equal to $2 \times (1 + R4/R3)$, the output signal of the error amp is amplified by $(R2 / R1) \times 2 \times (1 + R4 / R3)$.
- If the total gain is insufficient, the input error amp can be used to increase the gain.
- The bias voltage is about half of the power supply voltage (V_M).

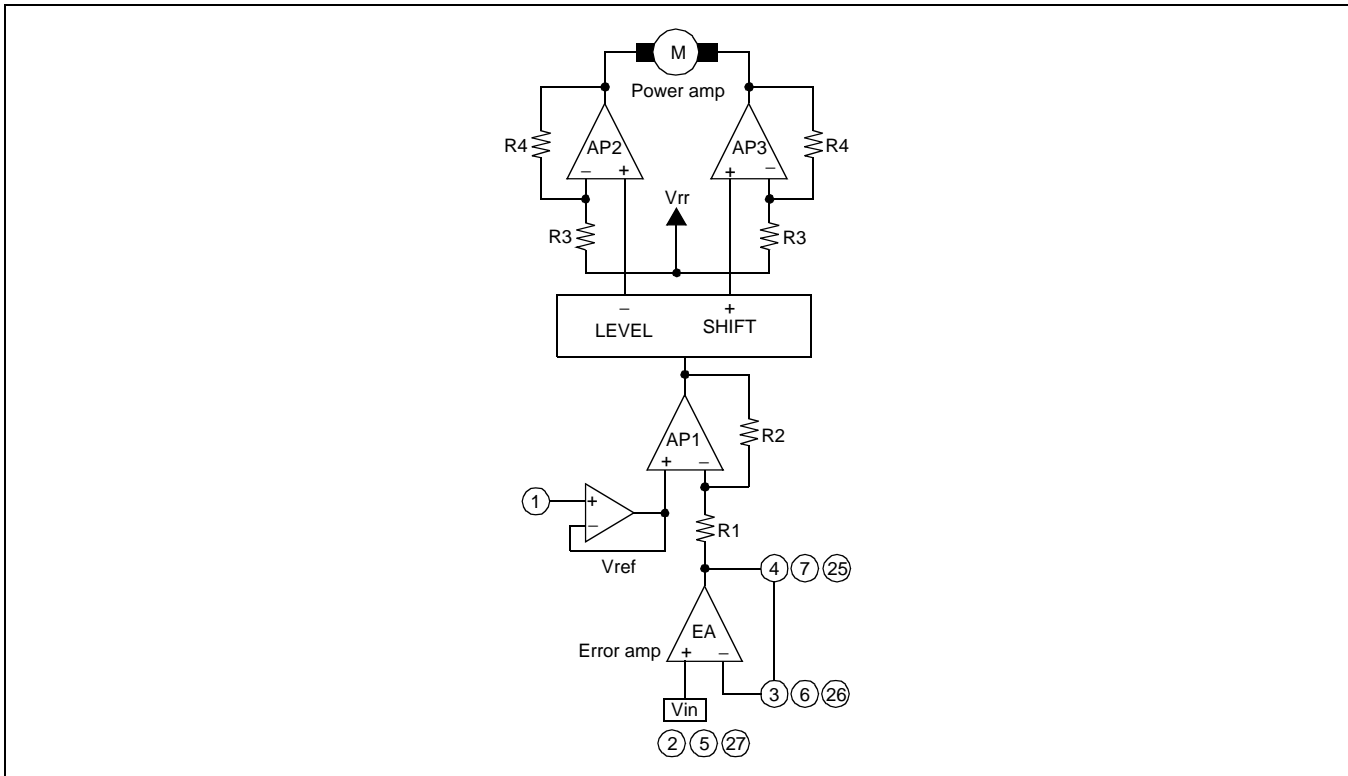
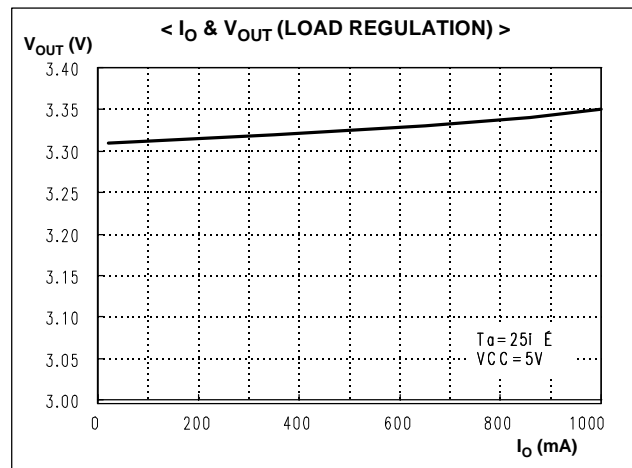
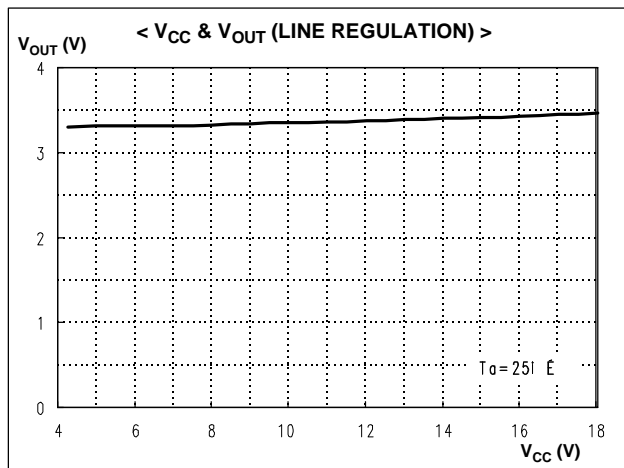
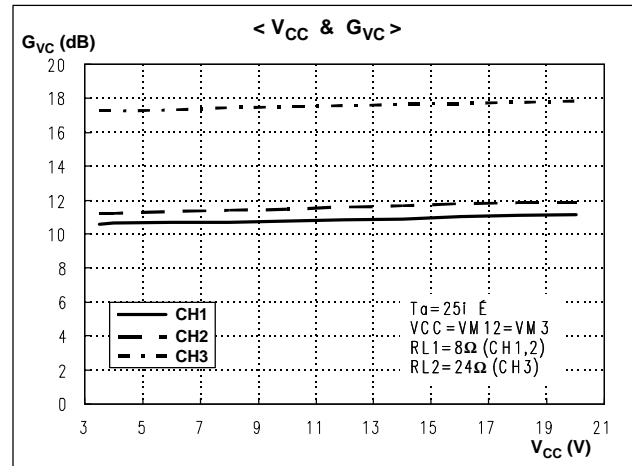
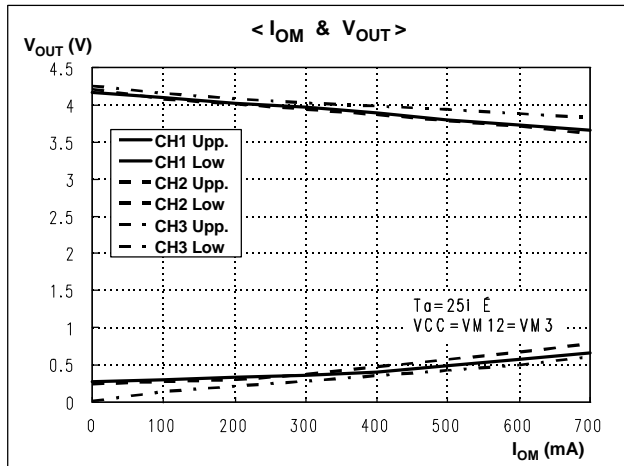
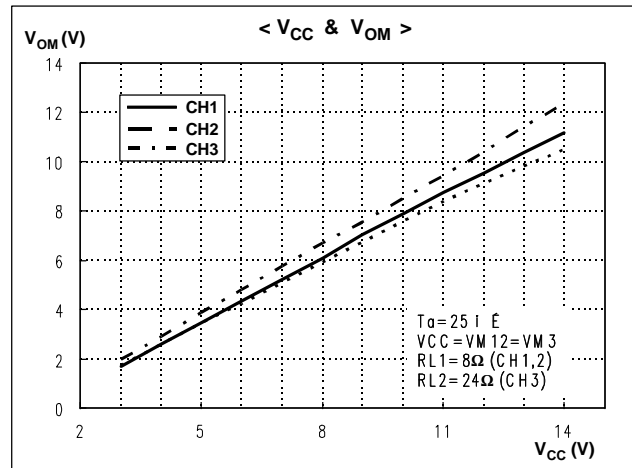
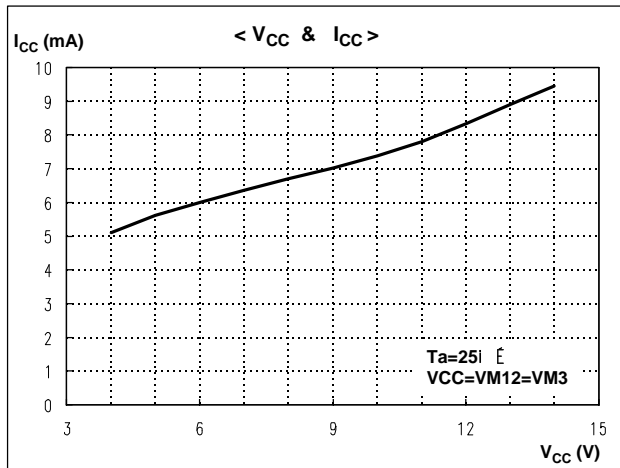
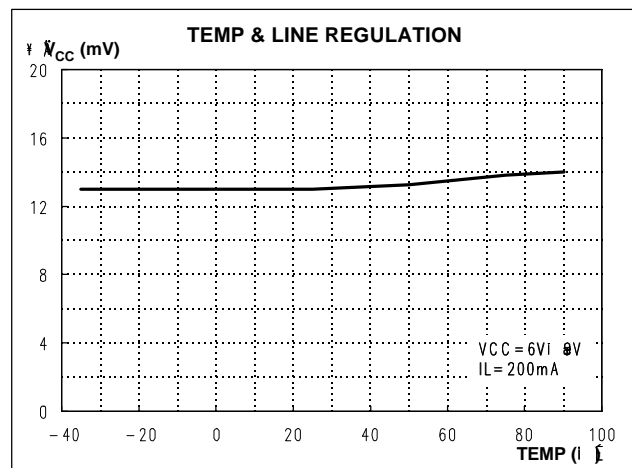
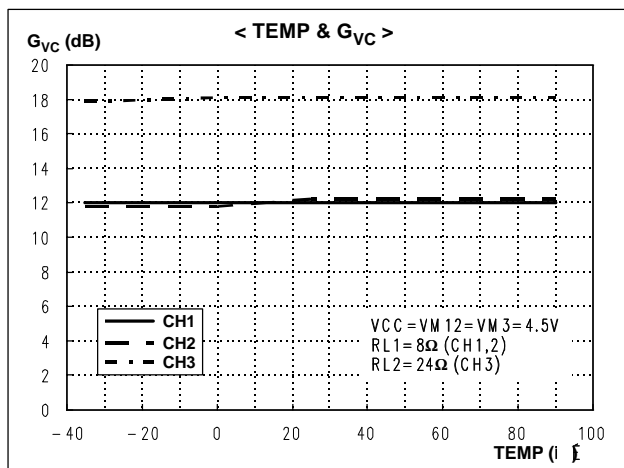
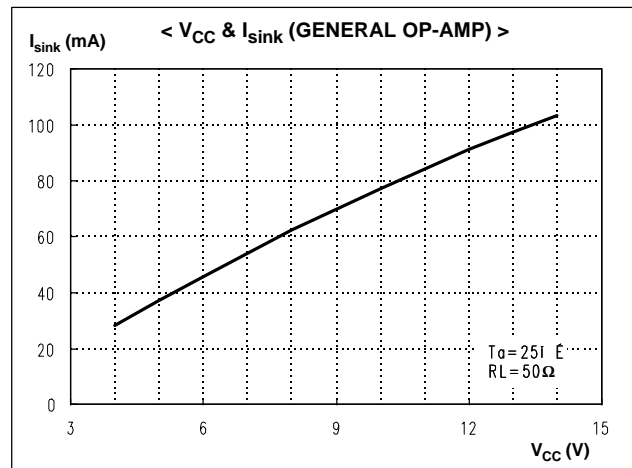
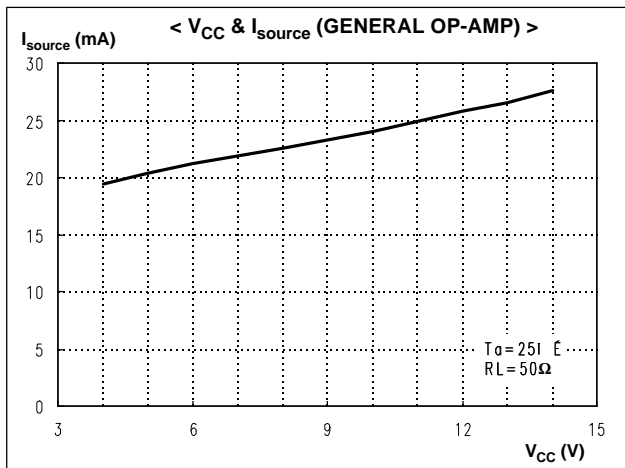
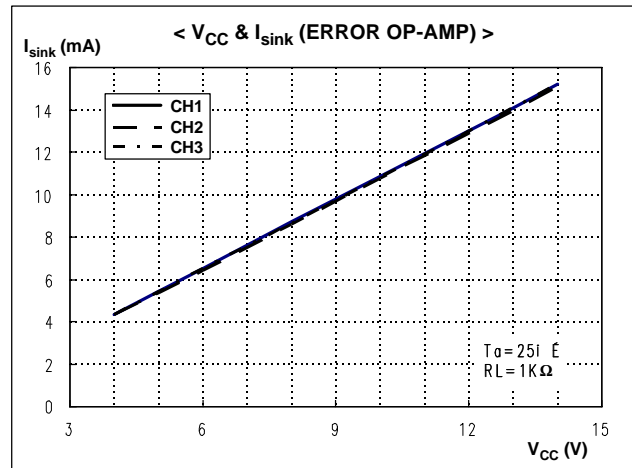
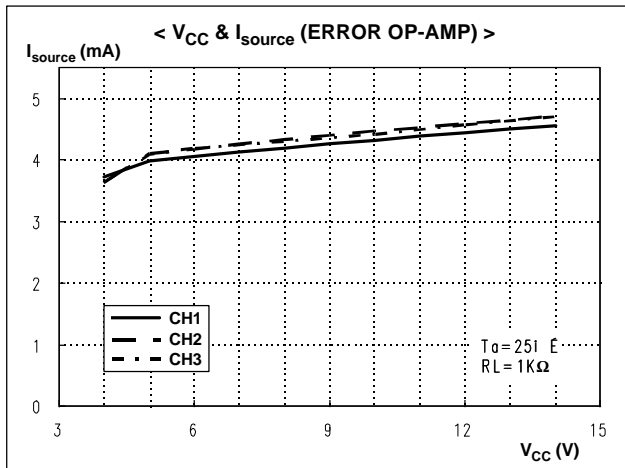

Figure 2. BTL drive circuit

ELECTRICAL CHARACTERISTICS CURVES



ELECTRICAL CHARACTERISTICS CURVES (Continued)



APPLICATION CIRCUIT 1

(Differential PWM control mode)

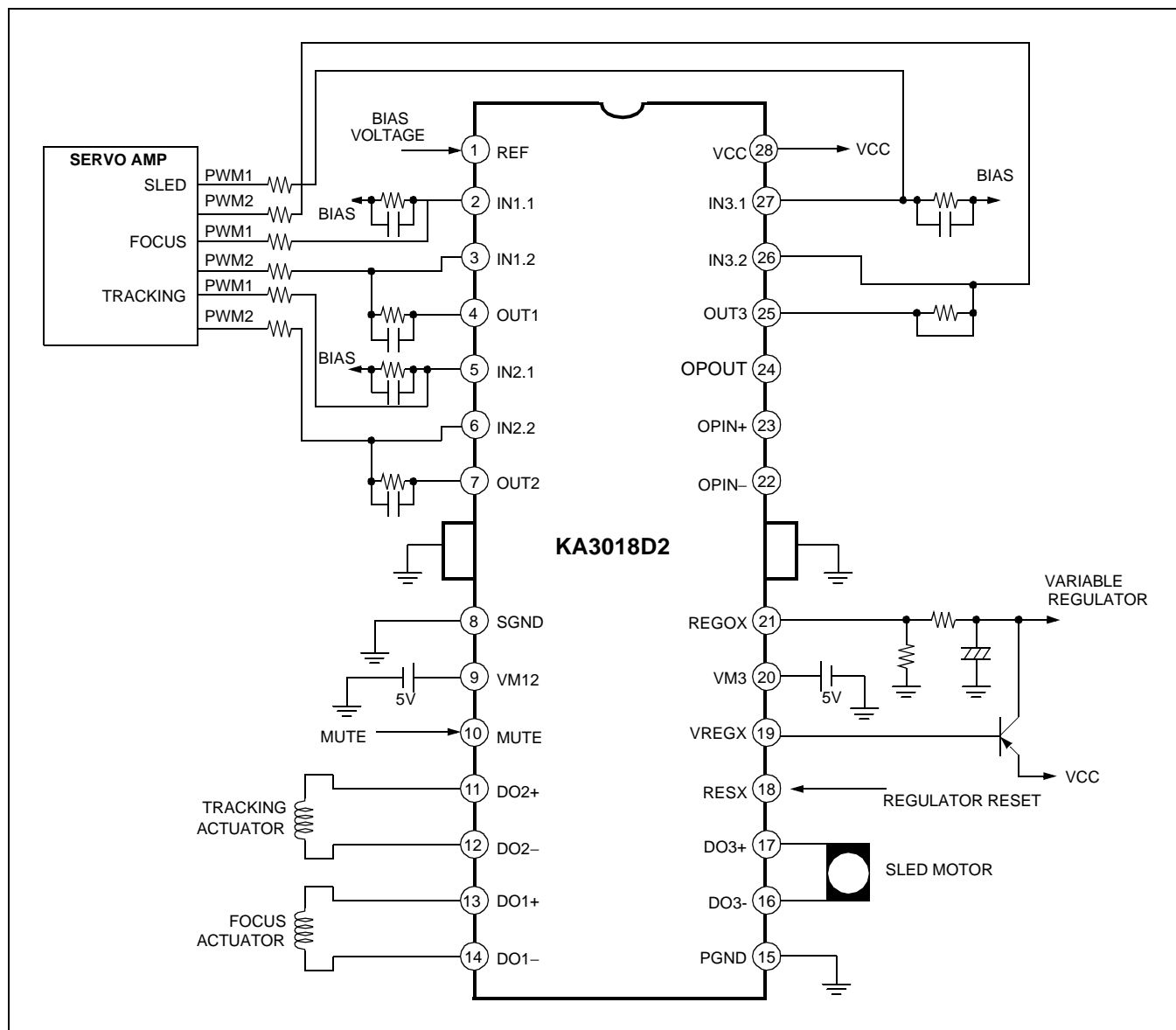

THERMAL SHUT DOWN CIRCUIT

The IC is broken down by the heat when overload condition continues for a long time. So, KA3018D2 has a thermal shut down circuit to prevent this case. At that time temperature of the IC rises over 175°C, the circuit is operating and protects the IC against breakdown.

APPLICATION CIRCUIT 2

(Voltage control mode)

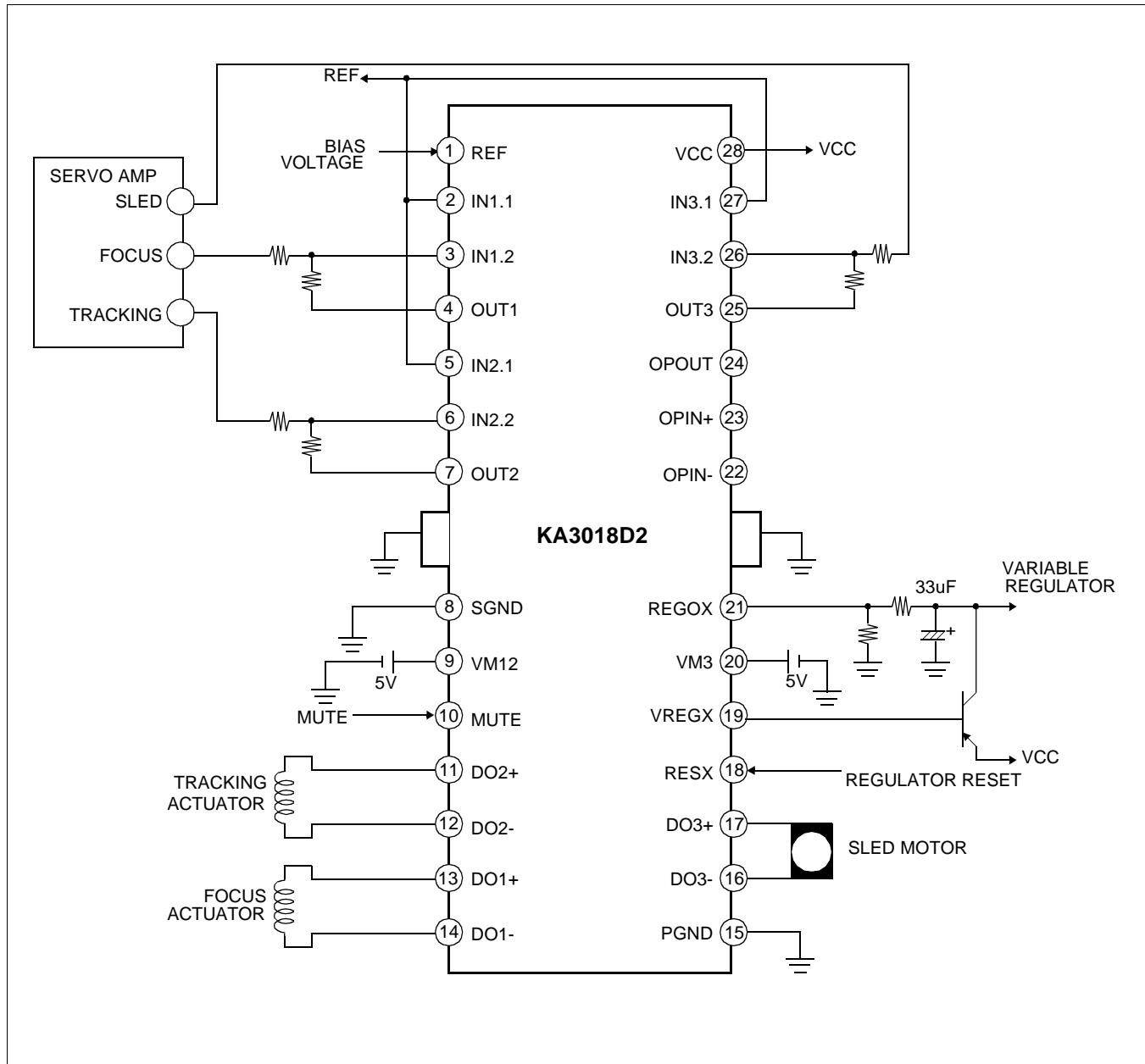

TRADEMARKS

The following are registered and unregistered trademarks Fairchild Semiconductor owns or is authorized to use and is not intended to be an exhaustive list of all such trademarks.

ACEx™	ISOPLANAR™
CoolFET™	MICROWIRE™
CROSSVOLT™	POP™
E ² CMOS™	PowerTrench™
FACT™	QS™
FACT Quiet Series™	Quiet Series™
FAST®	SuperSOT™-3
FASTr™	SuperSOT™-6
GTO™	SuperSOT™-8
HiSeC™	TinyLogic™

DISCLAIMER

FAIRCHILD SEMICONDUCTOR RESERVES THE RIGHT TO MAKE CHANGES WITHOUT FURTHER NOTICE TO ANY PRODUCTS HEREIN TO IMPROVE RELIABILITY, FUNCTION OR DESIGN. FAIRCHILD DOES NOT ASSUME ANY LIABILITY ARISING OUT OF THE APPLICATION OR USE OF ANY PRODUCT OR CIRCUIT DESCRIBED HEREIN; NEITHER DOES IT CONVEY ANY LICENSE UNDER ITS PATENT RIGHTS, NOR THE RIGHTS OF OTHERS.

LIFE SUPPORT POLICY

FAIRCHILD'S PRODUCTS ARE NOT AUTHORIZED FOR USE AS CRITICAL COMPONENTS IN LIFE SUPPORT DEVICES OR SYSTEMS WITHOUT THE EXPRESS WRITTEN APPROVAL OF FAIRCHILD SEMICONDUCTOR CORPORATION. As used herein:

1. Life support devices or systems are devices or systems which, (a) are intended for surgical implant into the body, or (b) support or sustain life, or (c) whose failure to perform when properly used in accordance with instructions for use provided in the labeling, can be reasonably expected to result in significant injury to the user.
2. A critical component is any component of a life support device or system whose failure to perform can be reasonably expected to cause the failure of the life support device or system, or to affect its safety or effectiveness.

PRODUCT STATUS DEFINITIONS

Definition of Terms

Datasheet Identification	Product Status	Definition
Advance Information	Formative or In Design	This datasheet contains the design specifications for product development. Specifications may change in any manner without notice.
Preliminary	First Production	This datasheet contains preliminary data, and supplementary data will be published at a later date. Fairchild Semiconductor reserves the right to make changes at any time without notice in order to improve design.
No Identification Needed	Full Production	This datasheet contains final specifications. Fairchild Semiconductor reserves the right to make changes at any time without notice in order to improve design.
Obsolete	Not In Production	This datasheet contains specifications on a product that has been discontinued by Fairchild semiconductor. The datasheet is printed for reference information only.