

4-CH MOTOR DRIVER

The KA3019D2 is a monolithic integrated circuit, suitable for a 1-ch (Forward.reverse) control DC motor driver and a 3-ch motor driver which drives the focus actuator, tracking actuator, and sled motor of a CD system.

FEATURES

- 3-Channel BTL driver
- 1-Channel forward-reverse control DC motor driver
- Built-in thermal shutdown circuit
- Built-in mute circuit
- Operating supply voltage: 4.5~5.5V
- Corresponds to 3.3V or 5V DSP

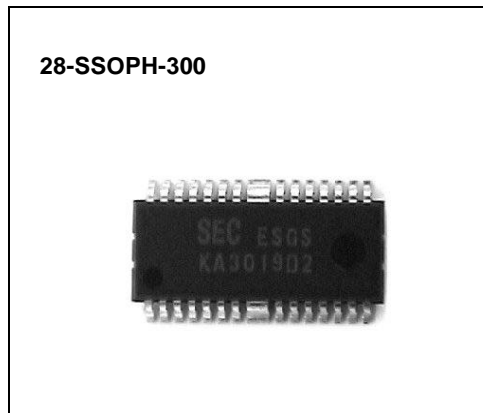

ORDERING INFORMATION

Device	Package	Operating Temperature
KA3019D2	28-SSOPH-300	-35°C ~ +85°C

BLOCK DIAGRAM

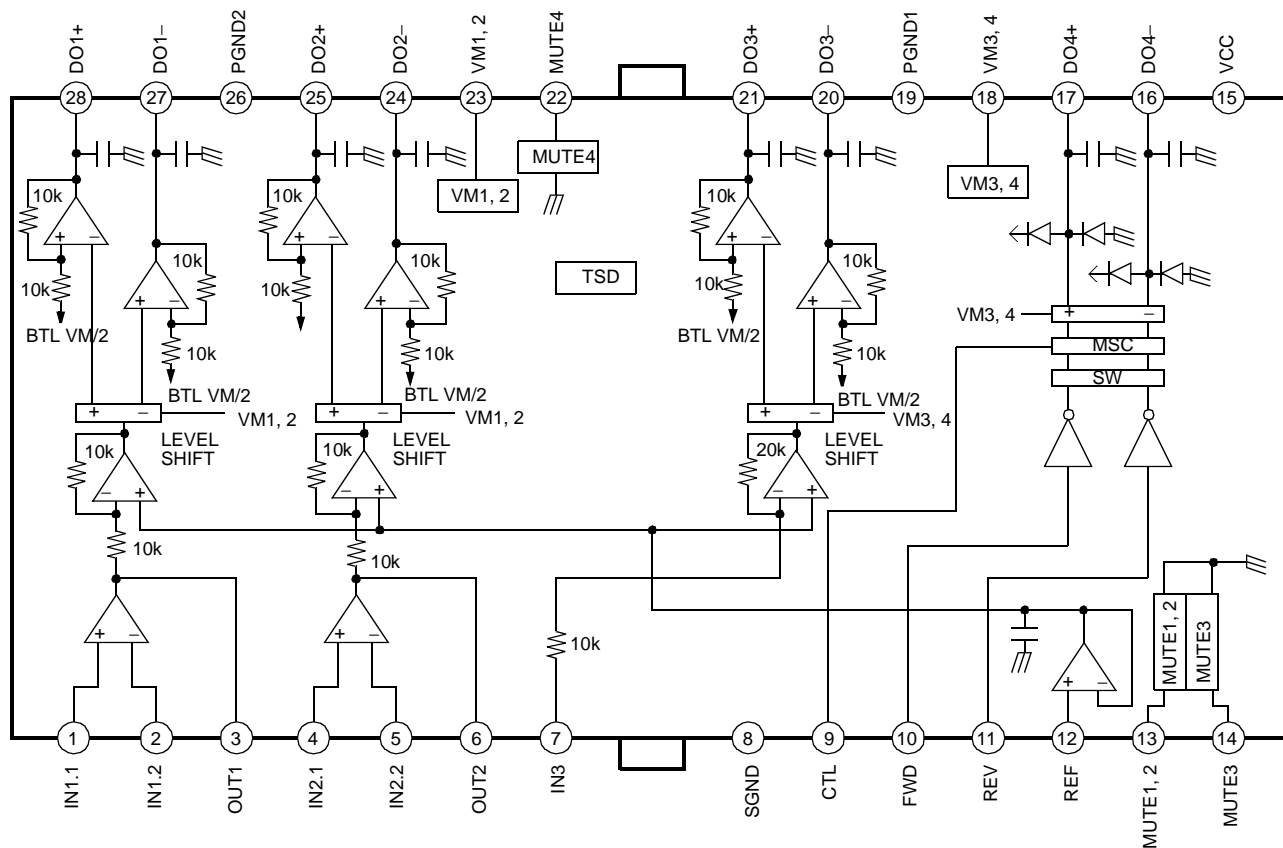

PIN CONFIGURATION

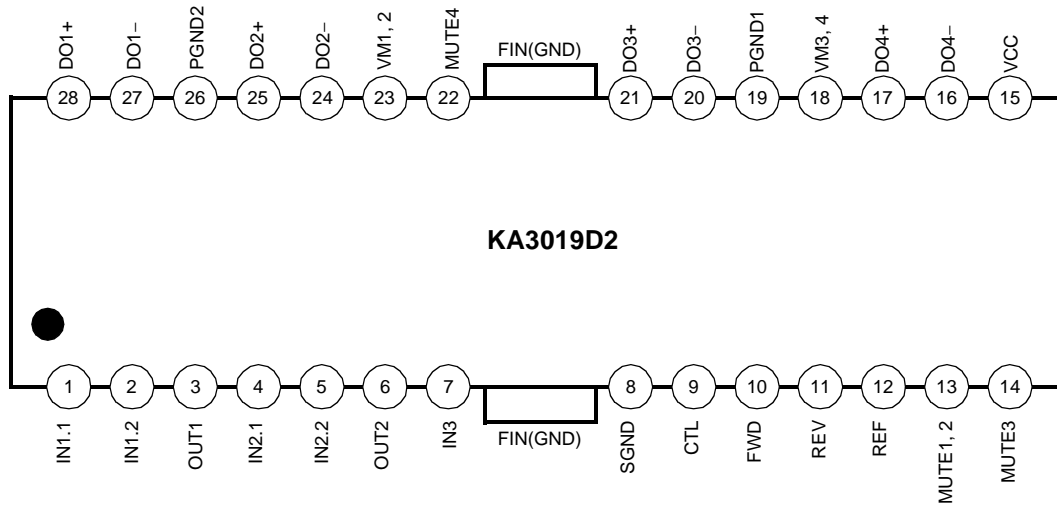

PIN DESCRIPTION

Pin No.	Symbol	I/O	Description	Pin No.	Symbol	I/O	Description
1	IN1.1	I	Op-amp CH1 input (+)	15	V _{CC}	-	Signal V _{CC}
2	IN1.2	I	Op-amp CH1 input (-)	16	DO4-	O	Drive4 output (-)
3	OUT1	O	Op-amp CH1 output	17	DO4+	O	Drive4 output (+)
4	IN2.1	I	Op-amp CH2 input (+)	18	VM3, 4	-	BTL CH3, 4 power V _{CC}
5	IN2.2	I	Op-amp CH2 input (-)	19	PGND1	-	CH3, 4 power ground
6	OUT2	O	Op-amp CH2 output	20	DO3-	O	Drive3 output (-)
7	IN3	I	Op-amp CH3 Input	21	DO3+	O	Drive3 output (+)
8	SGND	-	Signal ground	22	MUTE4	-	CH4 mute
9	CTL	I	CH4 motor speed control	23	VM1, 2	-	BTL CH1, 2 power V _{CC}
10	FWD	I	CH4 forward	24	DO2-	O	Drive2 output (-)
11	REV	I	CH4 reverse	25	DO2+	O	Drive2 output (+)
12	REF	I	Bias voltage input	26	PGND2	-	CH1, 2 power ground
13	MUTE1, 2	I	CH1, 2 mute	27	DO1-	O	Drive1 output (-)
14	MUTE3	I	CH3 mute	28	DO1+	O	Drive1 output (+)

EQUIVALENT CIRCUITS

Mute input	Power output
CH3 level shift input	Signal reference input
Error amp input	Loading control input
Error amp output	Loading logic input

ABSOLUTE MAXIMUM RATINGS (Ta=25°C)

Characteristics	Symbol	Value	Unit
Maximum supply voltage	V_{CCMAX}	7	V
Power dissipation	P_D	@1.4	W
Operating temperature range	T_{OPR}	-35 ~ +85	°C
Storage temperature range	T_{STG}	-55 ~ +150	°C

@:

1. When mounted on a 76.2mm × 114mm × 1.57mm PCB (Phenolic resin material).
2. Power dissipation reduces 11.2mW / °C for using above Ta = 25°C
3. Do not exceed Pd and SOA (Safe operating area).

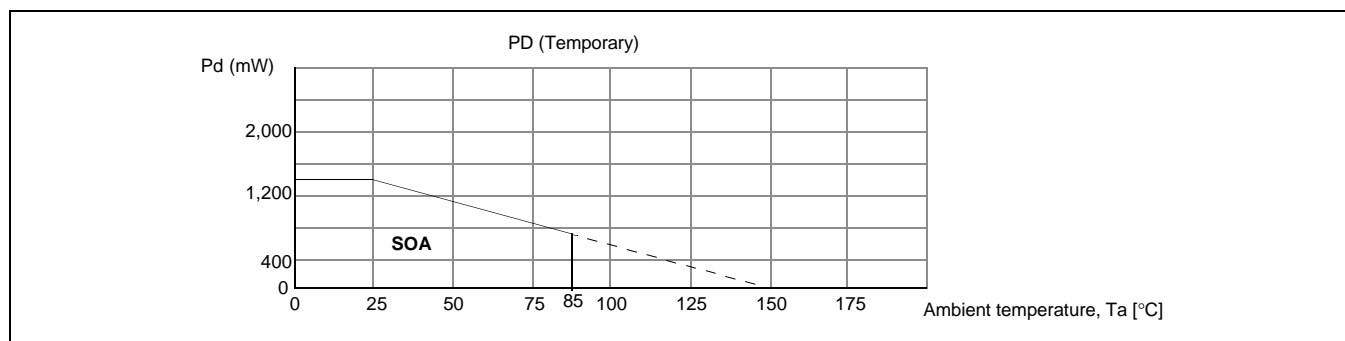
**RECOMMENDED OPERATING CONDITIONS**

Characteristics	Symbol	Min.	Typ.	Max.	Unit
Supply voltage	V_{CC}	4.5	–	5.5	V

ELECTRICAL CHARACTERISTICS

(Unless otherwise specified, $T_a=25^\circ\text{C}$, $V_{CC}=VM12=VM3$, $4=5\text{V}$)

Characteristics	Symbol	Conditions	Min.	Typ.	Max.	Unit
Quiescent current	I_{CC}	$V_{IN}=0\text{V}$	–	8	12	mA
CH Mute on current	I_{MUTECH}	Pin13, Pin14, Pin22=GND	–	1	3	mA
CH Mute on voltage	V_{MONCH}	Pin13, Pin14, Pin22=Variation	–	–	0.5	V
CH Mute off voltage	V_{MOFFCH}	Pin13, Pin14, Pin22=Variation	2	–	–	V
DRIVE PART						
Input offset voltage	V_{IO}	–	–20	–	+20	mV
Output offset voltage	V_{OO}	$V_{IN}=2.5\text{V}$	–40	–	+40	mV
Maximum output voltage 1	V_{OM1}	$R_L=8\Omega$ (CH1, 2)	2.7	3.4	–	V
Maximum output voltage 2	V_{OM2}	$R_L=24\Omega$ (CH3)	3	3.8	–	V
Close loop voltage gain 1	G_{VC1}	$f=1\text{kHz}$, $V_{IN}=0.1V_{RMS}$ (CH1, 2)	10.5	12	13.5	dB
Close loop voltage gain 2	G_{VC2}	$f=1\text{kHz}$, $V_{IN}=0.1V_{RMS}$ (CH3)	16	18	20	dB
Ripple rejection ratio	RR	$V_{IN}=0.1V_{RMS}$, $f=120\text{Hz}$	–	60	–	dB
Slew rate	SR	$V_O=2\text{Vp-p}$, $f=120\text{kHz}$	–	0.8	–	V/ μs
ERROR OP AMP PART						
Input offset voltage	V_{OFOP}	–	–10	–	+10	mV
Input bias current	I_{BOP}	–	–	–	300	nA
High level output voltage	V_{OHOP}		4.5	4.8	–	V
Low level output voltage	V_{OLOP}		–	0.2	0.5	V
Output sink current	I_{SINK}	$R_L=1\text{k}\Omega$	2	4	–	mA
Output source current	I_{SOURCE}	$R_L=1\text{k}\Omega$	2	4	–	mA
Open loop voltage gain	G_{VO}	$V_{IN}=-75\text{dB}$, $f=1\text{kHz}$	–	75	–	dB
Ripple rejection ratio	RR_{OP}	$V_{IN}=-20\text{dB}$, $f=120\text{Hz}$	–	65	–	dB
Slew rate	SR_{OP}	$f=120\text{kHz}$, 2Vp-p	–	1	–	V/ μs
Common mode rejection ratio	CMRR	$V_{IN}=-20\text{dB}$, $f=1\text{kHz}$	–	80	–	dB
Common mode input range	V_{ICM}		–0.3	–	4.5	V
TRAY DRIVE PART ($V_{CC} = VM3$, $4 = 5\text{V}$, $R_L = 45\Omega$)						
Input high level voltage	V_{IH}	–	2	–	–	V
Input low level voltage	V_{IL}	–	–	–	0.5	V
Output voltage	V_O	$V_{CTL}=3.5\text{V}$	2.8	3.5	4.2	V
Output load regulation	ΔV_{RL}	–	–	300	700	mV
Output offset voltage 1	V_{OO1}	$V_{IN}=5\text{V}$, 5V	–10	–	+10	mV
Output offset voltage 2	V_{OO2}	$V_{IN}=0\text{V}$, 0V	–10	–	+10	mV

APPLICATION INFORMATION

1. REFERENCE INPUT

Pin 12 (REF) is a reference Input pin.

- Reference input
The applied voltage at the reference input pin must be between 2V and 6.5V, when $V_{CC}=8.5V$.

2. SEPARATED CHANNEL MUTE FUNCTION

These pins are used for individual channel mute operation.

- When the mute pins (pin13, 14 and 22) are Low level, the mute circuits are enabled and the output circuits are muted.
- When the voltage of the mute pins (pin13, 14 and 22) are High level, the mute circuits are disabled and the output circuits operate normally.
- If the chip temperature rises above 175°C, then the thermal shutdown (TSD) circuit is activated and the output circuits are muted.
 - Mute1, 2 (pin 13)-CH1, 2 mute control input pin.
 - Mute3 (pin 14)-CH3 mute control input pin.
 - Mute4(pin22) - CH4 mute control input pin.

3. PROTECTION FUNCTION

Thermal Shutdown (TSD)

- If the chip temperature rises above 175°C the thermal shutdown (TSD) circuit is activated and the output circuit is in the Mute state, that is Off state.
The TSD circuit has a temperature hysteresis of 25°C.

4. FOCUS, TRACKING ACTUATOR, SLED MOTOR DRIVE PART

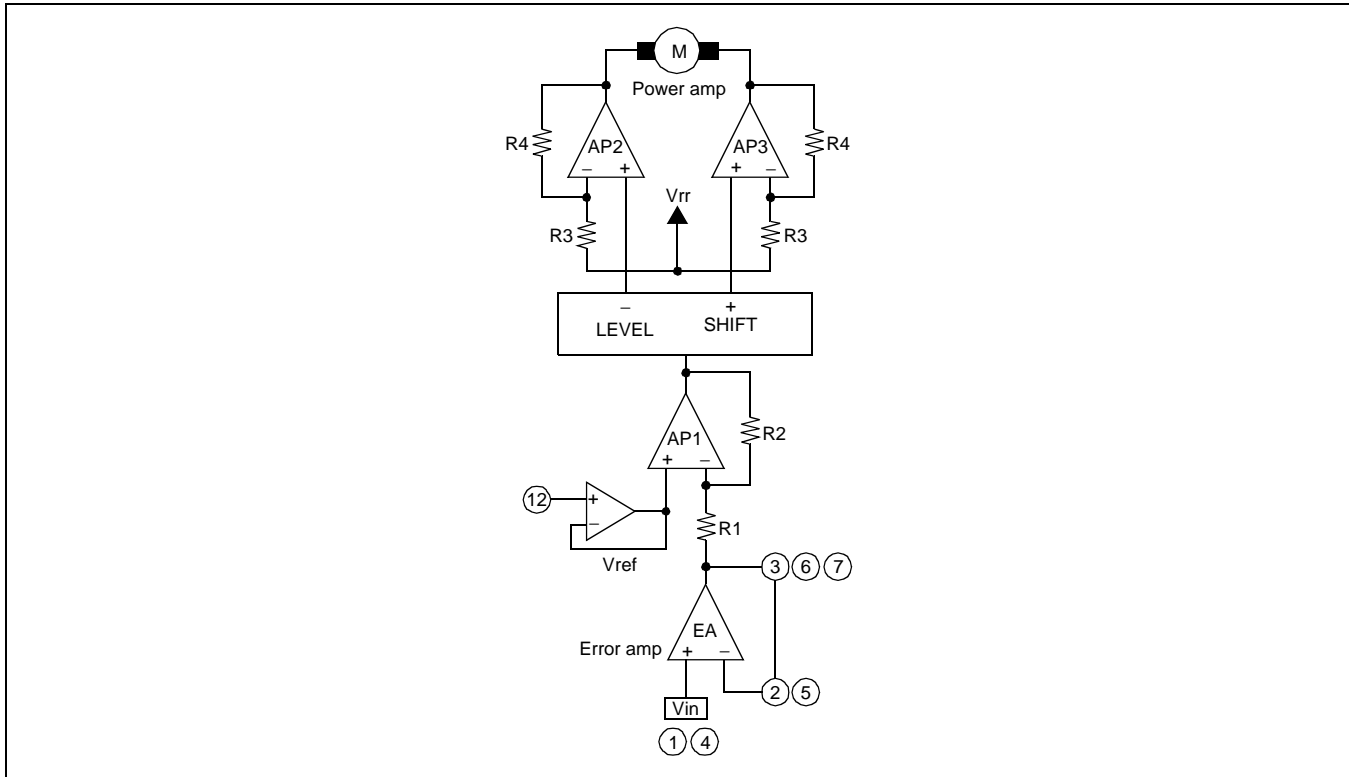

- The reference voltage REF is given externally through pin 12.
- The error amp output signal is amplified by R_2 / R_1 times and then fed to the level shift circuit.
- The level shift circuit produces the differential output voltages and drives the two output power amplifiers. Since the differential gain of the output amplifiers is equal to $2 \times (1 + R_4 / R_3)$, the output signal of the error amp is amplified by $(R_2 / R_1) \times 2 \times (1 + R_4 / R_3)$.
- If the total gain is insufficient, the input error amp can be used to increase the gain.
- The bias voltage (V_{rr}) is about a half of the supply voltage (V_M).

5. TRAY, CHANGE MOTOR DRIVE PART

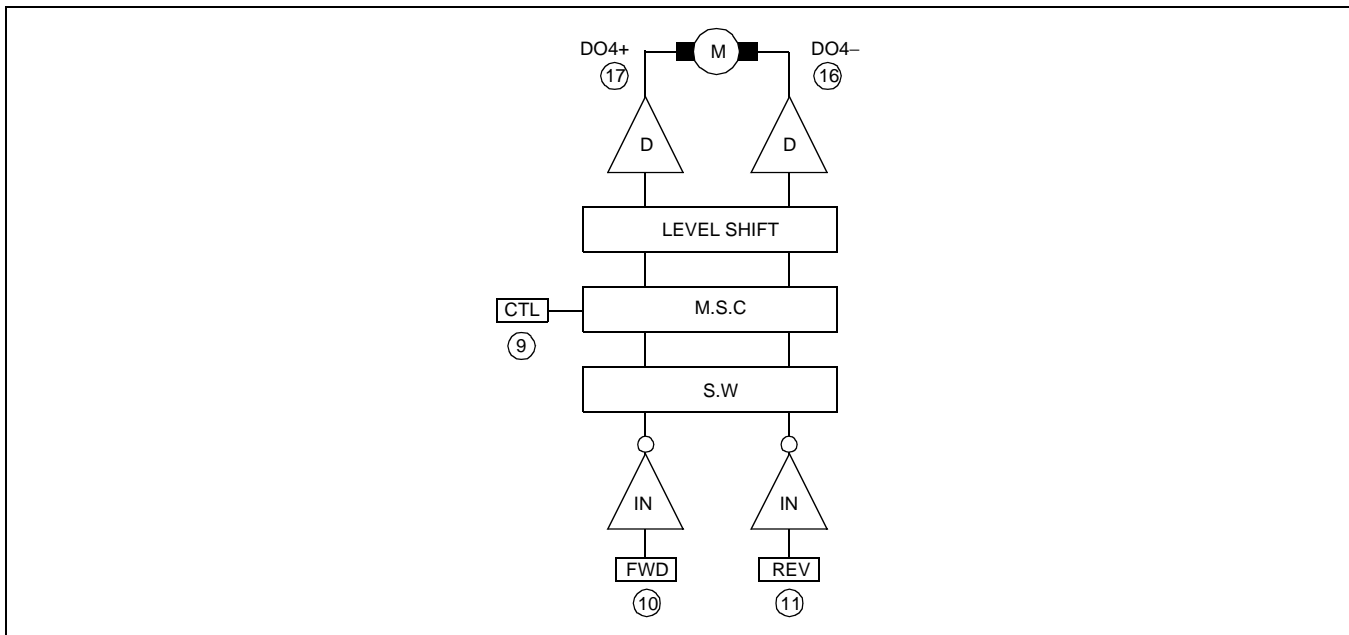

- Rotational direction control
The forward and reverse rotational direction is controlled by FWD (pin 10) and REV (pin 11) inputs. Conditions are as follows.

Input		Output		
FWD	REV	DO4+	DO4-	State
H	H	Vr	Vr	Brake
H	L	H	L	Forward
L	H	L	H	Reverse
L	L	Vr	Vr	Brake

- Motor speed control
 - The motor speed is proportional to the difference voltage between the pin17 (DO4+) and the pin16 (DO4-).
 - By applying the voltage to the pin9 of CTL, the motor speed can be controlled and it is linearly proportional to the applied control voltage.
 - When both VM3, 4 and V_{CC} are 5V, and the applied control voltage is higher than 4V, the motor speed is not proportional to the control voltage but the motor speed becomes constant.
 - If the pin9 is opened, the motor torque becomes maximum.
 - The maximum output swing is 3.8V, when VM3, 4 and V_{CC} are 5V.

ELECTRICAL CHARACTERISTICS CURVES

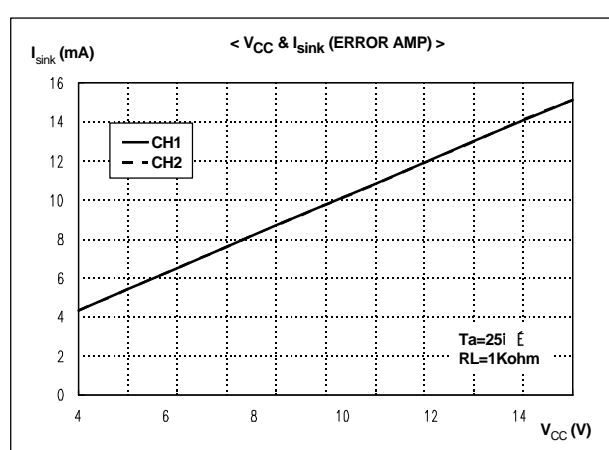
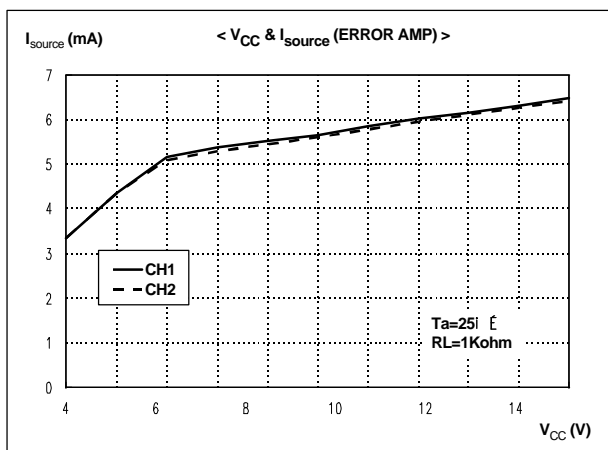
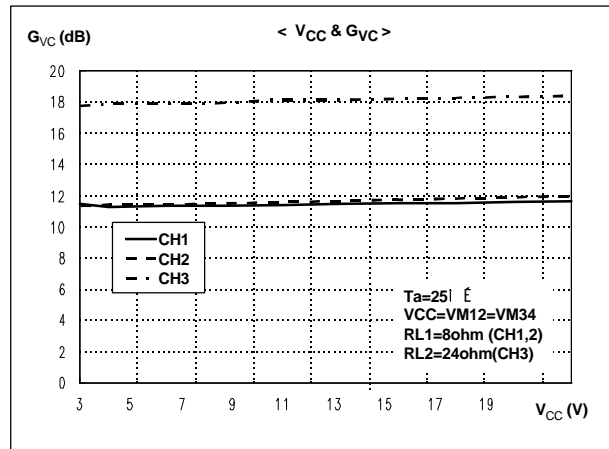
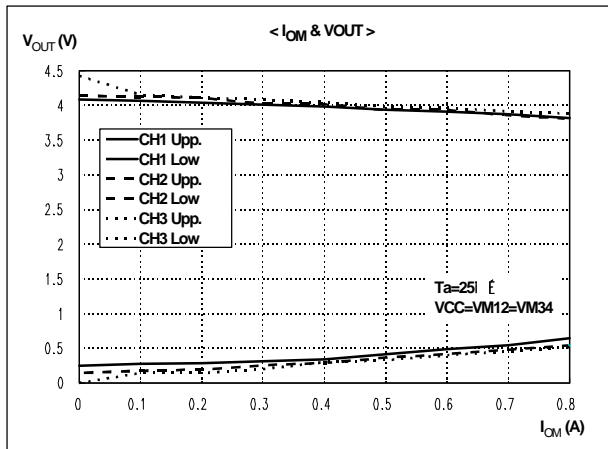
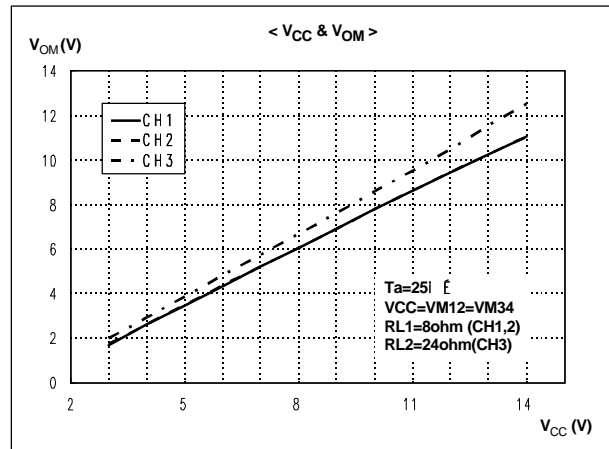
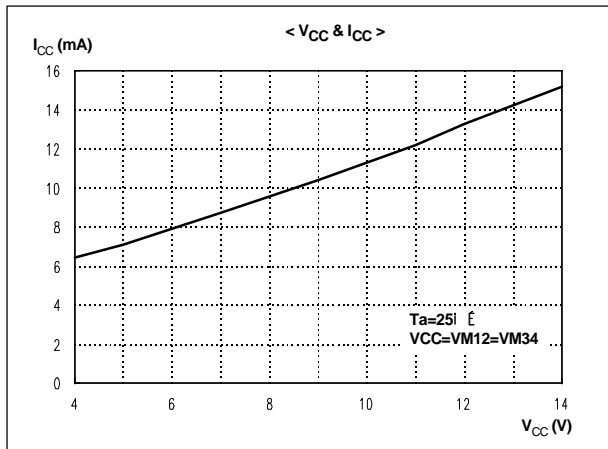

ELECTRICAL CHARACTERISTICS CURVES (Continued)

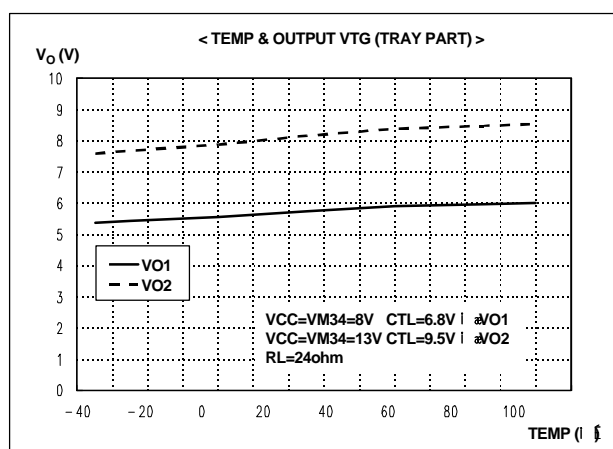
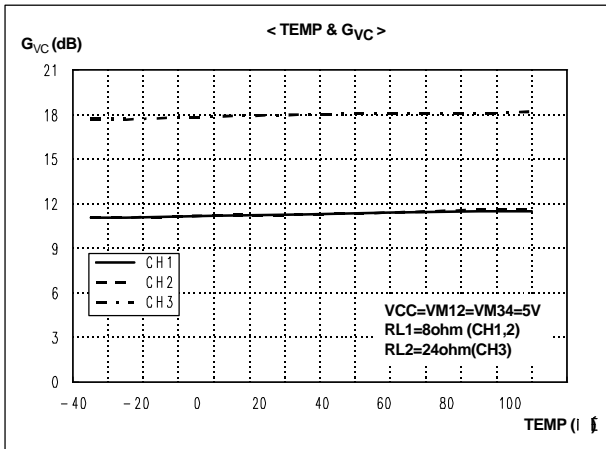
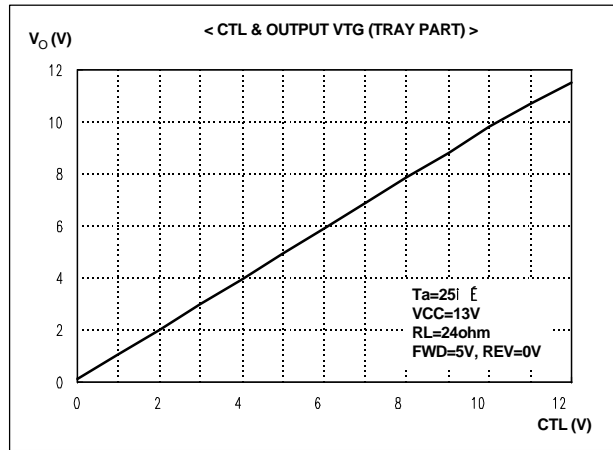
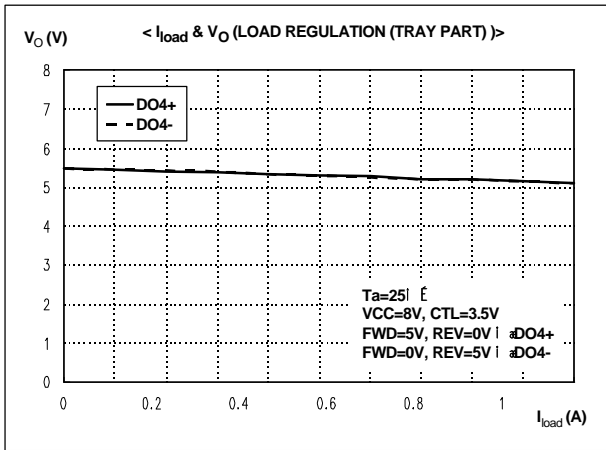

APPLICATION CIRCUIT 1

(Differential PWM control mode)

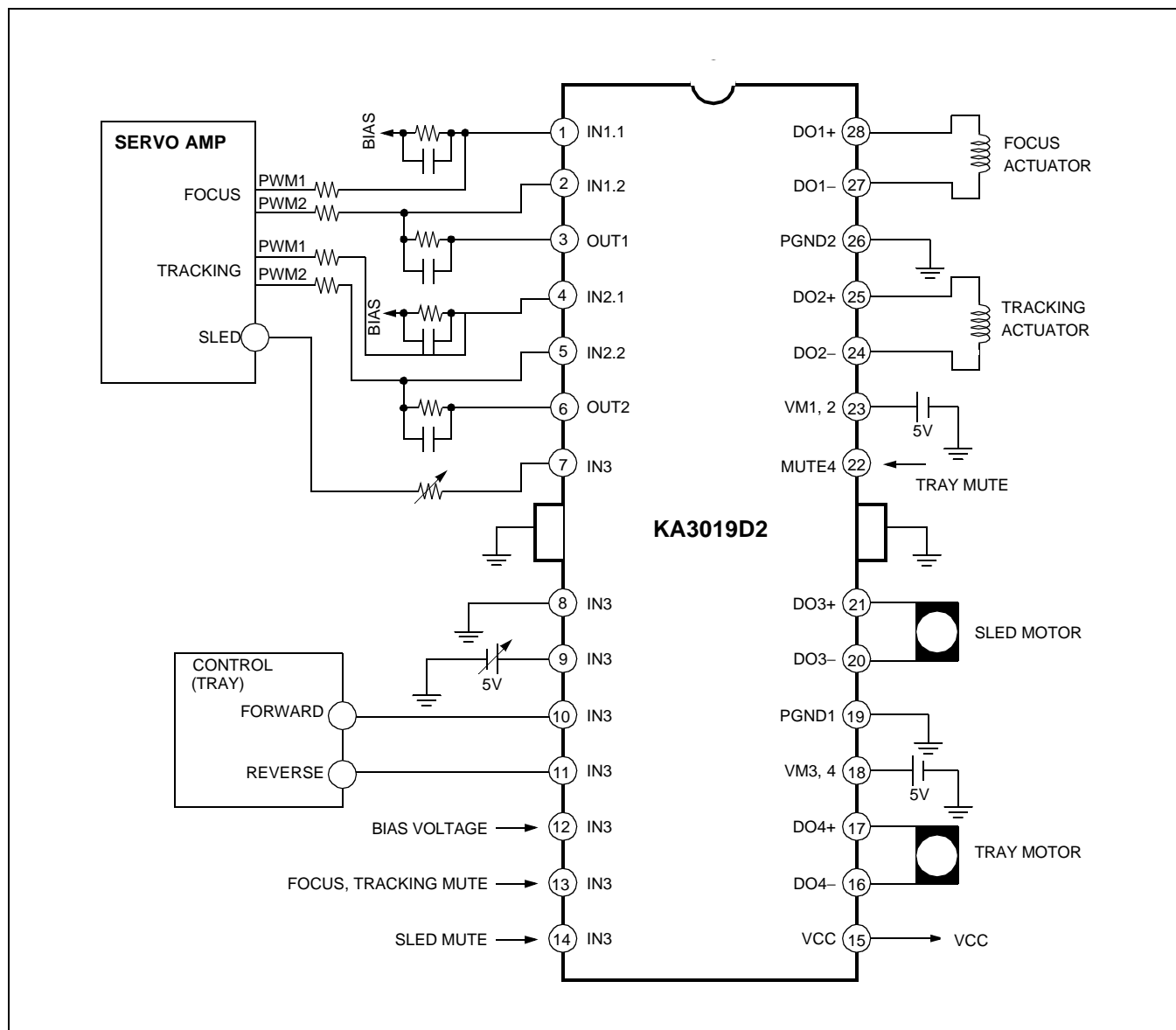

THERMAL SHUT DOWN CIRCUIT

The IC is broken down by the heat when overload condition continues for a long time. So, KA3019D2 has a thermal shut down circuit to prevent this case. At that time temperature of the IC rises over 175°C, the circuit is operating and protects the IC against breakdown.

APPLICATION CIRCUIT 2

(Voltage control mode)

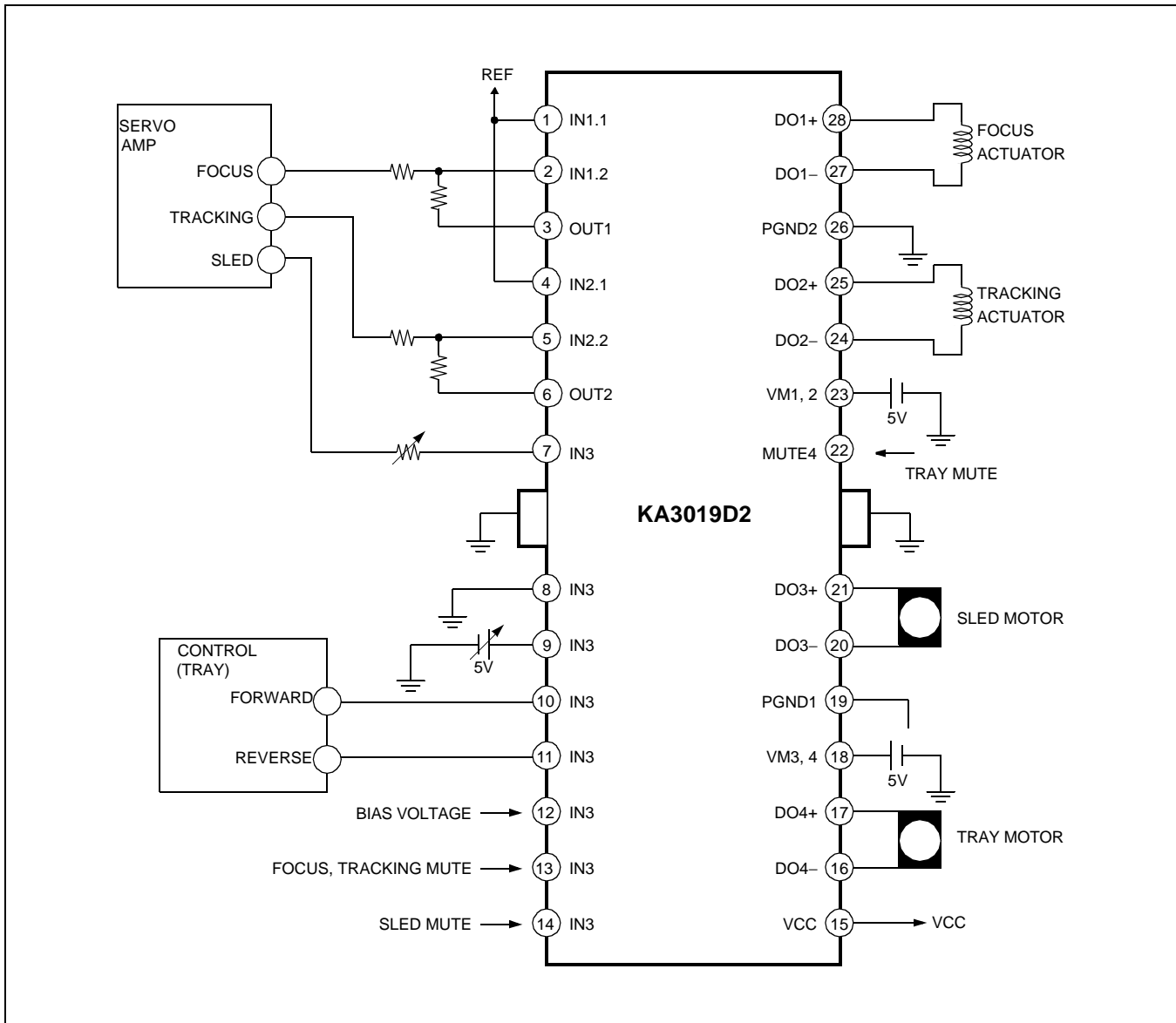

TRADEMARKS

The following are registered and unregistered trademarks Fairchild Semiconductor owns or is authorized to use and is not intended to be an exhaustive list of all such trademarks.

ACEx™	ISOPLANAR™
CoolFET™	MICROWIRE™
CROSSVOLT™	POP™
E ² CMOS™	PowerTrench™
FACT™	QS™
FACT Quiet Series™	Quiet Series™
FAST®	SuperSOT™-3
FASTr™	SuperSOT™-6
GTO™	SuperSOT™-8
HiSeC™	TinyLogic™

DISCLAIMER

FAIRCHILD SEMICONDUCTOR RESERVES THE RIGHT TO MAKE CHANGES WITHOUT FURTHER NOTICE TO ANY PRODUCTS HEREIN TO IMPROVE RELIABILITY, FUNCTION OR DESIGN. FAIRCHILD DOES NOT ASSUME ANY LIABILITY ARISING OUT OF THE APPLICATION OR USE OF ANY PRODUCT OR CIRCUIT DESCRIBED HEREIN; NEITHER DOES IT CONVEY ANY LICENSE UNDER ITS PATENT RIGHTS, NOR THE RIGHTS OF OTHERS.

LIFE SUPPORT POLICY

FAIRCHILD'S PRODUCTS ARE NOT AUTHORIZED FOR USE AS CRITICAL COMPONENTS IN LIFE SUPPORT DEVICES OR SYSTEMS WITHOUT THE EXPRESS WRITTEN APPROVAL OF FAIRCHILD SEMICONDUCTOR CORPORATION. As used herein:

1. Life support devices or systems are devices or systems which, (a) are intended for surgical implant into the body, or (b) support or sustain life, or (c) whose failure to perform when properly used in accordance with instructions for use provided in the labeling, can be reasonably expected to result in significant injury to the user.
2. A critical component is any component of a life support device or system whose failure to perform can be reasonably expected to cause the failure of the life support device or system, or to affect its safety or effectiveness.

PRODUCT STATUS DEFINITIONS

Definition of Terms

Datasheet Identification	Product Status	Definition
Advance Information	Formative or In Design	This datasheet contains the design specifications for product development. Specifications may change in any manner without notice.
Preliminary	First Production	This datasheet contains preliminary data, and supplementary data will be published at a later date. Fairchild Semiconductor reserves the right to make changes at any time without notice in order to improve design.
No Identification Needed	Full Production	This datasheet contains final specifications. Fairchild Semiconductor reserves the right to make changes at any time without notice in order to improve design.
Obsolete	Not In Production	This datasheet contains specifications on a product that has been discontinued by Fairchild semiconductor. The datasheet is printed for reference information only.