

4-CH MOTOR DRIVER

The KA3022D is a monolithic integrated circuit, suitable for a 1-ch (forward.reverse) control DC motor driver and a 3-ch motor driver which drives the focus actuator, tracking actuator, and sled motor of a CD system.

FEATURES

- 3-Channel BTL driver
- 1-Channel forward-Reverse control DC motor driver
- Built-in thermal shutdown circuit
- Built-in mute circuit
- Operating supply voltage: 4.5~13.2V
- Corresponds to 3.3V or 5V DSP

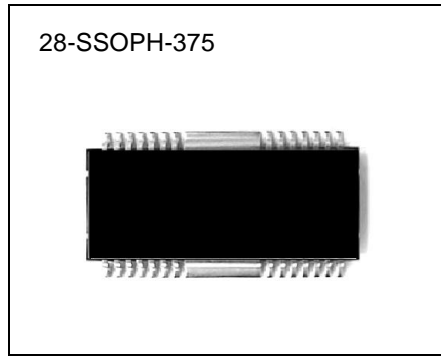

ORDERING INFORMATION

Device	Package	Operating Temperature
KA3022D	28-SSOPH-375	-35 °C ~ 85 °C

BLOCK DIAGRAM

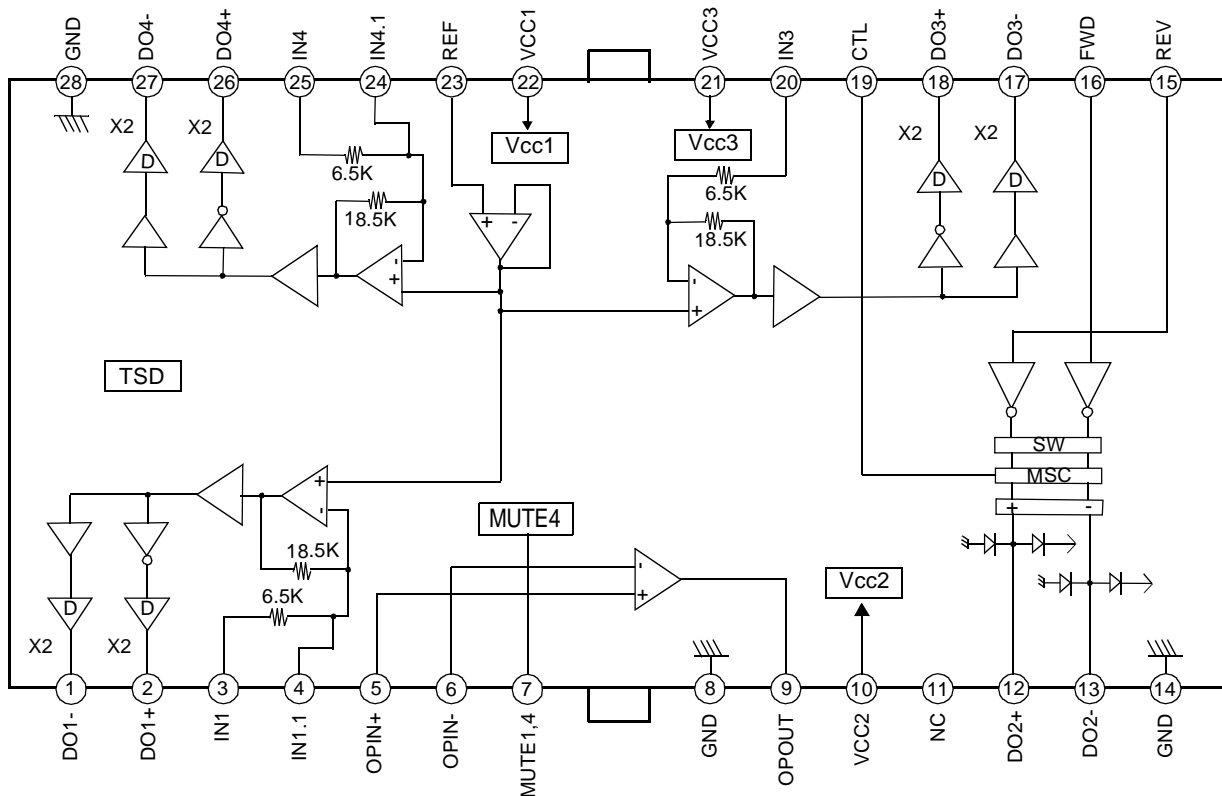

PIN CONFIGURATION

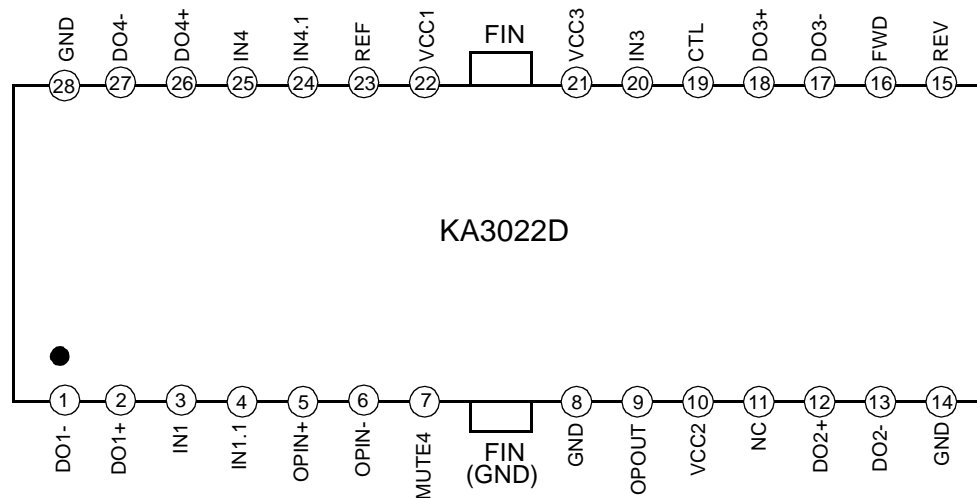

PIN DESCRIPTION

Pin No.	Symbol	I/O	Description	Pin No.	Symbol	I/O	Description
1	DO1-	O	Drive1 Output (-)	15	REV	I	CH2 Reverse
2	DO1+	O	Drive1 Output (+)	16	FWD	I	CH2 Forward
3	IN1	I	Drive1 Input	17	DO3-	O	Drive3 Output (-)
4	IN1.1	I	Drive1 Input, gain adjust.	18	DO3+	O	Drive3 Output (+)
5	OPIN+	I	OP-AMP Input (+)	19	CTL	I	CH2 Motor Speed Control
6	OPIN-	I	OP-AMP Input (-)	20	IN3	I	CH3 Input
7	MUTE1,4	I	CH4 Mute	21	VCC3	I	Power Supply for CH3
8	GND	-	Ground	22	VCC1	I	Power Supply for CH1
9	OPOUT	O	OP-Amp Output	23	REF	I	Bias Voltage Input
10	VCC2	I	Power Supply for CH2	24	IN4.1	I	Drive4 Input, gain adjust.
11	NC	-	No Connection	25	IN4	I	Drive4 Input
12	DO2+	O	Drive2 Output (+)	26	DO4+	O	Drive4 Output (+)
13	DO2-	O	Drive2 Output (-)	27	DO4-	O	Drive4 Output (-)
14	GND	-	Ground	28	GND	-	Ground

EQUIVALENT CIRCUITS

MUTE INPUT	POWER OUTPUT
SIGNAL REFERENCE INPUT	LOADING CONTROL INPUT
LOADING LOGIC INPUT	

ABSOLUTE MAXIMUM RATINGS (TA = 25 °C)

Characteristics	Symbol	Value	Unit
Maximum supply voltage	V_{CCmax}	15	V
Power dissipation	P_d	@1.7	W
Operating temperature range	T_{opr}	-35 ~ +85	°C
Storage temperature range	T_{stg}	-55 ~ +150	°C

- @ 1. When mounted on a 50mm × 50mm × 1mm PCB (Phenolic resin material).
 2. Power dissipation reduces 13.6mW/°C for using above Ta = 25°C
 3. Do not exceed PD and SOA(Safe operating area).

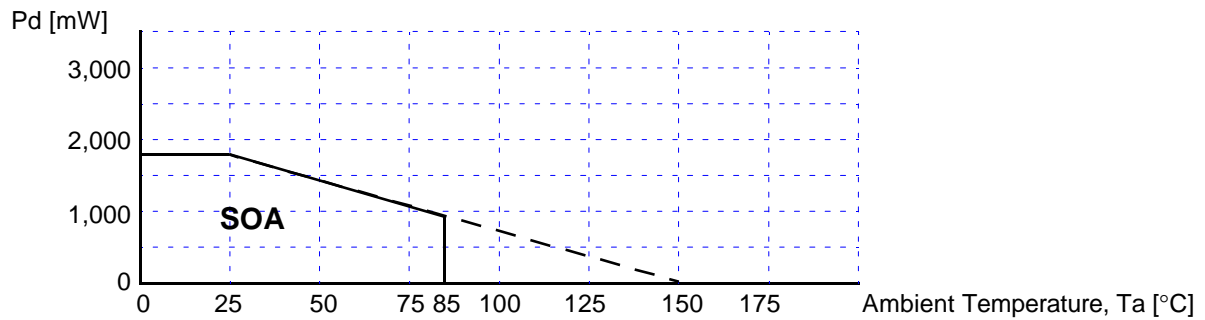

RECOMMENDED OPERATING CONDITIONS

Characteristics	Symbol	Value			Unit
		Min	Typ	Max	
Supply Voltage	Vcc	4.5	-	13.2	V

ELECTRICAL CHARACTERISTICS(Unless otherwise specified, $T_a = 25\text{ }^\circ\text{C}$, $V_{CC} = V_{M12} = V_{M3,4} = 5\text{V}$)

Characteristics	Symbol	Conditions	Spec			Unit
			Min	Typ	Max	
Quiescent Current	I_{CC}	$V_{in} = 0\text{V}$	-	9.3	15	mA
Mute On Current	I_{mute}	Mute Pin = V_{CC}	-	7.9	9.5	mA
Mute On Voltage	V_{mon}		2.0	-	-	V
Mute Off Voltage	V_{moff}		-	-	0.5	V
DRIVE PART						
Output Offset Voltage	V_{oo}	$V_{in} = 2.5\text{V}$	-50	-	+50	mV
Maximum Output Voltage1	V_{om1}	$V_{CC} = 8\text{V}$, $R_L = 8\Omega$	5.4	6.0	-	V
Closed Loop Voltage Gain	G_{vc}	$f = 1\text{KHz}$, $V_{in} = 0.1\text{Vrms}$ (CH1,3, 4)	19.5	21.0	22.5	dB
Ripple Rejection Ratio	RR	$V_{in} = 0.1\text{Vrms}$, $f = 120\text{Hz}$	-	60	-	dB
Slew Rate	SR	$V_o = 2\text{Vp-p}$, $f = 120\text{KHz}$	-	0.8	-	V/us
TRAY DRIVE PART ($V_{CC} = V_{M34} = 8\text{V}$, $R_L = 45\Omega$)						
Input High Level Voltage	V_{ih}		2	-	-	V
Input Low Level Voltage	V_{il}		-	-	0.5	V
Output Voltage1	V_{o1}	$V_{CC} = 8\text{V}$, $V_{ctl} = 4.0\text{V}$	5.2	6	6.8	V
Output Voltage2	V_{o2}	$V_{CC} = 13\text{V}$, $V_{ctl} = 5.7\text{V}$	7.5	8.5	9.5	V
Output Load Regulation	ΔV_{RL}	$V_{CC} = 8\text{V}$, $V_{ctl} = 3.0\text{V}$	-	300	700	mV
Output Offset Voltage1	V_{oo1}	$V_{in} = 5\text{V}$, 5V	-10	-	+10	mV
Output Offset Voltage1	V_{oo2}	$V_{in} = 0\text{V}$, 0V	-10	-	+10	mV
GENERAL OP AMP PART						
Input Offset Voltage	V_{ofop}		-15	-	+15	mV
Input Bias Current	I_{bop}		-	-	300	nA
High Level Output Voltage	V_{ohop}	$V_{CC} = 5\text{V}$, $R_L = 1\text{K}\Omega$	3	4	-	V
Low Level Output Voltage	V_{olop}	$V_{CC} = 5\text{V}$, $R_L = 1\text{K}\Omega$	0.7	1	1.3	V
Output Sink Current	I_{sink}	$V_{CC} = 5\text{V}$, $R_L = 30\Omega$	10	20	-	mA
Output Source Current	I_{source}	$V_{CC} = 5\text{V}$, $R_L = 30\Omega$	10	20	-	mA
Open Loop Voltage Gain	G_{vo}	$V_{in} = -75\text{dB}$, $f = 1\text{KHz}$	-	75	-	dB
Ripple Rejection Ratio	RR_{op}	$V_{in} = -20\text{dB}$, $f = 120\text{Hz}$	-	65	-	dB

Characteristics	Symbol	Conditions	Spec			Unit
			Min	Typ	Max	
Slew Rate	SR _{op}	f = 120KHz, 2V _{p-p}	-	1	-	V/us
Common Mode Rejection Ratio	CMRR	V _{in} = -20dB, f = 1KHz	-	80	-	dB
Common Mode Input Range	V _{icm}	V _{cc} = 8V	-0.3	-	6.8	V

PACKAGE DIMENSIONS

28-SSOPH-375

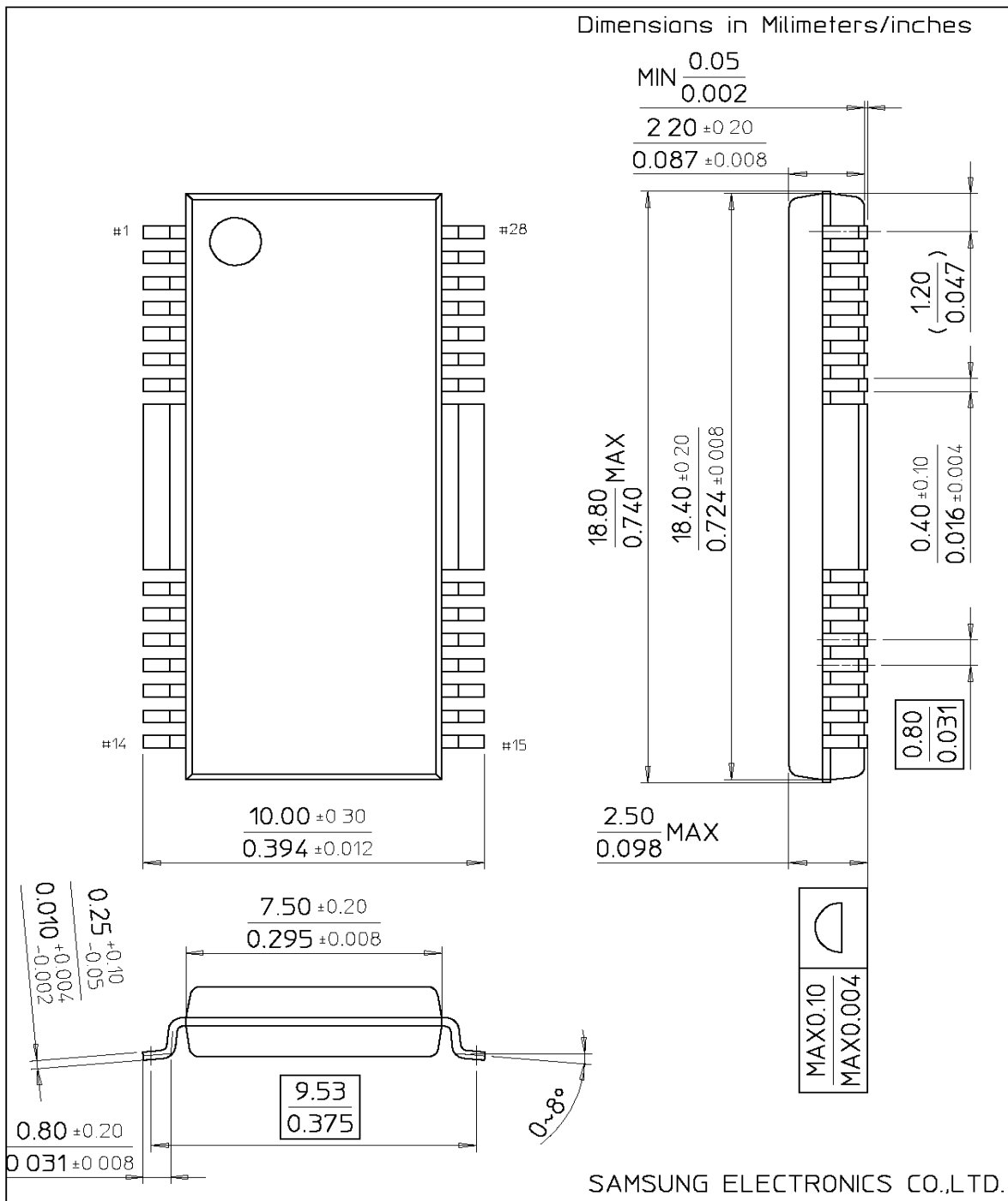

SAMSUNG ELECTRONICS CO.,LTD.

TRADEMARKS

The following are registered and unregistered trademarks Fairchild Semiconductor owns or is authorized to use and is not intended to be an exhaustive list of all such trademarks.

ACEx™	ISOPLANAR™
CoolFET™	MICROWIRE™
CROSSVOLT™	POP™
E ² CMOS™	PowerTrench™
FACT™	QS™
FACT Quiet Series™	Quiet Series™
FAST®	SuperSOT™-3
FASTr™	SuperSOT™-6
GTO™	SuperSOT™-8
HiSeC™	TinyLogic™

DISCLAIMER

FAIRCHILD SEMICONDUCTOR RESERVES THE RIGHT TO MAKE CHANGES WITHOUT FURTHER NOTICE TO ANY PRODUCTS HEREIN TO IMPROVE RELIABILITY, FUNCTION OR DESIGN. FAIRCHILD DOES NOT ASSUME ANY LIABILITY ARISING OUT OF THE APPLICATION OR USE OF ANY PRODUCT OR CIRCUIT DESCRIBED HEREIN; NEITHER DOES IT CONVEY ANY LICENSE UNDER ITS PATENT RIGHTS, NOR THE RIGHTS OF OTHERS.

LIFE SUPPORT POLICY

FAIRCHILD'S PRODUCTS ARE NOT AUTHORIZED FOR USE AS CRITICAL COMPONENTS IN LIFE SUPPORT DEVICES OR SYSTEMS WITHOUT THE EXPRESS WRITTEN APPROVAL OF FAIRCHILD SEMICONDUCTOR CORPORATION. As used herein:

1. Life support devices or systems are devices or systems which, (a) are intended for surgical implant into the body, or (b) support or sustain life, or (c) whose failure to perform when properly used in accordance with instructions for use provided in the labeling, can be reasonably expected to result in significant injury to the user.
2. A critical component is any component of a life support device or system whose failure to perform can be reasonably expected to cause the failure of the life support device or system, or to affect its safety or effectiveness.

PRODUCT STATUS DEFINITIONS

Definition of Terms

Datasheet Identification	Product Status	Definition
Advance Information	Formative or In Design	This datasheet contains the design specifications for product development. Specifications may change in any manner without notice.
Preliminary	First Production	This datasheet contains preliminary data, and supplementary data will be published at a later date. Fairchild Semiconductor reserves the right to make changes at any time without notice in order to improve design.
No Identification Needed	Full Production	This datasheet contains final specifications. Fairchild Semiconductor reserves the right to make changes at any time without notice in order to improve design.
Obsolete	Not In Production	This datasheet contains specifications on a product that has been discontinued by Fairchild semiconductor. The datasheet is printed for reference information only.