

# FAN8026D (KA3026D)

## 4-CH Motor Drive IC

### Features

- 3-Channel BTL driver
- 1-Channel forward-Reverse control DC motor driver
- Built-in thermal shutdown circuit
- Built-in mute circuit
- Operating supply voltage: 4.5~13.2V
- Corresponds to 3.3V or 5V DSP

### Description

The FAN8026D is a monolithic integrated circuit, suitable for a 1-ch (forward.reverse) control DC motor driver and a 3-ch motor driver which drives the focus actuator,tracking actuator, and sled motor of a CD system.

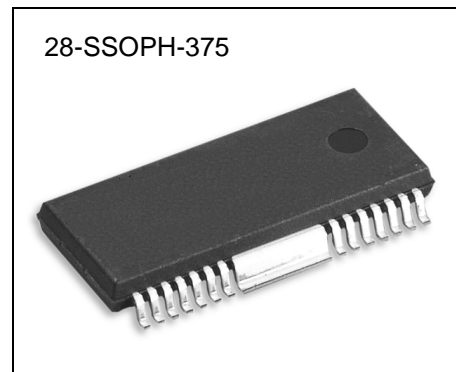

### Typical Applications

- Compact disk player
- Digital video disk player
- Mini disk player

## Pin Assignments

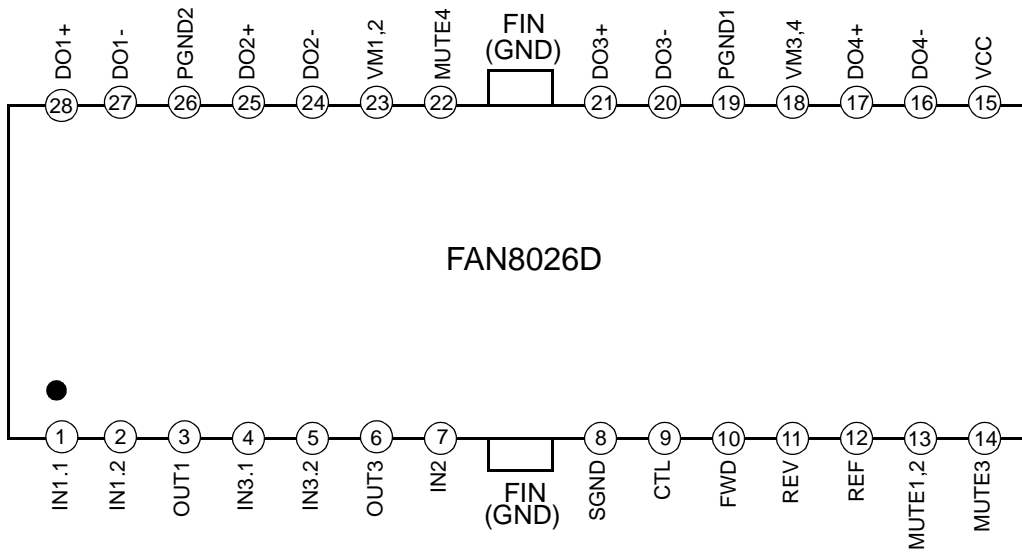

# DC MOTOR DRIVE IC

## Pin Definitions

Pin Number	Pin Name	I/O	Pin Function Description
1	IN1.1	I	OP-AMP CH1 Input (+)
2	IN1.2	I	OP-AMP CH1 Input (-)
3	OUT1	O	OP-AMP CH1 Output
4	IN3.1	I	OP-AMP CH3 Input (+)
5	IN3.2	I	OP-AMP CH3 Input (-)
6	OUT3	O	OP-AMP CH3 Output
7	IN2	I	OP-AMP CH2 Input
8	SGND	-	Signal Ground
9	CTL	I	CH4 Motor Speed Control
10	FWD	I	CH4 Forward
11	REV	I	CH4 Reverse
12	REF	I	Bias Voltage Input
13	MUTE1,2	I	CH1, 2 Mute
14	MUTE3	I	CH3 Mute
15	VCC	-	Signal VCC
16	DO4-	O	Drive4 Output (-)
17	DO4+	O	Drive4 Output (+)
18	VM3, 4	-	BTL CH3, 4 Power VCC
19	PGND1	-	CH3, 4 Power Ground
20	DO3-	O	Drive3 Output (-)
21	DO3+	O	Drive3 Output (+)
22	MUTE4	-	CH4 Mute
23	VM1,2	-	BTL CH1, 2 Power VCC
24	DO2-	O	Drive2 Output (-)
25	DO2+	O	Drive2 Output (+)
26	PGND2	-	CH1,2 Power Ground
27	DO1-	O	Drive1 Output (-)
28	DO1+	O	Drive1 Output (+)

# Internal Block Diagram

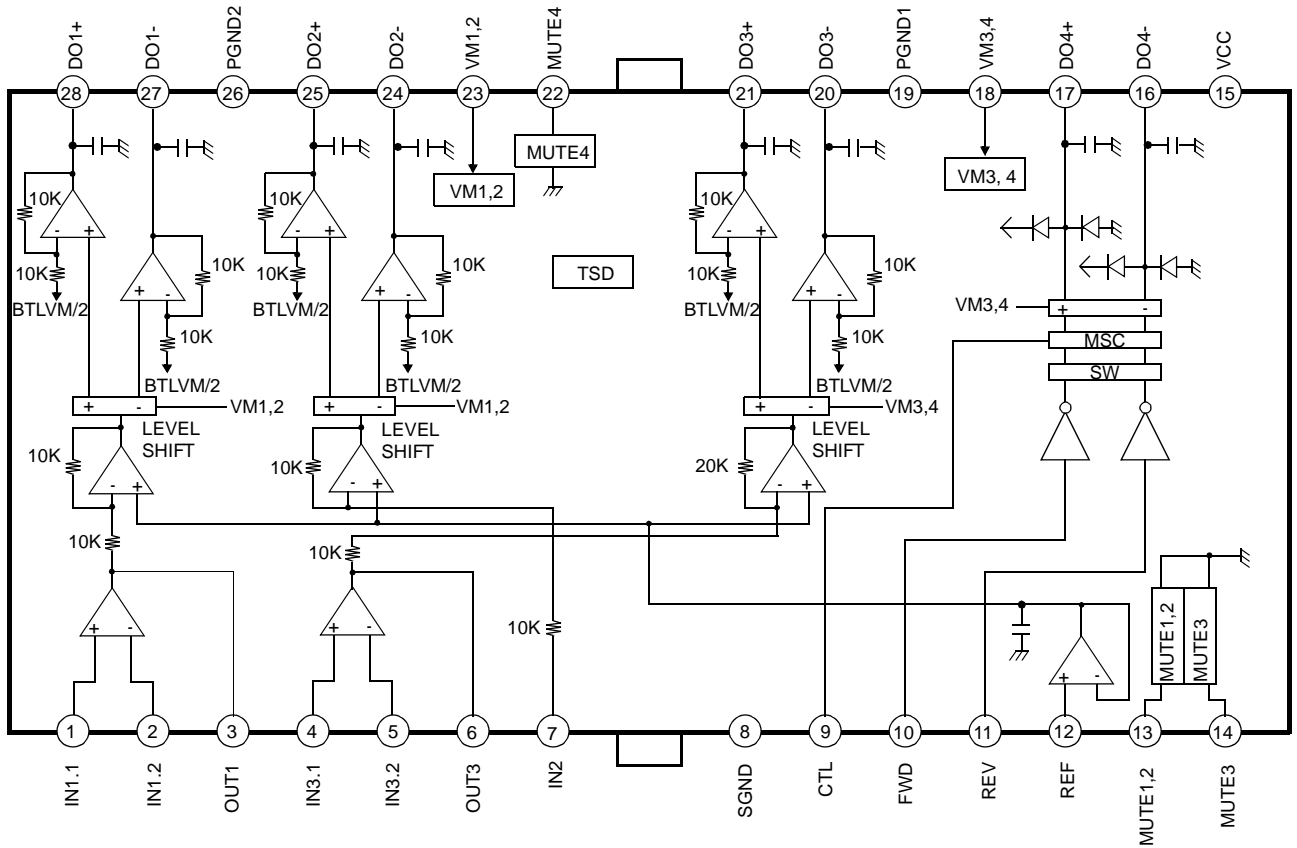

DC MOTOR DRIVE IC

## Equivalent Circuits

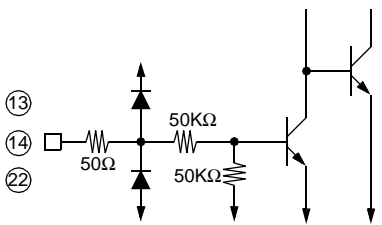
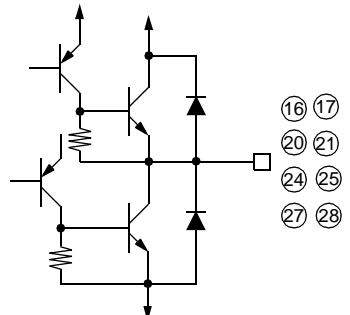
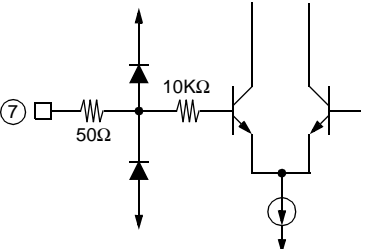
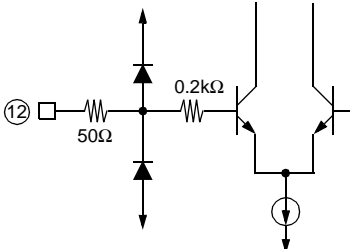
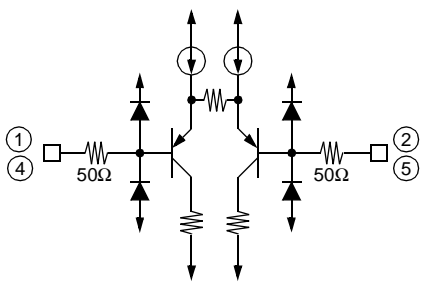
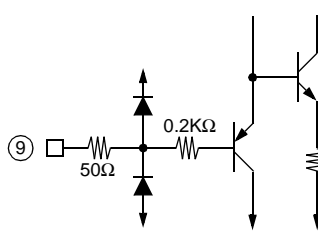
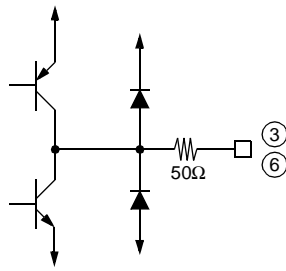
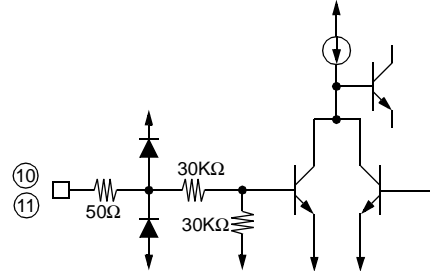
MUTE INPUT	POWER OUTPUT
	
CH2 LEVEL SHIFT INPUT	SIGNAL REFERENCE INPUT
	
ERROR AMP INPUT	LOADING CONTROL INPUT
	
ERROR AMP OUTPUT	LOADING LOGIC INPUT
	

### Absolute Maximum Ratings ( Ta=25°C)

Parameter	Symbol	Value	Unit
Maximum supply voltage	VCCmax	15	V
Power dissipation	Pd	1.7	W
Operating temperature range	Topr	-35 ~ +85	°C
Storage temperature range	Tstg	-55 ~ +150	°C

**Notes:**

1. When mounted on a 50mm × 50mm × 1mm PCB (Phenolic resin material).
2. Power dissipation reduces 13.6mW/°C for using above Ta = 25°C
3. Do not exceed Pd and SOA(Safe operating area).

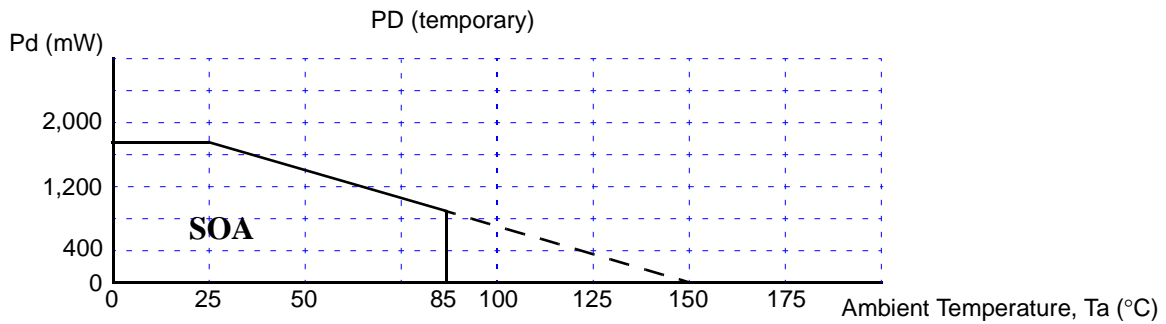

### Recommended Operating Conditions ( Ta=25°C)

Parameter	Symbol	Min.	Typ.	Max.	Unit
Supply Voltage	Vcc	4.5	-	13.2	V

## Electrical Characteristics

(Unless otherwise specified, Ta = 25 °C, VCC = VM1,2 = VM3,4 = 5V)

Parameter	Symbol	Conditions	Min.	Typ.	Max.	Units
Quiescent Current	ICC	Vin = 0V	-	8	12	mA
CH Mute On Current	ImuteCH	Pin 13, Pin14, Pin22 = GND	-	1	3	mA
CH Mute On Voltage	VmonCH	Pin13, Pin14, Pin22 = Variation	-	-	0.5	V
CH Mute Off Voltage	VmoffCH	Pin13, Pin14, Pin22 = Variation	2	-	-	V
<b>DRIVE PART</b>						
Input Offset Voltage	Vio		-20	-	+20	mV
Output Offset Voltage	Voo	Vin = 2.5V	-40	-	+40	mV
Maximum Output Voltage1	Vom1	Vcc=8V, RL = 8Ω (CH1, 2)	4	5.7	-	V
Maximum Output Voltage2	Vom2	Vcc=12V, RL = 24Ω (CH3)	7	9	-	V
Closed Loop Voltage Gain1	Gvc1	f = 1KHz, Vin = 0.1Vrms (CH1, 2)	10.5	12	13.5	dB
Closed Loop Voltage Gain2	Gvc2	f = 1KHz, Vin = 0.1Vrms (CH3)	16	18	20	dB
Ripple Rejection Ratio	RR	Vin = 0.1Vrms, f = 120Hz	-	60	-	dB
Slew Rate	SR	Vo = 2Vp-p, f = 120KHz	-	0.8	-	V/us
<b>ERROR OP AMP PART</b>						
Input Offset Voltage	Vofop		-10	-	+10	mV
Input Bias Current	Ibop		-	-	300	nA
High Level Output Voltage	Vohop	Vcc=8V	7.2	7.6	-	V
Low Level Output Voltage	Volop	Vcc=8V	-	0.2	0.5	V
Output Sink Current	Isink	RL = 1KΩ	2	4	-	mA
Output Source Current	Isource	RL = 1KΩ	2	4	-	mA
Open Loop Voltage Gain	Gvo	Vin = -75dB, f = 1KHz	-	75	-	dB
Ripple Rejection Ratio	RRop	Vin = -20dB, f = 120Hz	-	65	-	dB
Slew Rate	Srop	f = 120KHz, 2Vp-p	-	1	-	V/us
Common Mode Rejection Ratio	CMRR	Vin = -20dB, f = 1KHz	-	80	-	dB
Common Mode Input Range	Vicm		-0.3	-	4.5	V
<b>TRAY DRIVE PART (VCC = VM34 = 8V, RL = 45Ω)</b>						
Input High Level Voltage	Vih		2	-	-	V
Input Low Level Voltage	Vil		-	-	0.5	V
Output Voltage1	Vo1	Vcc=8V, Vctl = 6V	5.2	6.0	6.8	V
Output Voltage2	Vo2	Vcc=13V, Vctl = 8.5V	7.5	8.5	9.5	V
Output Load Regulation	ΔVRL	Vctl = 3.5V	-	300	700	mV
Output Offset Voltage1	Voo1	Vin = 5V, 5V	-10	-	+10	mV
Output Offset Voltage2	Voo2	Vin = 0V, 0V	-10	-	+10	mV

## Application Information

### 1. REFERENCE INPUT

Pin 12 (REF) is a reference Input pin.

1) Reference Input

The applied voltage at the reference input pin must be between 1.5 (V) and 6.5 (V), when  $V_{CC} = 8V$ .

### 2. SEPARATED CHANNEL MUTE FUNCTION

These pins are used for individual channel mute operation.

1) When the mute pins (pin13,14 and 22) are Low level, the mute circuits are enabled and the output circuits are muted.

2) When the voltage of the mute pins (pin13,14 and 22) are High level, the mute circuits are disabled and the output circuits operate normally.

3) If the chip temperature rises above 175 °C, then the thermal shutdown (TSD) circuit is activated and the output circuits are muted.

Mute1, 2 (pin13) - CH1, 2 mute control input pin.

Mute3 (pin14) - CH3 mute control input pin.

Mute4 (pin22) - CH4 mute control input pin.

### 3. PROTECTION FUNCTION

Thermal Shutdown (TSD)

1) If the chip temperature rises above 175 °C the thermal shutdown (TSD) circuit is activated and the output circuit is in the Mute state, that is Off state.

The TSD circuit has a temperature hysteresis of 25 °C.

### 4. FOCUS, TRACKING ACTUATOR, SLED MOTOR DRIVE PART

1) The reference voltage REF is given externally through pin 12.

2) The error amp output signal is amplified by  $R2/R1$  times and then fed to the level shift circuit.

3) The level shift circuit produces the differential output voltages and drives the two output power amplifiers.

Since the differential gain of the output amplifiers is equal to  $2 \times (1 + R4/R3)$ , the output signal of the error amp is amplified by  $(R2/R1) \times 2 \times (1 + R4/R3)$ .

4) If the total gain is insufficient, the input error amp can be used to increase the gain.

5) The bias voltage ( $V_r$ ) is about a half of the supply voltage ( $V_M$ ).

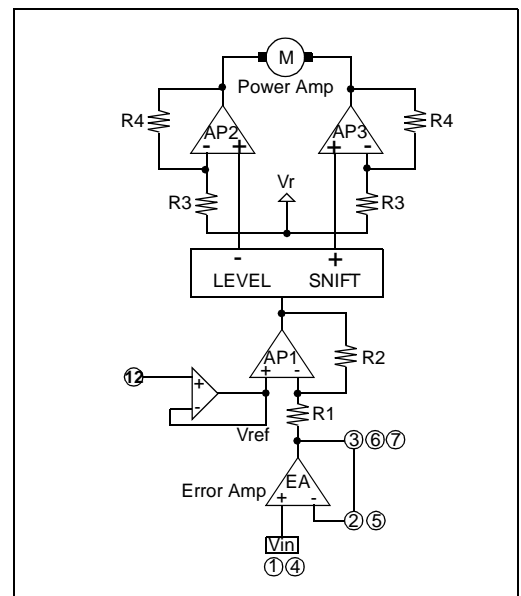

**5. TRAY MOTOR DRIVE PART**

1) Rotational Direction Control

- The forward and reverse rotational direction is controlled by FWD (pin 10) and REV (pin 11) inputs. Conditions are as follows.
- Vr(Power reference voltage) is  $(VM34-VBE) / 2$

Input		Output		
FWD	REV	DO4+	DO4-	State
H	H	Vr	Vr	Brake
H	L	H	L	Forward
L	H	L	H	Reverse
L	L	Vr	Vr	Brake

2) Motor Speed Control

- The motor speed is proportional to the difference voltage between the pin17(DO4+) and the pin16(DO4-).
- By applying the voltage to the pin9 of CTL, the motor speed can be controlled and it is linearly proportional to the applied control voltage.
- When both VM3,4 and Vcc are 8V, and the applied control voltage is higher than 7V, the motor speed is not proportional to the control voltage but the motor speed becomes constant.
- If the pin9 is opened, the motor torque becomes maximum.
- The maximum output swing is 6.0V, when VM3,4 and Vcc are 8V.

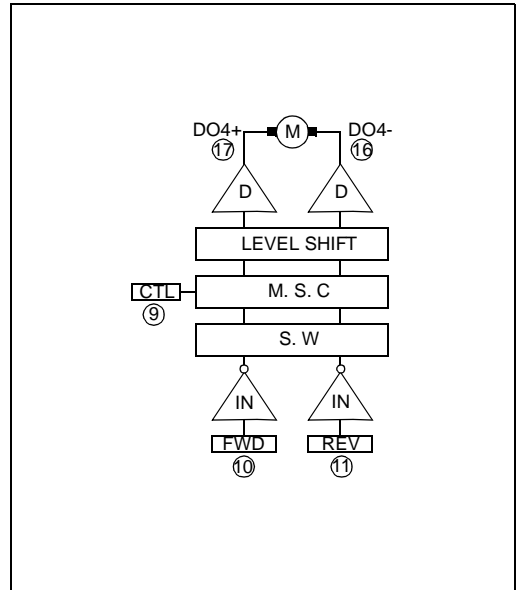

# Typical Performance Characteristics

# DC MOTOR DRIVE IC

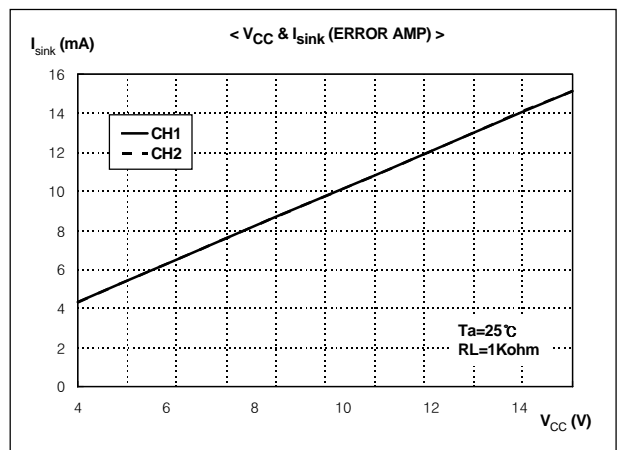
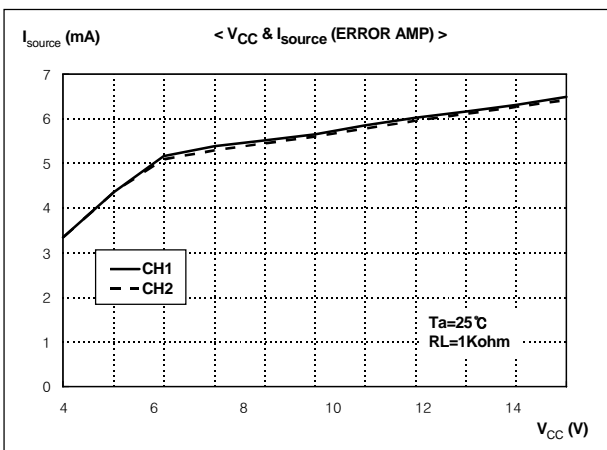
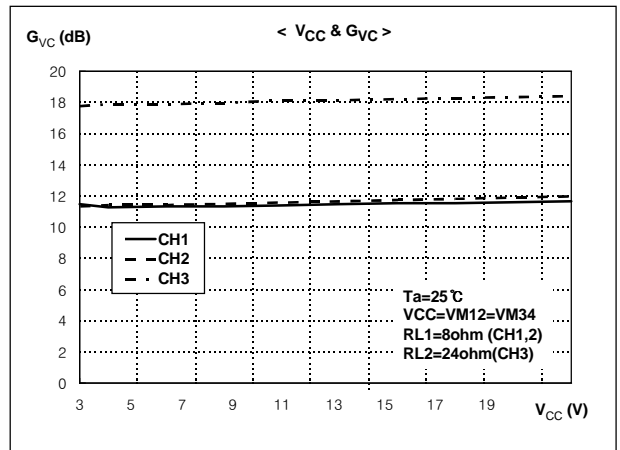
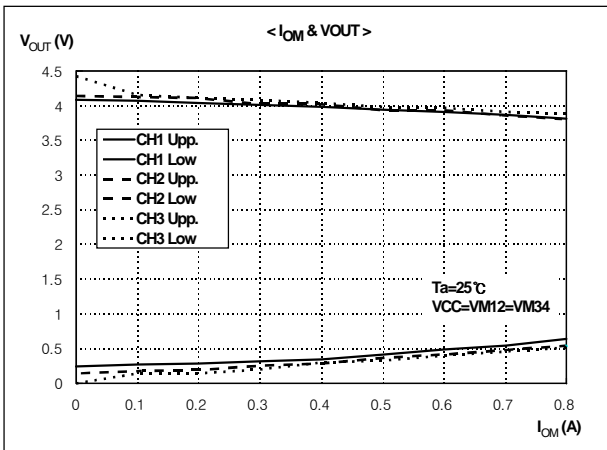
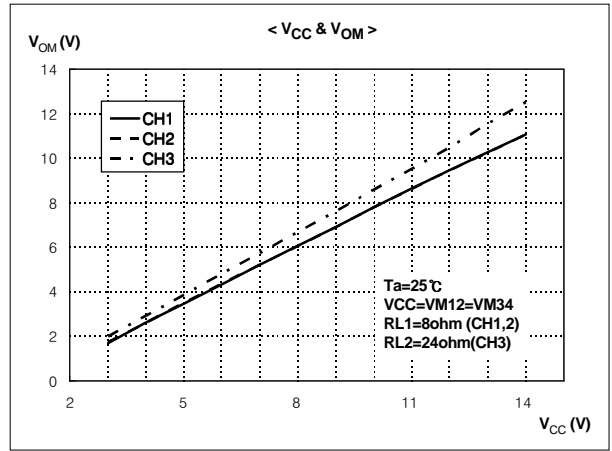
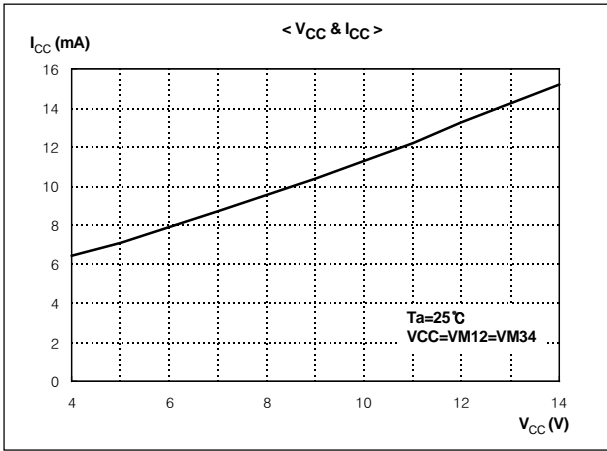

## Typical Performance Characteristics (Continued)

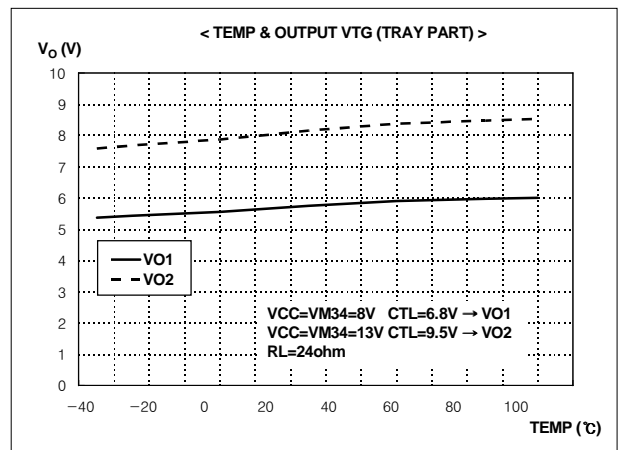
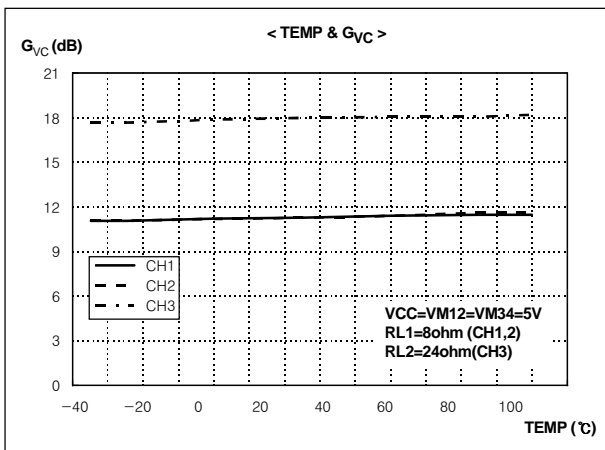
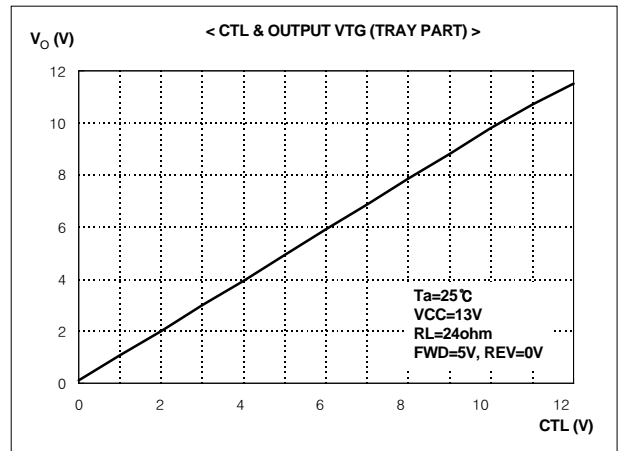
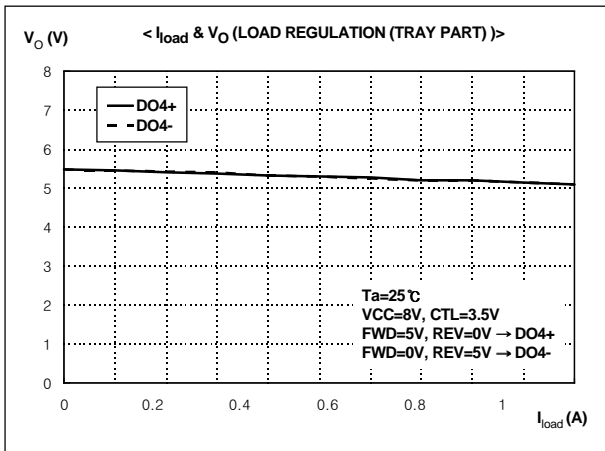

Test Circuits

DC MOTOR DRIVE IC

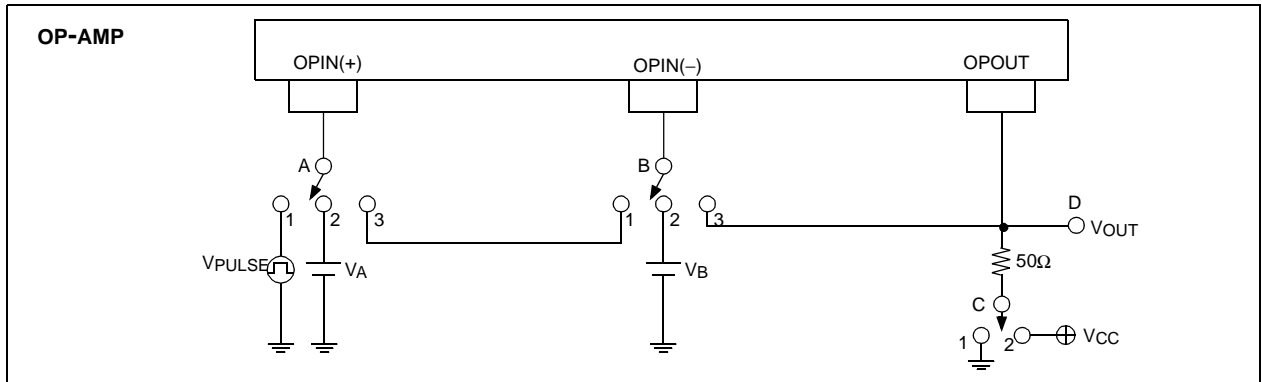
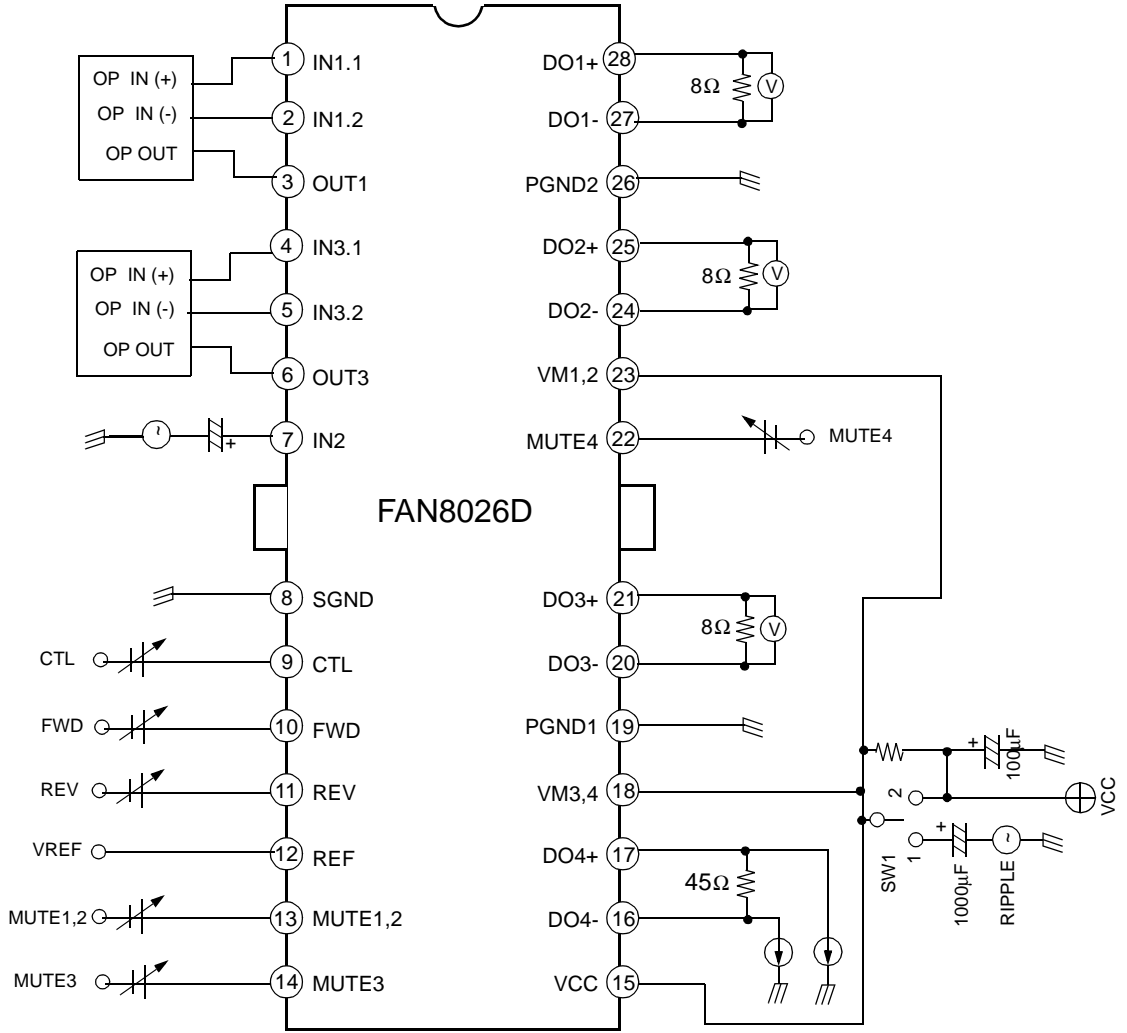

# Typical Application Circuits 1

(Differential PWM Control Mode)

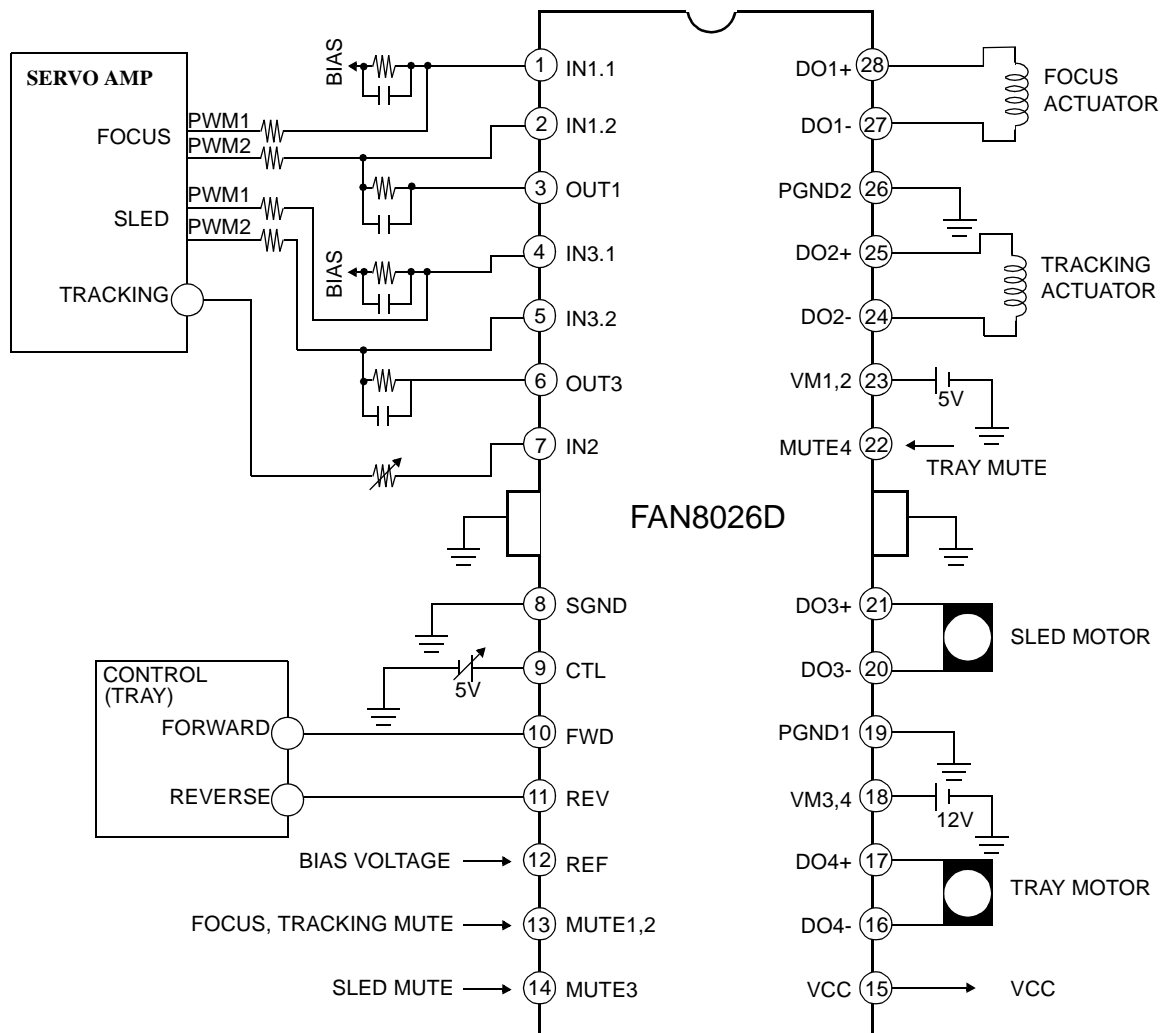

DC MOTOR DRIVE IC

## Typical Application Circuits 2

(Voltage Control Mode)

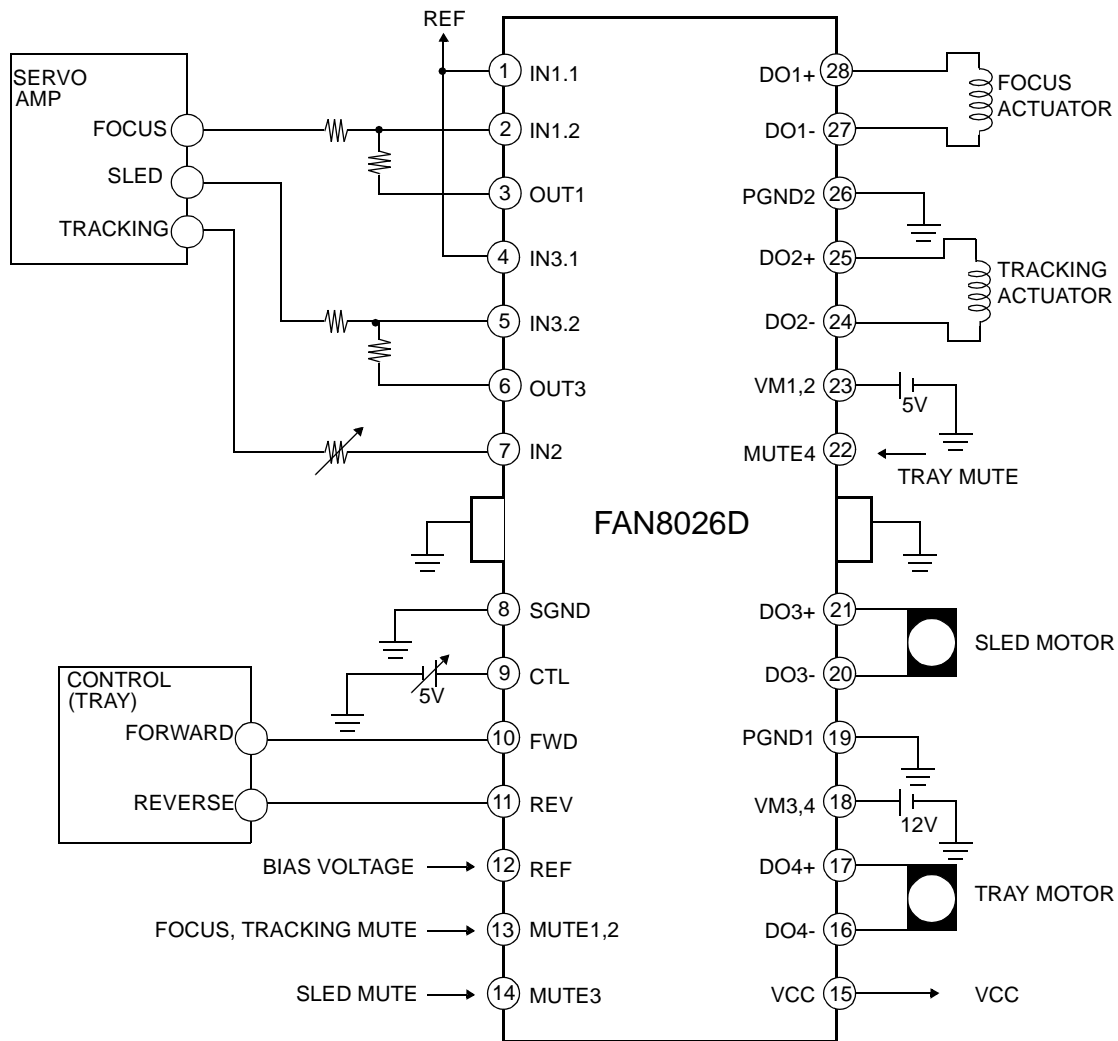

### Ordering Information

Device	Package	Operating Temperature
FAN8026D	28-SSOPH-375	-35 °C ~ 85 °C
FAN8026DTF	28-SSOPH-375	-35 °C ~ 85 °C

# DC MOTOR DRIVE IC

# DC MOTOR DRIVE IC

## LIFE SUPPORT POLICY

FAIRCHILD'S PRODUCTS ARE NOT AUTHORIZED FOR USE AS CRITICAL COMPONENTS IN LIFE SUPPORT DEVICES OR SYSTEMS WITHOUT THE EXPRESS WRITTEN APPROVAL OF THE PRESIDENT OF FAIRCHILD SEMICONDUCTOR CORPORATION. As used herein:

1. Life support devices or systems are devices or systems which, (a) are intended for surgical implant into the body, or (b) support or sustain life, and (c) whose failure to perform when properly used in accordance with instructions for use provided in the labeling, can be reasonably expected to result in a significant injury of the user.
2. A critical component in any component of a life support device or system whose failure to perform can be reasonably expected to cause the failure of the life support device or system, or to affect its safety or effectiveness.