

6-CH MOTOR DRIVER

The KA3030D is a monolithic integrated circuit, suitable for a 6-ch motor drivers which drive focus actuator, tracking actuator, sled motor, spindle motor, loading motor and changer of CD system.

FEATURES

- Wide operating supply voltage range: 4.5V ~ 13.2V
- Built in TSD (Thermal shutdown) circuit
- Built in protection circuit for under or high voltage
- Built in mute circuit
- Built in speed control circuit
- Built in level shift (V-I converter)

TARGET APPLICATION

- CD-PLAYER
- VIDEO-CD
- CAR-CD

28-SSOPH-375

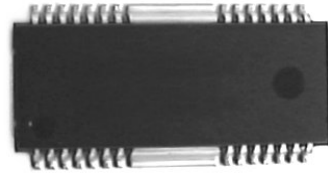

ORDERING INFORMATION

Device	Package	Operating Temperature
KA3030D	28-SSOPH-375	-25°C ~ +75°C

BLOCK DIAGRAM

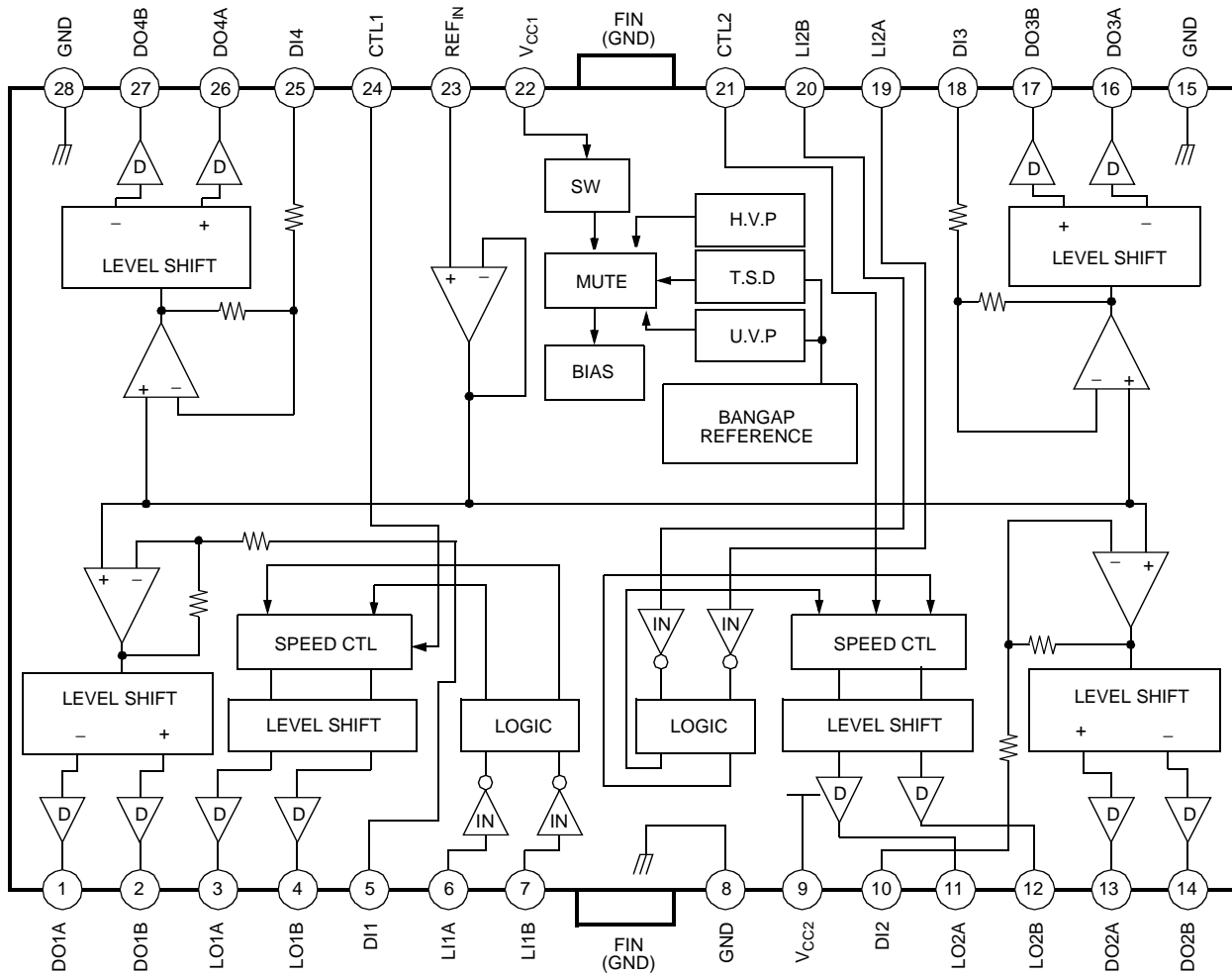

PIN CONFIGURATION

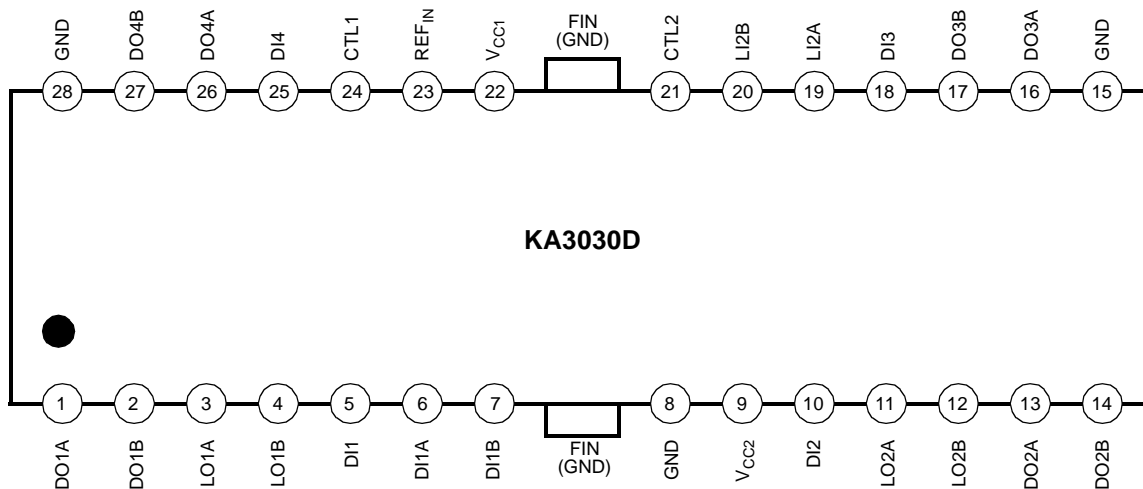

PIN DESCRIPTION

Pin No.	Symbol	I/O	Description	Pin No.	Symbol	I/O	Description
1	DO1A	O	Drive output 1A (-)	15	GND	-	Ground
2	DO1B	O	Drive output 1B (+)	16	DO3A	O	Drive output 3A (-)
3	LO1A	O	Logic output 1A	17	DO3B	O	Drive output 3B (+)
4	LO1B	O	Logic output 1B	18	DI3	I	Drive input 3
5	DI1	I	Drive input 1	19	LI2A	I	Logic input 2A
6	DI1A	I	Logic input 1A	20	LI2B	I	Logic input 2B
7	DI1B	I	Logic input 1B	21	CTL2	I	Speed control 2
8	GND	-	Ground	22	V _{CC1}	-	Power supply 1
9	V _{CC2}	-	Supply voltage 2	23	REF _{IN}	I	Reference & mute input
10	DI2	I	Drive input 2	24	CTL1	I	Speed control 1
11	LO2A	O	Logic output 2A	25	DI4	I	Drive input 4
12	LO2B	O	Logic output 2B	26	DO4A	O	Drive output 4A (+)
13	DO2A	O	Drive output 2A (+)	27	DO4B	O	Drive output 4B (-)
14	DO2B	O	Drive output 2B (-)	28	GND	-	Ground

EQUIVALENT CIRCUIT

Driver input (Except for loading motor driver)	Driver output
Loading motor driver input	Loading motor speed control input
Bias	

ABSOLUTE MAXIMUM RATING (Ta=25°C)

Characteristics	Symbol	Value	Unit
Maximum supply voltage	V_{CCMAX}	18	V
Power dissipation	P_D	@1700	mW
Maximum output current	I_{OMAX}	1	A
Operating temperature	T_{OPR}	-25 ~ 75	°C
Storage temperature	T_{STG}	-55 ~ 150	°C

NOTE:

1. When mounted on 76mm × 114mm × 1.57mm PCB (Phenolic resin material).
2. Power dissipation reduces 13.6mW / °C for using above Ta=25°C
3. Do not exceed Pd and SOA.

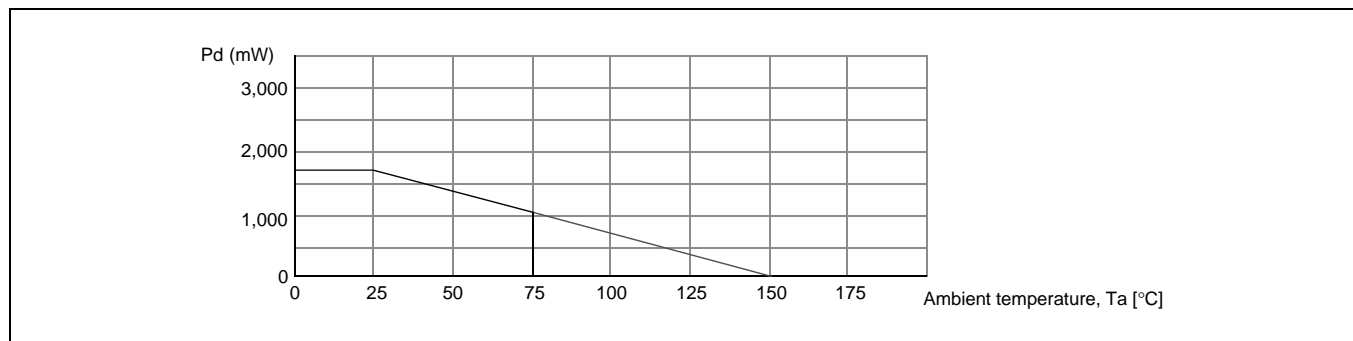
**RECOMMENDED OPERATING CONDITION**

Characteristics	Symbol	Value	Unit
Operating supply voltage ^(note)	V_{CC}	4.5 ~ 13.2	V

NOTE: V_{CC1} (pin 22) \leq V_{CC2} (pin 9)
 V_{CC1} (pin 22) must not exceed V_{CC2} (pin 9)

ELECTRICAL CHARACTERISTICS

(Ta=25°C, V_{CC}=8V, unless otherwise specified)

Characteristics	Symbol	Test conditions	Min.	Typ.	Max.	Unit
Quiescent circuit current	I _{CC}	Under no load	8	11	14	mA
Mute on current	I _{MUTE}	V _{PIN23} =GND	–	3	6	mA
Mute on voltage	V _{MON}	–	–	–	0.5	V
Mute off voltage	V _{MOFF}	–	2	–	–	V
Under voltage protection	V _{UVO}	–	–	–	4	V
High voltage protection	V _{HVP}	–	19	–	–	V
FOCUS, TRACKING, SPINDLE, SLED, DRIVE PART (RL=8Ω)						
Input offset voltage	V _{IO}	–	–20	–	20	mV
Output offset voltage	V _{OO}	V _{IN} =2.5V	–40	–	40	mV
Max. output voltage 1	V _{OM1}	V _{CC} =5V	2.4	3	–	V
Close loop voltage gain 1	A _{VF1}	V _{CC} =5V, V _{IN} =0.1V _{RMS}	7.5	9	10.5	dB
Max. output voltage 2	V _{OM2}	V _{CC} =8V	4.7	5.7	–	V
Close loop voltage gain 2	A _{VF2}	V _{CC} =8V, V _{IN} =0.1V _{RMS}	7.5	9	10.5	dB
Ripple rejection ratio	RR	V _{IN} =0.1V _{RMS} , f=100Hz	40	60	–	dB
Slew rate	SR	Square waveform, V _{out} =3Vp-p, f=100Hz	–	0.8	–	V/μs
LOADING, CHANGER DRIVE PART (RL=45Ω)						
Input high level voltage	V _{IH}	–	2	–	–	V
Input low level voltage	V _{IL}	–	–	–	0.5	V
Output voltage 1	V _{O1}	V _{CC} =5V, V _{CTL} =2.5V	2.6	3.2	3.8	V
Output voltage 2	V _{O2}	V _{CC} =8V, V _{CTL} =3.5V	5.2	6.0	6.8	V
Output load changing 1	ΔV _{RL1}	I _L =100mA→400mA, High terminal	–	100	300	mV
Output load changing 2	ΔV _{RL2}	I _L =100mA→400mA, low terminal	–	100	300	mV
Output offset voltage 1	V _{OO1}	V _{IN} =5V, 5V	–10	–	10	mV
Output offset voltage 2	V _{OO2}	V _{IN} =0V, 0V	–10	–	10	mV

APPLICATION INFORMATION

1. REFERENCE INPUT & MUTE CIRCUITS

Pin 23 can be used as a reference input terminal and a mute terminal.

- Reference input circuit
An external allowable reference voltage to pin 23 is normally 2.5V.
In general conditions pin 23 is used as the reference input terminal and is good to be used between about 2V-6.5V.
- Mute circuit
The following represents the conditions when the external mute is permitted to pin 23.

Mute voltage	Min.	Typ.	Max.	Device condition
Mute on voltage[V]	–	–	0.5	Mute
Mute off voltage[V]	2	–	–	Operate

2. THERMAL SHUT-DOWN CIRCUIT

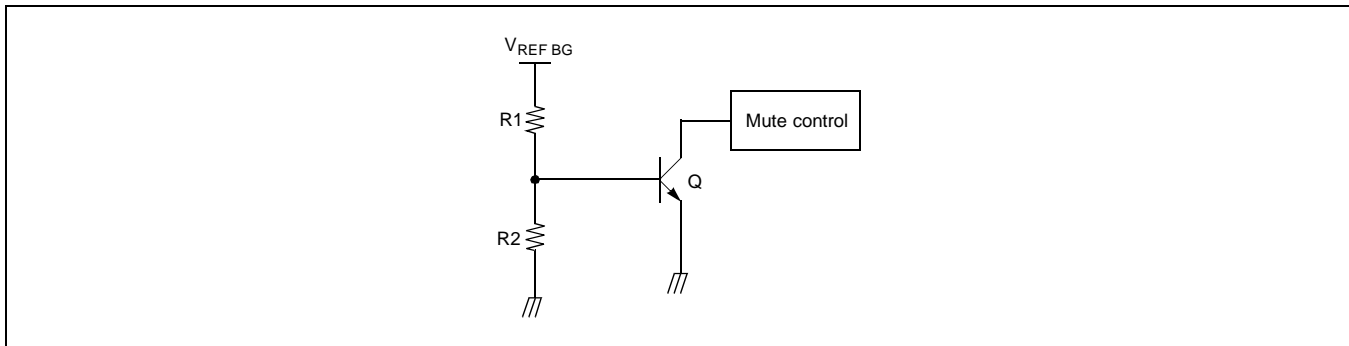

The setting voltage of V_{BE}

$$V_{BE} = V_{REF\ BG} \times R2 / (R1 + R2) = 400mV$$

Because the thermal coefficient of $V_{BE}(Q)$ is $-2mV / 1^{\circ}C$ and if TR Q reaches $175^{\circ}C$ from its normal off state (at $25^{\circ}C$), V_{BE} for turning on Q becomes 400mV, and then Q turns on and the mute control circuit operates.

3. UNDER / HIGH VOLTAGE PROTECTION CIRCUIT

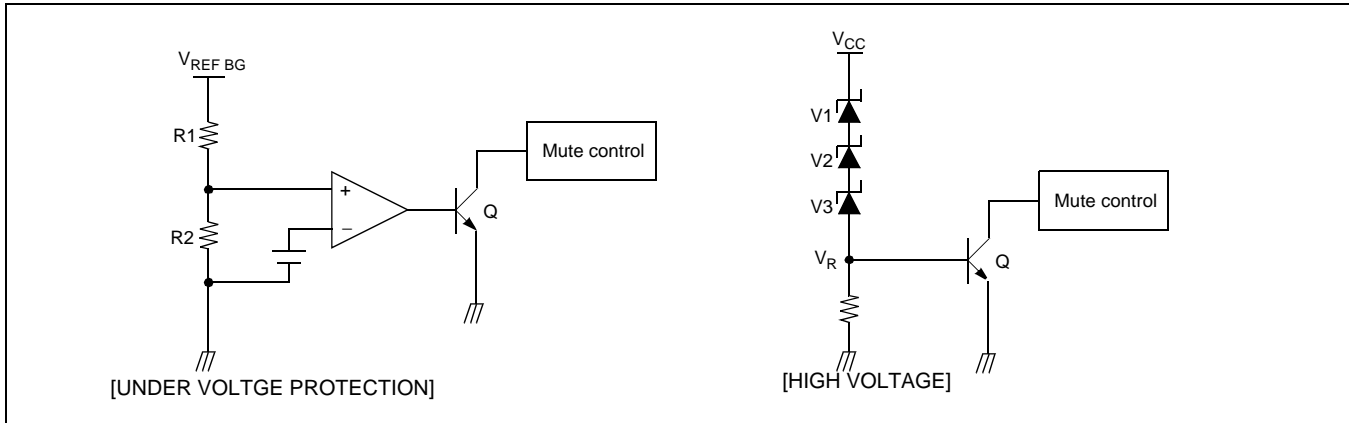

- **[UNDER VOLTGE PROTECTION]**
- Normal state: $V_{BGR} = 2.5V < V1 = V_{CC} \times R2 / (R1 + R2)$
- Normal state: $V_Z = V1 + V2 + V3 + V_R$
- **[HIGH VOLTAGE]**
- Mute state: $V1 < V_{BGR}$ (V_{CC} is below 4V)
- Mute state: $V_{CC} > V_Z$ (V_{CC} is above 20V)

4. FOCUS, TRACKING, SPINDLE, SLED DRIVE CIRCUITS

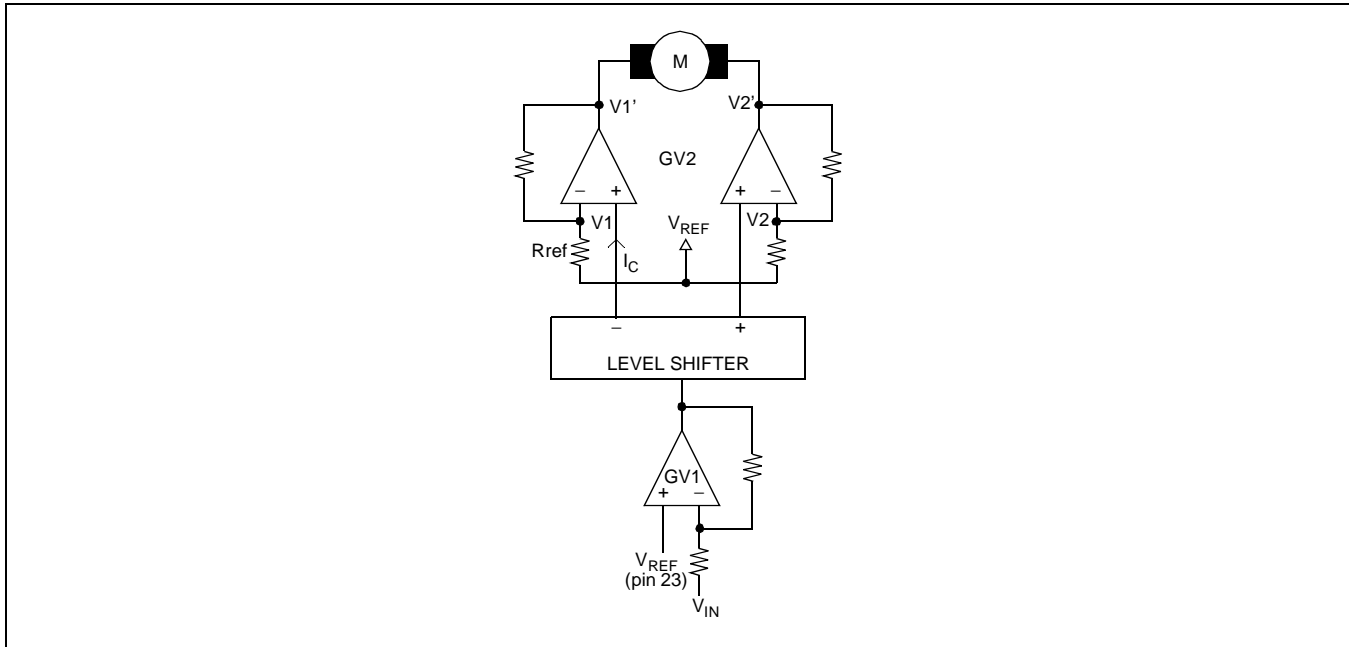

$$GV = 20 \log (V_O/V_{IN}) = GV1 + GV2 = 3.5\text{dB} + 6\text{dB} = 9.5\text{dB}$$

V_{ref} is fixed to 2.5V as the external bias voltage and the input signal through the V_{IN} is amplified to about 9.5dB through two state AMP.

In the level shift circuitry, the input signal is transformed into the current so that the voltage $V1$ and $V2$ are shifted to $V1'$ and $V2'$ respectively.

$$V1' = V1 + (I_C \times V_{REF}) = V1 + \Delta V$$

$$V2' = V2 - (I_C \times V_{REF}) = V2 - \Delta V$$

Because $V1$ and $V2$ voltages, in their initial state, are equal, the voltage, V_M , on the sides of the motor is following $V_M = V1' - V2' = \Delta V - (-\Delta V) = 2\Delta V$

Rotation occurs due to $2\Delta V$ voltage difference at both sides of the motor.

5. LOADING, CHANGER DRIVE CIRCUITS

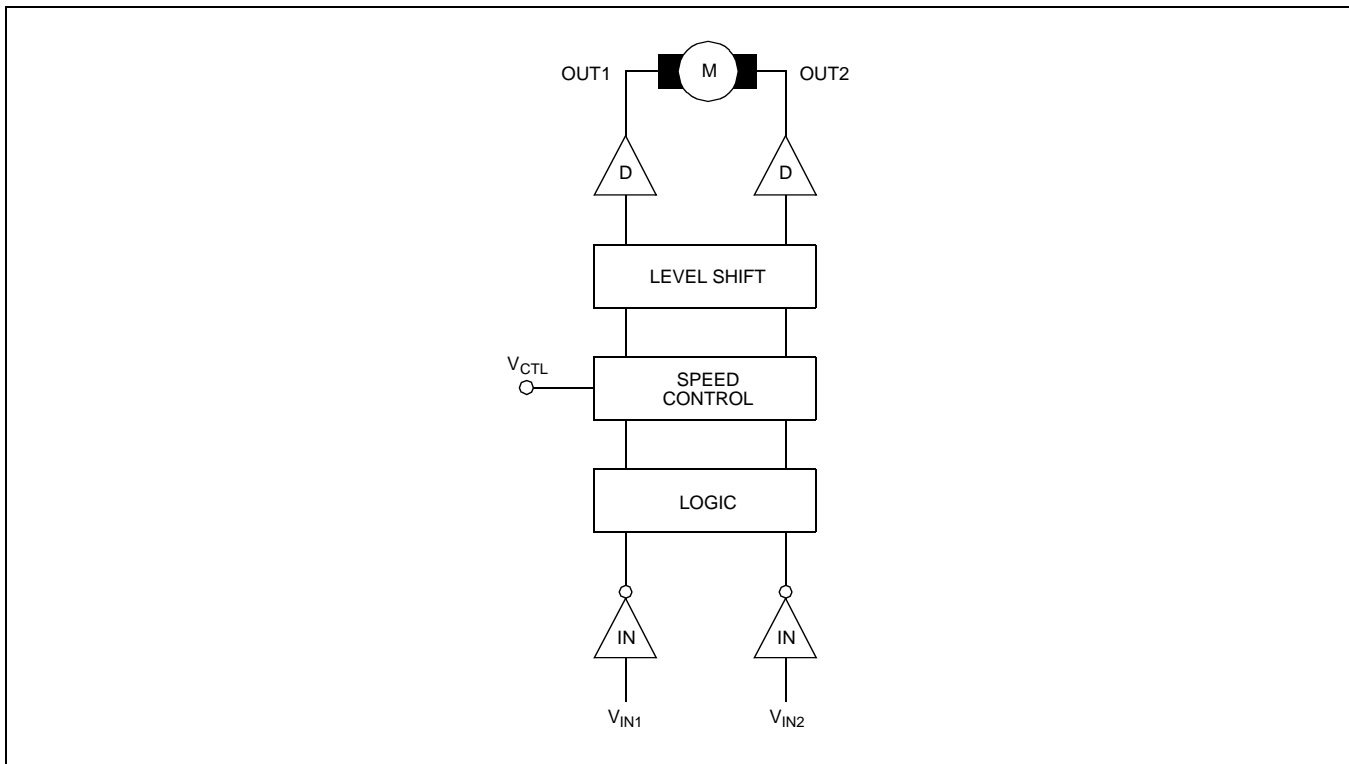

NOTE: V_{CTL} : When the motor speed control voltage is permitted between 0V ~ 4V, the motor varies its speed. Between 4V ~ 5V, the motor can be used at constant speed and over 5.8V, the motor should not be used. Furthermore, when $V_{CC} = 5V$, CTL voltage should not be permitted to exceed 3V

The logic signals, input from the MCU, is inverted in the inverter and can control the changes of the output properties, that depend on the input signal. There properties are shown in the table below.

Logic input A	Pin 6, Pin 19	H	H	L	L
Logic input B	Pin 7, Pin 20	H	L	H	L
Output type		Vr	On	On	Vr
Logic output A	Pin 3, Pin 11		H ^(note)	L	
Logic output B	Pin 4, Pin 12		L	H	

NOTE: The bias voltage Vr is expressed as below;

$$V_r = \frac{V_{CC} - V_{BE}}{2} [V]$$

ELECTRICAL CHARACTERISTICS CURVES

I_{cc}(mA) V_{cc} vs I_{cc}

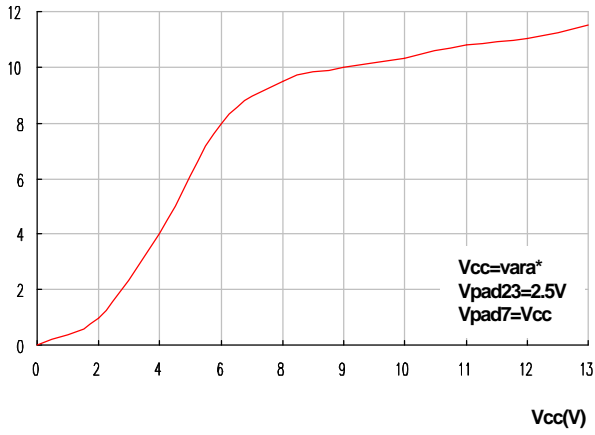

V_{reg}(V) V_{cc} vs V_{reg}

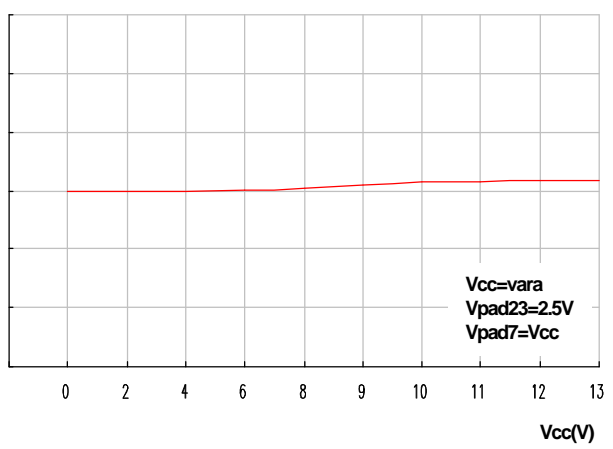

A_v(dB) V_{cc} vs A_v

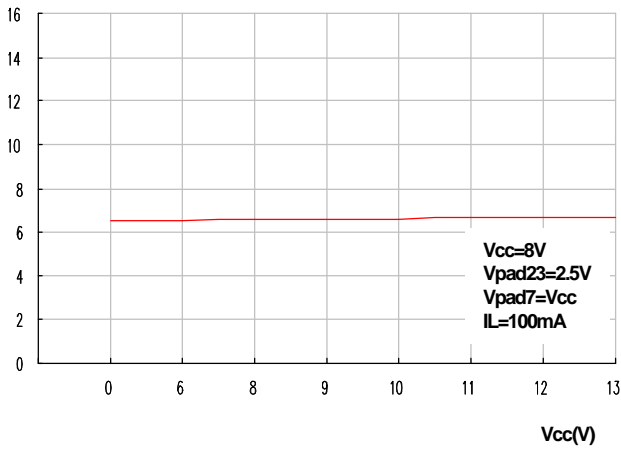

V_{o1}(V) V_{ctl} vs V_{o1}

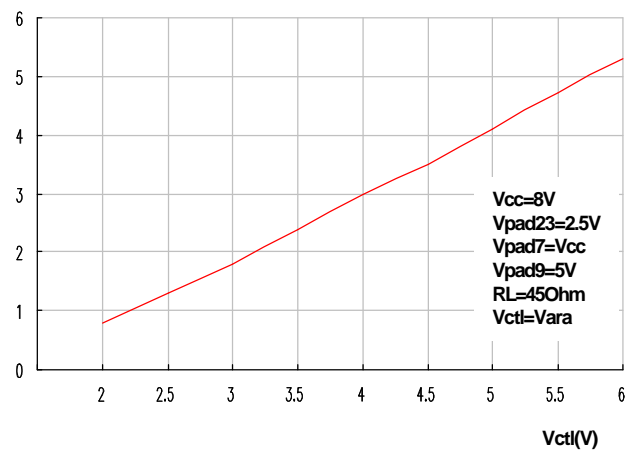

I_{cc}(mA) Temp vs I_{cc}

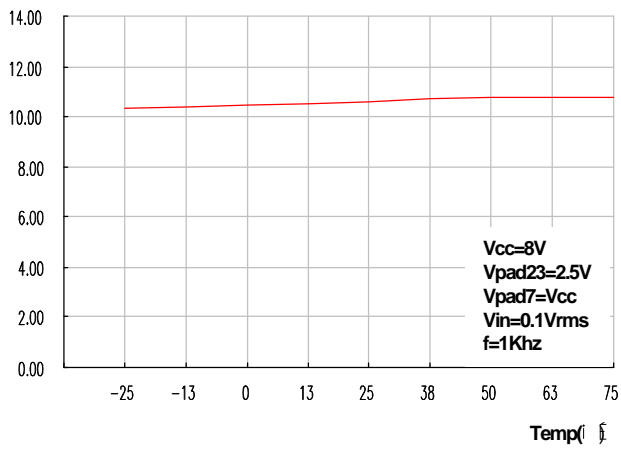

V_{reg}(V) Temp vs V_{reg}

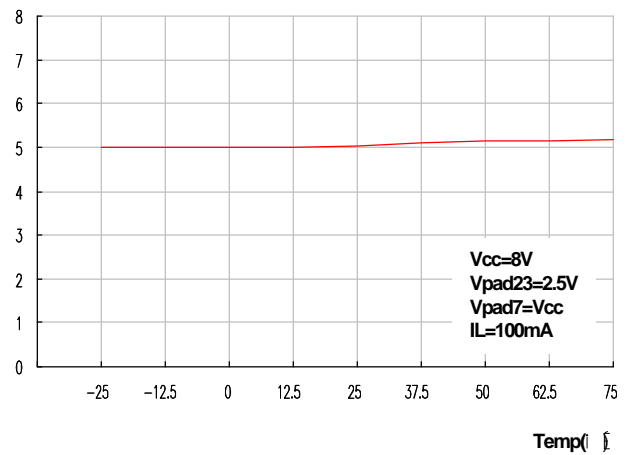

ELECTRICAL CHARACTERISTICS CURVES(CONTINUED)

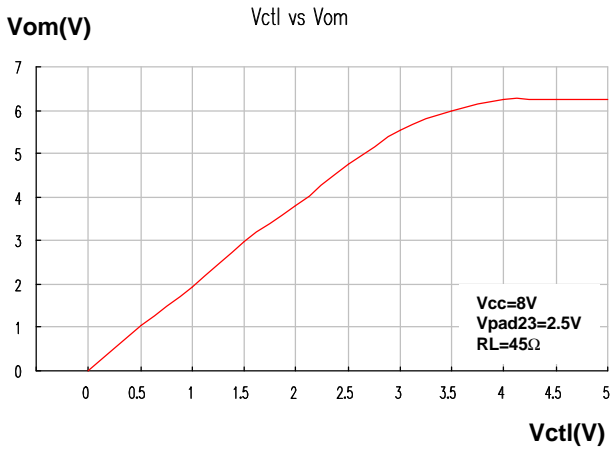
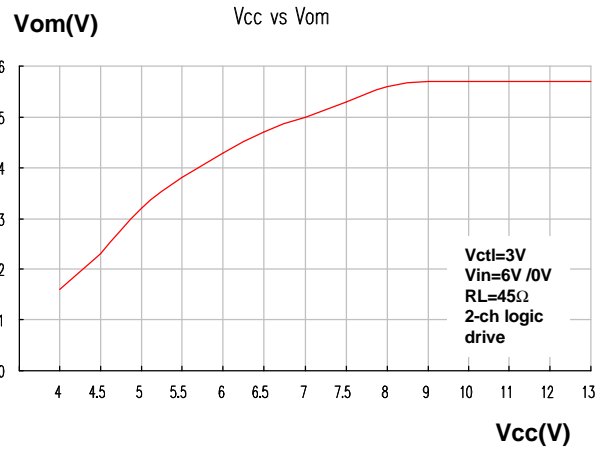
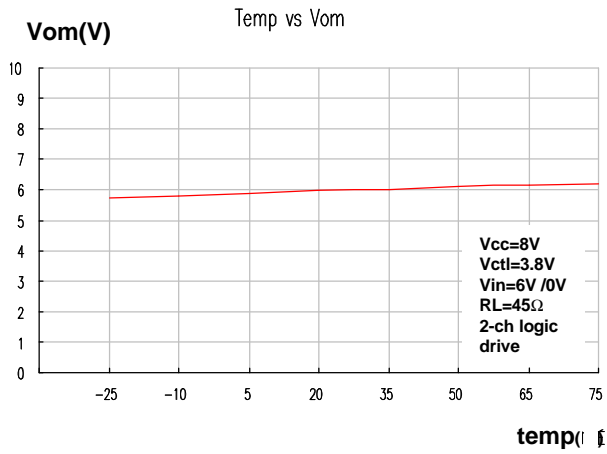

TEST CIRCUIT

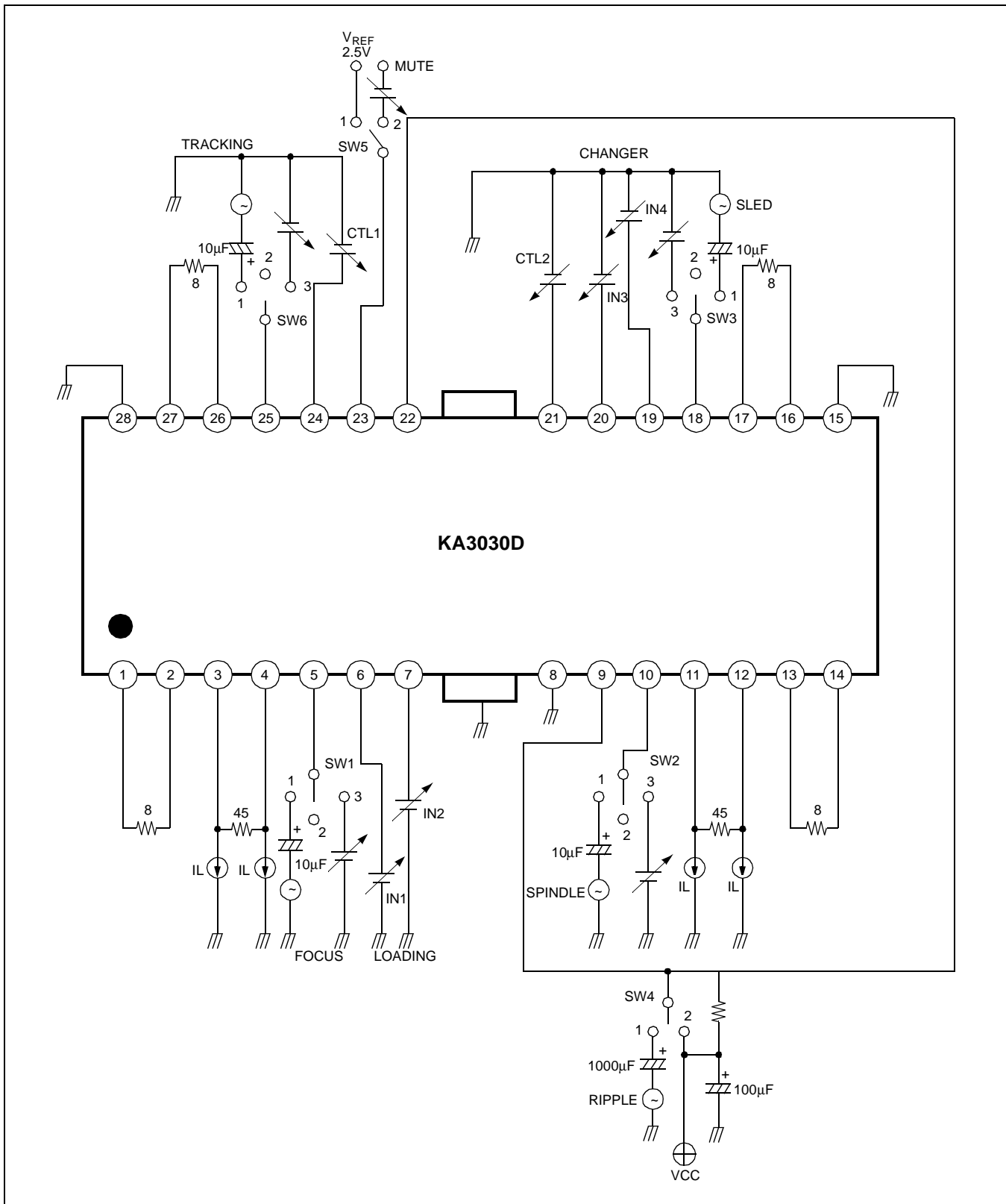

TEST CIRCUIT

(Switch condition)

Characteristics	Symbol	Switch number						Remark
		SW1	SW2	SW3	SW4	SW5	SW6	
Quiescent circuit current	I_{CC}	2	2	2	2	1	2	$R_L = \infty$
Mute on current	I_{MUTE}	2	2	2	2	2	2	
Mute on voltage	V_{MON}	2	2	2	2	2	2	
Mute off voltage	V_{MOFF}	2	2	2	2	2	2	
Under voltage protection	V_{UVP}	2	2	2	2	1	2	
High voltage protection	V_{HVP}	2	2	2	2	1	2	
FOCUS, TRACKING, SPINDLE, DRIVE PRT								
Input offset voltage	V_{IO}	2	2	2	2	1	2	$R_L = 8\Omega$
Output offset voltage	V_{OO}	2	2	2	2	1	2	
Max. output voltage 1	V_{OM1}	3	3	3	2	1	3	
Close loop voltage gain 1	A_{VF1}	1	1	1	2	1	1	
Max. output voltage 2	V_{OM2}	3	3	3	2	1	3	
Close loop voltage gain 2	A_{VF2}	1	1	1	2	1	1	
Ripple rejection ratio	RR	3	3	3	1	1	3	
Slew rate	SR	1	1	1	2	1	1	
LOADING, CHANGER DRIVE PART								
Input high level voltage	V_{IH}	2	2	2	2	1	2	$R_L = 45\Omega$
Input low level voltage	V_{IL}	2	2	2	2	1	2	
Output voltage 1	V_{O1}	2	2	2	2	1	2	
Output voltage 2	V_{O2}	2	2	2	2	1	2	
Output load changing 1	ΔV_{RL1}	2	2	2	2	1	2	
Output load changing 2	ΔV_{RL2}	2	2	2	2	1	2	
Output offset voltage 1	V_{OO1}	2	2	2	2	1	2	
Output offset voltage 2	V_{OO2}	2	2	2	2	-	2	

APPLICATION CIRCUIT

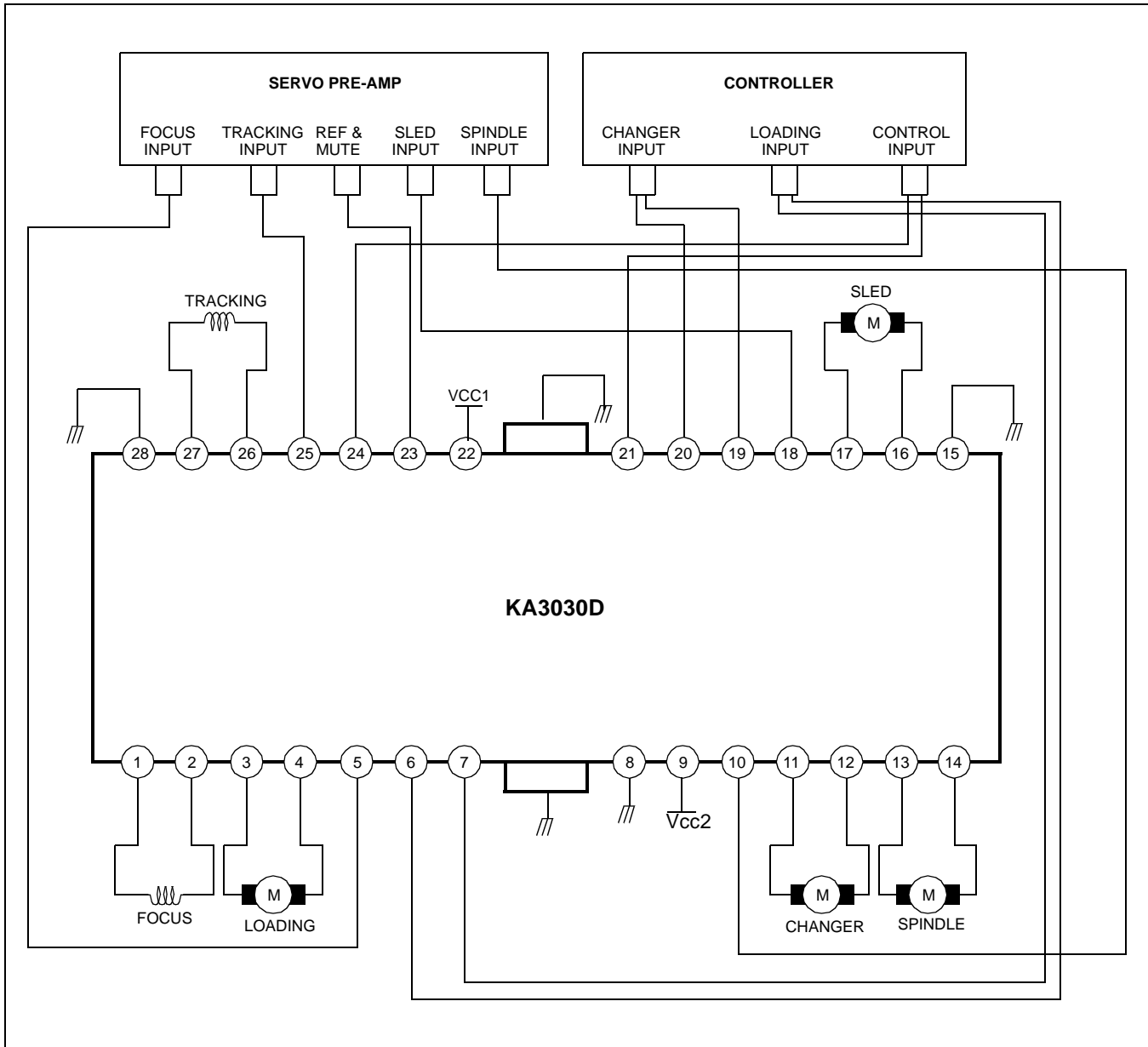

TRADEMARKS

The following are registered and unregistered trademarks Fairchild Semiconductor owns or is authorized to use and is not intended to be an exhaustive list of all such trademarks.

ACEx™	ISOPLANAR™
CoolFET™	MICROWIRE™
CROSSVOLT™	POP™
E ² CMOS™	PowerTrench™
FACT™	QS™
FACT Quiet Series™	Quiet Series™
FAST®	SuperSOT™-3
FASTr™	SuperSOT™-6
GTO™	SuperSOT™-8
HiSeC™	TinyLogic™

DISCLAIMER

FAIRCHILD SEMICONDUCTOR RESERVES THE RIGHT TO MAKE CHANGES WITHOUT FURTHER NOTICE TO ANY PRODUCTS HEREIN TO IMPROVE RELIABILITY, FUNCTION OR DESIGN. FAIRCHILD DOES NOT ASSUME ANY LIABILITY ARISING OUT OF THE APPLICATION OR USE OF ANY PRODUCT OR CIRCUIT DESCRIBED HEREIN; NEITHER DOES IT CONVEY ANY LICENSE UNDER ITS PATENT RIGHTS, NOR THE RIGHTS OF OTHERS.

LIFE SUPPORT POLICY

FAIRCHILD'S PRODUCTS ARE NOT AUTHORIZED FOR USE AS CRITICAL COMPONENTS IN LIFE SUPPORT DEVICES OR SYSTEMS WITHOUT THE EXPRESS WRITTEN APPROVAL OF FAIRCHILD SEMICONDUCTOR CORPORATION. As used herein:

1. Life support devices or systems are devices or systems which, (a) are intended for surgical implant into the body, or (b) support or sustain life, or (c) whose failure to perform when properly used in accordance with instructions for use provided in the labeling, can be reasonably expected to result in significant injury to the user.
2. A critical component is any component of a life support device or system whose failure to perform can be reasonably expected to cause the failure of the life support device or system, or to affect its safety or effectiveness.

PRODUCT STATUS DEFINITIONS

Definition of Terms

Datasheet Identification	Product Status	Definition
Advance Information	Formative or In Design	This datasheet contains the design specifications for product development. Specifications may change in any manner without notice.
Preliminary	First Production	This datasheet contains preliminary data, and supplementary data will be published at a later date. Fairchild Semiconductor reserves the right to make changes at any time without notice in order to improve design.
No Identification Needed	Full Production	This datasheet contains final specifications. Fairchild Semiconductor reserves the right to make changes at any time without notice in order to improve design.
Obsolete	Not In Production	This datasheet contains specifications on a product that has been discontinued by Fairchild semiconductor. The datasheet is printed for reference information only.