

# FAN8037 (KA3037)

## 7-CH Motor Drive IC

### Features

- 4-CH balanced transformerless (BTL) driver
- 3-CH (forward - reverse) control DC motor driver
- Operating supply voltage (4.5 V ~ 13.2 V)
- Built-in thermal shut down circuit (TSD)
- Built-in all channel mute circuit
- Built-in power save mode circuit
- Built-in stand by mode circuit
- Built-in variable regulator

### Description

The FAN8037 is a monolithic integrated circuit suitable for a 7-ch motor driver which drives the tracking actuator, focus actuator, sled motor, tray motor, changer motor, panel motor and, spindle motor of the CDP/CAR-CD systems.

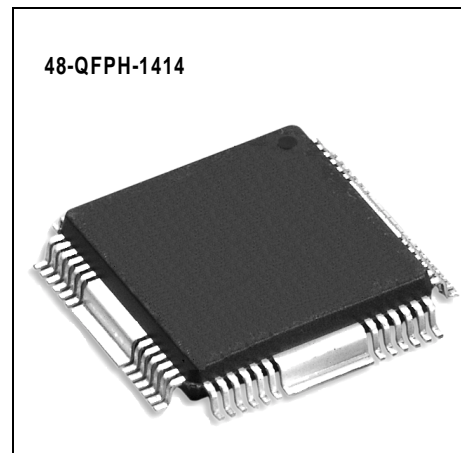

### Typical Application

- Compact disk player (Tray, Changer)
- Video compact disk player (Tray, Changer)
- Car compact disk player (Tray, Changer)
- Mixing with compact disk player and mini disk player (Tray, Changer, Panel)

# Pin Assignments

# DC MOTOR DRIVE IC

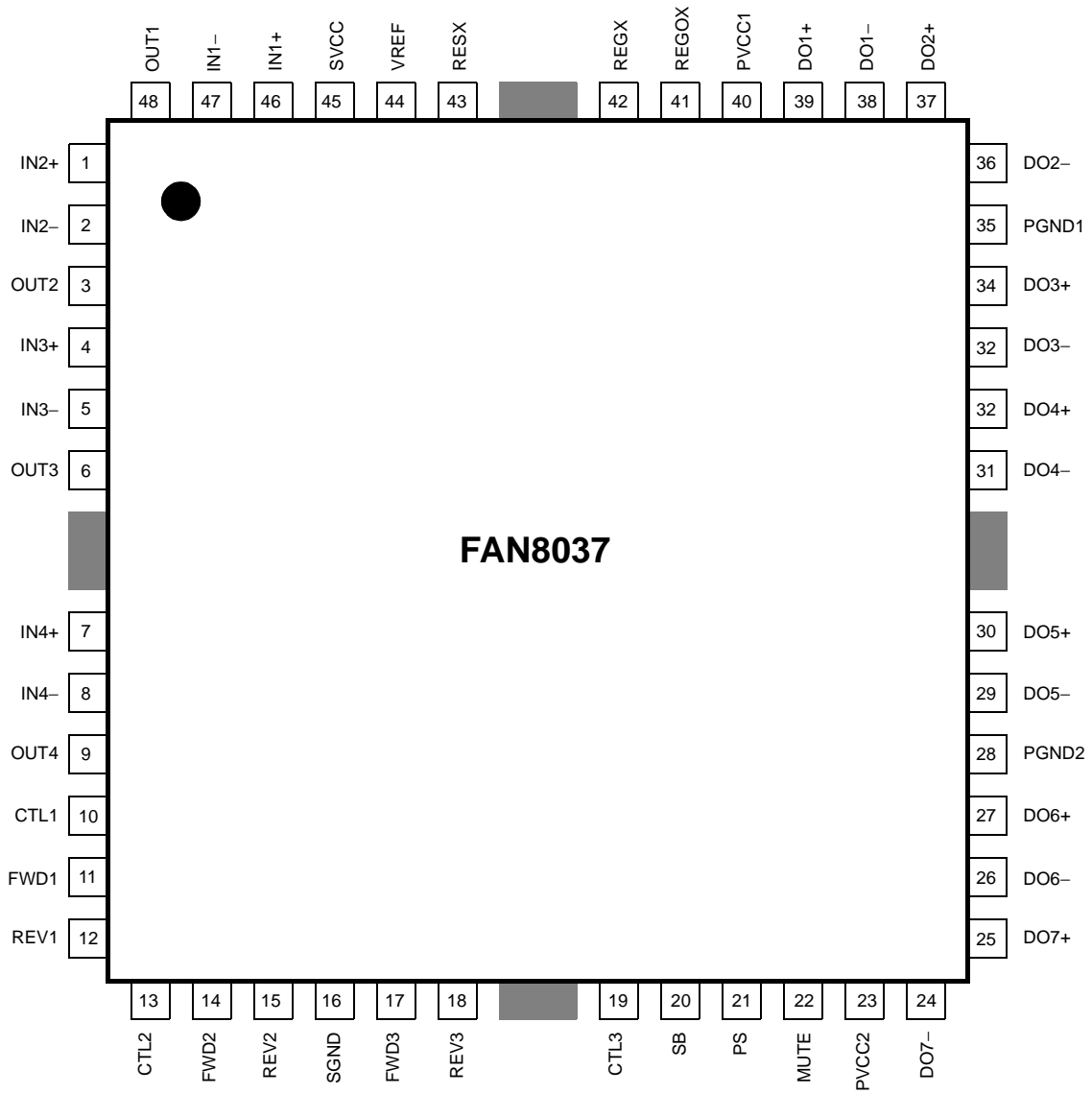

## Pin Definitions

Pin Number	Pin Name	I/O	Pin Function Description
1	IN2+	I	CH2 op-amp input (+)
2	IN2-	I	CH2 op-amp input (-)
3	OUT2	O	CH2 op-amp output
4	IN3+	I	CH3 op-amp input (+)
5	IN3-	I	CH3 op-amp input (-)
6	OUT3	O	CH3 op-amp output
7	IN4+	I	CH4 op-amp input (+)
8	IN4-	I	CH4 op-amp input (-)
9	OUT4	O	CH4 op-amp output
10	CTL1	I	CH5 motor speed control
11	FWD1	I	CH5 forward input
12	REV1	I	CH5 reverse input
13	CTL2	I	CH6 motor speed control
14	FWD2	I	CH6 forward input
15	REV2	I	CH6 reverse input
16	SGND	-	Signal ground
17	FWD3	I	CH7 forward input
18	REV3	I	CH7 reverse input
19	CTL3	I	CH7 motor speed control
20	SB	I	Stand by
21	PS	I	Power save
22	MUTE	I	All mute
23	PVCC2	-	Power supply voltage (For CH5, CH6, CH7)
24	DO7-	O	CH7 drive output (-)
25	DO7+	O	CH7 drive output (+)
26	DO6-	O	CH6 drive output (-)
27	DO6+	O	CH6 drive output (+)
28	PGND2	-	Power ground2 (FOR CH5, CH6, CH7)
29	DO5-	O	CH5 drive output (-)
30	DO5+	O	CH5 drive output (+)
31	DO4-	O	CH4 drive output (-)
32	DO4+	O	CH4 drive output (+)

**Pin Definitions (Continued)**

Pin Number	Pin Name	I/O	Pin Function Description
33	DO3-	O	CH3 drive output (-)
34	DO3+	O	CH3 drive output (+)
35	PGND1	-	Power ground 1 (FOR CH1, CH2, CH3, CH4)
36	DO2-	O	CH2 drive output (-)
37	DO2+	O	CH2 drive output (+)
38	DO1-	O	CH1 drive output (-)
39	DO1+	O	CH1 drive output (+)
40	PVCC1	-	Power supply voltage (FOR CH1, CH2, CH3, CH4)
41	REGOX	I	Regulator feedback input
42	REGX	O	Regulator output
43	RESX	I	Regulator reset input
44	VREF	I	Bias voltage input
45	SVCC	-	Signal supply voltage
46	IN1+	I	CH1 op-amp input (+)
47	IN1-	I	CH1 op-amp input (-)
48	OUT1	O	CH1 op-amp output

# Internal Block Diagram

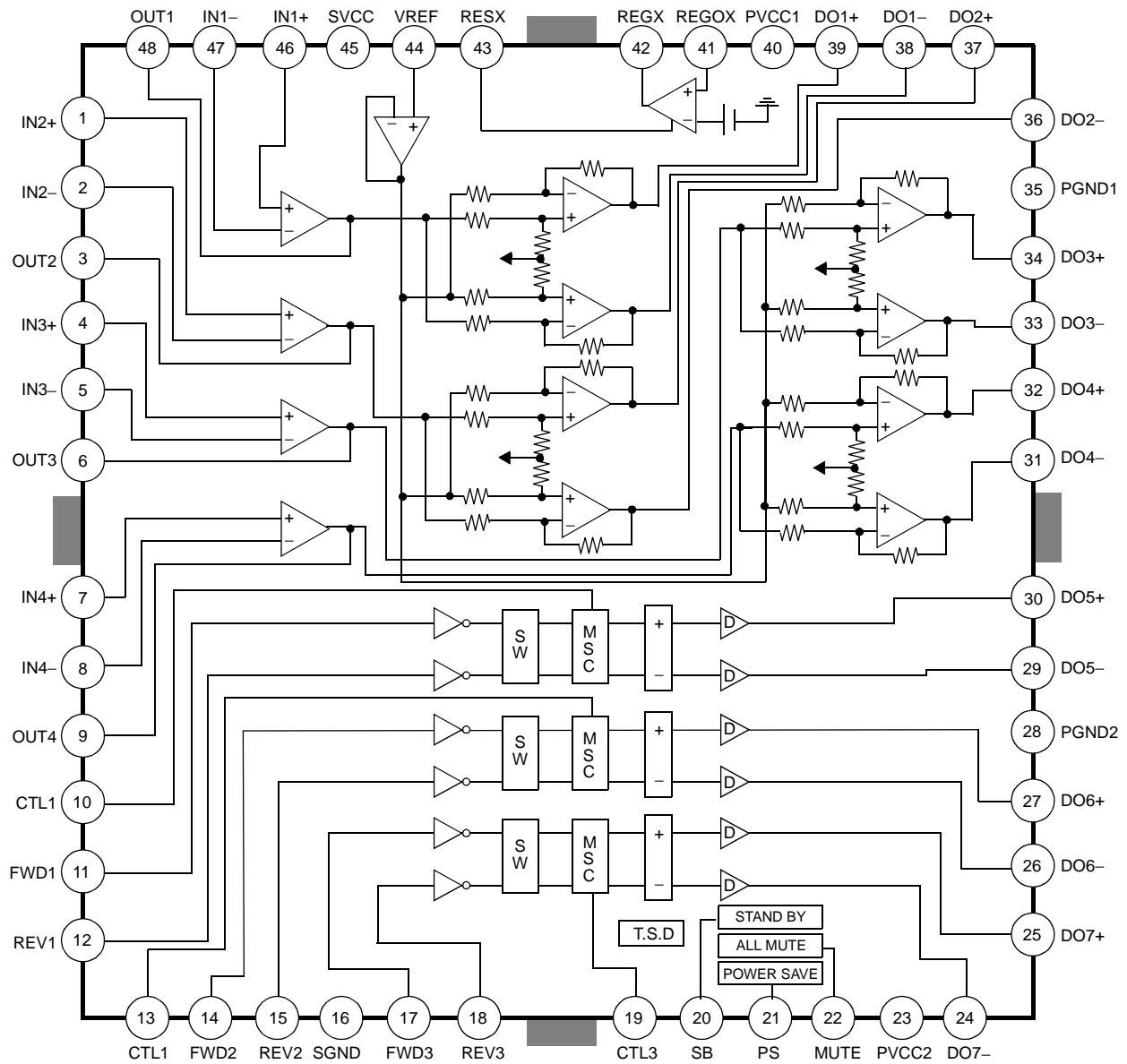

DC MOTOR DRIVE IC

**Notes:**

1. SW = Logic switch
2. MSC = Motor speed control
3. D = Output driver

### Equivalent Circuits

Description	Pin No.	Internal circuit
Input OPIN (+) OPIN (-)	46,47,1,2 4,5,7,8	
Input opout	48,3,6,9	
CTL	10,13,19	
Logic drive FWD input REV input	11,12, 14,15, 17,18	

DC MOTOR DRIVE IC

### Equivalent Circuits (Continued)

Description	Pin No.	Internal circuit
Power save Standby	20,21	
Mute	22	
Logic drive output	24, 25 26, 27 29, 30	
4-CH drive output	31, 32 33, 34 36, 37 38, 39	

### Equivalent Circuits (Continued)

Description	Pin No.	Internal circuit
Ref	44	
RESX	43	
REG0X	41	
REGX	42	

## Absolute Maximum Ratings ( Ta=25°C)

Parameter	Symbol	Value	Unit
Maximum Supply Voltage	SVCCMAX	18	V
	PVCC1	18	V
	PVCC2	18	V
Power Dissipation	P <sub>D</sub>	3 <sup>note</sup>	W
Operating Temperature	T <sub>OPR</sub>	-35 ~ +85	°C
Storage Temperature	T <sub>STG</sub>	-55 ~ +150	°C
Maximum Output Current	I <sub>OMAX</sub>	1	A

### Notes:

1. When mounted on 70mm × 70mm × 1.6mm PCB
2. Power dissipation reduces 24mW/°C for using above T<sub>A</sub> = 25°C
3. Do not exceed P<sub>D</sub> and SOA

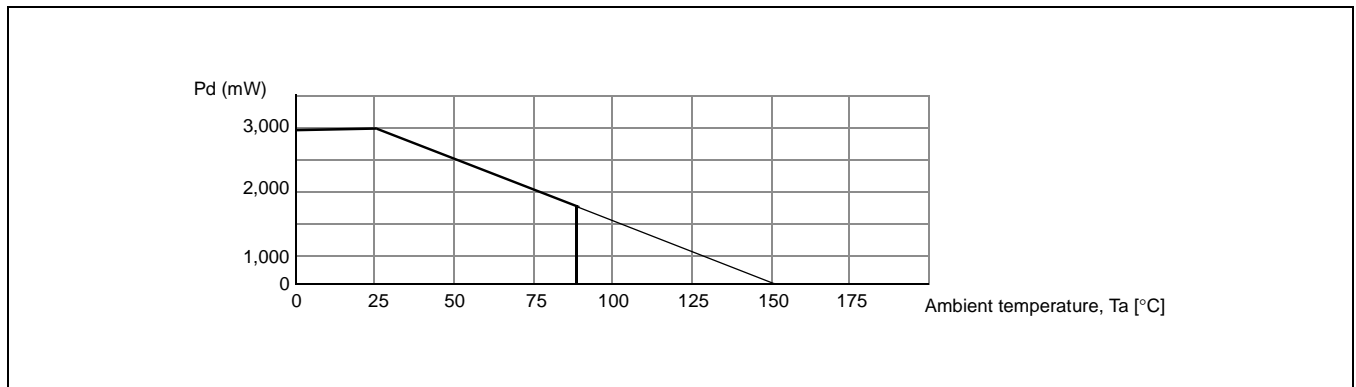

## Recommended Operating Conditions ( Ta=25°C)

Parameter	Symbol	Min.	Typ.	Max.	Unit
Operating Supply Voltage	SVCC	4.5	-	13.2	V
	PVCC1	4.5	-	SVCC	V
	PVCC2	4.5	-	SVCC	V

## Electrical Characteristics

( $S_{VCC} = PV_{CC1} = PV_{CC2} = 8V$ ,  $T_A = 25^\circ C$ , unless otherwise specified)

Parameter	Symbol	Conditions	Min.	Typ.	Max.	Units
Quiescent circuit current	ICC	Under no-load	15	25	35	mA
Power save on current	IPS	Pin21=GND	-	1	2	mA
Stand by on voltage	VSBON	Pin20=Variation	-	-	0.5	V
Stand by off voltage	VSBOFF	Pin20=Variation	2	-	-	V
Power save on voltage	VPSON	Pin21=Variation	-	-	0.5	V
Power save off voltage	VPSONOFF	Pin21=Variation	2	-	-	V
All mute on voltage	VMON	Pin22=Variation	-	-	0.5	V
All mute off voltage	VMOFF	Pin22=Variation	2	-	-	V
<b>DRIVER PART (RL=8Ω)</b>						
Output offset voltage	VOO	VIN=2.5V	-80	-	+80	mV
Maximum output voltage 1	VOM1	VCC=PVCC1=PVCC2=8V, RL=8Ω	5.5	6.5	-	V
Maximum output voltage 2	VOM2	VCC=PVCC1=PVCC2=13V, RL=24Ω	10.5	11.5	-	V
Closed-loop voltage gain	AVF	VIN=0.1Vrms	10.5	12	13.5	dB
Slew rate	SR	Square, Vout=4Vp-p, f=120kHz	-	2	-	V/μs
<b>INPUT OPAMP PART</b>						
Input offset voltage	VOF	-	-30	-	+30	mV
Input bias current	IB	-	-	-	300	nA
High level output voltage	VOH	RL=Open	7.2	7.7	-	V
Low level output voltage	VOL	RL=Open	-	0.2	0.5	V
Output sink current	ISINK	RL=50Ω	2	4	-	mA
Output source current	ISOURCE	RL=50Ω	2	4	-	mA
Open loop voltage gain	GVO	VIN=-75dB	-	70	-	dB
Slew rate	SR	Square, Vout=2Vp-p, f=120kHz	-	2.5	-	V/μs

## Electrical Characteristics (Continued)

( $S_{VCC} = P_{VCC1} = P_{VCC2} = 8V$ ,  $T_A = 25^\circ C$ , unless otherwise specified)

Parameter	Symbol	Conditions	Min.	Typ.	Max.	Units
<b>TRAY, CHANGER, PANEL DRIVE PART (<math>R_L=45\Omega</math>)</b>						
Input high level voltage	$V_{IH}$	-	2	-	-	V
Input low level voltage	$V_{IL}$	-	-	-	0.5	V
Output voltage 1	$V_{O1}$	$V_{CC}=8V$ , $V_{CTL}=3V$ , $R_L=8\Omega$	-	5	-	V
Output voltage 2	$V_{O2}$	$V_{CC}=8V$ , $V_{CTL}=3V$ , $R_L=45\Omega$	-	6	-	V
Output voltage 3	$V_{O3}$	$V_{CC}=13V$ , $V_{CTL}=4.5V$ , $R_L=45\Omega$	-	9	-	V
Output load regulation	$\Delta V_{RL}$	$V_{CTL}=3V$ , $I_L=100mA \rightarrow 400mA$	-	300	700	mV
Output offset voltage 1	$V_{OO1}$	$V_{IN}=5V$ , $5V$	-40	-	+40	mV
Output offset voltage 2	$V_{OO2}$	$V_{IN}=0V$ , $0V$	-40	-	+40	mV
<b>VARIABLE REGULATOR PART</b>						
Load regulation	$\Delta V_{RL}$	$I_L=0 \rightarrow 200mA$	-40	0	+10	V
Line regulation	$\Delta V_{CC}$	$I_L=200mA$ , $V_{CC}=6V \rightarrow 9V$	-20	0	+30	mV
Regulator output voltage 1	$V_{REG1}$	$I_L=100mA$	4.75	5.0	5.25	V
Regulator output voltage 2	$V_{REG2}$	$I_L=100mA$	3.135	3.3	3.465	V
Regulator reset on voltage	Reson	Pin43=Varivation	-	-	0.5	V
Regulator reset off voltage	Resoff	Pin43=Varivation	2	-	-	V

## Application Information

### 1. THERMAL SHUTDOWN

- When the chip temperature reaches to 175°C, then the TSD circuit is activated.
- This shut down the bias current of the output drivers, and all the output drivers are in cut-off state. Thus the chip temperature begin to decrease.
- when the chip temperature falls to 150°C, the TSD circuit is deactivated and the output drivers are normally operated.
- The TSD circuit has the hysteresis temperature of 25°C.

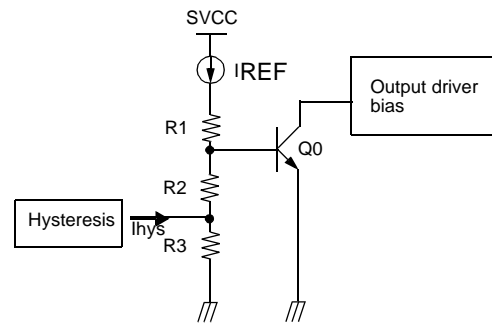

### 2. ALL MUTE FUNCTION

- When the pin22 is high, the TR Q1 is turned on and Q2 is off, so the bias circuit is enabled. On the other hand, when the pin22 is Low (GND), the TR Q1 is turned off and Q2 is on, so the bias circuit is disabled.
- That is, this function will cause all the output drivers to be in mute state.
- Truth table is as follows;

Pin#22	FAN8037
HIGH	MUTE-OFF
LOW	MUTE-ON

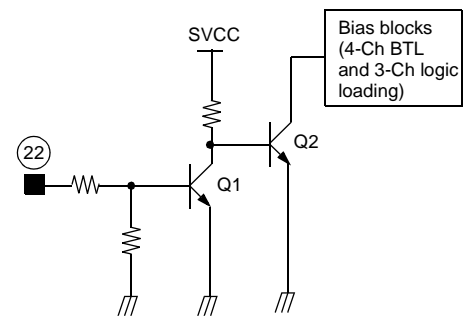

### 3. POWER SAVE FUNCTION

- When the pin21 is high, the TR Q3 is turned on and Q4 is off, so the bias circuit is enabled. On the other hand, when the pin21 is Low (GND), the TR Q3 is turned off and Q4 is on, so the bias circuit is disabled.
- That is, this function will cause all the circuit blocks of the chip except for the variable regulator to be in the off state. thus the low power quiescent state is established
- Truth table is as follows;

Pin#21	FAN8037
HIGH	POWER SAVE OFF
LOW	POWER SAVE ON

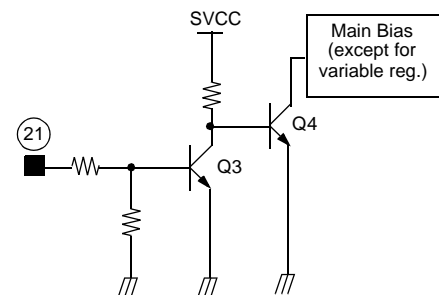

#### 4. STANDBY FUNCTION

- When the pin20 is high, the TR Q5 is turned on and Q6 is off, so the bias circuit is enabled. On the other hand, when the pin20 is Low (GND), the TR Q5 is turned off and Q6 is on, so the bias circuit is disabled.
- That is, this function will cause the output drivers of the 4-CH BTL part(Focus, Tracking, Spindle, Sled) to be in off state.
- Truth table is as follows

Pin#20	KA3037
HIGH	STANDBY OFF
LOW	STANDBY ON

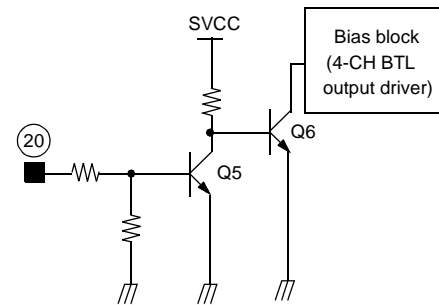

#### 5. REGULATOR & RESET FUNCTION

The regulator and reset circuits are illustrated in the figure 1.

- The external circuit is composed of the PNP transistor(KSB772), capacitor(about 33μF) and 2 feedback resistors.
- The capacitor is used as a ripple eliminator and should have good temperature characteristics.
- The regulator output voltage is decided as follows.  

$$V_{REG} = (1 + R1/R2) \times 2.5$$
- When the voltage of the pin 43 (Vreset) is high, the regulator circuit operates normally. If the voltage of pin 43 is low, the regulator circuit is disabled.

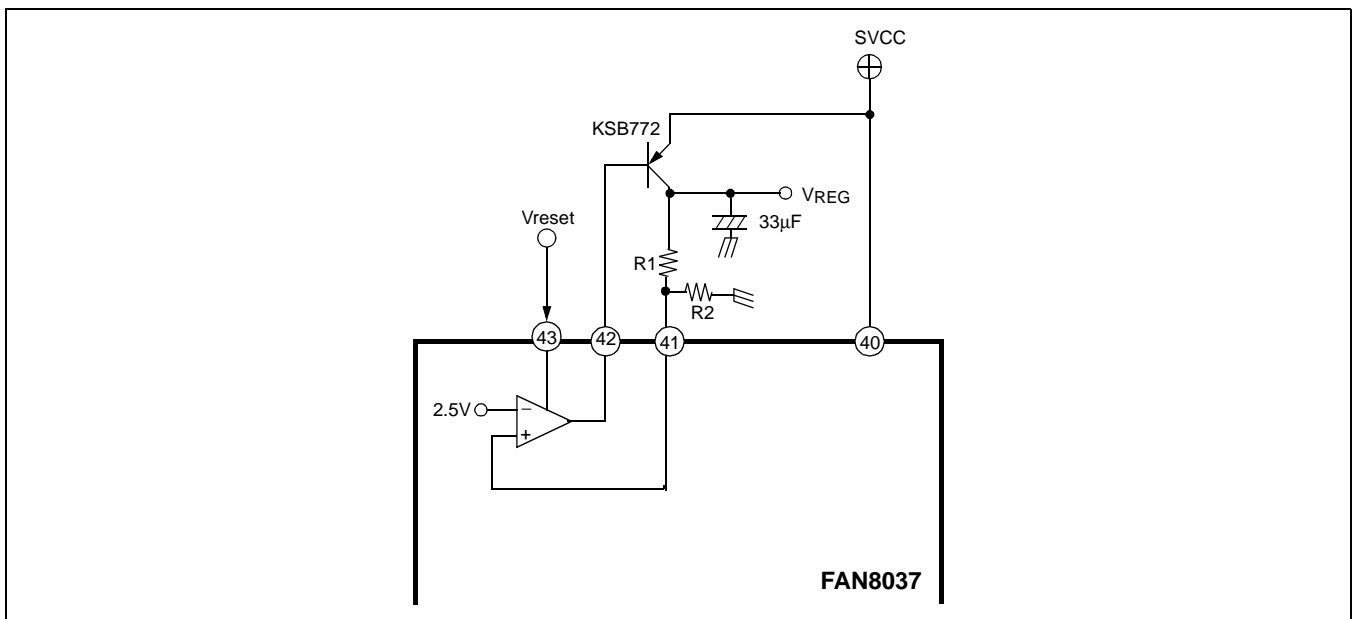
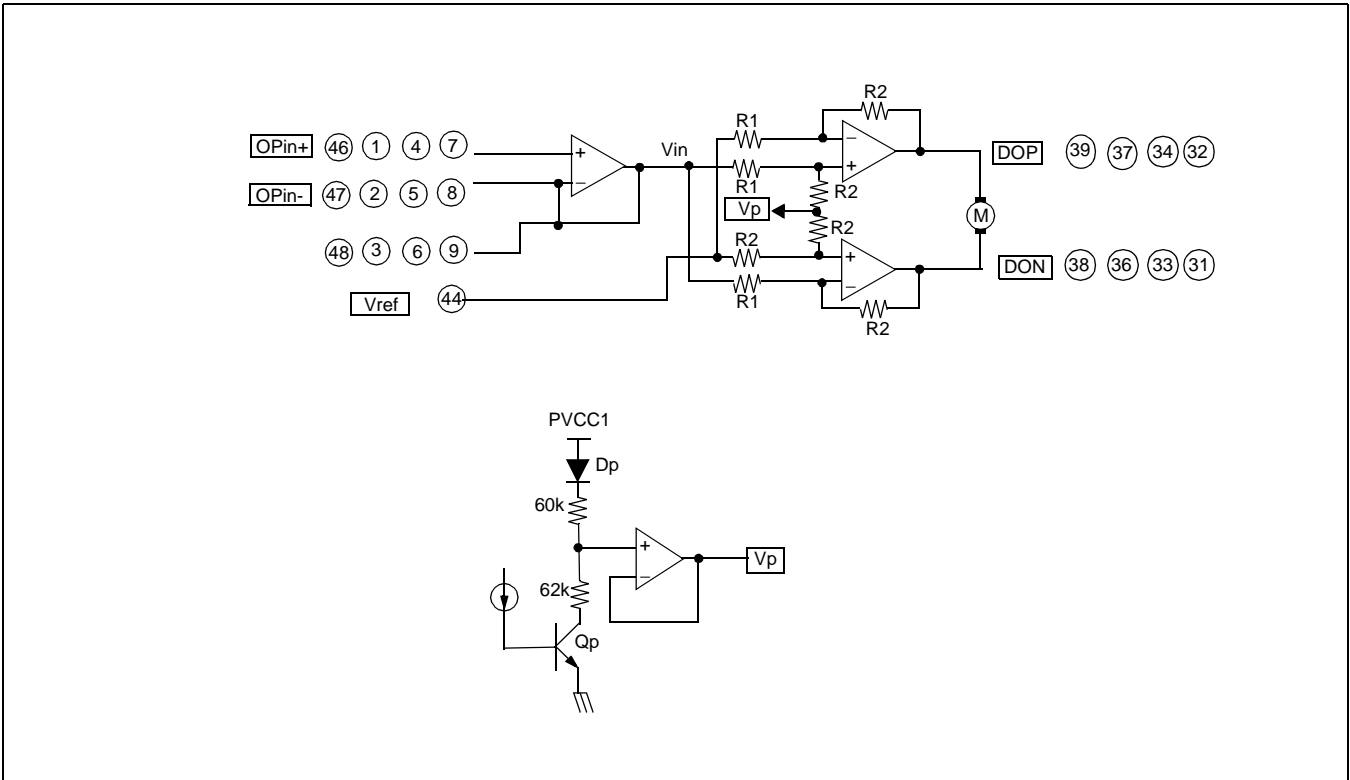

Figure 1. Regulator circuit

6. FOCUS, TRACKING ACTUATOR, SPINDLE, SLED MOTOR DRIVE PART

DC MOTOR DRIVE IC



- The voltage, Vref is the reference voltage given by the external bias voltage of the pin 44.
- The input signal (Vin) through pins 46,1,4 and 7 is amplified one time and then fed to the output stage. (assume that input opamp was used as a buffer)
- The total closed loop voltage gain is as follows

$$V_{in} = V_{ref} + \Delta V$$

$$DOP = V_p + 2\Delta V$$

$$DON = V_p - 2\Delta V$$

$$V_{out} = DOP - DON = 4\Delta V$$

$$Gain = 20 \log \frac{V_{out}}{\Delta V} = 20 \log 4 = 12 \text{dB}$$

- If you want to change the total closed loop voltage gain, you must use the input opamp as an amplifier
- The output stage is the balanced transformerless (BTL) driver.
- The bias voltage Vp is expressed as ;

$$\begin{aligned}
 V_p &= (PVCC1 - VDp - V_{cesatQp}) \times \frac{62k}{60k + 62k} + V_{cesatQp} \\
 &= \frac{PVCC1 - VDp + V_{cesatQp}}{1.97} + V_{cesatQp} \quad \text{----- (1)}
 \end{aligned}$$

7. TRAY, CHANGER,PANEL MOTOR DRIVE PART

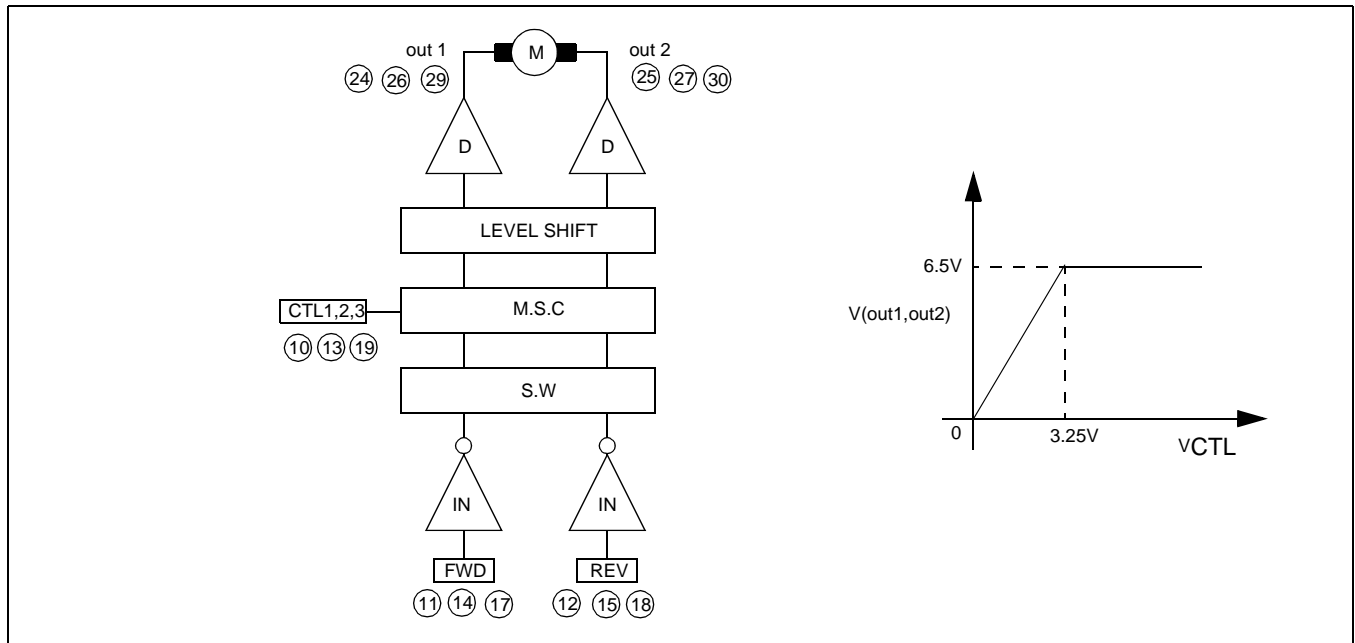

- Rotational direction control  
The forward and reverse rotational direction is controlled by FWD (pin 11,14, 17) and REV (pin 12,15,18) and the input conditions are as follows.

INPUT		OUTPUT		
FWD	REV	OUT 1	OUT 2	State
H	H	Vp	Vp	Brake
H	L	H	L	Forward
L	H	L	H	Reverse
L	L	-	-	High impedance

- Where Vp(Power referenced voltage) is approximately about 3.75V at PVCC2=8V ) according to equation (1).
- Where out1 pins are pins24,26,29 and out2 pins are pins25,27,30
- Motor speed control (When SVCC=PVCC2=8V)
  - The almost maximum torque is obtained when the pins (10,13 and 19 (CTL1, 2, 3)) are open.
  - If the voltage of the pins (10,13 and 19 (CTL1, 2, 3)) are 0V, the motor will not operate.
  - When the control voltage of the pins 10,13 and 19 (CTL1, 2, 3) are between 0 and 3.25V, the differential output voltage(V(out1,out2)) is about two times of control voltage. Hence, the control to the differential output gain is two.
  - When the control voltage is greater than 3.25V, the output voltage is saturated at the 6.5V because of the output swing limitation.

### 8. BOOTSTRAPPED OPERATION

- Our IC has two kinds of power supplies, the power supply , SVCC is for predrivers and the other circuit blocks(SVCC), and PVCC1 and PVCC2 is for the power transistors.
- When  $SVCC = PVCC_n$  ( $n=1,2$ ), no bootstapped operation occurs. Thus the single-ended maximum output voltage is about to

$$SVCC - (V_{cesatQ3} + V_{be1}) \cong SVCC - 1V$$

- If larger output swing is required, use the bootstrap function. When  $SVCC > PVCC_n + 1V$  the bootsrap function is operated.
- In the mode, the single-ended maximum output voltage is about to  $PVCC_n - V_{cesatQ1} \cong PVCC_n - 0.5$  ; hence wide output dynamic range can be obtained.

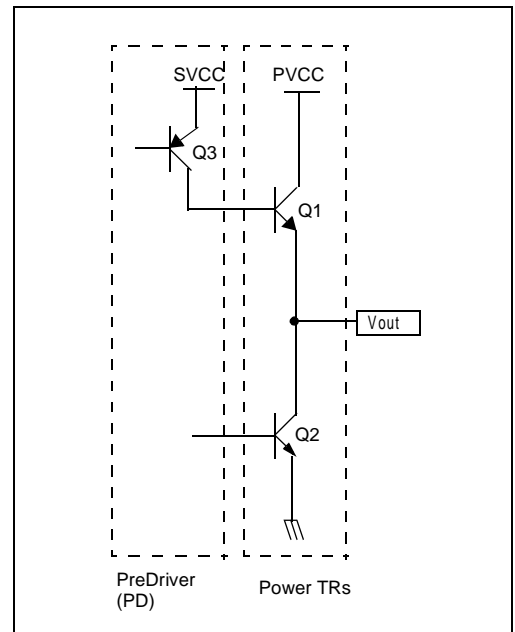



# Typical Application Circuits 1

[Voltage control mode]

# DC MOTOR DRIVE IC

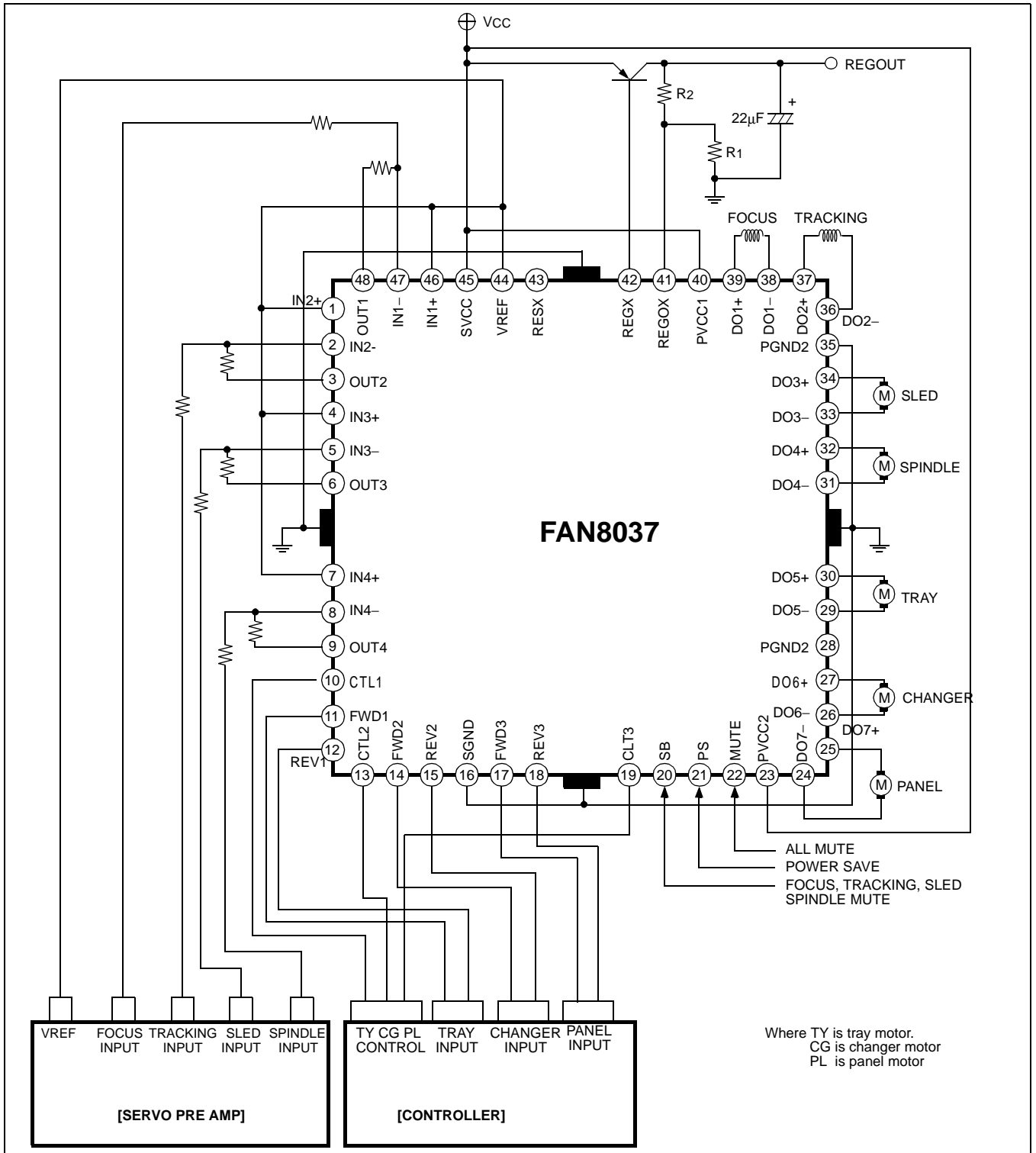

**Notes:**

Radiation pin is connected to the internal GND of the package.  
 Connect the pin to the external GND.

## Typical Application Circuits 2

[Differential PWM control mode ]

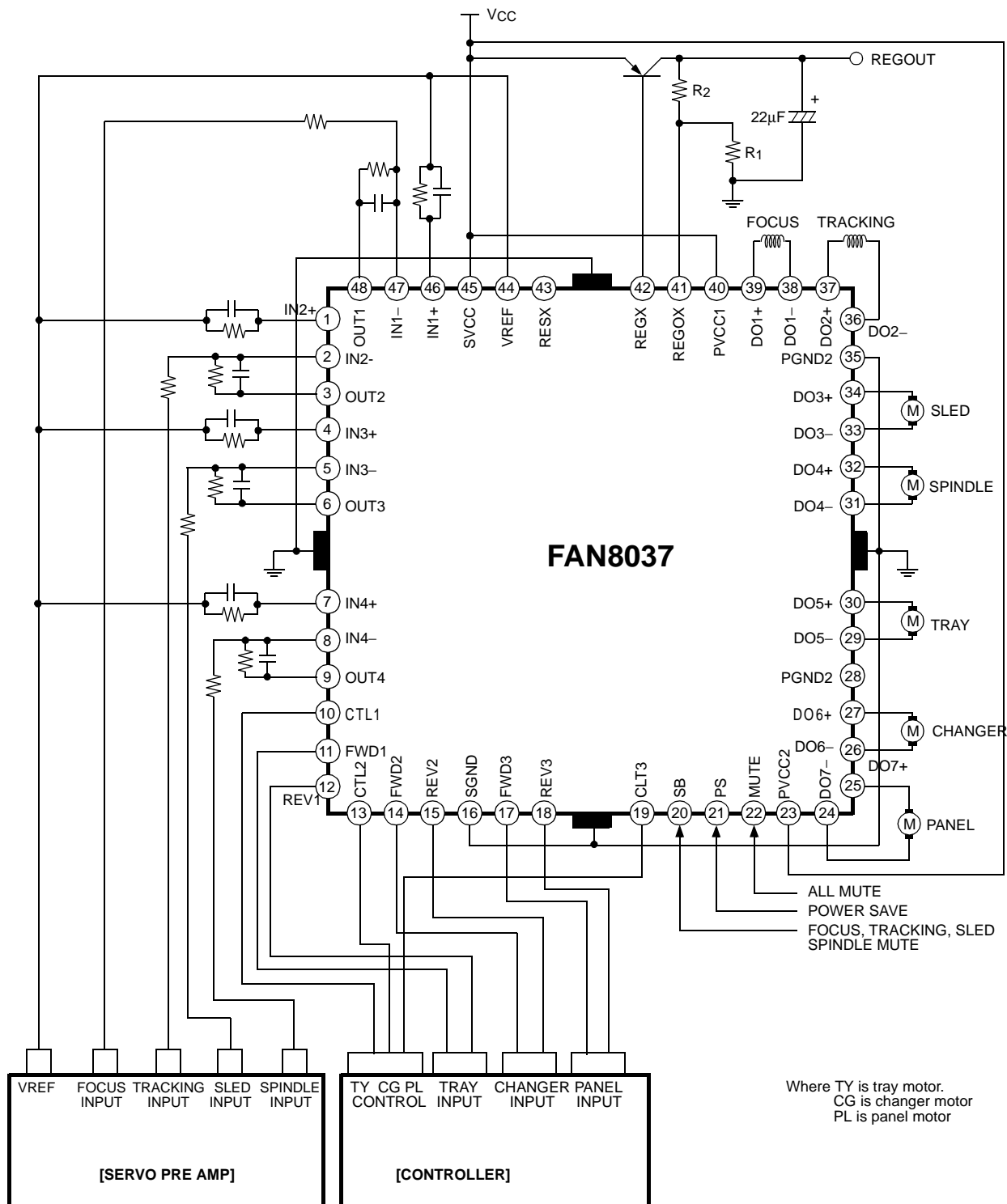

**Notes:**

Radiation pin is connected to the internal GND of the package.  
Connect the pin to the external GND

## Ordering Information

Device	Package	Operating Temperature
FAN80037	48-QFPH-1414	-35°C ~ +85°C

# DC MOTOR DRIVE IC

## LIFE SUPPORT POLICY

FAIRCHILD'S PRODUCTS ARE NOT AUTHORIZED FOR USE AS CRITICAL COMPONENTS IN LIFE SUPPORT DEVICES OR SYSTEMS WITHOUT THE EXPRESS WRITTEN APPROVAL OF THE PRESIDENT OF FAIRCHILD SEMICONDUCTOR CORPORATION. As used herein:

1. Life support devices or systems are devices or systems which, (a) are intended for surgical implant into the body, or (b) support or sustain life, and (c) whose failure to perform when properly used in accordance with instructions for use provided in the labeling, can be reasonably expected to result in a significant injury of the user.
2. A critical component in any component of a life support device or system whose failure to perform can be reasonably expected to cause the failure of the life support device or system, or to affect its safety or effectiveness.