

KA3050

Camera Motor Drivers and Controller

Features

- Built-in DC motor driver
: 1.5-CH DC motor driver : CW, CCW & Brake
- Stepping motor driver
- Built-in strobo control
- Built-in IRED driver for auto-focus
- Built-in VE selector
- Built-in VE voltage detector
- Built-in 5V regulator
- Built-in step-up DC/DC converter controller

Description

The KA3050 is a monolithic integrated circuit, and suitable for the motor driver (AE, AF, zoom and reel motor driver) and the controller (strobo trigger, IRED driver, supply voltage detector, step-up converter control, etc.) in camera systems.

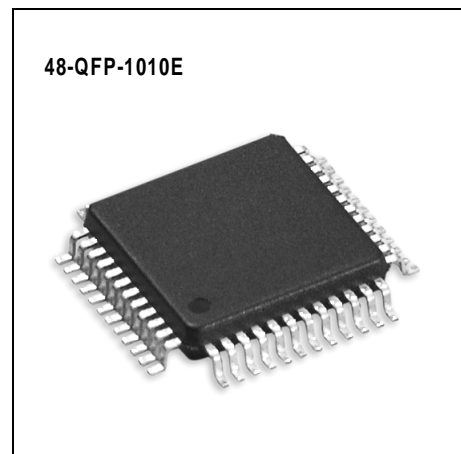

Typical Applications

- Auto focus camera
- Digital still camera

Pin Assignments

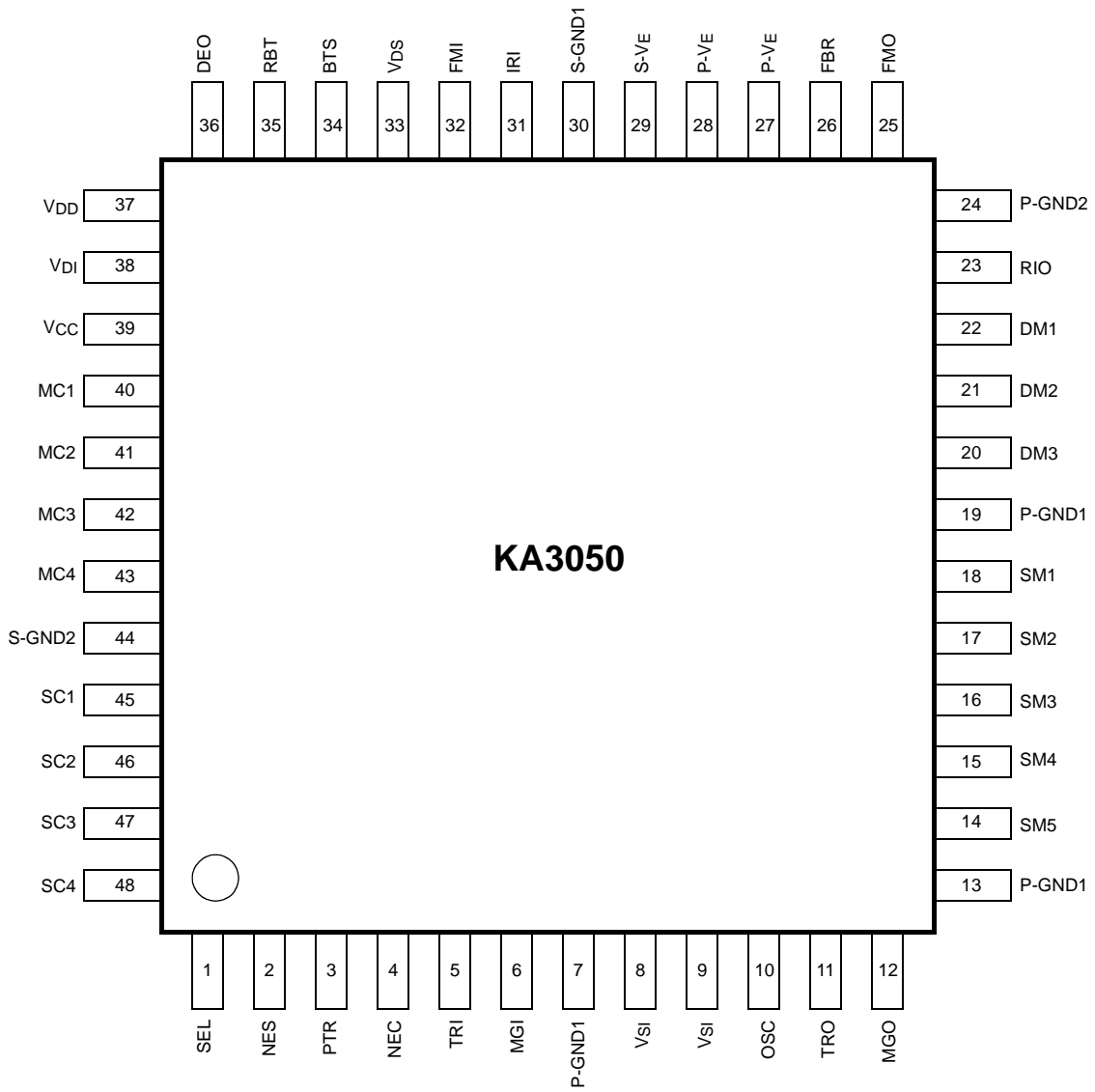

Pin Definitions

Pin Number	Pin Name	Pin Function Description
1	SEL	IC on/off
2	NES	Comparator input
3	PTR	PNP open collector output
4	NEC	PNP open collector output
5	TRI	Trigger input
6	MGI	Magnet drive input
7	P-GND1	Power ground 1
8	VSI	Step motor & AE meter power
9	VSI	Step motor & AE meter power
10	OSC	NPN open collector output
11	TRO	PNP open collector output
12	MGO	Magnet drive output (NPN open collector output)
13	P-GND1	Power ground 1
14	SM5	Step motor & AE meter output 5
15	SM4	Step motor & AE meter output 4
16	SM3	Step motor & AE meter output 3
17	SM2	Step motor & AE meter output 2
18	SM1	Step motor & AE meter output 1
19	P-GND1	Power ground 1
20	DM3	DC motor output 3
21	DM2	DC motor output 2
22	DM1	DC motor output 1
23	IRO	IREDD drive output
24	P-GND2	Power ground 2
25	FMO	Step-up converter switching output
26	FBR	IREDD feedback input
27	P-VE	Power VE (Battery power)
28	P-VE	Power VE (Battery power)
29	S-VE	Signal VE (Battery power)
30	S-GND1	Signal ground 1
31	IRI	IREDD control input
32	FMI	Step-up converter clock input
33	VDS	VDD selection (4V/5V)
34	BTS	Battery selection (3V/6V)
35	RBT	VE voltage detection output(analog)
36	DEO	VE voltage detection output(digital)
37	VDD	Inside power & outside power output
38	VDI	Step-up voltage
39	VCC	Motor drive IC power & control block power (5V) output
40	MC1	MC code input 1

Pin Definitions (Continued)

Pin Number	Pin Name	Pin Function Description
41	MC2	MC code input 2
42	MC3	MC code input 3
43	MC4	MC code input 4
44	MC5	Signal ground 2
45	SC1	SC code input 1
46	SC2	SC code input 2
47	SC3	SC code input 3
48	SC4	SC code input 4 / buffer output

Internal Block Diagram

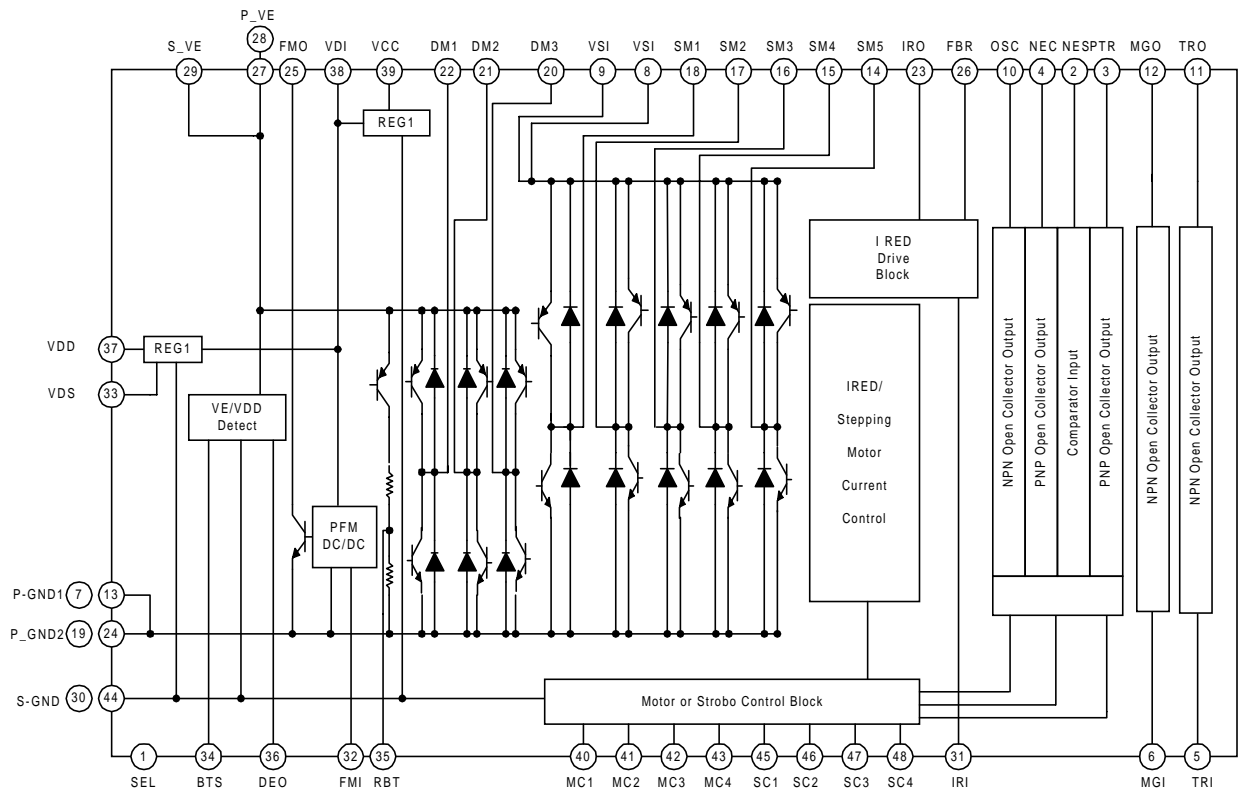

Equivalent Circuits

Description	Pin No.	Internal Circuit
1.5-Channel DC Motor Drive Block		
MC1~4	40~43	
SC1~4	45~48	
DM1	22	
DM2	21	
DM3	20	
P_VE	27,28	
P_GND	7, 13, 19, 24	
Stepping Motor Drive Block		
MC1~4	40~43	
SC1~4	45~48	
SM1	18	
SM2	17	
SM3	16	
SM4	15	
SM5	14	
VSI	8, 9	
P_GND	7, 13, 19, 24	
IRED Drive Block		
MC1~4	40~43	
SC1~4	45~48	
IRI	31	
IRO	23	
FBR	26	

Equivalent Circuits (Continued)

Description	Pin No.	Internal Circuit
Step-up Control Block		
FMI	32	
VDI	38	
FMO	25	
P_GND	7, 13, 19, 24	
General Buffer & Comparator Drive Block		
MC1~4	40~43	
SC1~3	45~47	
MGI	17	
MGO	16	
NES	2	
SC4	48	
TRI	5	
TRO	11	
PTR	3	
NEC	4	
OSC	10	
P_GND	7, 13, 19, 24	

CAMERA ONE CHIP DRIVE IC

Absolute Maximum Ratings (Ta = 25°C)

Parameter	Symbol	Value	Unit	Remark
Supply voltage	VE	-0.3 ~ +7.5	V	
Output current (VDD)	IVDD	80	mA	
Output current (VCC)	IVCC	50	mA	
Output current (Stepping motor)	ISM1, 2, 3, 4	500	mA	Within 70ms
Output current (AE meter)	ISM4, 5	1000	mA	Within 70ms
Current (DC motor)	IDM	3000	mA	Within 10ms
Output current (IRO)	IIRO	2000	mA	Within 500μs
Output current (MGO)	IMGO	500	mA	Within 200ms
Output terminal voltage	VOUT	-0.3 ~ +7.5	V	
Input terminal voltage	VIN	-0.3 ~ +7.5	V	
Power dissipation	PD	1.0	W	
Operating temperature range	TOPR	-20 ~ +50	°C	
Storage temperature	TSTG	-55 ~ +125	°C	

Power Dissipation Curve

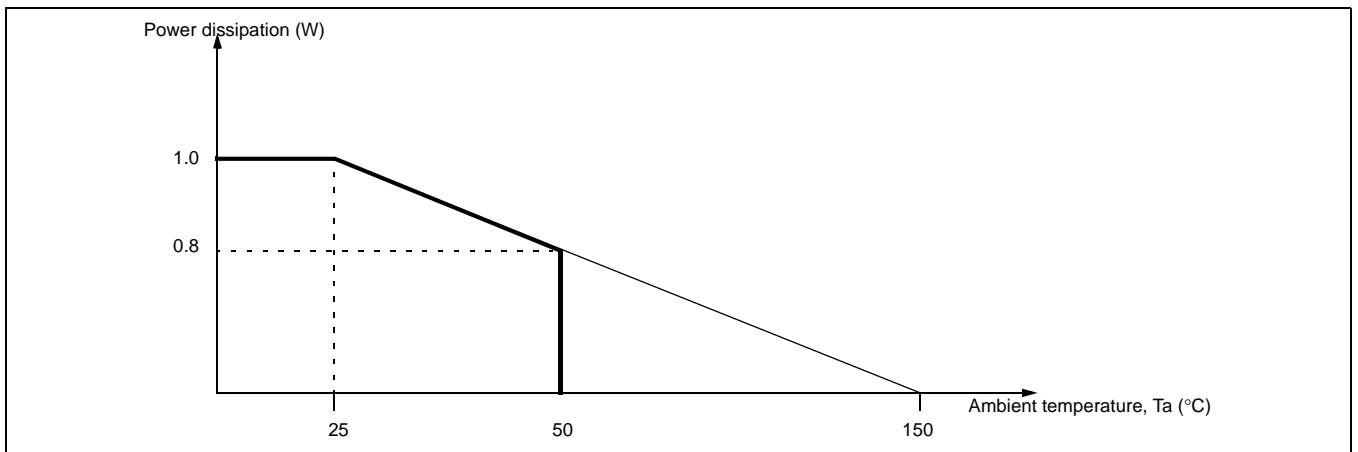

Recommended Operating Conditions (Ta = 25°C)

Parameter	Symbol	Min.	Typ.	Max.	Unit
Operating supply voltage	VE	2.0	-	7.5	V

Electrical Characteristics (Ta = 25°C)

Block	Parameter	Symbol	Condition	Min.	Typ.	Max.	Units	Note
Total	Leakage current	ISTB	VE=6.0V	-	-	1.0	μA	1
	Low input voltage range	VINL	-	-0.3	-	0.6	V	2
	High input voltage range	VINH	-	1.6	-	7.0	V	3
	Control input current	I _{IH}	V _{IH} =4.0V	-	80	120	μA	4
I _{IL}		V _{IL} =GND	-1	-	0			
Step-up & VDD	Min. operating voltage	V _{MIN}	-	-	-	1.0	V	5
	Step-up output voltage 1	V _{VDI1}	VE=2.0V, I _{LOAD} =100mA	5.35	5.5	5.65	V	6
	Step-up output voltage 2	V _{VDI2}	VE=2.0V, I _{LOAD} =100mA	8.3	8.6	8.9		
	FMO output voltage 1	V _{VOL1}	VE=2.0V, I _{LOAD} =700mA	-	-	0.3	V	7
	FMO output voltage 2	V _{VOL2}	VE=2.0V, I _{LOAD} =1000mA	-	-	0.4		
	FMI step-up clock	f	VE=2.0V	39	156	313	KHz	8
	VDD output voltage 3	V _{VDD3}	I _O =80mA	3.85	4.0	4.15	V	9
	VDD output voltage 4	V _{VDD4}	I _O =80mA	4.85	5.0	5.15		
	Input & output potential difference 1	V _{SAT1}	I _O =80mA	-	-	0.3	V	10
	VDET	VE detection voltage (1-1)	V _{TH+1}	VE=6V	3.0	3.15	3.3	V
VE detection voltage (1-2)		V _{TH-1}	VE=6V	2.7	2.85	3.0		
VE detection voltage (2-1)		V _{TH+2}	VE=6V/3V	1.5	1.65	1.8	V	12
VE detection voltage (2-2)		V _{TH-2}	VE=6V/3V	1.2	1.35	1.5		
Output saturation voltage		V _{DEO}	VE=2.0V, I _{OL} =5mA	-	-	0.5	V	13
Operating voltage range 1		V _{OPR1}	VE	1.2	-	7.5	V	14
RBT	Stand-by output voltage	V _{SBT}	-	-	-	0.1	V	15
	Output voltage in operating	V _{RBT1}	I _{OL} =10μA	0.47	0.5	0.53	× VE	16
	Operating voltage range 2	V _{OPR2}	-	1.5	-	7.5	V	17
	Output voltage temperature coefficient	V _T	-	-	-	2.0	mV/°C	18
VCC	VCC output voltage	V _{VDD5}	I _O =50mA	4.85	5.0	5.15	V	19
	Input & output potential difference 2	V _{DAT2}	I _O =50mA, V _{CC} =3V	-	-	0.3	V	20
	Function compensation voltage range 3	V _{OPR3}	VE	1.0	-	7.5	V	21
DC MOTOR	Function compensation voltage range 4	V _{OPR4}	-	1.0	-	7.5	V	22
	Output voltage (PNP+NPN) 1	V _{DV1}	VE=2.0V, I _{OL} =800mA	-	0.6	0.8	V	23
	Output voltage (PNP+NPN) 2	V _{DV2}	VE=2.0V, I _{OL} =1000mA	-	0.8	1.0		

Electrical Characteristics (Continued)

Block	Parameter	Symbol	Condition	Min.	Typ.	Max.	Units	Note
S.M & AE METER	Function compensation voltage range 5	VOPR5	VSI=VE	1.6	-	7.5	V	24
	Output saturation voltage	VSTP	VSI=3.5V, IO=500mA	-	-	0.8	V	25
	Output voltage relative error	ΔV	IO=300mA, SMI1,2,3,4	-	-	0.1	V	26
	VCOIL voltage	VCOIL	VCC=5V	1.7	1.8	1.9	V	27
	VCOIL voltage STEP	VCOST	-	-	190	-	mV	
STROBO	Function compensation voltage range 6	VOPR6	-	1.0	-	7.5	V	28
	TRO output voltage	VTRO	IO=10mA	-	-	0.5	V	29
	PTR output voltage	VPTR	IO=10mA	-	-	0.5	V	30
	NEC output voltage	VNEC	IO=10mA	-	-	0.5	V	31
	OSC output voltage	VOSC	IO=10mA	-	-	0.5	V	32
	NES detection voltage	VNES	-	0.27	0.3	0.33	$\times V_{DD}$	33
	SC4 "L" level	VSOL	-	-	-	0.3	V	34
	SC4 "H" level	VSOH	-	0.8	-	-	$\times V_{DD}$	35
IRED	Output saturation voltage 3	VSAT3	IOL=1A	-	-	1.0	V	36
	Output current	IO	RFBR=0.25 Ω VFBR=200mV	0.72	0.8	0.88	A	37
	Operating voltage range	VOP	-	1.5	-	7.5	V	38
MG	MGI detection voltage	VMGI	-	0.22	0.25	0.28	$\times V_{CC}$	39
	MGO output saturation voltage	VMGO	IO=500mA	-	-	0.5	V	40

Electrical Characteristics (Continued)

Notes:

1. Define Input Current at Stand-By.
2. Define Low Level of Input Terminals.
3. Define High Level of Input Terminals.
4. Define Input Current of Each Control Input Terminals.
5. Define Min. Operating Voltage for Step-up Circuits (SEL, FMO)
6. Define Output Voltage of VDD at Step-up.
7. Define Saturation Voltage of FMO Output.
8. Define Frequency of Step-up Clock.
9. Define Output Voltage of VDD.
10. Define Input and Output Potential Difference of VDD Regulator.
11. Define Detection Voltage of V_E Detection Circuit. (with Hysteresis, Using 6V Battery)
12. Define Detection Voltage of V_E Detection Circuit. (with Hysteresis, Using 6V or 3V Battery)
13. Define Output Saturation Voltage of DEO.
14. Define Operating Voltage Range of V_E Detection Circuit.
15. Define Output Voltage at Stand-by.
16. Define RBT Output Voltage at Operating RBT Circuit.
17. Define Operating Voltage Range of RBT Circuit.
18. Define Temperature Coefficient of RBT Output Voltage.
19. Define V_{CC} Output Voltage at Connecting V_{SI} and V_E .
20. Define Input and Output Potential Difference of V_{CC} Regulator.
21. Define Function Compensation Voltage of V_{CC} Output Circuit.
22. Define Function Compensation Voltage of DC Motor Driving Circuit.
23. Define Output Saturation Voltage (PNP + NPN) of DC Motor Driving Circuit.
24. Define Function Compensation Voltage of Stepping Motor and AE Meter Driving Circuit.
25. Define Output Saturation Voltage (PNP + NPN) at Flowing Specified Current.
26. Define Relative Error of Output Voltage at Flowing Specified Current between SM1-2 and SM3-4.
27. Define Voltage between Both Side of V_{COIL} .
28. Define Function Compensation Voltage of Strobo Control Circuit.
29. Define Output Saturation Voltage of TRO.
30. Define Output Saturation Voltage of PTR.
31. Define Output Saturation Voltage of NEC.
32. Define Output Saturation Voltage of OSC.
33. Define Detection Voltage of NES Voltage Detection Circuit.
34. Define Low Level of SC4.
35. Define High Level of SC4.
36. Define Output Saturation Voltage of IRED Driving Circuit.
37. Define Output Current of IRO.
38. Define Operating Voltage Range of IRED Driving Circuit.
39. Define Detection Voltage of MGI.
40. Define Output Saturation Voltage at Flowing Specified Current of MGO.

Application Information

1. ZOOM AND REEL MOTOR DRIVE BLOCK (1.5-CHANNEL DC MOTOR DRIVE BLOCK)

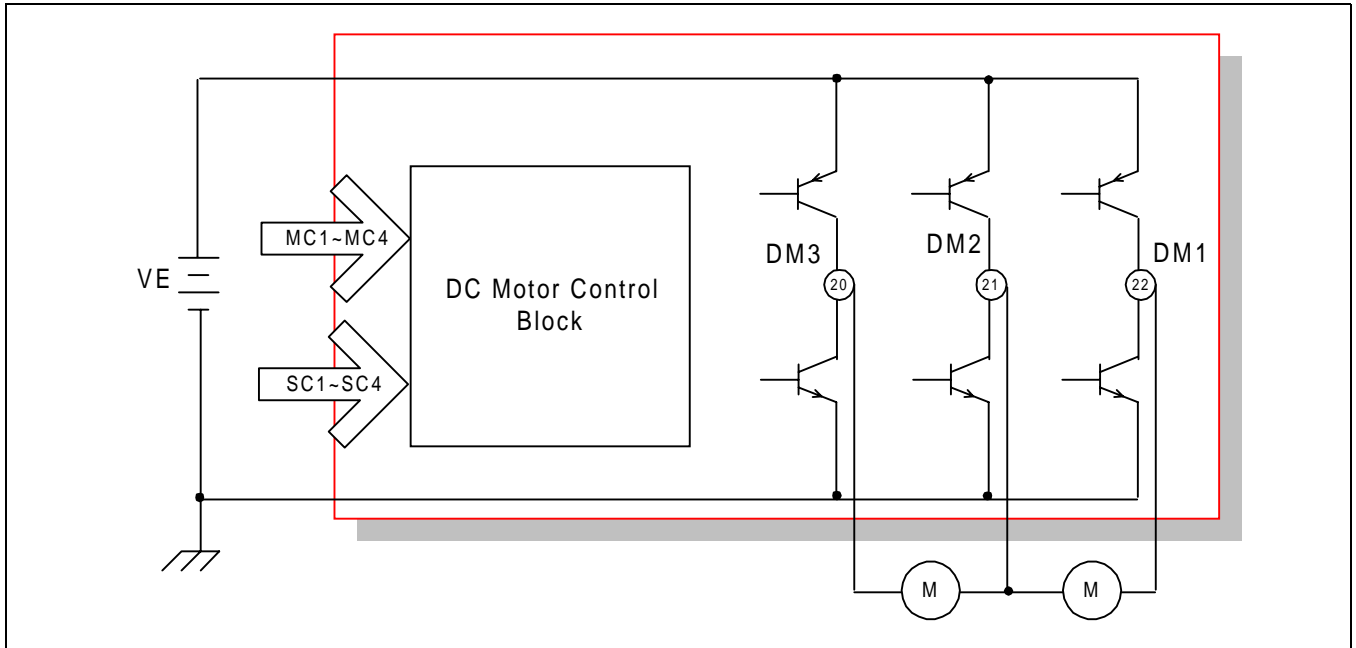

This block diagram describes the driver of zoom and reel motor in camera systems.

The drive block is controlled by MC1~4 and SC1~4, which are come from micro controller.

Follow is the control logic table.

INPUT								OUTPUT		
MC1	MC2	MC3	MC4	SC1	SC2	SC3	SC4	DM1	DM2	DM3
L	L	L	H	L	L	L	L	L	H	
	L	H	L					H	L	
	L	H	H					L	L	
	H	L	H						H	L
	H	H	L						L	H
	H	H	H						L	L

2. AF MOTOR AND AE METER DRIVE BLOCK (STEPPING MOTOR DRIVE BLOCK)

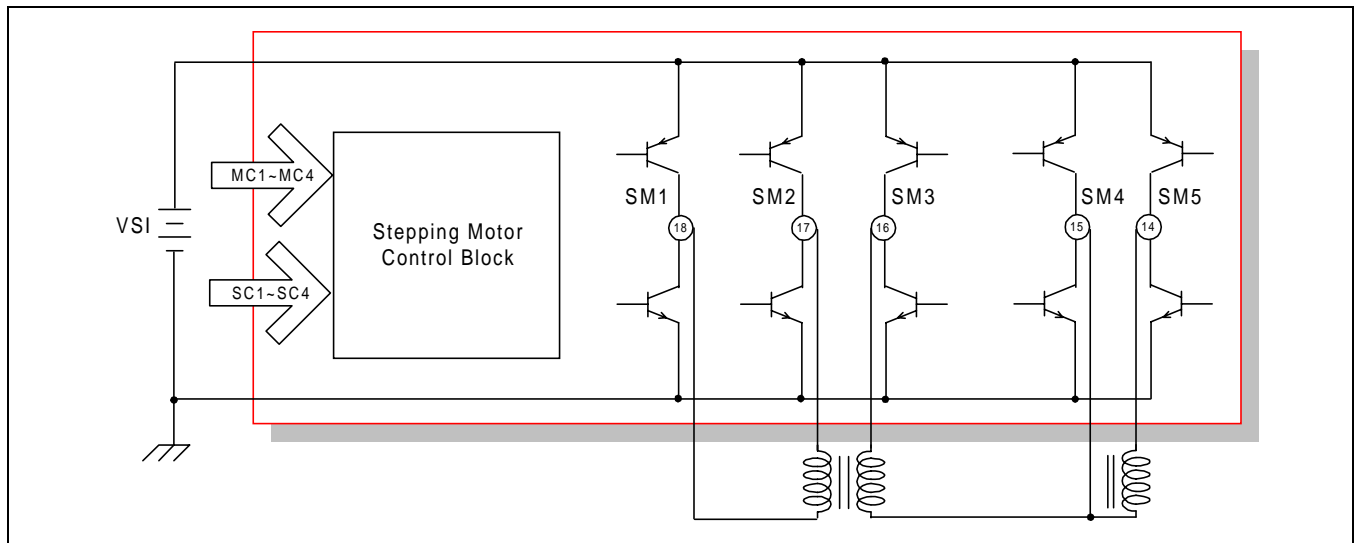

The block diagram describes the driver of AF motor and AE meter in camera systems.

The drive output is selected by MC signals (MC1~4).

These MC codes are as follows.

INPUT				OUTPUT				
MC1	MC2	MC3	MC4	SM1	SM2	SM3	SM4	SM5
H	L	L	H				L	H
	L	H	L				H	L
	L	H	H				L	L
	H	L	L	L	H	L	H	
	H	L	H	L	H	H	L	
	H	H	L	H	L	L	H	
	H	H	H	H	H	L	H	L

The output voltage (VCOIL) is determined by SC1~4.

The VCOIL is potential difference between drive output and ground.

i.e.,

$$V_{COIL} = V_{SM} - GND.$$

The VCOIL is selected by following table.

INPUT				V _{COIL} OUTPUT VOLTAGE [V]
SC1	SC2	SC3	SC4	
L	L	L	L	1.80
L	L	L	H	1.99
L	L	H	L	2.18
L	L	H	H	2.37
L	H	L	L	2.56
L	H	L	H	2.75
L	H	H	L	2.94
L	H	H	H	3.13
H	L	L	L	3.32
H	L	L	H	3.51
H	L	H	L	3.70
H	L	H	H	3.89
H	H	L	L	4.08
H	H	L	H	4.27
H	H	H	L	4.46
H	H	H	H	4.65

3. IRED DRIVE BLOCK

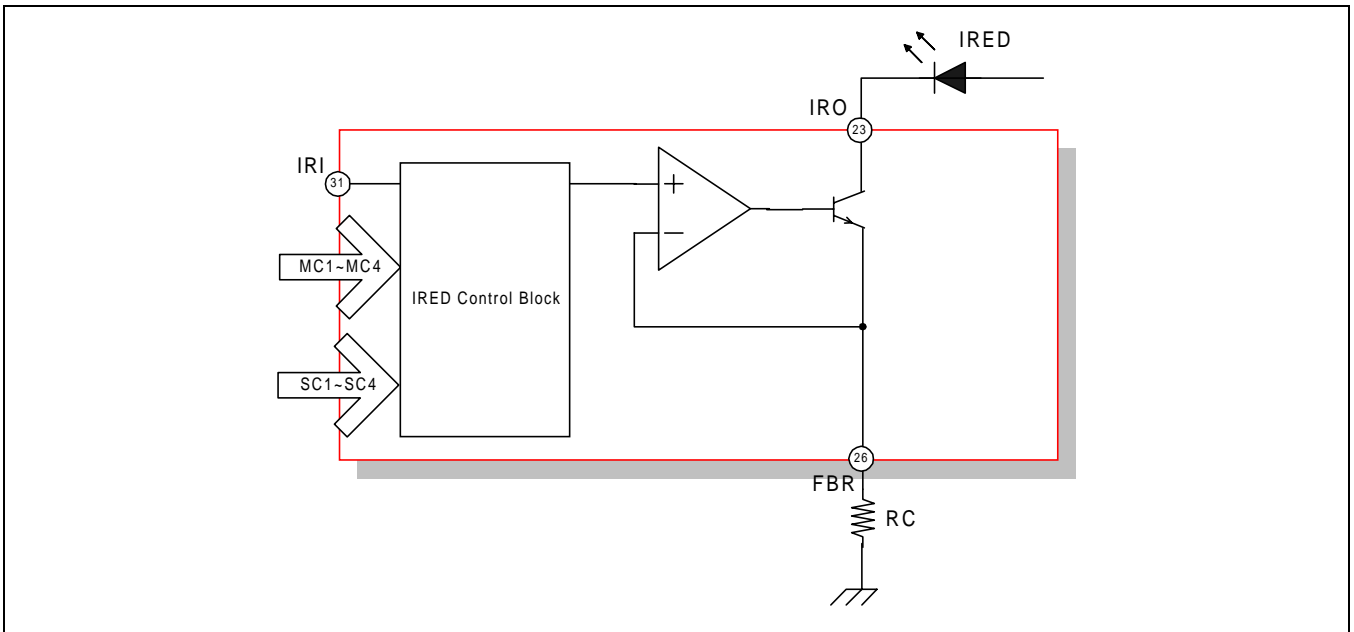

The block drives infrared emitting diode (IRED).

The FBR voltage (VFBR) is controlled by MC codes and SC codes.

The IRED current (IRED) is determined by VFBR and resistor Rc.

i.e.,

$$I_{RED} = V_{FBR} / R_C$$

The VFBR is controlled as following table.

INPUT								VFBR [mV]
MC1	MC2	MC3	MC4	SC1	SC2	SC3	SC4	
L	H	L	L	L	L	L	L	190
				L	L	L	H	210
				L	L	H	L	230
				L	L	H	H	250
				L	H	L	L	270
				L	H	L	H	290
				L	H	H	L	310
				L	H	H	H	330
				H	L	L	L	350
				H	L	L	H	370
				H	L	H	L	390
				H	L	H	H	410
				H	H	L	L	430
				H	H	L	H	450
				H	H	H	L	470
				H	H	H	H	490

4. STEP-UP CONTROL BLOCK

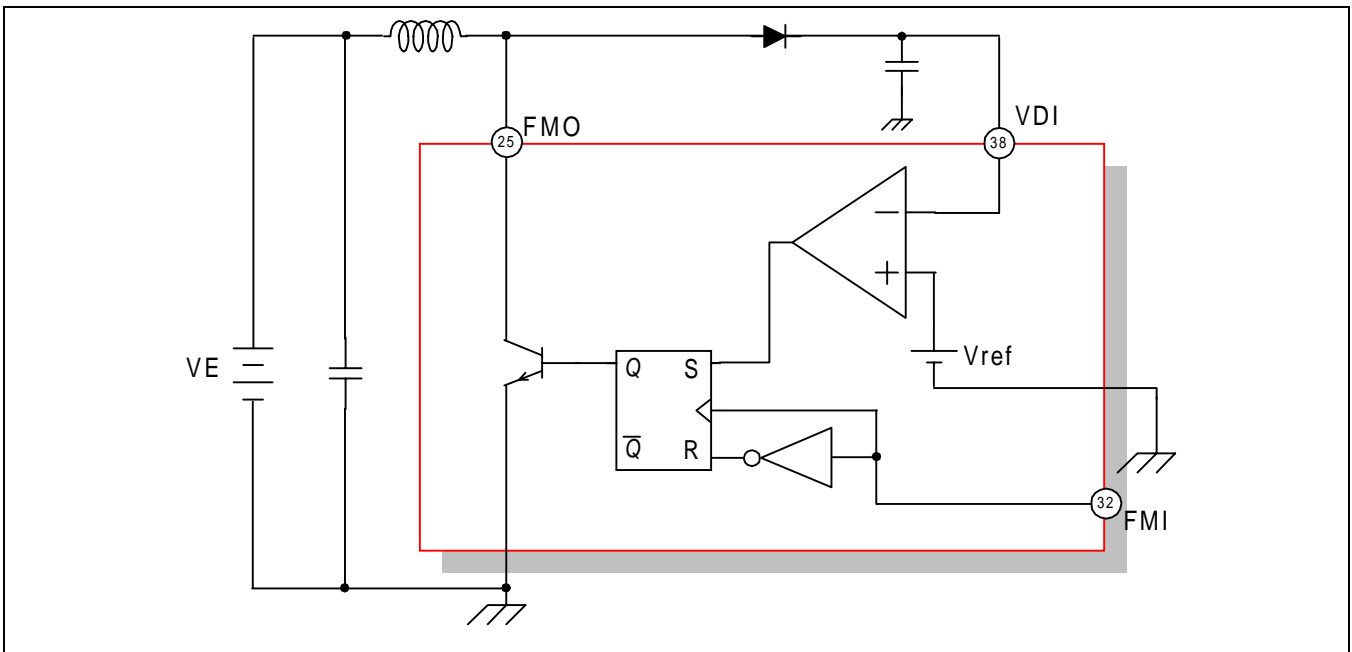

The FMO frequency from KA3050 steps up the battery voltage V_E .

The FMO frequency depends on the FMI frequency, which is come from micro controller.

Maximum value of VDI is 5.5V in normal operation mode, and 8.6V in IRED operation mode.

i.e.,

Normal Operation Mode: $V_{DI} = 5.5V$

IRED Operation Mode: $V_{DI} = 8.6V$

5. GENERAL BUFFER AND COMPARATOR DRIVE BLOCK

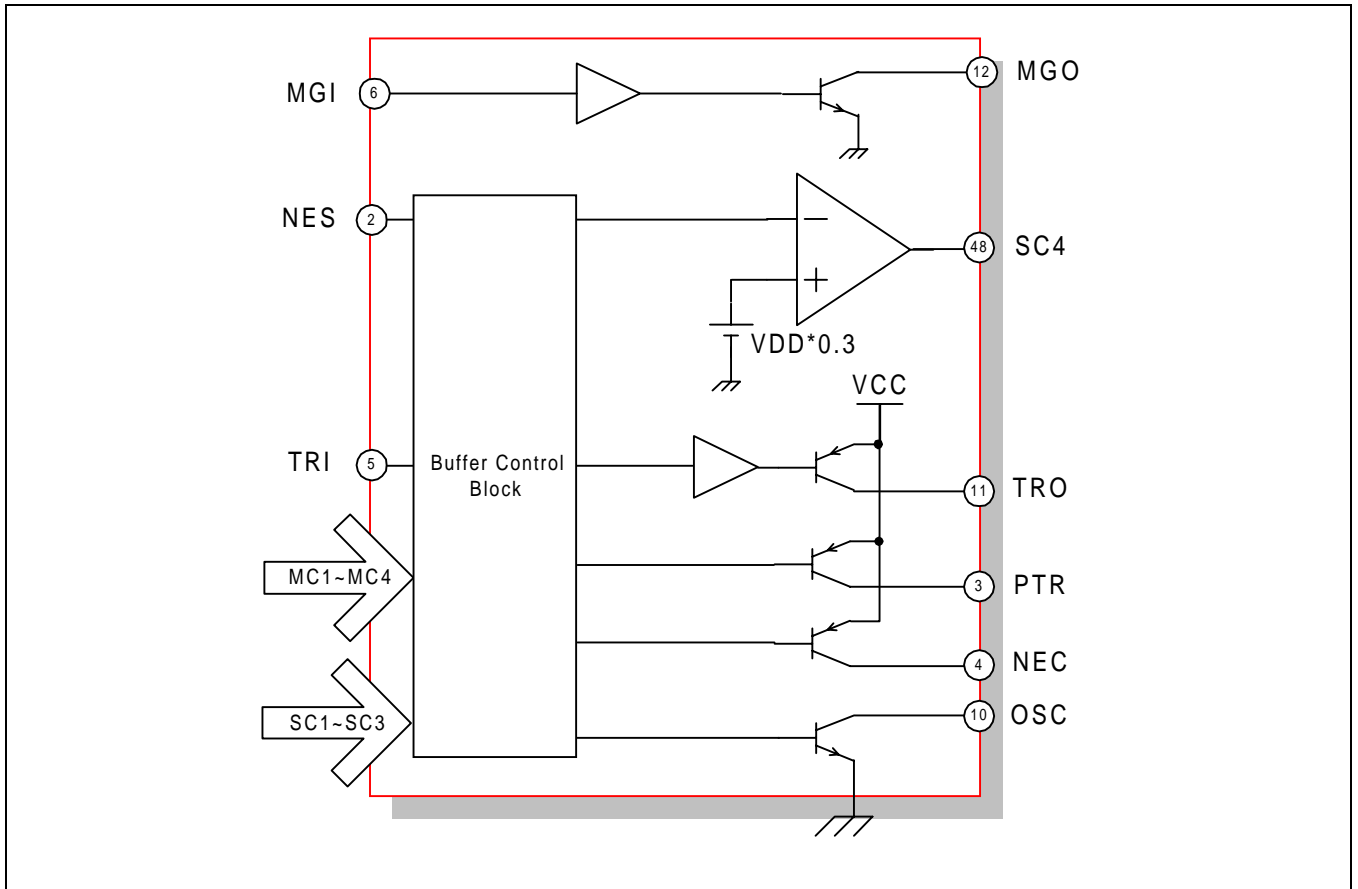

The KA3050 is composed of 5 general buffers and a comparator.

This block has 10 inputs and 6 outputs.

All output are controlled by MC and SC codes except MGO.

The control codes are as follows.

INPUT									OUTPUT				
MC1	MC2	MC3	MC4	SC1	SC2	SC3	NES	TRI	SC4	OSC	NEC	PTR	TRO
L	L	L	L	L	L	H	H/L		L/H		H		
				L	H	L	H/L		L/H	L	H		
				L	H	H				L			
				H	L	L		H/L				H	H/ OPEN

The NES and SC4 are conflict with each other, it means.

NES = High → SC4 = Low

NES = Low → SC4 = High

The meaning of H/L in TRI signal and H/OPEN in TRO signal are as follows.

TRI = High → SC4 = High

TRI = Low → SC4 = Open

The OSC signal refer to following table.

VDET1	DEO(VDET2)	BTS	OSC	STEP-UP CIRCUIT
H		Open(6V)	Enable	Enable
L	H		Disable	Enable
	L		Disable	Disable
	H	Ground(3V)	Enable	Enable
	L		Disable	Disable

Where,

DEO: Battery Voltage Checker, Pin 36

BTS: Battery Selector, Pin 34

Users can't check the VDET1 because VDET1 is selected automatically inside the KA3050 in 6V battery usage.

But step-up circuit (SUC) can be checked by DEO signal.

The VDET1 and DEO have hysteresis loop as following graph.

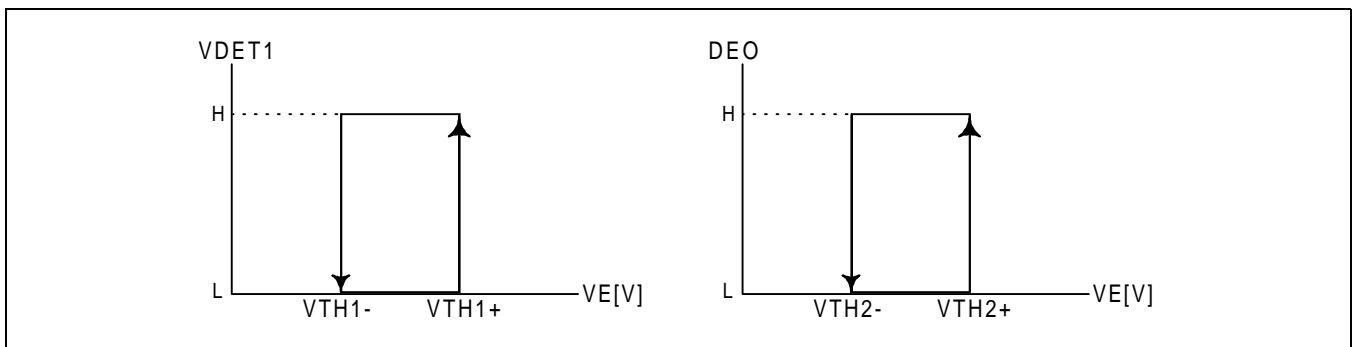

The VTH1 and VTH2 refer to electrical characteristics.

6. OTHER CONTROL BLOCKS

The following table is description of other control blocks.

Pin No.	Symbol	Function
1	SEL	High: KA3050 Operation
		Low: KA3050 No Operation
33	VDS	Open: $V_{DD} = 5V$
		Ground: $V_{DD} = 4V$
34	BTS	Open: $V_E = 6V$
		Ground: $V_E = 3V$
35	RBT	$VRBT = V_E / 2$
36	DEO	High: Sufficient Battery
		Low: Insufficient Battery
37	VDD	4V or 5V Regulator output
39	VCC	5V Regulator output

Control Code Table

MC1	MC2	MC3	MC4	SC1	SC2	SC3	SC4	DM1	DM2	DM3	SM1	SM2	SM3	SM4	SM5	OSC	NEC	PTR	NES	TR1	TR0	FBR	VCO					
L	L	L	L																									
L	L	L	H	L	L	L	L	L	H																			
L	L	H	L					H	L																			
L	L	H	H					L	L																			
L	H	L	L	CODE																								
L	H	L	H						H	L																		
L	H	H	L	L	L	L	L		L	H																		
L	H	H	H						L	L																		
H	L	L	L	CODE																								
H	L	L	H														L	H										
H	L	H	L														H	L										
H	L	H	H														L	L										
H	H	L	L											L	H	L	H											
H	H	L	H											L	H	H	L											
H	H	H	L											H	L	L	H											
H	H	H	H											H	L	H	L											
L	L	L	L					L	L	H	*1										H		H/L					
L	L	L	L					L	H	L	*1									L	H		H/L					
L	L	L	L	L	H	H	*1									L												
L	L	L	L	H	L	L	*1											H		H/L	H/OPEN							
L / H	H / *	L / *	L / *	L	L	L	L								FBR 190mV				VCOIL 1.80V									
				L	L	L	H							210mV						1.99V								
				L	L	H	L										230mV				2.18V							
				L	L	H	H										250mV				2.37V							
				L	H	L	L										270mV				2.56V							
				L	H	L	H										290mV				2.75V							
				L	H	H	L										310mV				2.94V							
				L	H	H	H										330mV				3.13V							
				H	L	L	L										350mV				3.32V							
				H	L	L	H										370mV				3.51V							
				H	L	H	L										390mV				3.70V							
				H	L	H	H										410mV				3.89V							
				H	H	L	L										430mV				4.08V							
				H	H	L	H										450mV				4.27V							
				H	H	H	L										470mV				4.46V							
H	H	H	H										490mV				4.65V											

Notes: * mark : Detect NES signal and send a inverted signal to SC4.

Test Circuits

CAMERA ONE CHIP DRIVE IC

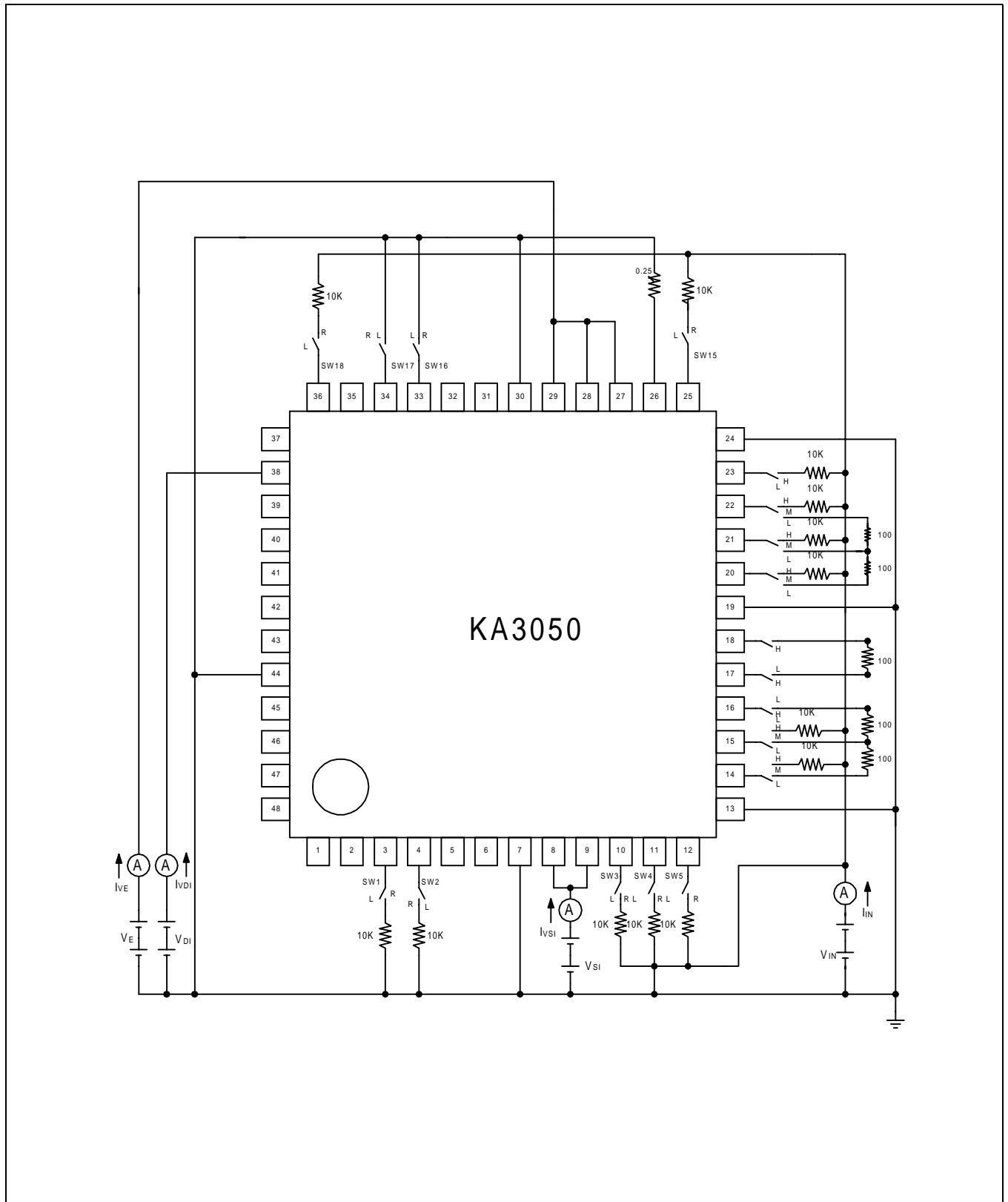

Typical Application Circuits

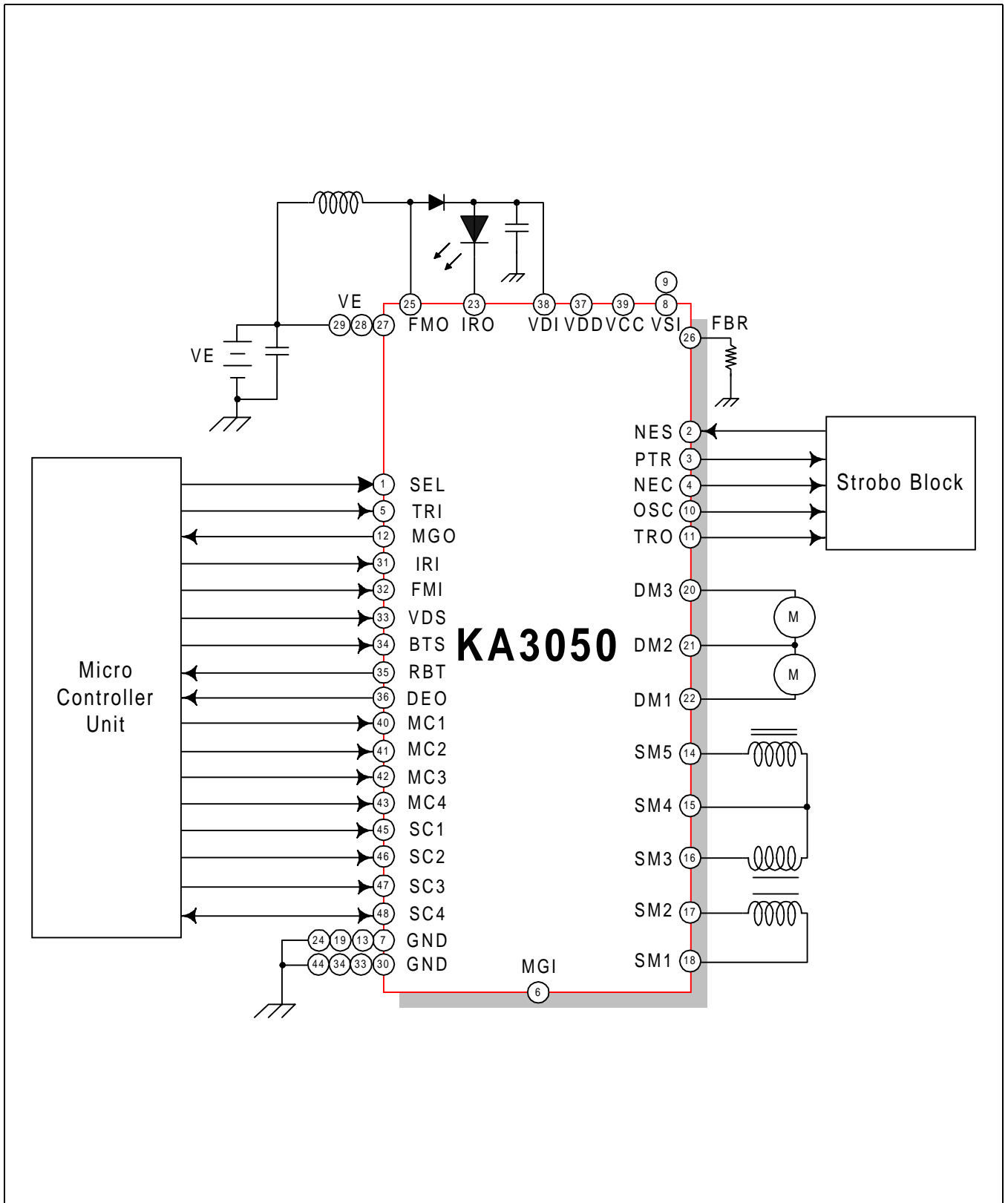

Ordering Information

Device	Package	Operating Temperature
KA3050	48-QFP-1010E	-20°C ~ +50°C

CAMERA ONE CHIP DRIVE IC

CAMERA ONE CHIP DRIVE IC

LIFE SUPPORT POLICY

FAIRCHILD'S PRODUCTS ARE NOT AUTHORIZED FOR USE AS CRITICAL COMPONENTS IN LIFE SUPPORT DEVICES OR SYSTEMS WITHOUT THE EXPRESS WRITTEN APPROVAL OF THE PRESIDENT OF FAIRCHILD SEMICONDUCTOR CORPORATION. As used herein:

1. Life support devices or systems are devices or systems which, (a) are intended for surgical implant into the body, or (b) support or sustain life, and (c) whose failure to perform when properly used in accordance with instructions for use provided in the labeling, can be reasonably expected to result in a significant injury of the user.
2. A critical component in any component of a life support device or system whose failure to perform can be reasonably expected to cause the failure of the life support device or system, or to affect its safety or effectiveness.