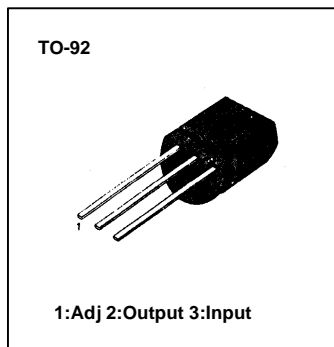

3-TERMINAL 0.1A POSITIVE ADJUSTABLE REGULATOR

The LM317L is a 3-terminal adjustable positive voltage regulator capable of supplying in excess of 100mA over an output voltage range of 1.2V to 37V. This voltage regulator is exceptionally easy to use and requires only two external resistors to set the output voltage.

**FEATURES**

- Output current in excess of 100mA
- Output adjustable between 1.2V and 37V
- Internal thermal-overload protection
- Internal short-circuit current-limiting
- Output transistor safe-area compensation
- Floating operation for high-voltage applications

ORDERING INFORMATION

Device	Package	Operating Temperature
LM317LZ	TO-92	0 ~ 125°C

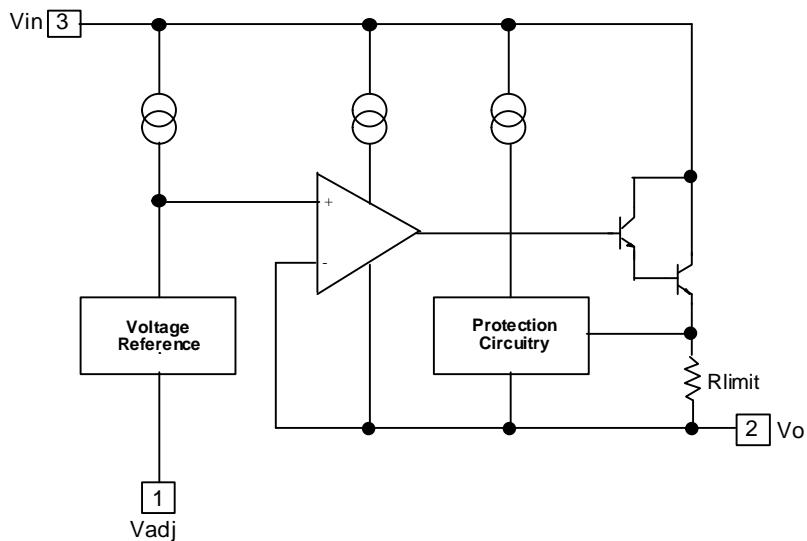
BLOCK DIAGRAM

LM317L (KA317) ADJUSTABLE VOLTAGE REGULATOR (POSITIVE)

ABSOLUTE MAXIMUM RATINGS

Characteristic	Symbol	Value	Unit
Input-Output Voltage Differential	$V_I - V_O$	40	V
Power Dissipation	P_D	Internally limited	W
Operating Temperature Range	T_{OPR}	0 ~ +125	°C
Storage Temperature Range	T_{STG}	-65 ~ +125	°C

ELECTRICAL CHARACTERISTICS

($V_I - V_O = 5V$, $I_O = 40mA$, $0^\circ C \leq T_J \leq +125^\circ C$, $P_{DMAX} = 625mW$, unless otherwise specified)

Characteristic	Symbol	Test Conditions	Min	Typ	Max	Unit
*Line Regulation	ΔV_O	$T_A = +25^\circ C$ $3V \leq V_I \leq V_O \leq 40V$ $3V \leq V_I \leq V_O \leq 40V$		0.01 0.02	0.04 0.07	%/V
*Load Regulation	ΔV_O	$T_A = +25^\circ C$ $10mA \leq I_O \leq 100mA$ $V_O \leq 5V$ $V_O \geq 5V$ $10mA \leq I_O \leq 100mA$ $V_O \leq 5V$ $V_O \geq 5V$		5 0.1 20 0.3	25 0.5 70 1.5	mV %/ V_O mV %/ V_O
Adjustment Pin Current	I_{ADJ}			50	100	μA
Adjustment Pin Current Change	ΔI_{ADJ}	$3V \leq V_I - V_O \leq 40V$ $10mA \leq I_O \leq 100mA$ $P_D < P_{DMAX}$		0.2	5	μA
Reference Voltage	V_{REF}	$3V < V_I - V_O < 40V$ $10mA \leq I_O \leq 100mA$ $P_D \leq P_{DMAX}$	1.20	1.25	1.30	V
Temperature Stability	ST_T			0.7		%
Minimum Load Current to Maintain Regulation	$I_{L(MIN)}$	$V_I - V_O = 40V$ $V_I - V_O = 5V$ $P_D < P_{DMAX}$ $V_I - V_O = 40V$ $P_D < P_{DMAX}$, $T_A = +25^\circ C$		3.5 100 25	10	mA
RMS Noise, % of V_{OUT}	e_N	$T_A = +25^\circ C$ $10Hz < f < 10KHz$		0.003		%/ V_O
Ripple Rejection	RR	$V_O = 10V$, $f = 120Hz$ without C_{ADJ} $C_{ADJ} = 10\mu F$	66	65 80		dB
Long-Term Stability	ST	$T_J = +125^\circ C$, 1000 Hours		0.3		%

* Load and Line regulation are specified at constant junction temperature. Change in V_O due to heating effects must be taken into account separately. Pulse testing with low duty cycle is used.

LM317L (KA317) ADJUSTABLE VOLTAGE REGULATOR (POSITIVE)

TYPICAL APPLICATIONS

Fig. 1 5V Electronic Shutdown Regulator

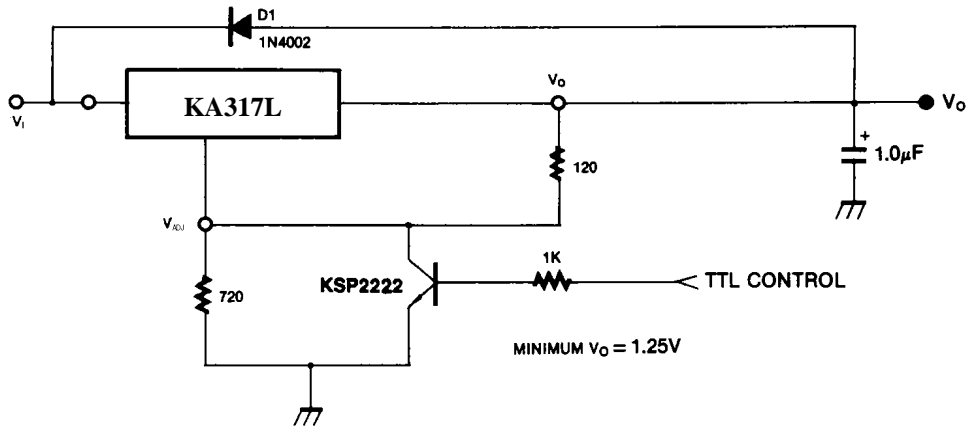

D1 protects the device during an input short circuit.

Fig. 2 Slow Turn-On Regulator

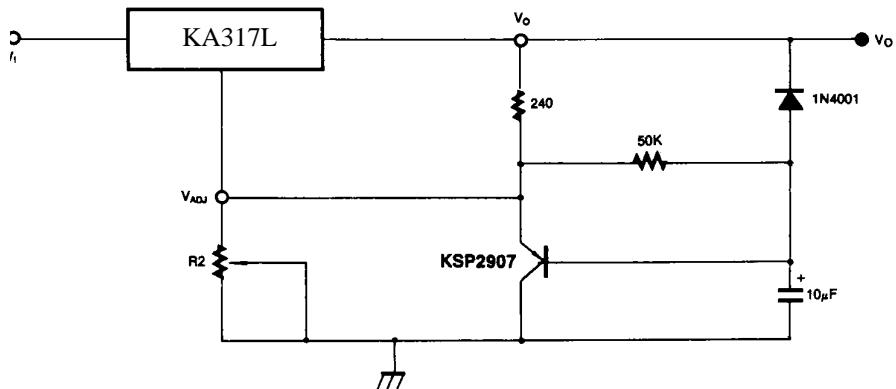

LM317L (KA317) ADJUSTABLE VOLTAGE REGULATOR (POSITIVE)

Fig. 3 Current Regulator

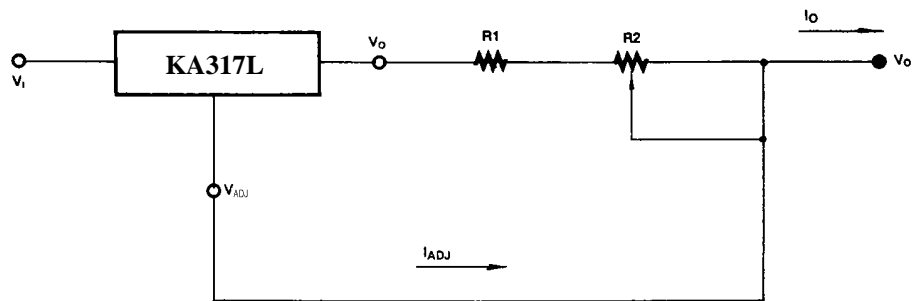

$$I_{OMAX} = \left(\frac{V_{REF}}{R_1} \right) + I_{ADJ} \approx \frac{1.25V}{R_1}$$
$$I_{OMIN} = \left(\frac{V_{REF}}{R_1 + R_2} \right) + I_{ADJ} \approx \frac{1.25V}{R_1 + R_2}$$
$$5mA < I_o < 500mA$$

FAIRCHILD
SEMICONDUCTOR™

PACKAGE DIMENSION

TO-92

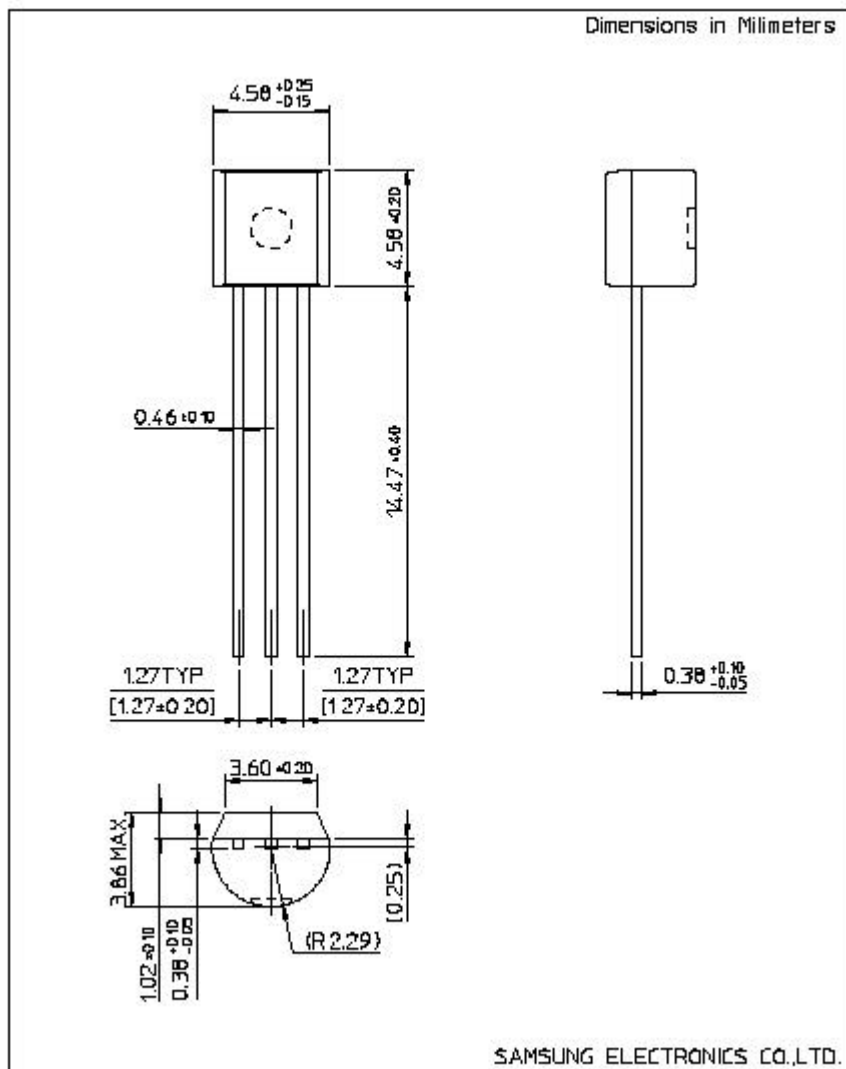

TRADEMARKS

The following are registered and unregistered trademarks Fairchild Semiconductor owns or is authorized to use and is not intended to be an exhaustive list of all such trademarks.

ACEx™	ISOPLANAR™
CoolFET™	MICROWIRE™
CROSSVOLT™	POP™
E ² CMOS™	PowerTrench™
FACT™	QS™
FACT Quiet Series™	Quiet Series™
FAST®	SuperSOT™-3
FASTr™	SuperSOT™-6
GTO™	SuperSOT™-8
HiSeC™	TinyLogic™

DISCLAIMER

FAIRCHILD SEMICONDUCTOR RESERVES THE RIGHT TO MAKE CHANGES WITHOUT FURTHER NOTICE TO ANY PRODUCTS HEREIN TO IMPROVE RELIABILITY, FUNCTION OR DESIGN. FAIRCHILD DOES NOT ASSUME ANY LIABILITY ARISING OUT OF THE APPLICATION OR USE OF ANY PRODUCT OR CIRCUIT DESCRIBED HEREIN; NEITHER DOES IT CONVEY ANY LICENSE UNDER ITS PATENT RIGHTS, NOR THE RIGHTS OF OTHERS.

LIFE SUPPORT POLICY

FAIRCHILD'S PRODUCTS ARE NOT AUTHORIZED FOR USE AS CRITICAL COMPONENTS IN LIFE SUPPORT DEVICES OR SYSTEMS WITHOUT THE EXPRESS WRITTEN APPROVAL OF FAIRCHILD SEMICONDUCTOR CORPORATION. As used herein:

1. Life support devices or systems are devices or systems which, (a) are intended for surgical implant into the body, or (b) support or sustain life, or (c) whose failure to perform when properly used in accordance with instructions for use provided in the labeling, can be reasonably expected to result in significant injury to the user.
2. A critical component is any component of a life support device or system whose failure to perform can be reasonably expected to cause the failure of the life support device or system, or to affect its safety or effectiveness.

PRODUCT STATUS DEFINITIONS

Definition of Terms

Datasheet Identification	Product Status	Definition
Advance Information	Formative or In Design	This datasheet contains the design specifications for product development. Specifications may change in any manner without notice.
Preliminary	First Production	This datasheet contains preliminary data, and supplementary data will be published at a later date. Fairchild Semiconductor reserves the right to make changes at any time without notice in order to improve design.
No Identification Needed	Full Production	This datasheet contains final specifications. Fairchild Semiconductor reserves the right to make changes at any time without notice in order to improve design.
Obsolete	Not In Production	This datasheet contains specifications on a product that has been discontinued by Fairchild semiconductor. The datasheet is printed for reference information only.