

3-TERMINAL 3A POSITIVE ADJUSTABLE VOLTAGE REGULATORS

The KA350 is an adjustable 3-terminal positive voltage regulator capable of supplying in excess of 3.0 A over an output voltage range of 1.2V to 33 V

FEATURES

- Output adjustable between 1.2V and 33V
- Guaranteed 3A output current
- Internal thermal overload protection
- Load regulation (Typ: 0.1%)
- Line regulation (Typ: 0.005%V)
- Internal short-circuit current limiting
- Output transistor safe-area compensation

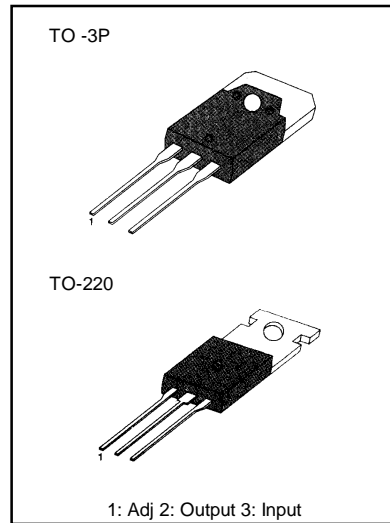

ORDERING INFORMATION

Device	Package	Operating Temperature
KA350H	TO - 3P	0 ~ 125°C
KA350	TO - 220	

BLOCK DIAGRAM

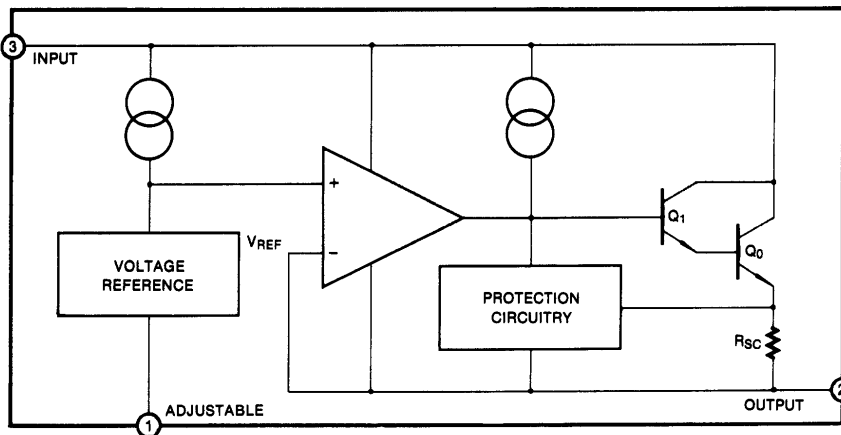

ABSOLUTE MAXIMUM RATINGS ($T_A = 25^\circ\text{C}$, unless otherwise specified)

Characteristic	Symbol	Value	Unit
Input-Output Voltage Differential	$V_I - V_O$	35	V_{DC}
Lead Temperature (Soldering, 10sec)	T_{LEAD}	300	$^\circ\text{C}$
Power Dissipation	P_D	Internally limited	
Operating Temperature Range	T_{OPR}	0 ~ + 125	$^\circ\text{C}$
Storage Temperature Range	T_{STG}	-65 ~ + 150	$^\circ\text{C}$

ELECTRICAL CHARACTERISTICS

($V_I - V_O = 5V$, $I_O = 1.5A$, $T_J = 0^\circ\text{C}$ to 125°C ; P_{MAX} , unless otherwise specified)

Characteristic	Symbol	Test Conditions	Min	Typ	Max	Unit
Line Regulation	ΔV_O	$T_A = 25^\circ\text{C}$, $3V \leq V_I - V_O \leq 35V$ (Note 1)		0.05	0.03	$\%/V$
Load Regulation	ΔV_O	$T_A = 25^\circ\text{C}$, $3V \leq V_I - V_O \leq 35V$ $V_O \leq 5V$ (Note 1) $V_O = 5V$ (Note 1)		5 0.1	25 0.5	mV %
Adjustment Pin Current	I_{ADJ}			50	100	μA
Adjustment Pin Current Change	ΔI_{ADJ}	$3V \leq V_I - V_O \leq 35V$, $10\text{mA} \leq I_L \leq 3A$, $P_D \leq P_{MAX}$		0.2	5.0	μA
Thermal Regulation	REG_T	Pulse = 20ms, $T_A = 25^\circ\text{C}$		0.002		$\%/W$
Reference Voltage	V_{REF}	$3V \leq V_I - V_O \leq 35V$, $10\text{mA} \leq I_O \leq 3A$, $P \leq 30W$	1.2	1.25	1.30	V
Line Regulation	ΔV_O	$3.0V \leq V_I - V_O \leq 35V$		0.02	0.07	$\%/W$
Load Regulation	ΔV_O	$10\text{mA} \leq I_O \leq 3.0A$ $V_O \leq 5.0V$ $V_O = 5.0V$		20 0.3	70 1.5	mV %
Temperature Stability	ST_T	$T_J = 0^\circ\text{C}$ to 125°C		1.0		%
Maximum Output Current	$I_{O(MAX)}$	$V_I - V_O \leq 10V$, $P_D \leq P_{MAX}$ $V_I - V_O = 30V$, $P_D \leq P_{MAX}$, $T_A = 25^\circ\text{C}$	3.0 0.25	4.5 1.0		A A
Minimum Load Current	$I_{L(MIN)}$	$V_I - V_O = 35V$		3.5	10	mA
RMS Noise, % of V_{OUT}	V_N	$10\text{Hz} \leq f \leq 10\text{KHz}$, $T_A = 25^\circ\text{C}$		0.003		%
Ripple Rejection	RR	$V_O = 10V$, $f = 120\text{Hz}$, $C_{ADJ} = 0$ $C_{ADJ} = 10 \mu\text{F}$	66	65 80		dB dB
Long-Term Stability	ST	$T_J = 125^\circ\text{C}$		0.3	1	$\%/1000\text{HR}$

Note 1: Regulation is measured at constant junction temperature. Changes in output voltage due to heating effects must be taken into account separately. Pulse testing with low duty cycle is used.

TYPICAL PERFORMANCE CHARACTERISTICS

Fig. 1 LOAD REGULATION

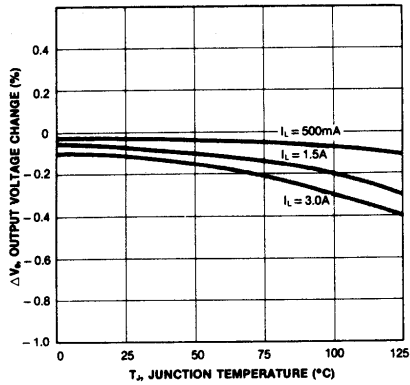

Fig. 2 CURRENT LIMIT

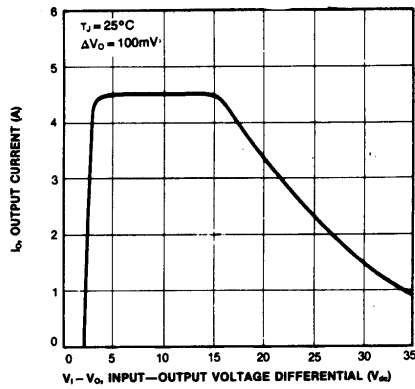

Fig. 3 ADJUSTMENT PIN CURRENT

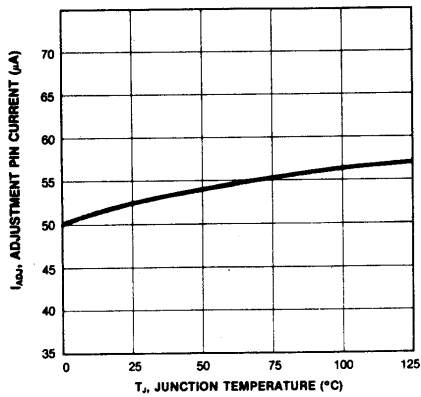

Fig. 4 DROPOUT VOLTAGE

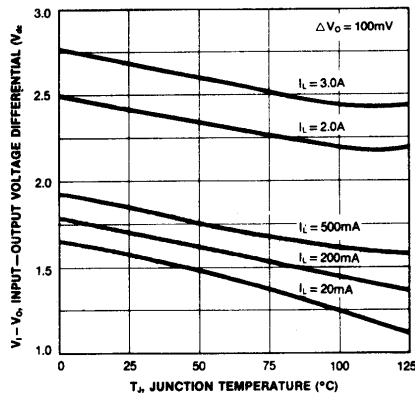

Fig. 5 TEMPERATURE STABILITY

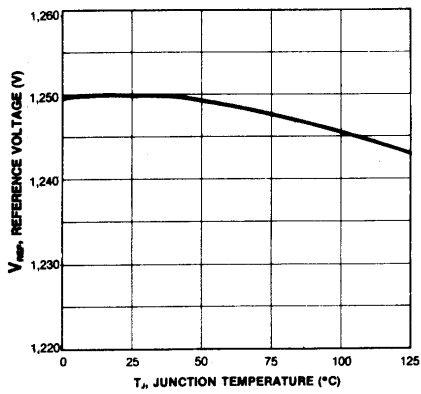
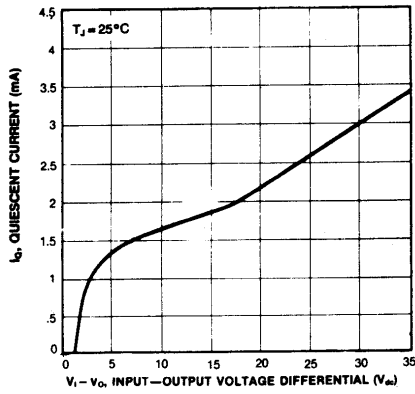

Fig. 6 MINIMUM LOAD CURRENT



TYPICAL PERFORMANCE CHARACTERISTICS

Fig. 7 RIPPLE REJECTION vs V_o

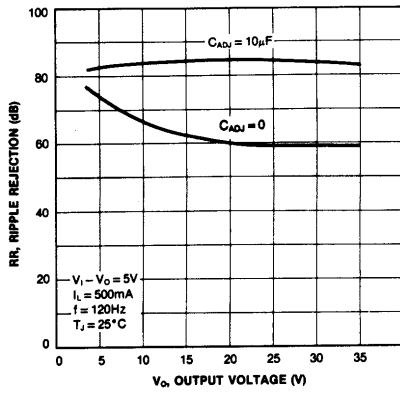

Fig. 8 RIPPLE REJECTION vs I_o

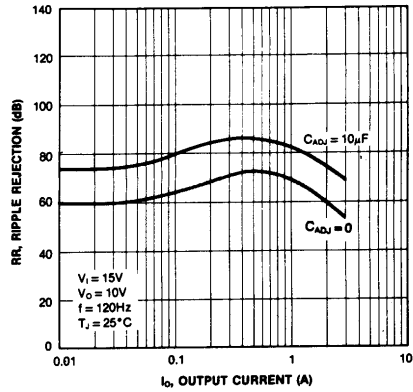

Fig. 9 RIPPLE REJECTION vs FREQUENCY

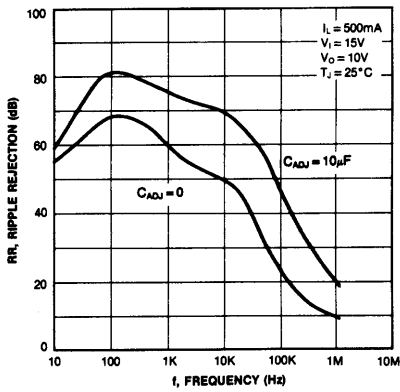

Fig. 10 OUTPUT IMPEDANCE

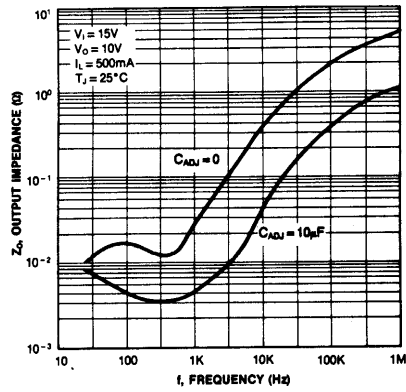

Fig. 11 LINE TRANSIENT RESPONSE

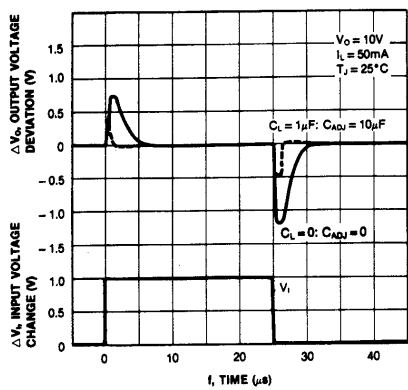
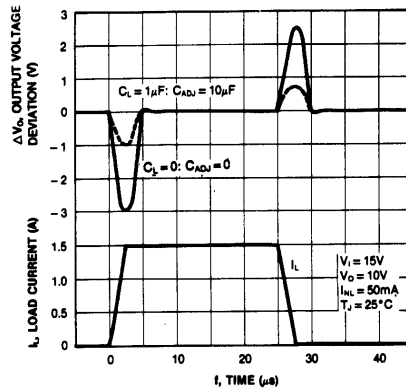

Fig. 12 LOAD TRANSIENT RESPONSE



APPLICATION INFORMATION

STANDARD APPLICATION

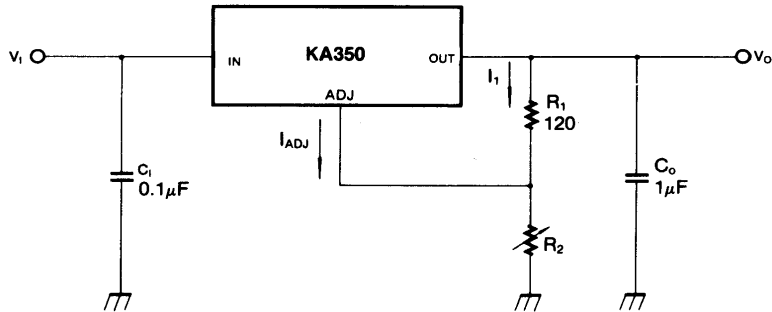

Fig. 13

C_1 : C_1 is required if the regulator is located an appreciable distance from power supply filter.

C_o : Output capacitors in the range of $1\mu\text{F}$ to $100\mu\text{F}$ of aluminum or tantalum electronic are commonly used to provide improved output impedance and rejection of transients.

In operation, the KA350 develops a nominal 1.25V reference voltage, V_{REF} , between the output and adjustment terminal. The reference voltage is impressed across program resistor R_1 and, since the voltage is constant, a constant current I_1 then flows through the output set resistor R_2 , giving an output voltage of

$$V_o = 1.25V \left(1 + \frac{R_2}{R_1}\right) + I_{ADJ} R_2$$

Since I_{ADJ} current (less than $100\mu\text{A}$) from the adjustment terminal represents an error term, the KA350 was designed to minimize I_{ADJ} and make it very constant with line and load changes. To do this, all quiescent operating current is returned to the output establishing a minimum load current requirement. If there is insufficient load on the output, the output voltage will rise.

Since the KA350 is a floating regulator, it is only the voltage differential across the circuit which is important to performance, and operation at high voltage with respect to ground is possible.

TRADEMARKS

The following are registered and unregistered trademarks Fairchild Semiconductor owns or is authorized to use and is not intended to be an exhaustive list of all such trademarks.

ACEx™	ISOPLANAR™	UHC™
CoolFET™	MICROWIRE™	VCX™
CROSSVOLT™	POP™	
E ² CMOS™	PowerTrench™	
FACT™	QST™	
FACT Quiet Series™	Quiet Series™	
FAST®	SuperSOT™-3	
FASTr™	SuperSOT™-6	
GTO™	SuperSOT™-8	
HiSeC™	TinyLogic™	

DISCLAIMER

FAIRCHILD SEMICONDUCTOR RESERVES THE RIGHT TO MAKE CHANGES WITHOUT FURTHER NOTICE TO ANY PRODUCTS HEREIN TO IMPROVE RELIABILITY, FUNCTION OR DESIGN. FAIRCHILD DOES NOT ASSUME ANY LIABILITY ARISING OUT OF THE APPLICATION OR USE OF ANY PRODUCT OR CIRCUIT DESCRIBED HEREIN; NEITHER DOES IT CONVEY ANY LICENSE UNDER ITS PATENT RIGHTS, NOR THE RIGHTS OF OTHERS.

LIFE SUPPORT POLICY

FAIRCHILD'S PRODUCTS ARE NOT AUTHORIZED FOR USE AS CRITICAL COMPONENTS IN LIFE SUPPORT DEVICES OR SYSTEMS WITHOUT THE EXPRESS WRITTEN APPROVAL OF FAIRCHILD SEMICONDUCTOR CORPORATION. As used herein:

1. Life support devices or systems are devices or systems which, (a) are intended for surgical implant into the body, or (b) support or sustain life, or (c) whose failure to perform when properly used in accordance with instructions for use provided in the labeling, can be reasonably expected to result in significant injury to the user.
2. A critical component is any component of a life support device or system whose failure to perform can be reasonably expected to cause the failure of the life support device or system, or to affect its safety or effectiveness.

PRODUCT STATUS DEFINITIONS

Definition of Terms

Datasheet Identification	Product Status	Definition
Advance Information	Formative or In Design	This datasheet contains the design specifications for product development. Specifications may change in any manner without notice.
Preliminary	First Production	This datasheet contains preliminary data, and supplementary data will be published at a later date. Fairchild Semiconductor reserves the right to make changes at any time without notice in order to improve design.
No Identification Needed	Full Production	This datasheet contains final specifications. Fairchild Semiconductor reserves the right to make changes at any time without notice in order to improve design.
Obsolete	Not In Production	This datasheet contains specifications on a product that has been discontinued by Fairchild semiconductor. The datasheet is printed for reference information only.