

VOLTAGE - MODE PWM CONTROLLER

The KA3526B is an excellent PWM controller for SMPS and other power control applications. Functions included in an 18 dual-in-line package are a temperature stable voltage reference, pulse width modulator, error amplifier, sawtooth oscillator and two low impedance power drivers. Protective features are included such as under voltage lockout, soft start, digital current limiting, adjustable deadtime and double pulse inhibit.

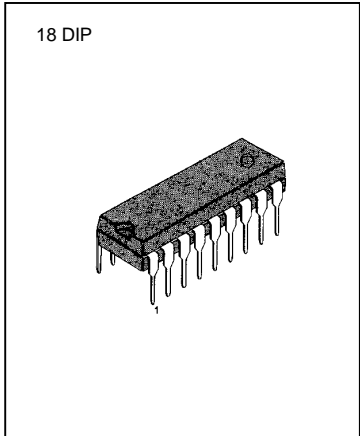

FEATURES

- 8 to 35V Operation
- 5V Bandgap Reference Trimmed to $\pm 1\%$
- Dual 100mA Source/Sink Outputs
- Programmable Dead Time
- Under-Voltage Lockout
- Single Pulse Metering
- Programmable Soft-Start
- Wide Current Limit Common Mode Range
- TTL/CMOS Compatible Logic Parts
- Symmetry Correction Capability
- Digital Current Limiting

ORDERING INFORMATION

Device	Package	Operating Temperature
KA3526B	18 DIP	0 ~ +70 °C

BLOCK DIAGRAM

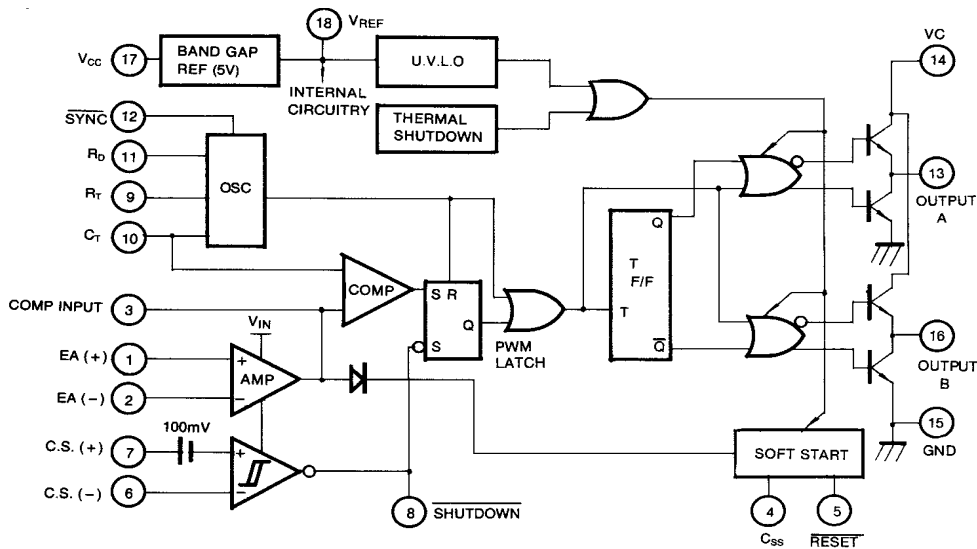

ABSOLUTE MAXIMUM RATINGS

Characteristic	Symbol	Value	Unit
Supply voltage	V_{CC}	40	V
Collector Supply Voltage	V_C	40	V
Output Current, Sink or Source	I_o	200	mA
Reference Output Current	I_{REF}	50	mA
Power Dissipation ($T_A = 25^\circ\text{C}$)	P_D	1000	mW
Operating Temperature	T_{OPR}	0 ~ +70	$^\circ\text{C}$
Storage Temperature	T_{STG}	- 65 ~ +150	$^\circ\text{C}$
Lead Temperature (Soldering, 10sec)	T_{LEAD}	+300	$^\circ\text{C}$

ELECTRICAL CHARACTERISTICS

($V_{CC} = 15\text{V}$, $T_A = 0^\circ\text{C}$ to $+70^\circ\text{C}$, unless otherwise specified)

Characteristic	Symbol	Test Conditions	Min	Typ	Max	Unit
REFERENCE SECTION						
Reference Output Voltage	V_{REF}	$T_J = 25^\circ\text{C}$	4.9	5.0	5.1	V
Line Regulation	ΔV_{REF}	$V_{CC} = 7$ to 35V		2.0	15	mV
Load Regulation	ΔV_{REF}	$I_{REF} = 0$ to 20mA		5.0	20	mV
Temperature Stability (Note)	ST_T	$T_J = 0$ to $+70^\circ\text{C}$		15	50	mV
Output Voltage Range (Note)	ΔV_{REF}		4.85	5.0	5.15	V
Short-Circuit Output Current	I_{SC}	$V_{REF} = 0\text{V}$	25	50	100	mA
UNDER-VOLTAGE LOCKOUT SECTION						
RESET Output Voltage	$V_{O(RESET)}$	$V_{REF} = 3.8\text{V}$		0.2	0.4	V
RESET Output Voltage	$V_{O(RESET)}$	$V_{REF} = 4.7\text{V}$	2.4	4.8		V
OSCILLATOR SECTION ($f = 40\text{KHz}$; $R_T = 4.12\text{K}\Omega \pm 1\%$, $C_T = 0.01\mu\text{F} \pm 1\%$, $R_D = 0\Omega$)						
Initial Accuracy	ACCUR	$T_J = 25^\circ\text{C}$		± 3	± 8	%
Frequency Change with Voltage	$\Delta f/\Delta V_{CC}$	$V_{CC} = 7$ to 35V		0.5	1.0	%
Frequency Change with Temperature(Note)	$\Delta f/\Delta T$	$T_J = 0$ to 70°C		1.0	3.0	%
Minimum Frequency	$f_{(MIN)}$	$R_T = 150\text{K}\Omega$, $C_T = 20\mu\text{F}$			1.0	Hz
Maximum Frequency	$f_{(MAX)}$	$R_T = 2\text{K}\Omega$, $C_T = 470\text{pF}$	550	650		KHz
Sawtooth Peak Volotage	$V_{PK(SAW)}$	$V_{CC} = 35\text{V}$		3.0	3.5	V
Sawtooth Valley Voltage	$V_{VL(SAW)}$	$V_{IN} = 7\text{V}$	0.5	1.0		V
SYNC Pulse Width	$t_{W(SYNC)}$	$R_L = 2.7\Omega$ to V_{REF} , $T_J = 25^\circ\text{C}$		1.1		μS

ELECTRICAL CHARACTERISTICS ($V_{CC} = 15V$, $T_A = 0^\circ C$ to $+70^\circ C$, unless otherwise specified)

Characteristic	Symbol	Test Conditions	Min	Typ	Max	Unit
ERROR AMPLIFIER SECTION ($V_{CM} = 0$ to $5.2V$)						
Input Offset Voltage	V_{IO}	$R_S \leq 2K\Omega$		0.8	10	mV
Input Bias Current	I_{BIAS}			- 90	- 2000	nA
Input Offset Current	I_{IO}			5	200	nA
Open Loop Voltage Gain	G_{VO}	$R_1 \geq 10M\Omega$, $T_J = 25^\circ C$	60	72		dB
High Output Voltage	V_{OH}	$V_1 - V_2 \geq 0.15V$ $I_{SOURCE} = 100\mu A$	3.6	4.2		V
Low Output Voltage	V_{OL}	$V_2 - V_1 \geq 0.15V$ $I_{SOURCE} = 100\mu A$		0.2	0.4	V
Common Mode Rejection Ratio	CMRR	$R_2 \leq 2K\Omega$	70	94		dB
Power Supply Rejection Ratio	PSRR	$V_{CC} = 12$ to $18V$	66	80		dB
PWM COMPARATOR SECTION ($f = 40KHz$; $R_T = 4.12K\Omega \pm 1\%$, $C_T = 0.01\mu F \pm 1\%$, $R_D = 0\Omega$)						
Minimum Duty Cycle	$D_{(MIN)}$	$V_3 = 0.4V$			0	%
Maximum Duty Cycle	$D_{(MAX)}$	$V_3 = 3.6V$	45	49		%
DIGITAL PORTS (SYNC, SHUTDOWN and RESET)						
High Output Voltage	V_{OH}	$I_{SOURCE} = 40\mu A$	2.4	4.0		V
Low Output Voltage	V_{OL}	$I_{SINK} = 3.6mA$		0.2	0.4	V
High Input Current	I_{IH}	$V_{IH} = 2.4V$		-125	- 200	μA
Low Input Current	I_{IL}	$V_{IL} = 0.4V$		- 225	- 360	μA
Shutdown Delay	$t_{D(SD)}$	From Pin 8, $T_J = 25^\circ C$		160		ns
CURRENT LIMIT COMPARATOR SECTION ($V_{CM} = 0$ to $12V$)						
Sense Voltage	V_{SENSE}	$R_S \leq 50\Omega$, $T_J = 25^\circ C$	80	100	120	mV
Input Bias Current	I_{BIAS}			- 3.0	- 10	μA
SOFT-START SECTION						
Error Clamp Voltage	V_{EC}	$V_5 = 0.4V$		0.1	0.4	V
C_S Charging Current	$I_{CHG(CS)}$	$V_5 = 2.4V$	50	100	150	μA
OUTPUT DRIVERS (Each Output) ($V_C = 15V$)						
High Output Voltage 1	V_{OH1}	$I_{SOURCE} = 20mA$	12.5	13.5		V
High Output Voltage 2	V_{OH2}	$I_{SOURCE} = 100mA$	12	13		V
Low Output Voltage 1	V_{OL1}	$I_{SINK} = 20mA$		0.2	0.3	V
Low Output Voltage 2	V_{OL2}	$I_{SINK} = 100mA$		1.2	2.0	V
Collector Leakage Current	I_{LKG}	$V_C = 40V$		50	150	μA
Rise Time	t_R	$C_L = 1nF$		0.3	0.6	μS
Fall Time	t_F	$C_L = 1nF$		0.1	0.2	μS
Cross Conduction Charge	C_C	Per Cycle, $T_J = 25^\circ C$		8		nC
POWER CONSUMPTION SECTION ($V_{CC} = 35V$, $R_T = 4.12K\Omega$)						
Supply Current	I_{CC}	$V_8 = 0.4V$		14	25	mA

NOTE

- These parameters although guaranteed over the recommended operating conditions are not 100% tested in production.

TRADEMARKS

The following are registered and unregistered trademarks Fairchild Semiconductor owns or is authorized to use and is not intended to be an exhaustive list of all such trademarks.

ACEx™	ISOPLANAR™	UHC™
CoolFET™	MICROWIRE™	VCX™
CROSSVOLT™	POP™	
E ² CMOS™	PowerTrench™	
FACT™	QST™	
FACT Quiet Series™	Quiet Series™	
FAST®	SuperSOT™-3	
FASTr™	SuperSOT™-6	
GTO™	SuperSOT™-8	
HiSeC™	TinyLogic™	

DISCLAIMER

FAIRCHILD SEMICONDUCTOR RESERVES THE RIGHT TO MAKE CHANGES WITHOUT FURTHER NOTICE TO ANY PRODUCTS HEREIN TO IMPROVE RELIABILITY, FUNCTION OR DESIGN. FAIRCHILD DOES NOT ASSUME ANY LIABILITY ARISING OUT OF THE APPLICATION OR USE OF ANY PRODUCT OR CIRCUIT DESCRIBED HEREIN; NEITHER DOES IT CONVEY ANY LICENSE UNDER ITS PATENT RIGHTS, NOR THE RIGHTS OF OTHERS.

LIFE SUPPORT POLICY

FAIRCHILD'S PRODUCTS ARE NOT AUTHORIZED FOR USE AS CRITICAL COMPONENTS IN LIFE SUPPORT DEVICES OR SYSTEMS WITHOUT THE EXPRESS WRITTEN APPROVAL OF FAIRCHILD SEMICONDUCTOR CORPORATION. As used herein:

1. Life support devices or systems are devices or systems which, (a) are intended for surgical implant into the body, or (b) support or sustain life, or (c) whose failure to perform when properly used in accordance with instructions for use provided in the labeling, can be reasonably expected to result in significant injury to the user.
2. A critical component is any component of a life support device or system whose failure to perform can be reasonably expected to cause the failure of the life support device or system, or to affect its safety or effectiveness.

PRODUCT STATUS DEFINITIONS

Definition of Terms

Datasheet Identification	Product Status	Definition
Advance Information	Formative or In Design	This datasheet contains the design specifications for product development. Specifications may change in any manner without notice.
Preliminary	First Production	This datasheet contains preliminary data, and supplementary data will be published at a later date. Fairchild Semiconductor reserves the right to make changes at any time without notice in order to improve design.
No Identification Needed	Full Production	This datasheet contains final specifications. Fairchild Semiconductor reserves the right to make changes at any time without notice in order to improve design.
Obsolete	Not In Production	This datasheet contains specifications on a product that has been discontinued by Fairchild semiconductor. The datasheet is printed for reference information only.