

## POWER WINDOW MOTOR CONTROL IC

The KA3903 is a monolithic integrated circuit, and suitable for a window motor control and sun a roof motor control in automotive systems.

### FEATURES

- Protections
  - Human body protection with a simple switch
  - Over current protection with an integrator
  - Over voltage protection
  - Load dump protection
  - Reverse battery voltage protection
- Low off-state quiescent current (150 $\mu$ A)
- Adjustable output control time after car-key turn-off
- Four selectable operating modes
- Thermal shutdown (TSD)
- Under voltage lockout

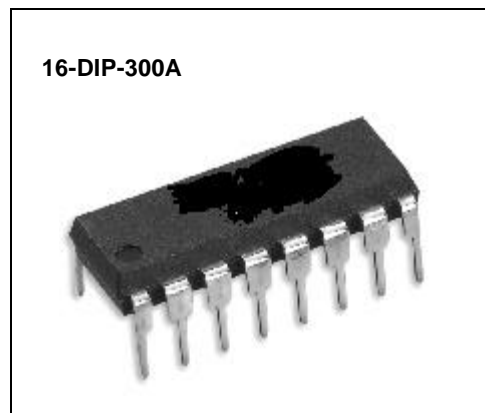

### ORDERING INFORMATION

Device	Package	Operating Temperature
KA3903	16-DIP-300A	-40°C ~ +90°C

BLOCK DIAGRAM

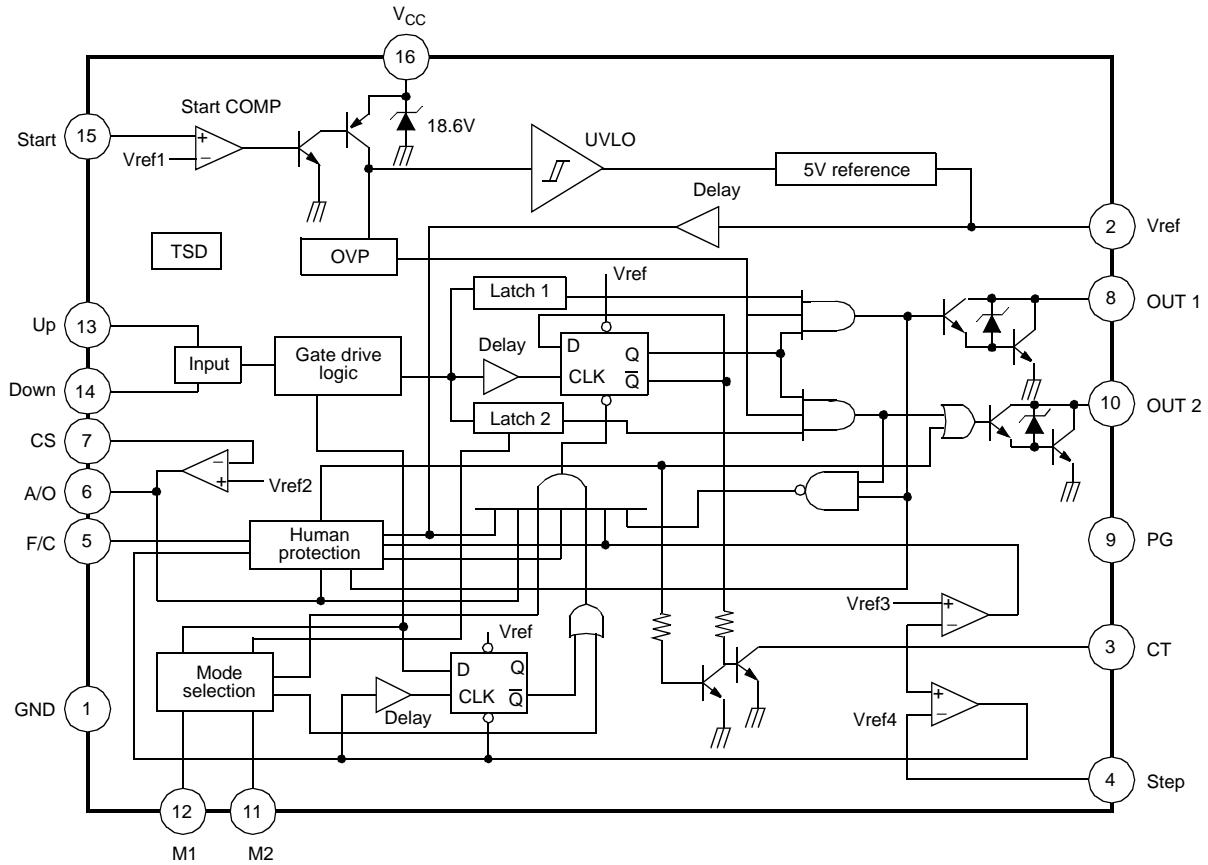

## PIN CONFIGURATION

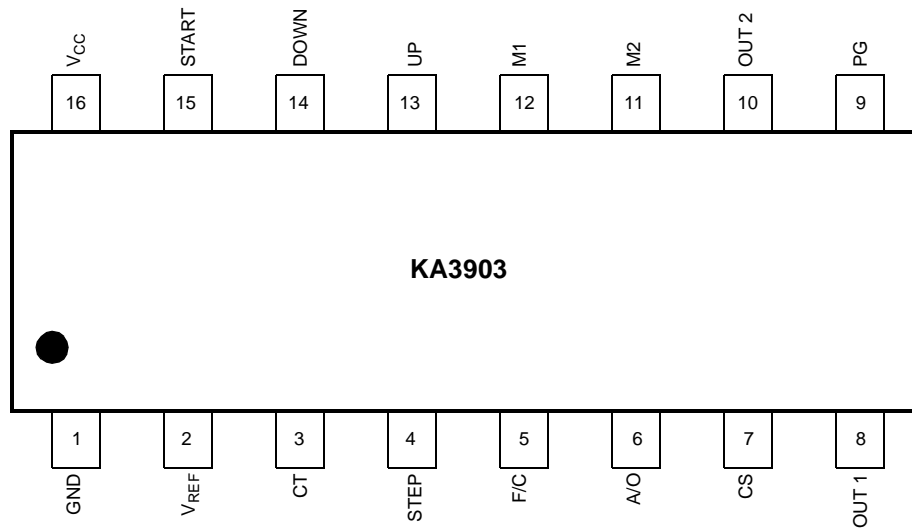

## PIN DESCRIPTION

Pin No.	Symbol	Description
1	GND	Signal ground
2	Vref	Voltage reference output (typ=5.0V)
3	CT	Step / Auto pulse generator output
4	STEP	Step bias signal input
5	F/C	Full close signal input
6	A/O	OP amp output
7	CS	Current sense signal input
8	OUT 1	Up signal output
9	PG	Power ground
10	OUT 2	Down signal output
11	M2	Selectable mode signal input 2
12	M1	Selectable mode signal input 1
13	UP	Up signal input
14	DOWN	Down signal input
15	START	Start up signal input
16	V <sub>CC</sub>	Supply voltage

**ABSOLUTE MAXIMUM RATING (Ta=25°C, unless otherwise specified)**

Characteristics	Symbol	Value	Unit
Supply voltage 1	V <sub>CC1</sub>	17	V
Supply voltage 2: reverse bias	V <sub>CC2</sub>	-0.7	V
Output current	I <sub>O</sub>	400	mV
Power dissipation	P <sub>D</sub>	1.0	W
Operating ambient temperature	T <sub>OPR</sub>	-40 ~ +90	°C
Storage temperature	T <sub>STG</sub>	-60 ~ +150	°C

**ELECTRICAL CHARACTERISTICS**(V<sub>CC</sub>=12V, Ta=25°C, unless otherwise specified)

Characteristic	Symbol	Test conditions	Min.	Typ.	Max.	Unit
<b>UNDER VOLTAGE LOCK SECTION</b>						
Start-up threshold voltage	V <sub>ST</sub>	–	8.3	8.8	9.3	V
UVLO hysteresis	V <sub>HYS</sub>	–	1.1	1.25	1.6	V
Supply zener voltage	V <sub>Z</sub>	I <sub>CC</sub> =20mA	17.2	18.6	20.0	V
<b>OPERATING RANGE SECTION</b>						
Operating supply voltage	V <sub>CC</sub>	V <sub>REF</sub> =5V	8.0	–	17.0	V
Operating supply current (Off)	I <sub>CC1</sub>	V <sub>START</sub> =Open	–	150	200	μA
Operating supply current (On)	I <sub>CC2</sub>	V <sub>START</sub> =12V	–	5.0	6.0	mA
<b>REFERENCE SECTION</b>						
Reference voltage	V <sub>REF</sub>	–	4.8	5.0	5.2	V
Line regulation	R <sub>EG</sub> , I <sub>I</sub>	8V < V <sub>CC</sub> < 17V	–	1	2	mV / V
Load regulation	R <sub>EG</sub> , I <sub>O</sub>	0mA < I <sub>REF</sub> < 2mA	–	1	4	mV / mA
<b>COMPARTOR SECTION (UP/DOWN/FG BLOCK)</b>						
Input resistance	R <sub>IN</sub>	V <sub>UP</sub> , V <sub>DOWN</sub> , V <sub>FC</sub> =0V	20	28	36	kΩ
Comparing reference voltage 1	V <sub>TH1</sub>	V <sub>out</sub> on / off S/W V <sub>tg</sub>	3.0	3.2	3.4	V
<b>COMPARATOR SECTION (CT BLOCK)</b>						
Comparing reference voltage 2	V <sub>TH2</sub>	4.2V < V <sub>CT</sub> < 4.6V	4.2	4.4	4.6	V

**ELECTRICAL CHARACTERISTICS (Continued)**(V<sub>CC</sub>=12V, T<sub>a</sub>=25°C, unless otherwise specified)

Characteristic	Symbol	Test conditions	Min.	Typ.	Max.	Unit
<b>OUTPUT SECTION</b>						
Output saturation voltage	V <sub>SAT</sub>	I <sub>O</sub> =0.2A	–	1.0	1.2	V
Sustain voltage	V <sub>SUS</sub>	I <sub>O</sub> =20mA	17.2	18.6	20.0	V
<b>OP AMP SECTION</b>						
AMP reference voltage	V <sub>AMP</sub>	V <sub>CS</sub> =V <sub>outa</sub>	0.23	0.25	0.27	V
Output voltage range	V <sub>OUTH</sub>	I <sub>O</sub> =–10μA	4.0	4.2	–	V
	V <sub>OUT1</sub>	I <sub>O</sub> =+10μA	–	0.05	0.1	V

## APPLICATION INFORMATION

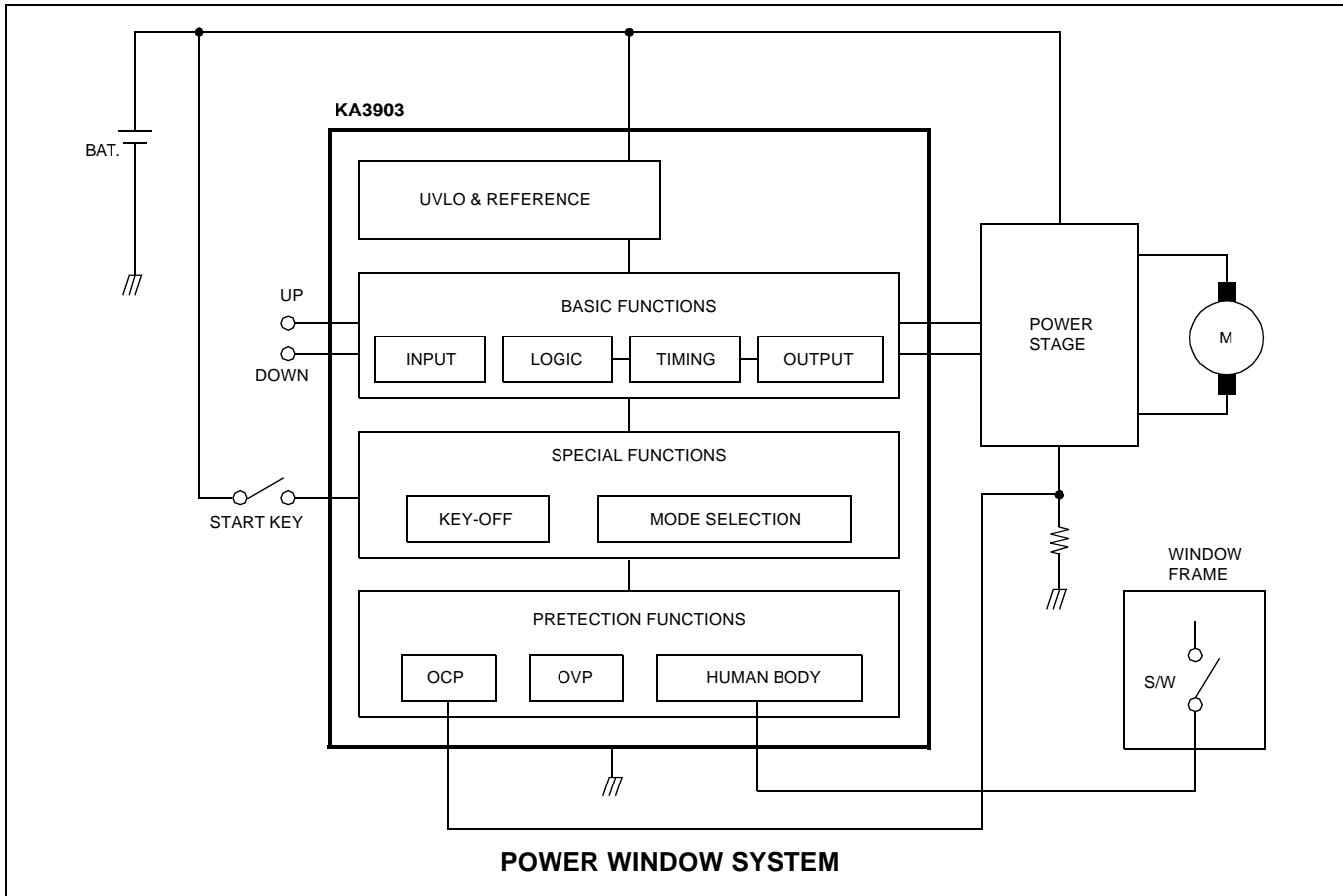

If a battery is mounted on a car, the power window system will be in stand-by as power is supplied into the power stage and the control IC (KA3903).

When the start-key is turned on by operator, the KA3903 will wait the command up or down of the window.

Upon the command up, the power stage composed of relays will be activated by basic function circuit which consists of input, logic, timing and output circuit.

So the motor starts to rotate in the right direction to lift the window, while rotate in the counter direction with the command down to down the window.

The OCP (over current protector) is made up to protect the current overflowed on a motor in an abnormal condition of the system during the rotation of motor according to the command up or down.

The OCP time technique is used to detect over current not sensitive to a start peak current or a current slightly larger than the reference current.

The KA3903 is based on the safety by consisting of the human body protection circuit with a simple switch attached to the window frame for cost-effective method but hard to the european specification. It also is possible to use photo sensor to meet the specification.

Moreover the KA3903 has the car-key turn-off function and the mode selection function.

## 1. START STAGE

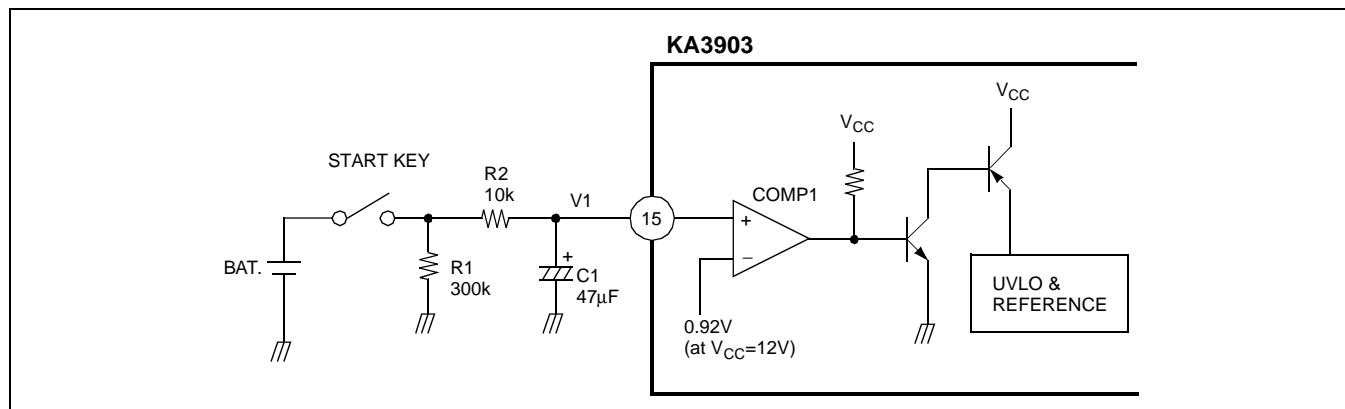

In the state of the start-key turned off, all the blocks in the KA3903 are kept to be off because the power is not supplied into UVLO block.

When the start-key is turned on, the power is supplied into UVLO block to activate reference block in normal condition. So the blocks in KA3903 are kept to be on.

It is minimized the stand-by current of the KA3903, as it performs on or off by using the start stage.

## 2. STEP AND AUTO TIME

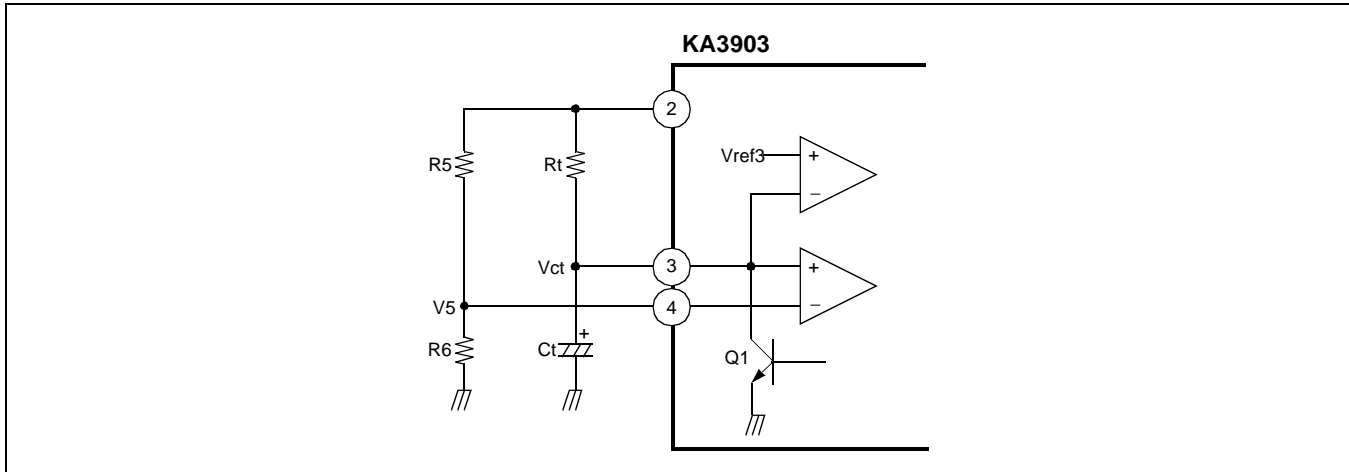

If the up/down switch is pushed less than a set time ( $T_S$ ), TR (Q1) will be turned off and capacitor (Ct) is charged exponentially until Vct equals to V5. At that time TR (Q1) is turned on and stops the operation.

But if longer than  $T_S$ , capacitor (Ct) continues its charge until Vct equals to Vref3. Then Q1 is turned on and the auto function terminates its operation.

The  $T_S$  and  $T_a$  were determinate by components (Rt & Ct), external divider and Vref3.

$$T_S = 0.05 \times (Rt \times Ct), \text{ where } V5 = 0.25V$$

$$T_a = 2.10 \times (Rt \times Ct), \text{ where } Vref3 = 4.4V$$

In the manual mode, the window goes up or down just while a switch is pushed. In the step mode and the auto mode, even after releasing the switch, the window continues its movements except for pushing the switch again (the topple) or happening to the stall condition.

## 3. CAR-KEY TURN-OFF FUNCTION

The window can be operated for a certain period even in the state of the start-key to be off. If the start-key is turned off, the discharge time for the voltage V1 to pin #15 will be determined by the following time constant.

$$\tau = (R1 + R2)C1$$

User can get a time he wants as the discharge time for the voltage V1 by changing the capacity of the cap (C1) and the values of the resistances (R1 or R2).

Therefore, the user can run the window for a limited time (about 30sec) produced from the above expression, even if the start-key is turn off on the window not closed.

4. MODE SELECTION

Mode	Pin Name		Operation	
	M1	M2	UP	DOWN
LL-MODE	L	L	Normal	Normal
LH-MODE	L	H	Normal	Toggle & Auto
HL-MODE	H	L	Normal	Toggle, step & Auto
HH-MODE	H	H	Toggle, step & Auto	Toggle, step & Auto

NOTES:

1. L : M1 or M2 = Ground, H : M1 or M2 = Open
2. NORMAL: The window is working as long as the up or down switch is pressed.
3. TOGGLE: When the window works by pressing the up or down switch, the window is stopped if the up or down switch is pressed once more.
4. STEP & AUTO: If the up or down switch is pressed for a certain period (0.3 seconds), the window works for 0.3 seconds, while 6 seconds if pressed for more than a certain period (0.3 seconds).

5. OVP (Over voltage protection)

It is designed stop the control of the KA3903 if battery voltage is sensed as about 18.6V or more.

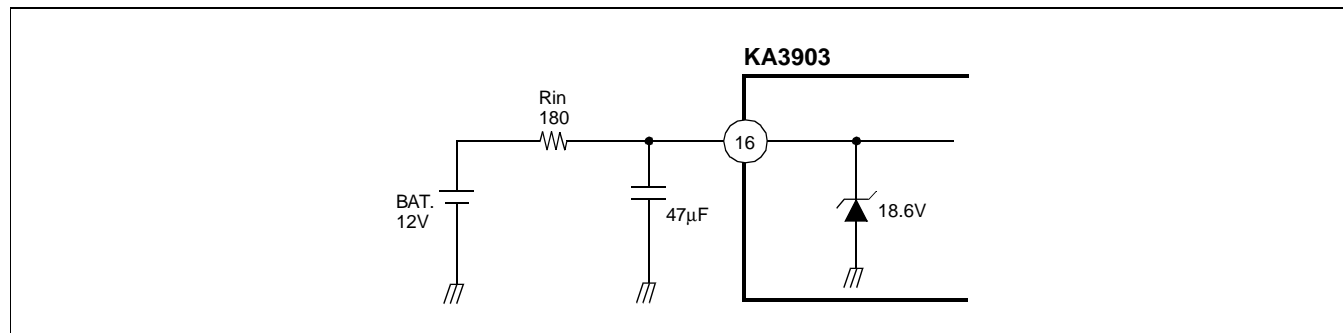

**6. OCP (Over current protection)**

**6-1. Simple applications**

The voltage ( $V_{rs}$ ) proportional to the motor current is generated across the resistor ( $R_S$ ). If the  $V_{rs}$  exceeds the reference voltage ( $V_{ref}$ ), over current part-time integration carried out through  $R_3$ ,  $C_2$  and OP-amp.

When the amount of over current integration is larger than  $S_2$ , the over current signal issued.

The cancel time ( $T_C$ ) between motor stall and motor switch-off is determined by following equations;

$$T_C = (C_2 \times dV) / I_C \quad \text{where, } I_C = (V_{rs} - V_{ref}) / R_3$$

$$dV = V_{outh} - 0.8$$

You can adjust both the value of the sensing resistor ( $R_S$ ) according to motor type and the cancel time by changing  $R_3$  and  $C_2$ . Additionally the over current detection of the KA3903 is immune to any sudden peak current or a current slightly larger than the reference current.

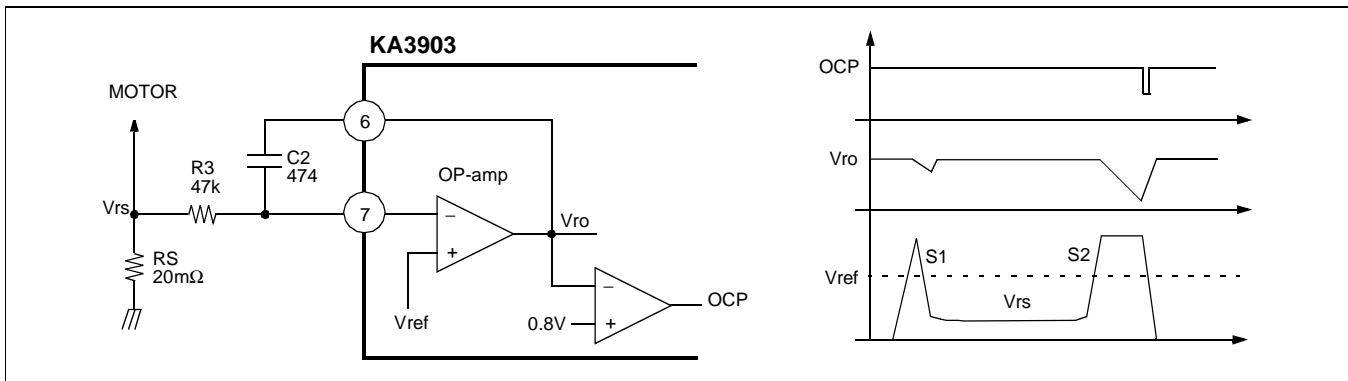

**6-2. Temperature compensation applications**

Generally speaking, the less ambient temperature, the more motor current. In the previous applications, there are some difficulty to decide the reference current level.

In case of low ambient temperature, the difference between the operating motor current and the reference current is very small. When the reference current level is high, the margin is large. But at a high ambient temperature, the difference between the motor current and the stall current is small.

Moreover, the stall current is depended on a battery voltage as well. It is hard to decide what the optimal reference level is.

In the following figure, In the room temperature, the inverting voltage ( $V_2$ ) and the reference current are calculated as follows;

$$V_2 = V_{com} \times R_3 / (R_{ntc} + R_t + R_3)$$

$$V_{com} = V_{ref} - V_2$$

The resistance of the NTC decreases according to rising of the ambient temperature. So the reference level,  $V_{com}$  is changed on the temperature change as shown in the following figure.

To ensure precision of the reference level,  $R_t$  can be adjusted.

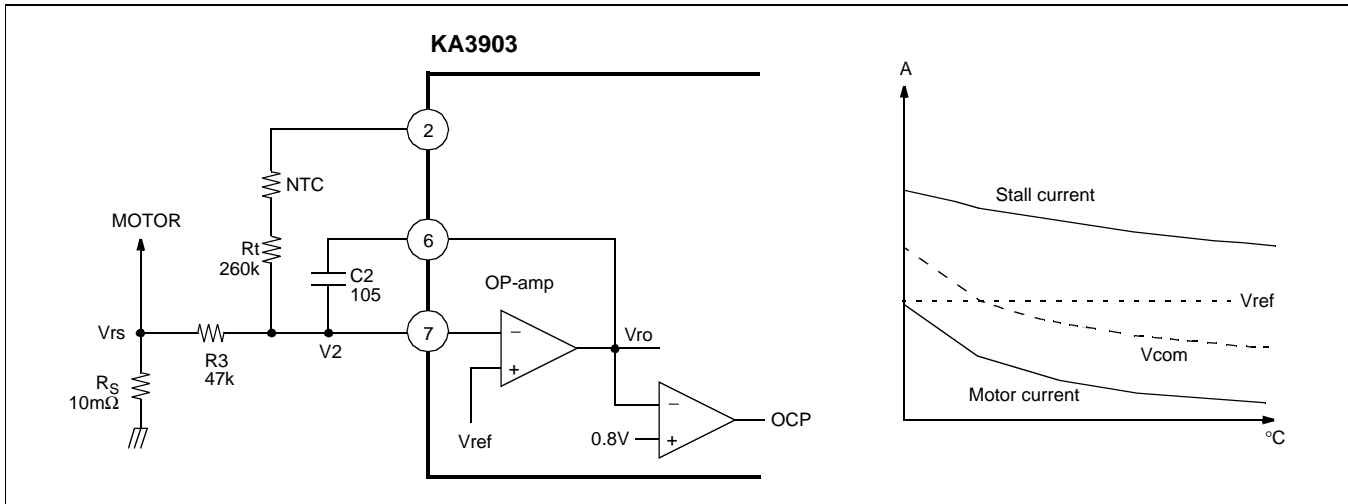

## 7. HUMAN BODY PROTECTION (HBP)

### 7-1. Using an end switch

The human body protection is to be carried out when the over current protection signal is issued just while the window glass is up going and the end switch is closed, in the auto mode. The controller stop the window glass, and then reverses the rotating direction of motor to move down the window plan at the bottom.

There are some cases in the window glass to be locked; its upper limit, bottom, and obstacle like human body, neck, and hand etc. The OCP function would work in any cases. So it is necessary for the controller to discriminate whether something is squeezed between the window glass and the window frame or not.

The end switch is opened only when the window glass reaches almost its upper limit.

Leave the F/C pin open unless you want this function.

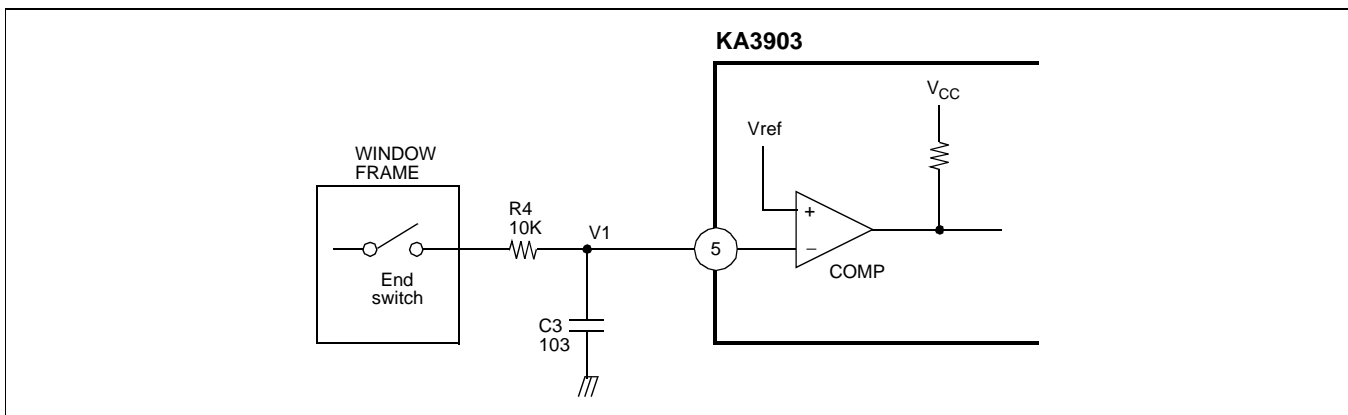

**7-2. Using photo devices (no touch sensor)**

In case of using an end switch, the HBP function works on the condition that the over current signal is issued.

So it could have some sensitivity problem. It is very hard to decide what the optimal reference current and cancel time are.

We have tested new principle and as a result, developed one light based HBP function. The below figure explain the principle of the operation.

As sender and receiver are arranged together, it is possible for the receiver to detect the sent diode light.

The position of the sensor must be set adequately upper part of the window. When the obstacle between the window glass and the upper limit are inserted, the light sensor TR is turned off. The sensor have a two function;

- End position switch,
- Issuing the OCP signal.

Q2 is used to make the F/C pin low, and Q4 enables to turn-on Q6 to issue the OCP signal.

As soon as Q2 is turned on, V2 changes from the equation mentioned in 6.2 paragraph to the below equation.

$$V2 = Vcom \times [R10 // (Rntc + Rt)] / [R10 // (Rntc + Rt) + R5]$$

and OP-amp output become low level. Therefore the HBP logic stops the motor and reverses the direction of the motor.

You can adjust the delay time by changing the value of the resistor, R10. The added part works only when Q5 is on-state. In other words, when the window glass is moving upward, the added part operates. Q3 is also turned on and holds the F/C pin low level.

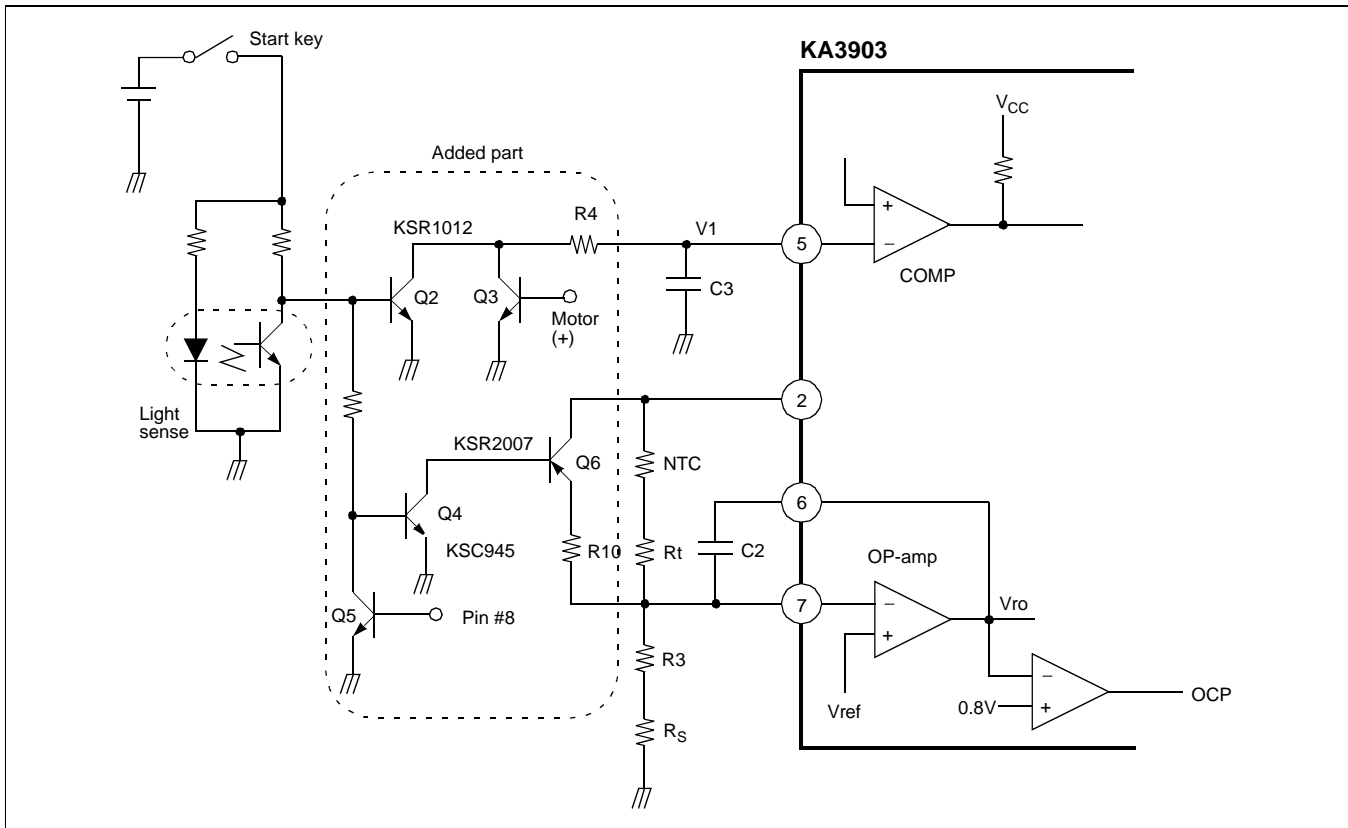

## 8. OUTPUT STAGE

The output stage is a darlington TR with an integrated zener diode, and designed at a pulse current of a approx. 0.4A. The zener diode limits the inductive switch-off voltage. The relay coil has a typical resistances of 200Ω, and the zener diode voltage is 18.6V.

With the circuitry of this type, the KA3903 can sustain 24V for one minute (or continuously) and load dump (70V, 0.2sec) condition without a damage.

## 9. POWER SUPPLY

For the reasons of interference protection and surge immunity, all circuit should be provided with a RC circuit for a current limitation in the event of overvoltage and for buffering in the event of voltage dips at Vref.

Suggested dimensioning; Rin=180Ω, Cin=47μF, as shown in the typical applications.

There is a 18.6V zener diode between V<sub>CC</sub> and GND.

## 10. LOAD DUMP PROTECTION

The load dump protection withstands up to 70V (refer to the typical application-I) with a decay time.

In this case, the power dissipation of the KA3903 takes place at three parts; V<sub>CC</sub>, OUT1 and OUT2.

But in the typical application-II, the supply voltage of the relay is limited the internal zener diode voltage.

The power dissipation of the output stage is not on count. So the KA3903 can withstand up to 100V load dump with τ= 200ms.

## 11. REVERSE BATTERY VOLTAGE PROTECTION

In case of the reverse battery, the KA3903 is modeled with a diode. Due to the external impedance at pin #16, the KA3903 is protected against reverse battery voltage for one minute (or continuously).

APPLICATION CIRCUIT 1

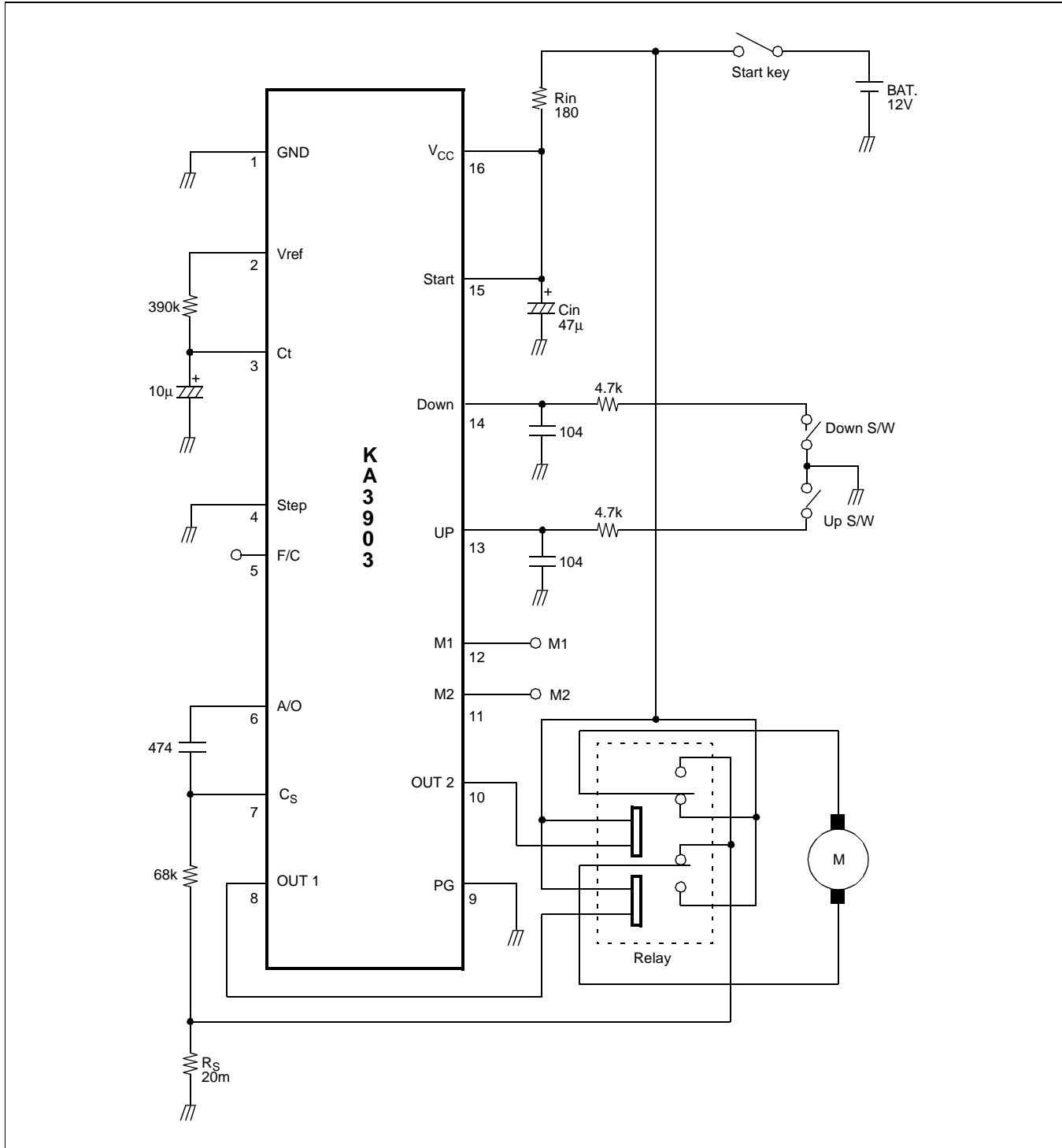

APPLICATION CIRCUIT 2

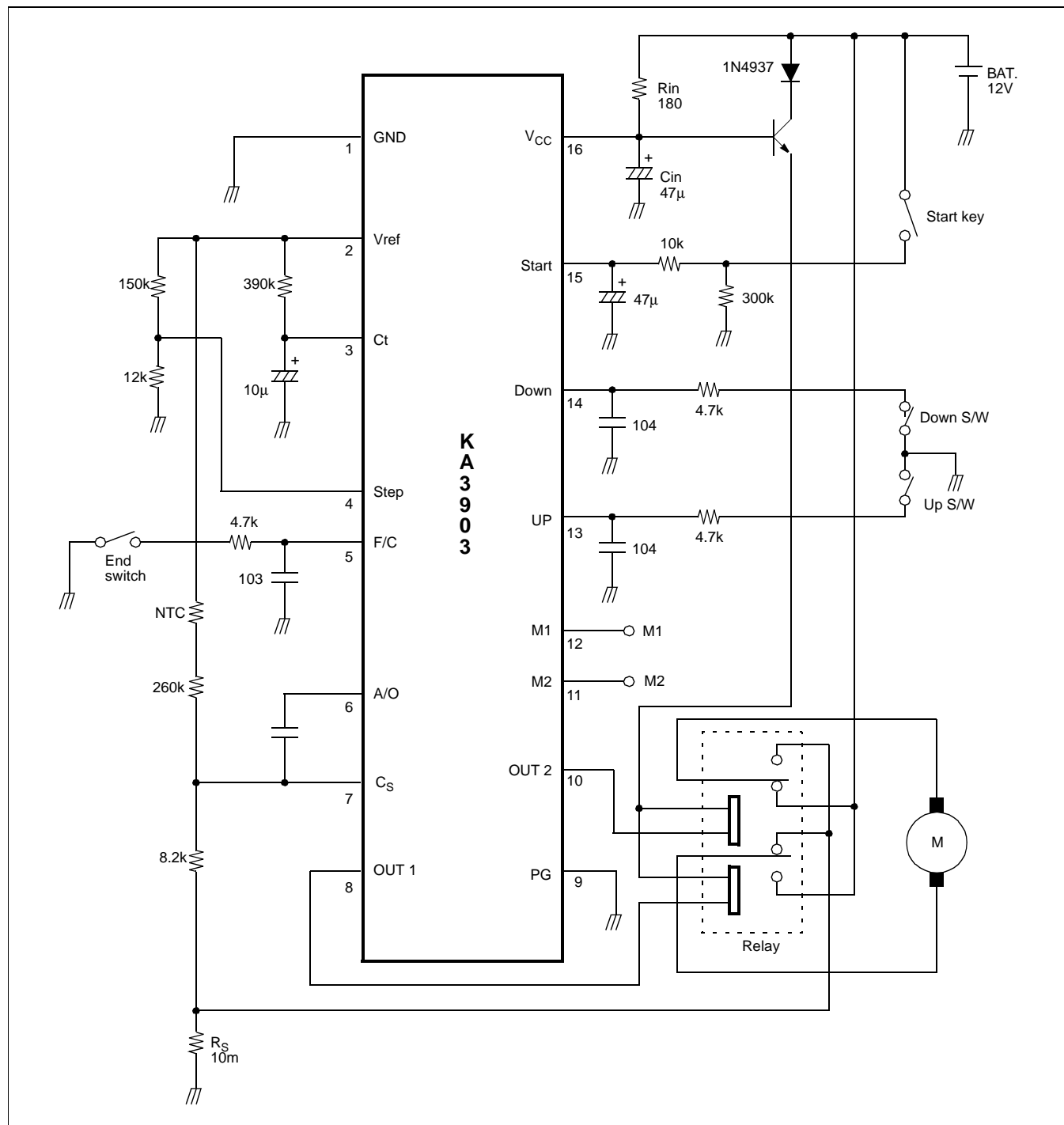

APPLICATION CIRCUIT 3

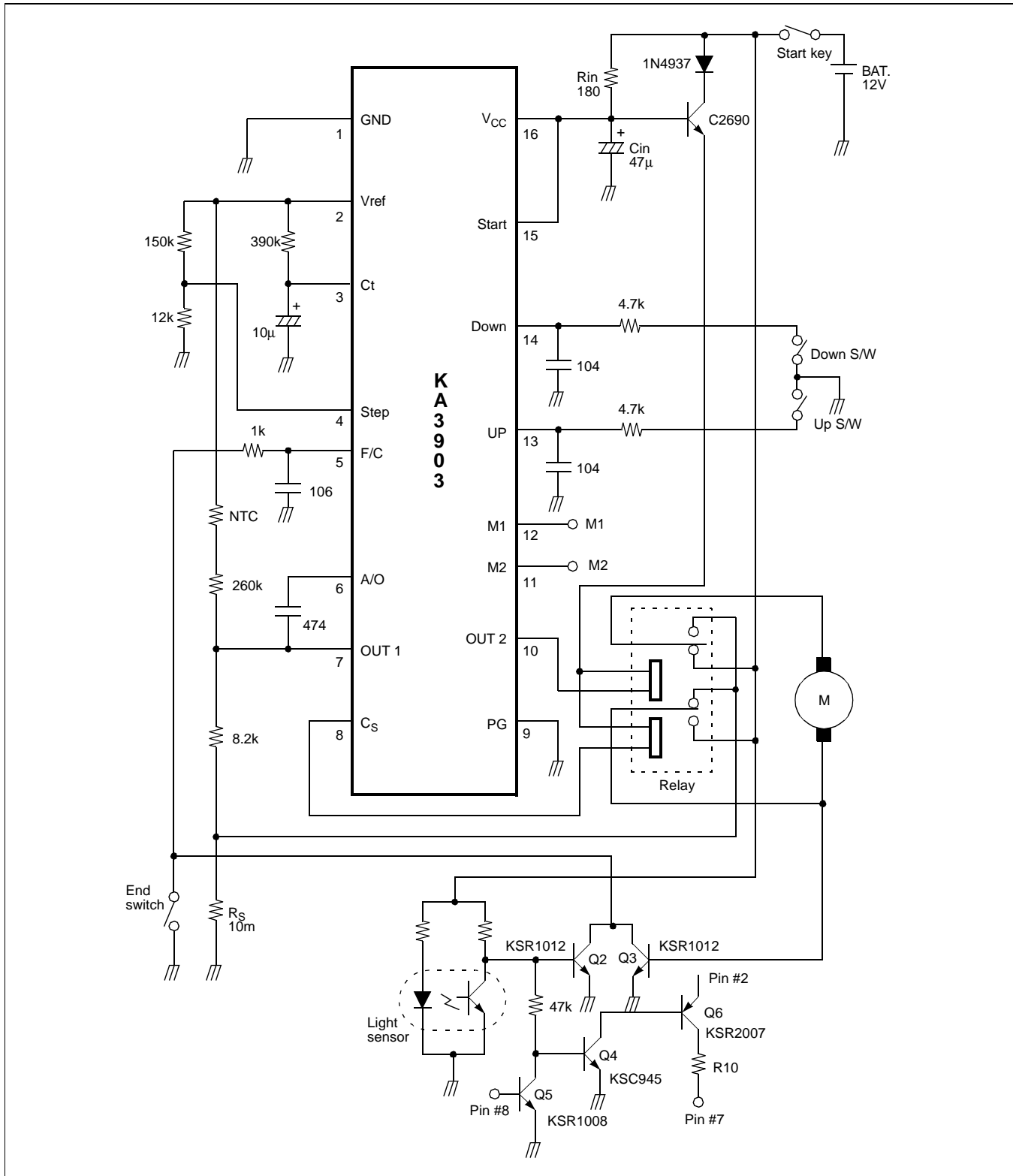

PACKAGE DIMENSION

**16-DIP-300A**

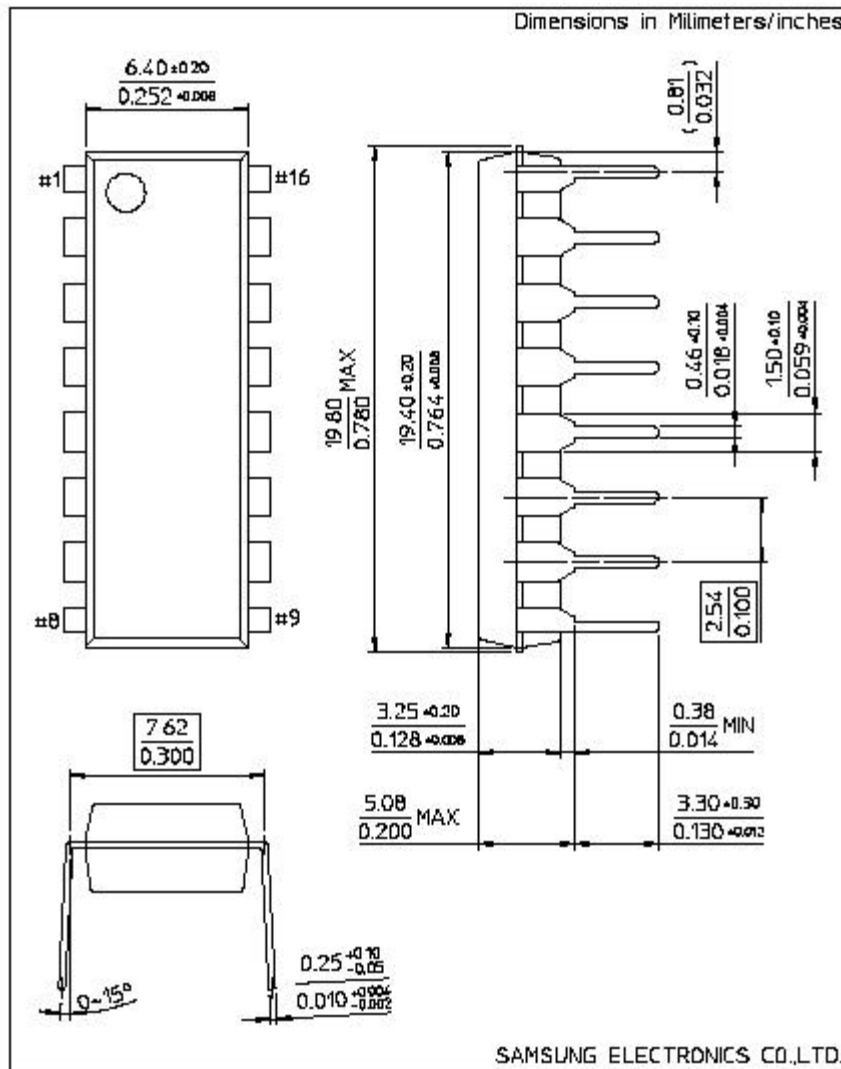

## TRADEMARKS

The following are registered and unregistered trademarks Fairchild Semiconductor owns or is authorized to use and is not intended to be an exhaustive list of all such trademarks.

ACEx™	ISOPLANAR™
CoolFET™	MICROWIRE™
CROSSVOLT™	POP™
E <sup>2</sup> CMOS™	PowerTrench™
FACT™	QS™
FACT Quiet Series™	Quiet Series™
FAST®	SuperSOT™-3
FASTr™	SuperSOT™-6
GTO™	SuperSOT™-8
HiSeC™	TinyLogic™

## DISCLAIMER

FAIRCHILD SEMICONDUCTOR RESERVES THE RIGHT TO MAKE CHANGES WITHOUT FURTHER NOTICE TO ANY PRODUCTS HEREIN TO IMPROVE RELIABILITY, FUNCTION OR DESIGN. FAIRCHILD DOES NOT ASSUME ANY LIABILITY ARISING OUT OF THE APPLICATION OR USE OF ANY PRODUCT OR CIRCUIT DESCRIBED HEREIN; NEITHER DOES IT CONVEY ANY LICENSE UNDER ITS PATENT RIGHTS, NOR THE RIGHTS OF OTHERS.

## LIFE SUPPORT POLICY

FAIRCHILD'S PRODUCTS ARE NOT AUTHORIZED FOR USE AS CRITICAL COMPONENTS IN LIFE SUPPORT DEVICES OR SYSTEMS WITHOUT THE EXPRESS WRITTEN APPROVAL OF FAIRCHILD SEMICONDUCTOR CORPORATION. As used herein:

1. Life support devices or systems are devices or systems which, (a) are intended for surgical implant into the body, or (b) support or sustain life, or (c) whose failure to perform when properly used in accordance with instructions for use provided in the labeling, can be reasonably expected to result in significant injury to the user.
2. A critical component is any component of a life support device or system whose failure to perform can be reasonably expected to cause the failure of the life support device or system, or to affect its safety or effectiveness.

## PRODUCT STATUS DEFINITIONS

### Definition of Terms

Datasheet Identification	Product Status	Definition
Advance Information	Formative or In Design	This datasheet contains the design specifications for product development. Specifications may change in any manner without notice.
Preliminary	First Production	This datasheet contains preliminary data, and supplementary data will be published at a later date. Fairchild Semiconductor reserves the right to make changes at any time without notice in order to improve design.
No Identification Needed	Full Production	This datasheet contains final specifications. Fairchild Semiconductor reserves the right to make changes at any time without notice in order to improve design.
Obsolete	Not In Production	This datasheet contains specifications on a product that has been discontinued by Fairchild semiconductor. The datasheet is printed for reference information only.