

HIGH SPEED VOLTAGE COMPARATOR

The KA710/I is a high speed voltage comparator intended for use as an accurate, low-level digital level sensor or as a replacement for operational amplifiers in comparator applications where speed is of prime importance.

The output of the comparator is compatible with all integrated logic forms.

The KA710/I is useful as pulse height discriminators, a variable threshold Schmitt trigger, voltage comparator in high-speed A/D converters, a memory sense amplifier or a high noise immunity line receiver.

FEATURES

- Low offset voltage: 5mV
- High gain: 1000 V/V
- High speed: 40ns Typ

BLOCK DIAGRAM

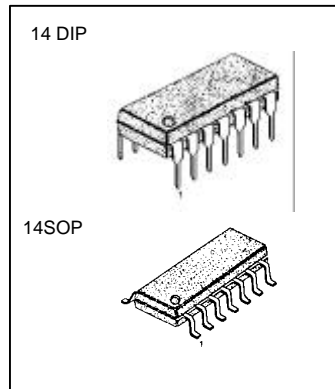
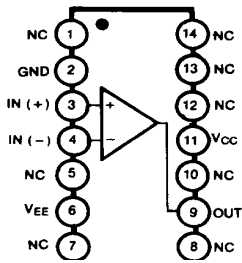

ORDERING INFORMATION

Device	Package	Operating Temperature
KA710	14 DIP	0 ~ 70°C
KA710D	14 SOP	
KA710I	14 DIP	-25 ~ 85°C
KA710ID	14 SOP	

SCHEMATIC DIAGRAM

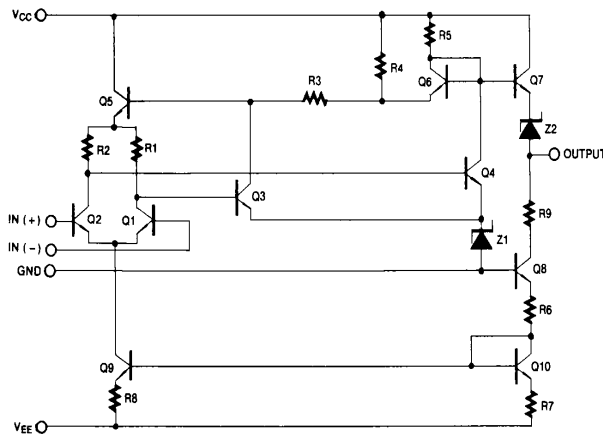

ABSOLUTE MAXIMUM RATINGS

Characteristic	Symbol	Value	Unit
Positive Supply Voltage	V_{CC}	+14	V
Negative Supply Voltage	V_{EE}	-7	V
Peak Output Current	I_{PK}	10	mA
Output Short Circuit Duration		10	Sec
Differential Input Voltage	$V_{I(DIFF)}$	5	V
Input Voltage	V_I	± 7	V
Power Dissipation	P_D	500	mW
Operating Temperature Range LM710	T_{STG}	0 ~ +70	$^{\circ}C$
LM710I		-25 ~ +85	$^{\circ}C$
Storage Temperature Range	T_{STG}	-65 ~ +150	$^{\circ}C$

ELECTRICAL CHARACTERISTICS ($V_{CC} = +12V$, $V_{EE} = -6V$, $T = 25^{\circ}C$, unless otherwise specified)

Characteristics	Symbol	Test Conditions	LM710I			LM710			UNIT
			Min	Typ	Max	Min	Typ	Max	
Input Offset voltage	V_{IO}	$R_S \leq 200\Omega$, Note1		0.6	2.0		1.6	5.0	mV
			Note 2			3.0		6.5	
Input Offset Current (Note 1)	I_{IO}	NOTE 1		0.75	3.0		1.8	5.0	nA
			Note 2		1.8	7.0		7.5	
Input Bias Current	I_{BIAS}			5.0	20		7.0	25	nA
			Note 2		27	45		25	
Large Signal Voltage Gain	G_V		1250	1800		1000	1700		V/V
			Note 2						
Input Voltage Range	$V_{I(R)}$	$V_{CC} = -7V$	± 5.0			± 5.0			V
Common Mode Rejection Ratio	CMRR	$R_S \leq 200\Omega$, NOTE 2	80	95		70	94		dB
Differential Input Voltage Range	$V_{ID(R)}$		± 5.0			± 5.0			V
Positive Output Level	$V_{O(H)}$	$0 \leq I_O \leq 5mA$, $V_I \geq 5mV$	2.5	2.9	4.0	2.5	2.9	4.0	V
Negative Output Level	$V_{O(L)}$	$V_I \geq 5mV$	-1.0	-0.5	0	-1.0	-0.5	0	V
Output Sink Current	I_{SINK}	$V_{O(P)} = 0V$, $V_I \geq 5mV$	2.0	2.2		1.6	2.2		mA
Positive Supply Current	I_{CC}	$V_{O(P)} \leq 0V$		4.7	9.0		4.7	9.0	mA
Negative Supply Current	I_{EE}	$V_{O(P)} = 0V$, $V_I = 5mV$		4.0	7.0		4.0	7.0	mA
Power Consumption	P_D	$V_{O(P)} = 0V$, $V_I = 10mV$		80	150			150	mW
Response Time	t_{RES}	(Note 3)		40			40		ns

Note 1. The input offset voltage and input offset current are specified for a logic threshold voltage as follows:
For 710I, 1.65V at $-25^{\circ}C$, 1.4V at $+25^{\circ}C$, 1.15V at $+85^{\circ}C$. For 710, 1.5V at $0^{\circ}C$, 1.4V at $+25^{\circ}C$, 1.2V at $+70^{\circ}C$.

Note 2. LM710: $0 \leq TA \leq +70^{\circ}C$
LM710I: $-25 \leq TA \leq +85^{\circ}C$

Note 3. The response time specified is a 100mV input step with 5mV overdrive (LM710).

TYPICAL PERFORMANCE CHARACTERISTICS

Fig. 1 SUPPLY CURRENT

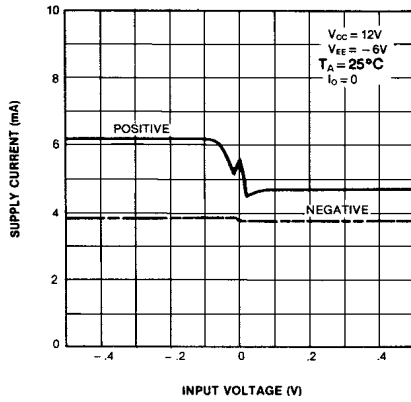

Fig. 2 VOLTAGE GAIN

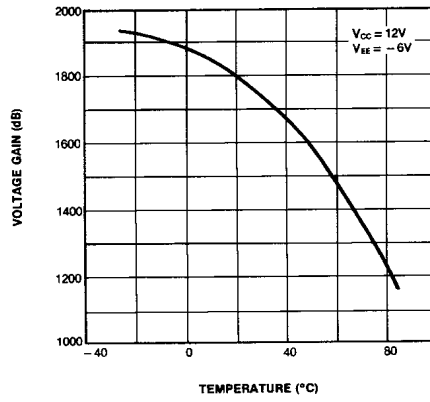

Fig. 3 INPUT OFFSET CURRENT

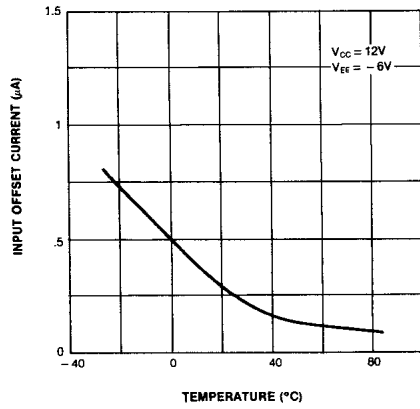

Fig. 4 INPUT BIAS CURRENT

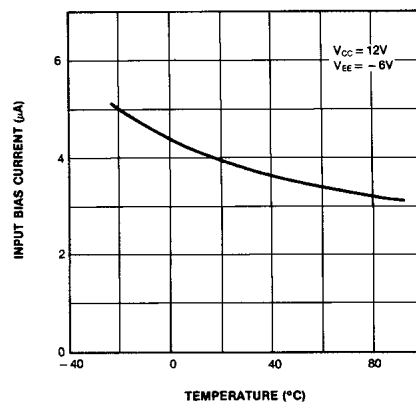

Fig. 5 OUTPUT VOLTAGE LEVEL

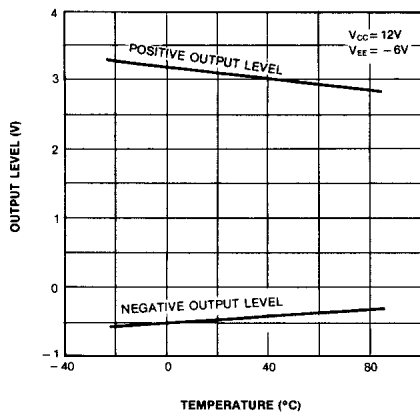
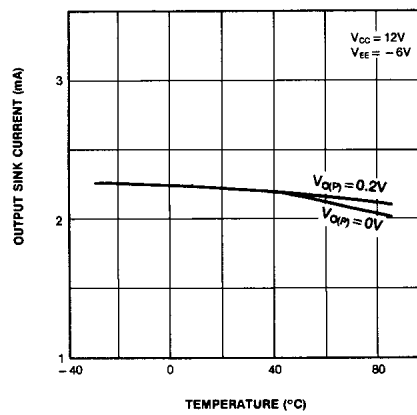

Fig. 6 OUTPUT SINK CURRENT



TRADEMARKS

The following are registered and unregistered trademarks Fairchild Semiconductor owns or is authorized to use and is not intended to be an exhaustive list of all such trademarks.

ACE _x TM	ISOPLANAR TM	TinyLogic TM
CoolFET TM	MICROWIRE TM	UHC TM
CROSSVOLT TM	POP TM	VCX TM
E ² CMOS TM	PowerTrench [®]	
FACT TM	QFET TM	
FACT Quiet Series TM	QS TM	
FAST [®]	Quiet Series TM	
FAST _r TM	SuperSOT TM -3	
GTO TM	SuperSOT TM -6	
HiSeC TM	SuperSOT TM -8	

DISCLAIMER

FAIRCHILD SEMICONDUCTOR RESERVES THE RIGHT TO MAKE CHANGES WITHOUT FURTHER NOTICE TO ANY PRODUCTS HEREIN TO IMPROVE RELIABILITY, FUNCTION OR DESIGN. FAIRCHILD DOES NOT ASSUME ANY LIABILITY ARISING OUT OF THE APPLICATION OR USE OF ANY PRODUCT OR CIRCUIT DESCRIBED HEREIN; NEITHER DOES IT CONVEY ANY LICENSE UNDER ITS PATENT RIGHTS, NOR THE RIGHTS OF OTHERS.

LIFE SUPPORT POLICY

FAIRCHILD'S PRODUCTS ARE NOT AUTHORIZED FOR USE AS CRITICAL COMPONENTS IN LIFE SUPPORT DEVICES OR SYSTEMS WITHOUT THE EXPRESS WRITTEN APPROVAL OF FAIRCHILD SEMICONDUCTOR CORPORATION.
As used herein:

1. Life support devices or systems are devices or systems which, (a) are intended for surgical implant into the body, or (b) support or sustain life, or (c) whose failure to perform when properly used in accordance with instructions for use provided in the labeling, can be reasonably expected to result in significant injury to the user.
2. A critical component is any component of a life support device or system whose failure to perform can be reasonably expected to cause the failure of the life support device or system, or to affect its safety or effectiveness.

PRODUCT STATUS DEFINITIONS

Definition of Terms

Datasheet Identification	Product Status	Definition
Advance Information	Formative or In Design	This datasheet contains the design specifications for product development. Specifications may change in any manner without notice.
Preliminary	First Production	This datasheet contains preliminary data, and supplementary data will be published at a later date. Fairchild Semiconductor reserves the right to make changes at any time without notice in order to improve design.
No Identification Needed	Full Production	This datasheet contains final specifications. Fairchild Semiconductor reserves the right to make changes at any time without notice in order to improve design.
Obsolete	Not In Production	This datasheet contains specifications on a product that has been discontinued by Fairchild semiconductor. The datasheet is printed for reference information only.