

**KA7525/B/26****POWER FACTOR CORRECTION**

The KA7525/B/26 provides simple, yet high performance active power factor correction. KA7525/B/26 is optimized for electronic ballast and low power, high density power supplies requiring a minimum board area, reduced component count and low power dissipation. Addition of internal current sense blanking eliminates the need for an external R/C filter.

Internal clamping of the error amplifier and multiplier outputs improves turn on overshoot characteristics and current limiting. Special circuitry has also been added to prevent no load runaway conditions. Output drive clamps limiting power MOSFET gate drive independent of supply voltage greatly enhance the products practical application.

**FEATURES**

- Internal Startup Timer
- Internal Current Sense Blanking which eliminates the Need for an External R/C filter
- Overvoltage Comparator eliminates Runaway Output Voltage
- Zero Current Detector
- One Quadrant Multiplier
- Trimmed 1.5% Internal Bandgap Reference
- Under Voltage Lock Out with 2V of Hysteresis
- Totem Pole Output with High State Clamp
- Low Startup and Operating Current
- 8-Pin Dual In-line Package or 8-Pin SOP

**APPLICATIONS**

- Electronic Ballast
- SMPS

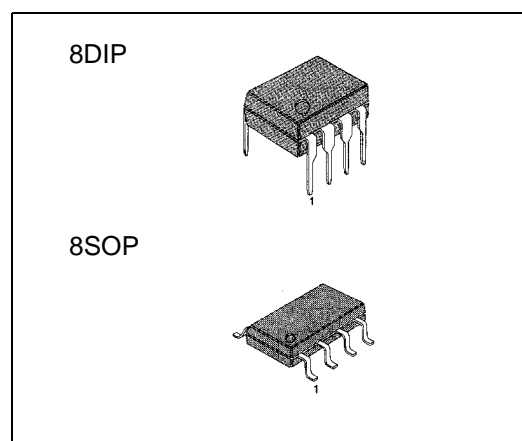
**ORDERING INFORMATION**

Device	Package	Operating Temperature
KA7525/B/26	8DIP	0 ~ +125°C
KA7525D/BD/26D	8SOP	

BLOCK DIAGRAM

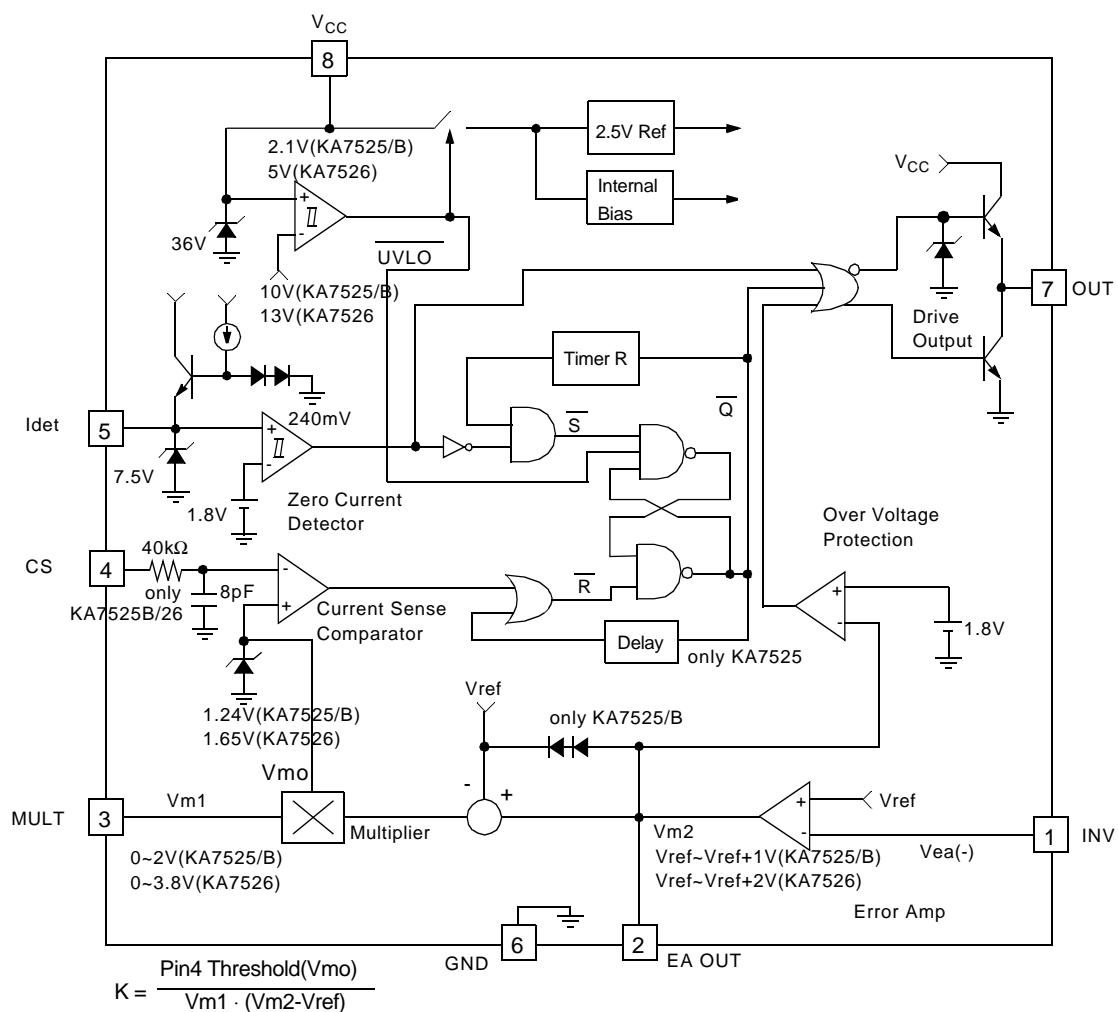

IC SELECTION GUIDE

Function	Option	KA7525/B	KA7526
UVLO		7.9/10V	8/13V
Multiplier Input Range (Vm1)		0 ~ 2V	0 ~ 3.8V
Multiplier INput Range (Vm2)		Vref ~ Vref + 1V	Vref ~ Verf + 2V
Maximum Current Sense Voltage		1.24V	1.65V

## PIN CONNECTIONS

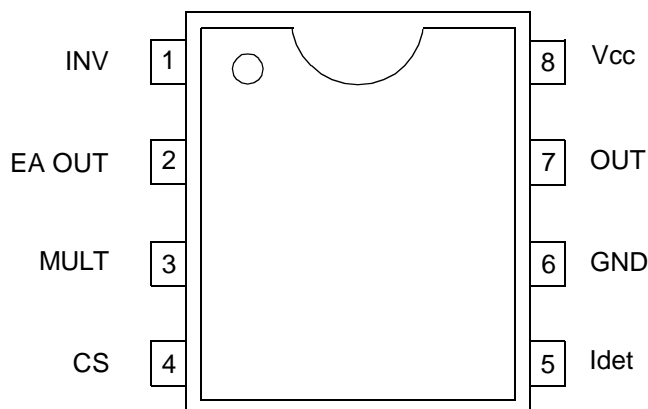

(Top View)

## PIN FUNCTIONS

No.	Name	Function
1	INV	Inverting input of the error amplifier. The output of the boost converter should be resistively divided to 2.5V and connected to this pin.
2	EA OUT	The output of the error amplifier. A feedback compensation network is placed between this pin and the INV pin
3	MULT	Input to the multiplier stage. The full-wave rectified AC is divided to less than 2V and is connected to this pin.
4	CS	Input to the PWM comparator. Current is sensed in the boost stage Mosfet by a resistor in the source lead. An internal leading edge blanking circuitry has been included to reject any high frequency noise present on the current waveform.
5	Idet	The zero current detector senses the inductor current by monitoring when the boost inductor auxiliary winding voltage falls below 1.8V.
6	GND	The ground potential of all the pins.
7	OUT	The output of a high-current power driver capable of driving the gate of a power MOSFET.
8	V <sub>CC</sub>	The logic and control power supply connection.

**MAXIMUM RATINGS**

Characteristics	Symbol	Value	Units
Supply voltage	$V_{CC}$	30	V
Peak drive output current	$I_{OH}, I_{OI}$	$\pm 500$	mA
Driver output clamping diodes $V_O > V_{CC}$ or $V_O < -0.3V$	$I_{clamp}$	$\pm 10$	mA
Detector clamping diodes	$I_{det}$	$\pm 3$	mA
Error amp, multiplier and comparator input voltage	$V_{IN}$	-0.3 to 6	V
Operating temperature range <sup>(note)</sup>	$T_{opr}$	0 to 125	°C
Storage temperature range	$T_{stg}$	-65 to 150	°C
Power dissipation <sup>(note)</sup>	$P_d$	0.8	W
Thermal resistance <sup>(note)</sup> (Junction-to-air)	$\theta_{ja}$	100	°C/W

**NOTE:** Based in 8 DIP**MAXIMUM RATINGS**( $0^{\circ}C \leq T_a \leq 125^{\circ}C$ )

Characteristics	Symbol	Value	Units
Temperature stability for reference voltage( $V_{ref}$ )	$\Delta V_{ref}$ (Typ)	20	mV
Temperature stability for multiplier gain(K)	$\Delta K/\Delta T$ (Typ)	-0.2	%/°C

## ELECTRICAL CHARACTERISTICS

Unless otherwise specified, these specifications apply over the operating ambient temperatures for the KA7525/B/26 with  $0^{\circ}\text{C} \leq T_a \leq 125^{\circ}\text{C}$  and  $V_{CC}=12\text{V}$ .

Characteristics	Symbol	Test Condition	Min.	Typ.	Max.	Units	
<b>UNDER VOLTAGE LOCK OUT SECTION</b>							
Start threshold voltage	KA7525/B	Vth (st)	V <sub>CC</sub> Increasing	9	10	11	V
	KA7526			12	13	14	
UVLO hysteresis	KA7525/B	HY(st)	-	1.7	2.1	2.5	V
	KA7526			4	5	6	
Supply zener voltage	Vz	I <sub>CC</sub> =10mA	30	36	-	V	
<b>SUPPLY CURRENT SECTION</b>							
Start up supply current	KA7525/B	Ist	V <sub>CC</sub> <Vth(st)	-	0.2	0.3	mA
	KA7526			-	0.3	0.4	
Operating supply current	I <sub>CC</sub>	Output not switching	-	4	8	mA	
Dynamic operating supply current	I <sub>dcc</sub>	50kHz, Cl=1nF	-	5	10	mA	
<b>ERROR AMPLIFIER SECTION</b>							
Voltage feedback input threshold	Vref	Iref=0mA	2.465	2.5	2.535	V	
		0≤Ta≤125°C	2.44	-	2.56	V	
Line regulation	ΔVref1	12V≤V <sub>CC</sub> ≤25V	-	0.1	10	mV	
Load regulation (note1)	ΔVref2	0mA≤Iref≤2mA	-	0.1	10	mV	
Temperature stability of vref (note2)	ΔVref3	0≤Ta≤125°C	-	20	-	mV	
Input bias current	Ib(ea)	-	-0.5	-	0.5	μA	
Output source current	Isource	Vm2=3V	-2	-4.5	-	mA	
Output sink current	Isink	Vm2=2V	3	4.5	-	mA	
Output voltage range (note2)	ΔVeao	No Load on E.A Output	1.2	-	3.6	V	
Slew rate	SR	-	-	0.6	-	V/μs	

## ELECTRICAL CHARACTERISTICS(Continued)

Characteristics	Symbol	Test Condition	Min.	Typ.	Max.	Units	
<b>MULTIPLIER SECTION</b>							
Input bias current(pin3)	lb(m)	-	-0.5	-	0.5	μA	
M1 input voltage range (pin3)	KA7525/B	ΔVm1	-	0	-	2	V
	KA7526			0	-	3.8	
M2 input voltage range (pin2)	KA7525/B	ΔVm2	-	Vref	-	Vref +1	V
	KA7526			Vref	-	Vref +2	
Multiplier gain (note3)	K	Vm1=1V, ΔVm2=2.7 to 3.3V	0.55	0.68	0.8	1/V	
Maximum multiplier output voltage	KA7525/B	Vomax(m)	Vea(-)=0V, Vm1=2V	1.1	1.24	1.45	V
	KA7526			1.5	1.65	1.8	
Temperature stability of k (note2)	ΔK/ΔT	0≤Ta≤125°C	-	-0.2	-	%/°C	
<b>CURRENT SENSE SECTION</b>							
Input offset voltage (note2)	Vio(cs)	Vm1=0V, Vm2=2.2V	-10	3	10	mV	
Input bias current	lb(cs)	0V≤V <sub>CC</sub> ≤1.7V	-1	-0.3	1	μA	
CUrrent sense delay to output (note2)	td(cs)	-	-	200	500	ns	
Current sense blanking time(note2) (only KA7525)	tblk(cs)	-	0.4	0.9	1.2	ms	
<b>DETECT SECTION</b>							
Detect input threshold	Vth(det)	Vdet Increasing	1.65	1.8	1.95	V	
Detect hysteresis	HY(det)	-	180	240	300	mV	
Input low clamp voltage	Vclamp(l)	Idet=-100uA	0.45	0.75	1	V	
Input high clamp voltage	Vclamp(h)	Idet=3mA	6.7	7.5	8.3	V	
Input bias current	lb(det)	1V≤Vdet≤6V	-1	-0.2	1	μA	
Input high/low clamp diode current (note2)	Iclamp	-	-	-	± 3	mA	

## ELECTRICAL CHARACTERISTICS(Continued)

CHARACTERISTICS	SYMBOL	TEST CONDITION	MIN	TYP	MAX	UNITS
<b>OUTPUT DRIVER SECTION</b>						
Output voltage high	V <sub>OH</sub>	I <sub>O</sub> =-10mA, V <sub>CC</sub> =12V	8.5	9	-	V
Output voltage low	V <sub>OL</sub>	I <sub>O</sub> =10mA, V <sub>CC</sub> =12V	-	0.8	1	V
Rising time (note2)	tr	Cl=1nF	-	130	200	ns
Falling time (note2)	tf	Cl=1nF	-	50	120	ns
Maximum output voltage	V <sub>omax(o)</sub>	V <sub>CC</sub> =20V	12	13	15	V
Output voltage with uvlo activated	V <sub>omin(o)</sub>	V <sub>CC</sub> =5V, I <sub>O</sub> =100μA	-	-	1	V
<b>RESTART TIMER SECTION</b>						
Restart time delay	td(rst)	V <sub>m1</sub> =1V, V <sub>m2</sub> =3.5V	-	300	-	μs
<b>OVERVOLTAGE PROTECTION SECTION</b>						
Voltage feedback input threshold	V <sub>th(ovp)</sub>	V <sub>cs</sub> =-0.5V, V <sub>m1</sub> =1V V <sub>det</sub> =0V	1.7	1.8	1.9	V

NOTE : 1. Because the reference is not brought out externally, this specification cannot be tested on the package part. It is guaranteed by design.

2. This parameter, although guaranteed, is not tested in production.

$$3. K = \frac{\text{Pin4 Threshold}}{V_{m1} \times (V_{m2} - V_{ref})} \quad (V_{m1} = V_{pin3}, V_{m2} = V_{pin2})$$

TYPICAL PERFORMANCE CHARACTERISTICS

Fig1. E.A. Output Voltage vs C.S. Threshold

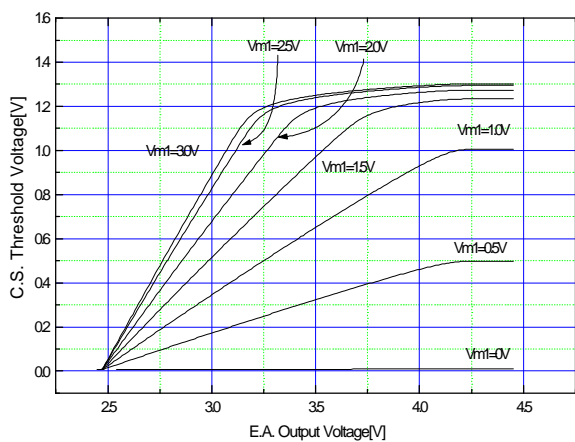

Fig2. Multiplier Input Voltage vs C.S. Threshold

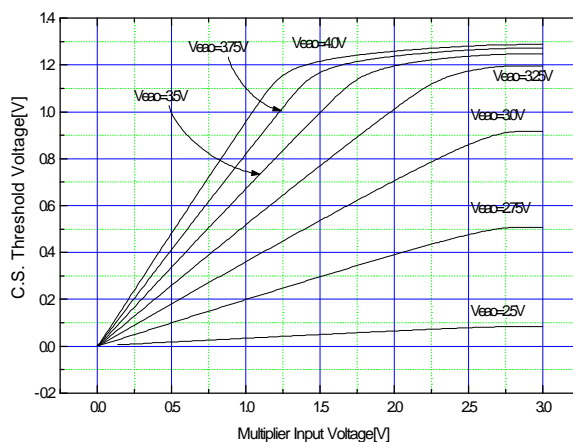

Fig3. Supply Current vs Supply Voltage

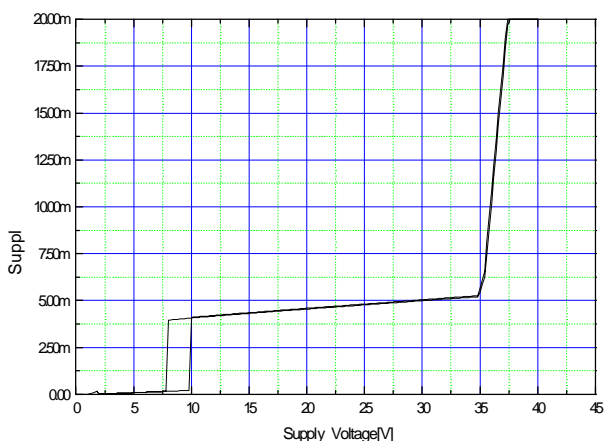

Fig4. Reference Voltage vs Temperature

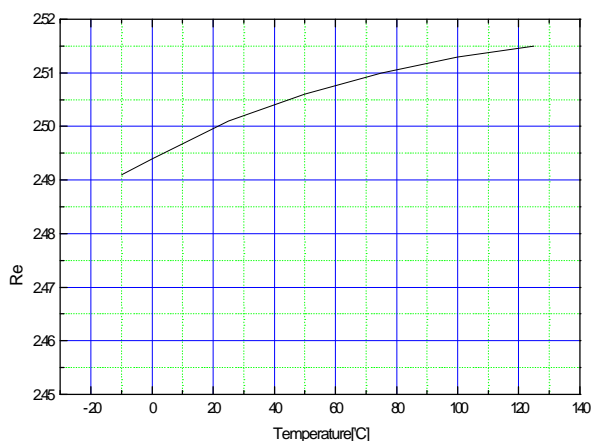

Fig5. Start-up Threshold vs Temperature

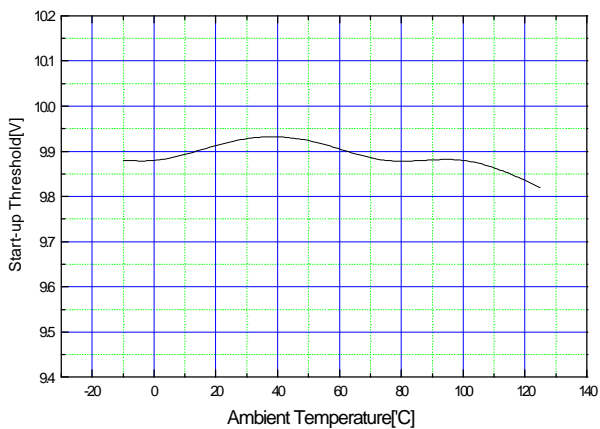

Fig6. UV Lockout Hysteresis vs Temperature

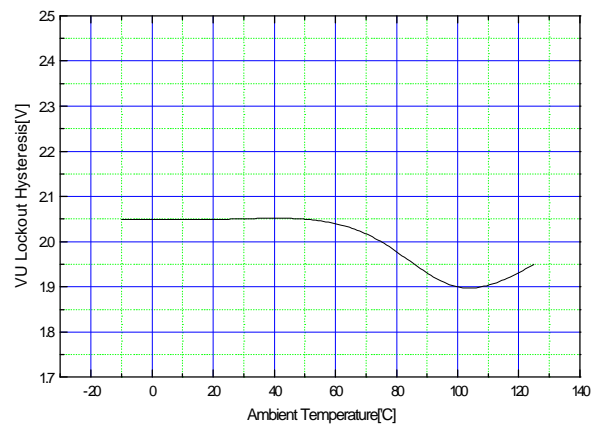

Fig.7 Start-up Supply Current vs Temperature

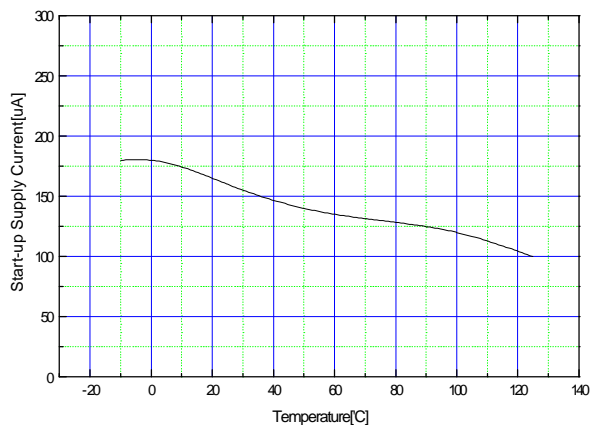

Fig.8 E.A. Source Current vs Temperature

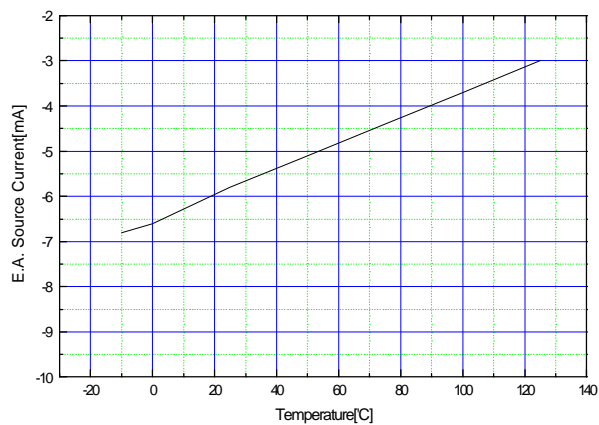

Fig.9 E.A. Sink Current vs Temperature

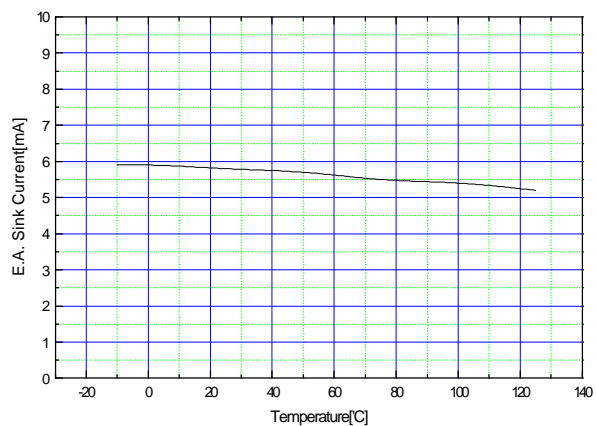

Fig.10 E.A. Input Bias Current vs Temperature

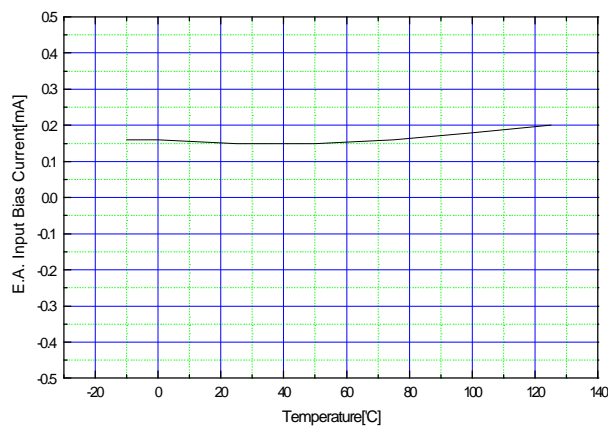

Fig.11 Multiplier Gain vs Temperature

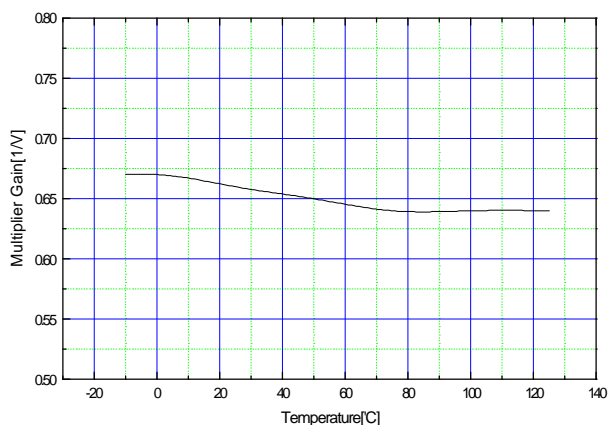

Fig.12 Idet Threshold High vs Temperature

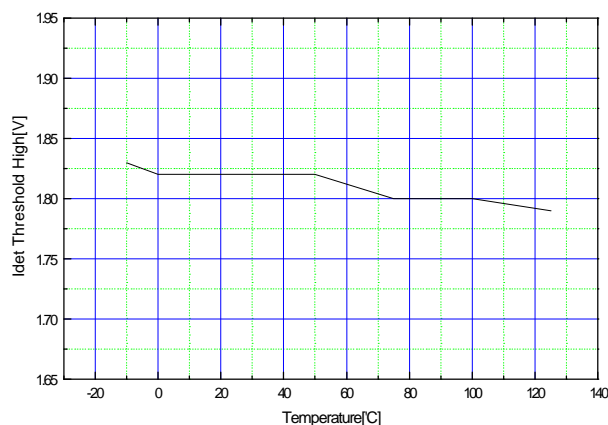

Fig.13 Idet Input Hysteresis vs Temperature

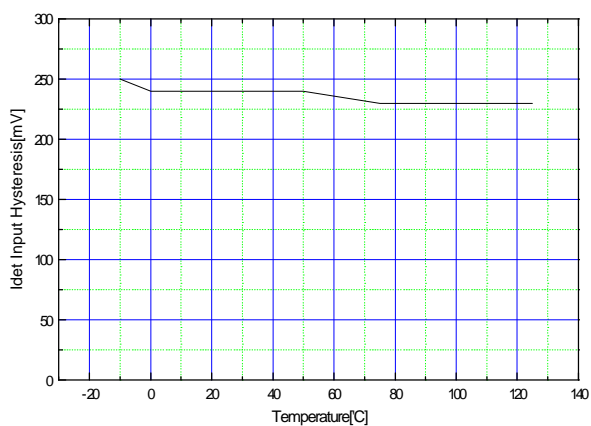

Fig.14 Restart Time vs Temperature

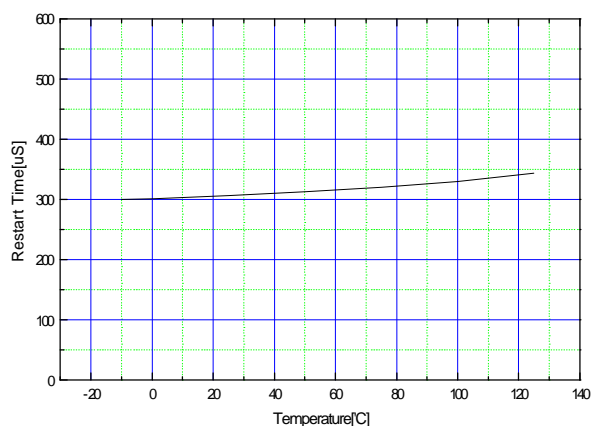

Fig.15 Max. Mult. Output Voltage vs Temperature

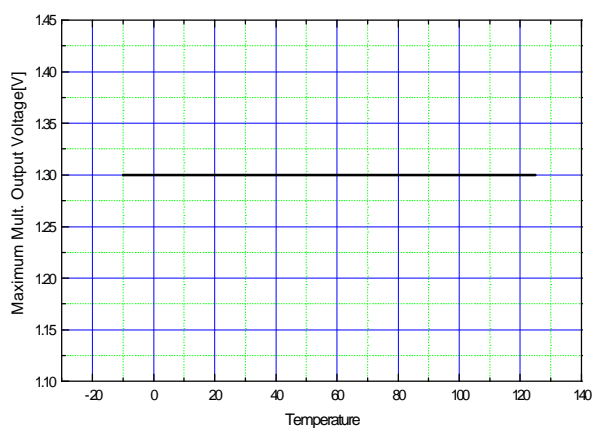

Fig.16 Rise Time vs Temperature

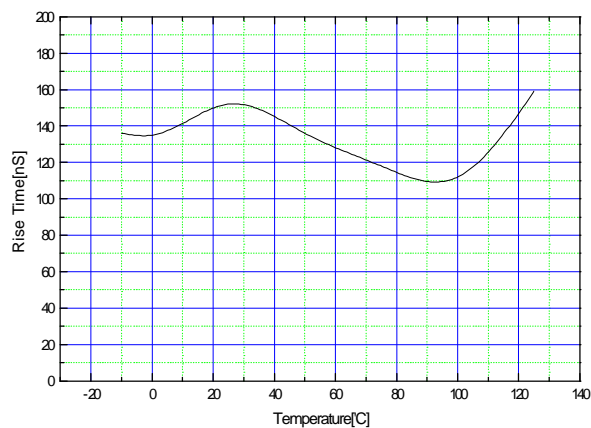

Fig.17 Fall Time vs Temperature

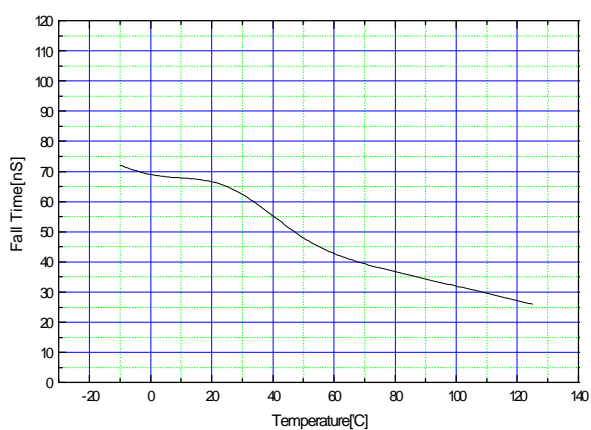
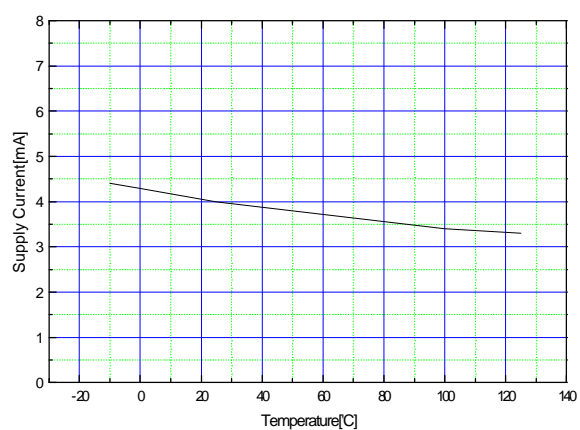

Fig.18 Supply Current vs Temperature



## OPERATING DESCRIPTION

KA7525/B/26 is high performance, critical conduction, current-mode power factor controller specifically designed for use in off-line active preconverters with minimal external components. This device provides the necessary features required to significantly enhance poor power factor loads by keeping the ac line current sinusoidal and in phase with the line voltage.

KA7525/B/26 contains many of the building blocks and protection features that are employed in modern high performance current mode power supply controllers. A description of each of the function blocks is given below.

## START-UP

An Undervoltage Lockout comparator has been incorporated to guarantee that IC is fully functional before enabling the output stage. The positive power supply terminal ( $V_{cc}$ ) is monitored by the UVLO comparator with the upper threshold set at 10V (13V: KA7526) and the lower threshold at 7.9V. In the stand-by mode, with  $V_{cc}$  at 9.5V (12.5V:KA7526), the required supply current is less than 0.2mA (0.3mA:KA7526). This large hysteresis and low start-up current allow the implementation of efficient bootstrap start-up techniques, making this device ideally suited for wide range off-line pre-converter applications.

Fig.1.1 shows the start-up circuit. Circuit operation is as follows:

The start-up capacitor ( $C_{st}$ ) is charged by current through start-up resistor ( $R_{st}$ ) minus the start-up current drawn by the IC. Once the capacitor voltage reaches the start-up threshold, the IC turns on, starting the switching of the MOSFET. The operation of the IC demands an increase in operating current which results in discharging the capacitor. Before the start-up capacitor voltage is discharged below hysteresis voltage, the auxiliary winding voltage takes over as the supply voltage as shown in Fig. 1.2.

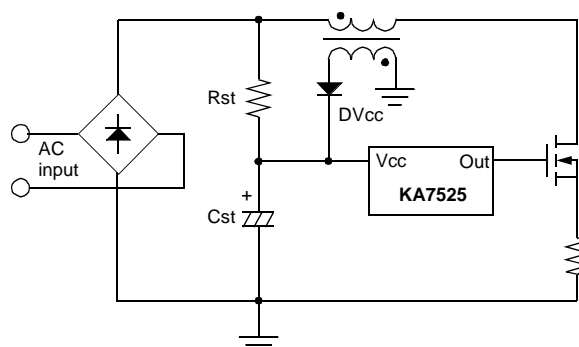

Fig.1.1 Start-up Circuit

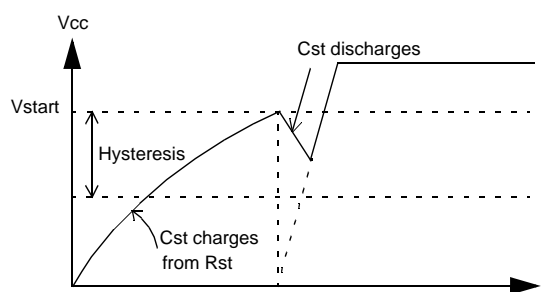

Fig.1.2 Start-up Capacitor Voltage

## ERROR AMPLIFIER

An Error Amplifier with access to the inverting input and output is provided. The noninverting input is internally biased at 2.5V and is not pinned out. The output voltage of the power factor converter is typically divided down and monitored by the inverting input. The error amp output is internally connected to the multiplier and is pinned out for external loop compensation. Typically, the bandwidth is set below 20Hz, so that the amplifier's output voltage is relatively constant over a given ac line cycle. In effect, the error amp monitors the average output voltage of the converter over several line cycles. Input bias current (0.5uA, max) can cause an output voltage error that is equal to the product of the input bias current and the value of the upper divider resistor,  $R_1$  in Fig. 2.1.

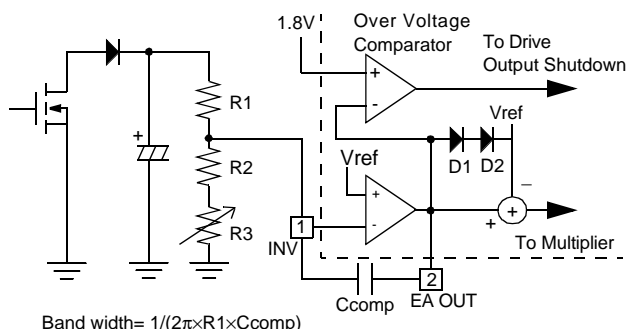

Fig.2.1 Error Amp and Over Voltage Comparator

The multiplier output controls the current sense comparator threshold as the ac voltage traverses sinusoidally from zero to peak line. This allows the inductor peak current to follow the ac line thus forcing the average input current to be sinusoidal. In other words, this has the effect of forcing the MOSFET on-time to track the input line voltage, resulting in a fixed drive output on-time, thus making the preconverter load appear to be resistive to the ac line.

The equation below describes the relationship between multiplier output and inputs.

$$V_{mo} = K \times V_{m1} \times (V_{m2} - V_{ref})$$

- K : Multiplier gain
- $V_{m1}$ : Voltage at Pin 3
- $V_{m2}$ : Error amp output voltage
- $V_{mo}$ : Multiplier output voltage

## OVER VOLTAGE PROTECTION

The low bandwidth (typically below 20Hz) characteristic of Error Amplifier control loop results in output voltage runaway condition. This condition can occur during initial start-up, sudden load removal, or during output arcing. The over voltage comparator monitors the output voltage of the error amplifier. When load is removed, error amp output swings lower than 1.8V, comparator is triggered high and output driver is turned off till the error amp inverting input voltage drops below 2.5V. At this point, the error amp output swings positive, turns the output driver back on. The diode, D1,D2 clamp the error amp output voltage to two diode drops above reference voltage. This prohibits the error amplifier from being saturated, allowing it to recover faster thus minimizing the boost voltage overshoot.

## MULTIPLIER

A single quadrant, two input multiplier is the critical element that enables this device to get power factor correction. One input of multiplier (Pin 3) is connected to an external resistor divider monitoring the rectified ac line. The other input is internally driven by a DC voltage which is the difference of error amplifier output (Pin 2) and reference voltage,  $V_{ref}$ . The multiplier is designed to have an extremely linear transfer curve over a wide dynamic range, 0V to 2V (3.8V: KA7526) for Pin 3, and 2.5V to 3.5V (4.5V: KA7526) for error amplifier output under all line and load conditions.

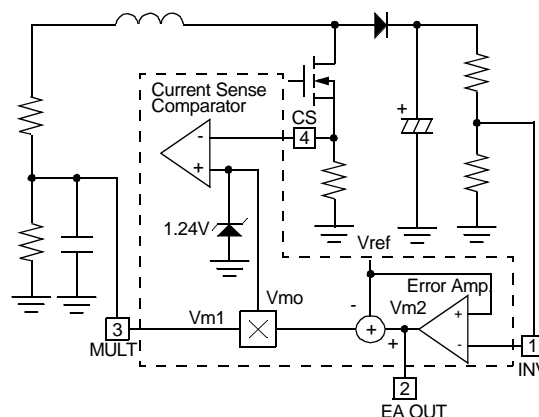

Fig.3.1 Multiplier Block

## CURRENT SENSE COMPARATOR

The current sense comparator RS latch configuration used ensures that only a single pulse appears at the drive output during a given cycle. MOSFET drain current is converted to voltage using an external sense resistor in series with the external power MOSFET. When sense voltage exceeds the threshold set by the multiplier output, the current sense comparator terminates the gate drive to the MOSFET and resets the PWM latch. The latch insures that the output remains in a low state after the MOSFET drain current falls back to zero.

The peak inductor current under normal operating conditions is controlled by the multiplier output,  $V_{mo}$ . Abnormal operating conditions occur during precon

verter start-up at extremely high line or if output voltage sensing is lost.

Under these conditions, the multiplier output and current sense threshold will be internally clamped to 1.24V(1.65V:KA7526). Therefore, the maximum peak switch current is limited to:

$$I_{pk(max)} = 1.24V / R_{sense}$$

A leading edge blanking circuit has been included to attenuate any high frequency noise that may be present on the current waveform. This circuit block eliminates the need for an external RC filter otherwise required for proper operation of the circuit.

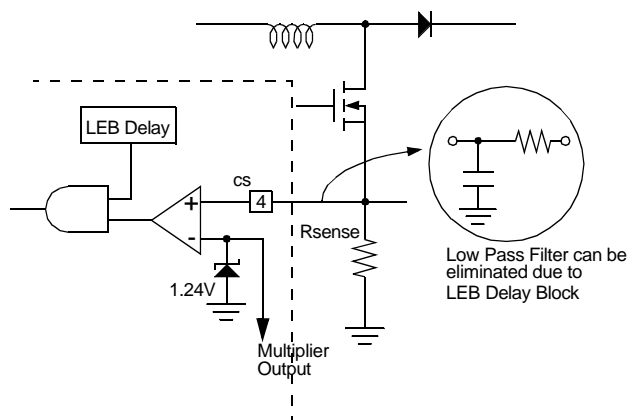

Fig. 4.1 Current Sense Circuit

substrate injection. An internal current limit resistor protects the lower clamp transistor in case the  $I_{det}$  pin is accidentally shorted to ground.

A watchdog timer function was added to the IC to eliminate the need for an external oscillator when used in stand-alone applications. The timer provides a means to automatically start or restart the preconverter if the drive output has been off for more than 300 $\mu$ s after the inductor current reaches zero.

## DRIVE OUTPUT

The KA7525/B/26 contains a single totem-pole output stage specifically designed for direct drive of power MOSFET. The drive output is capable of up to 500mA peak current with a typical rise and fall time of 130ns, 50ns each with a 1.0nF load. Additional internal circuitry has been added to keep the drive output in a sinking mode whenever the UVLO is active. This characteristic eliminates the need for an external gate pull-down resistor. Internal voltage clamping ensures that output driver is always lower than 13V when supply voltage variation exceeds more than rated  $V_{gs}$  threshold (typ 20V) of the external MOSFET. This eliminates an external zener diode and extra power dissipation associated with it that otherwise is required for reliable circuit operation.

## ZERO CURRENT DETECTOR

KA7525/B/26 operates as a critical conduction current mode controller. The power MOSFET is turned on by the zero current detector and turned off when the peak inductor current reaches the threshold level established by the multiplier output. The slope of the inductor current is indirectly detected by monitoring the voltage across a separate winding and connecting it to the zero current detector Pin 5.

Once the inductor current reaches ground level, the voltage across the winding reverses polarity. When the  $I_{det}$  input falls below 1.8V, the comparator output is triggered to the low state.

To prevent false tripping, 240mV of hysteresis is provided. The zero current detector input is internally protected by two clamps.

The upper 7.5V clamp prevents input over voltage breakdown while the lower 0.75V clamp prevents

APPLICATION CIRCUIT #1 (using KA7525/B)

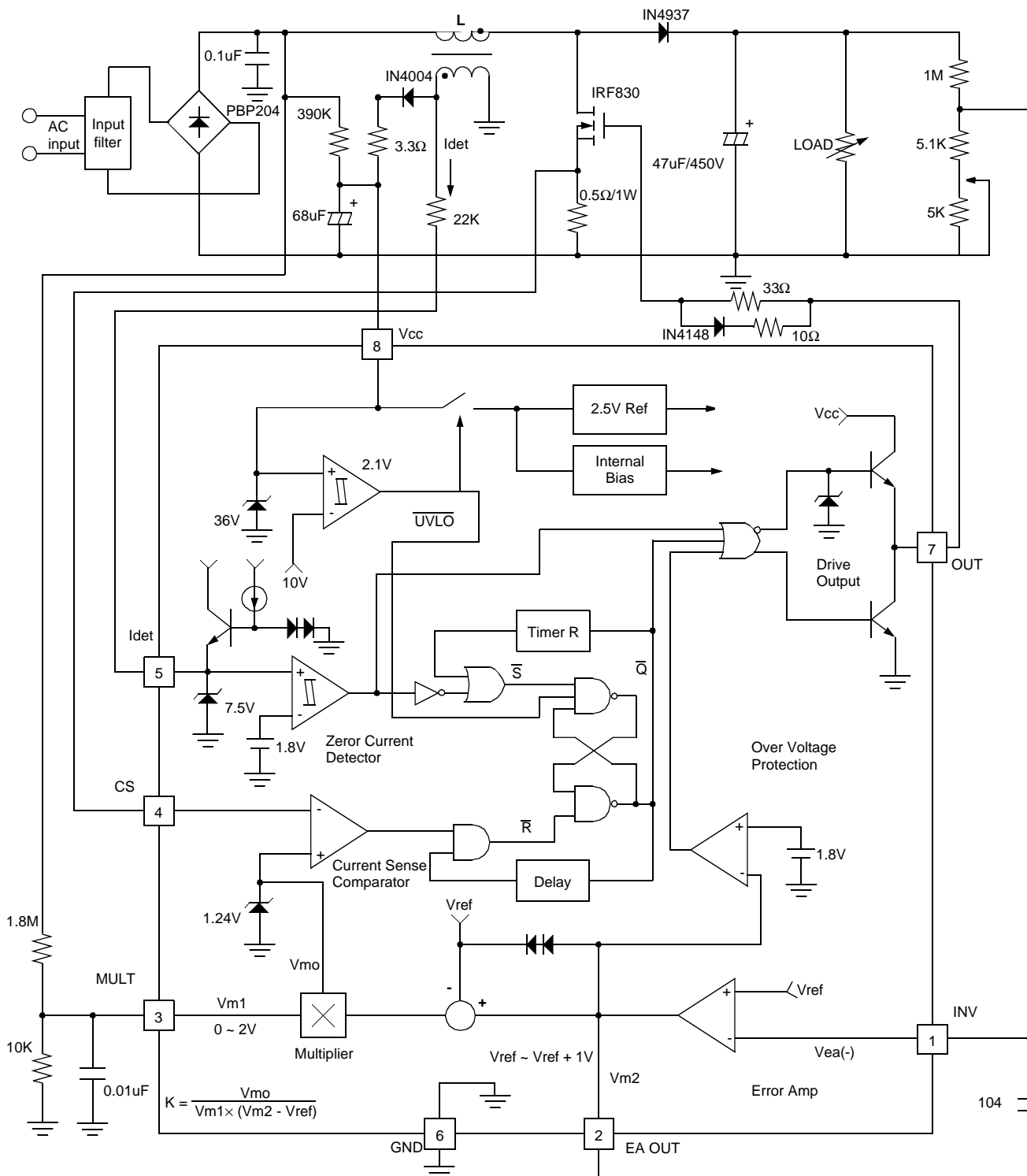

APPLICATION CIRCUIT #2 (using KA7526)

< 90 ~ 265V<sub>AC</sub> Input, 400V<sub>DC</sub>, 32W×2 Lamps Self-oscillating Ballast >

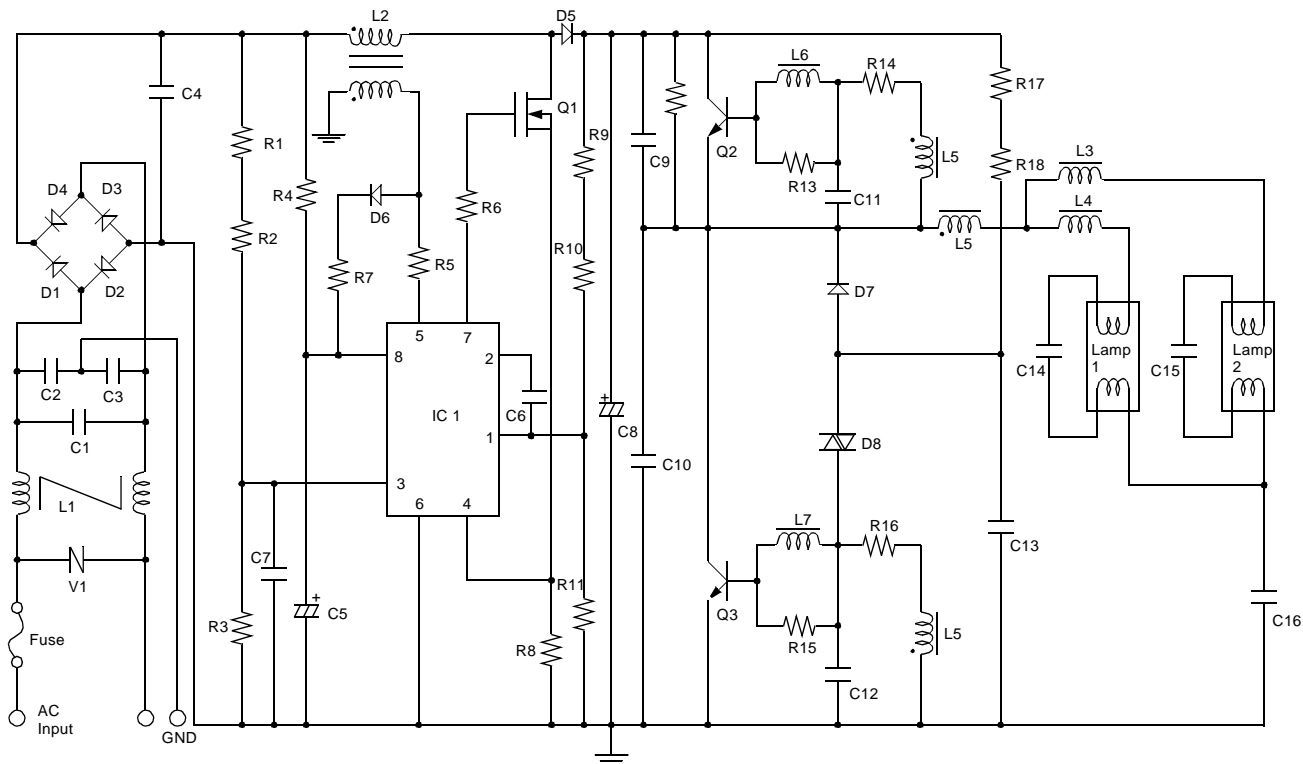

## COMPONENT LISTING (for Application circuit #2)

Reference	Value	Part Number	Manufacturer
R1, 2	1.1M $\Omega$ -F, 1/4W	26mm Type	ABCO
R3	11k $\Omega$ -F, 1/4W	26mm Type	ABCO
R4	130k $\Omega$ , 1/2W	26mm Type	ABCO
R5	22k $\Omega$ -J, 1/4W	26mm Type	ABCO
R6, 13, 15	47 $\Omega$ -J, 1/4W	26mm Type	ABCO
R7	3.3 $\Omega$ , 1/4W	26mm Type	ABCO
R8	1 $\Omega$ -J, 1W	26mm Type	ABCO
R9	180k $\Omega$ -F, 1/4W	26mm Type	ABCO
R10	820k $\Omega$ -F, 1/4W	26mm Type	ABCO
R11	6.8k $\Omega$ -F, 1/4W	26mm Type	ABCO
R12, 17, 18	390k $\Omega$ -J, 1/4W	26mm Type	ABCO
R14, 16	8.2 $\Omega$ -J, 1/4W	26mm Type	ABCO
C1	0.15 $\mu$ F, 630V	MEP-CAP	WOORYANG
C2, 3	2200pF, 3000V	Y-CAP	SAMSUNG
C4	0.22 $\mu$ F, 630V	MPE-CAP	WOORYANG
C5	22 $\mu$ F, 35V	Electrolytic	SAMSUNG
C6	0.22 $\mu$ F, 25V	Ceramic	DONGIL
C7	1000pF, 50V	Ceramic	DONGIL
C8	47 $\mu$ F, 450V	Electrolytic	SAMSUNG
C9	4700pF, 630V	PPF-CAP	WOORYANG
C10	2200pF, 630V	PPF-CAP	WOORYANG
C11, 12	0.15 $\mu$ F, 63V	MPF-CAP	YU CHANG
C13	0.1 $\mu$ F, 50V	Ceramic	DONGIL
C14, 15	8200pF, 1000V	PP-CAP	WOORYANG
C16	0.15 $\mu$ F, 630V	MEP-CAP	WOORYANG
D1, 2, 3, 4, 7	1000V, 1A	IN4007GP	GI
D5	1000V, 1.5A	RGP15J	GI
D6	75V, 150mA	IN4148	ROHM

## COMPONENT LISTING(Continued)

D8	-	N413N (DIAC)	NEC
L1	DR 10×12	DIT-010	NAMYANG
L2	EI 2519	DBT-002	NAMYANG
L3, 4	EI 2820	DPT-086	NAMYANG
L5	SB5S 8×3×4	DDT-005	NAMYANG
L6, 7	10uH	BS24-100K	NAMYANG
Fuse		52NM250V, 3A	SAMSUNG
V1	430V	INR140, 431	ILJIN
IC1		KA7526	SAMSUNG
Q1	500V, 4.5A	IRF830	SAMSUNG
Q2, 3	400V, 5A	KSC5305D	SAMSUNG

APPLICATION CIRCUIT #2 (using KA7526)

< 90 ~ 265V<sub>AC</sub> Input, 400V<sub>DC</sub>, 32W×2 Lamps Self-oscillating Ballast >

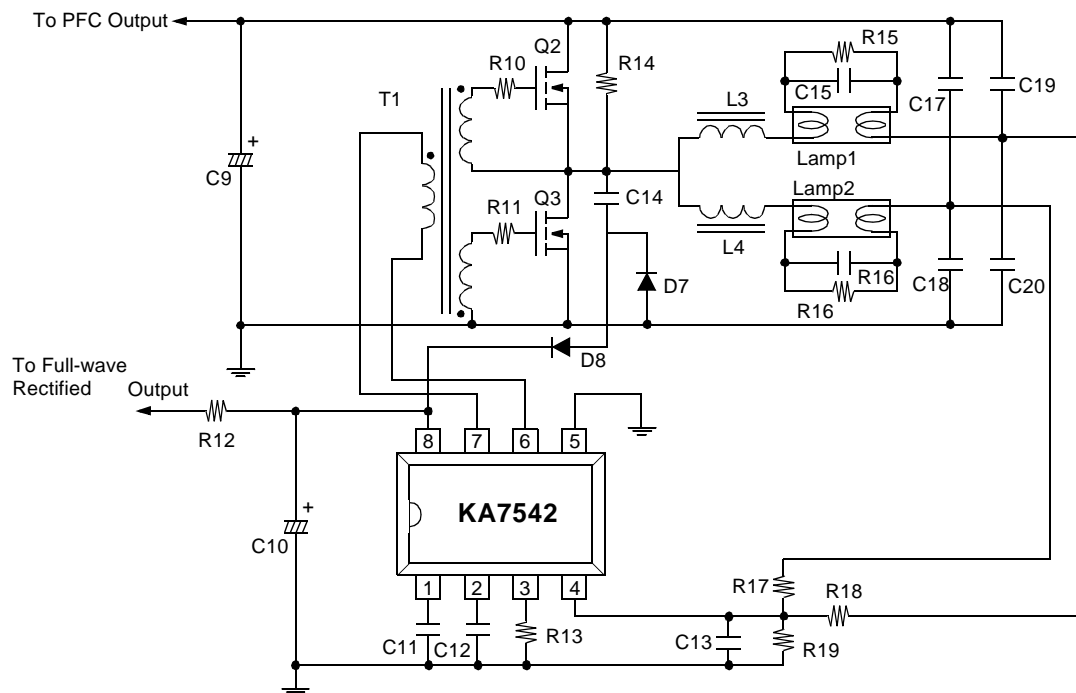
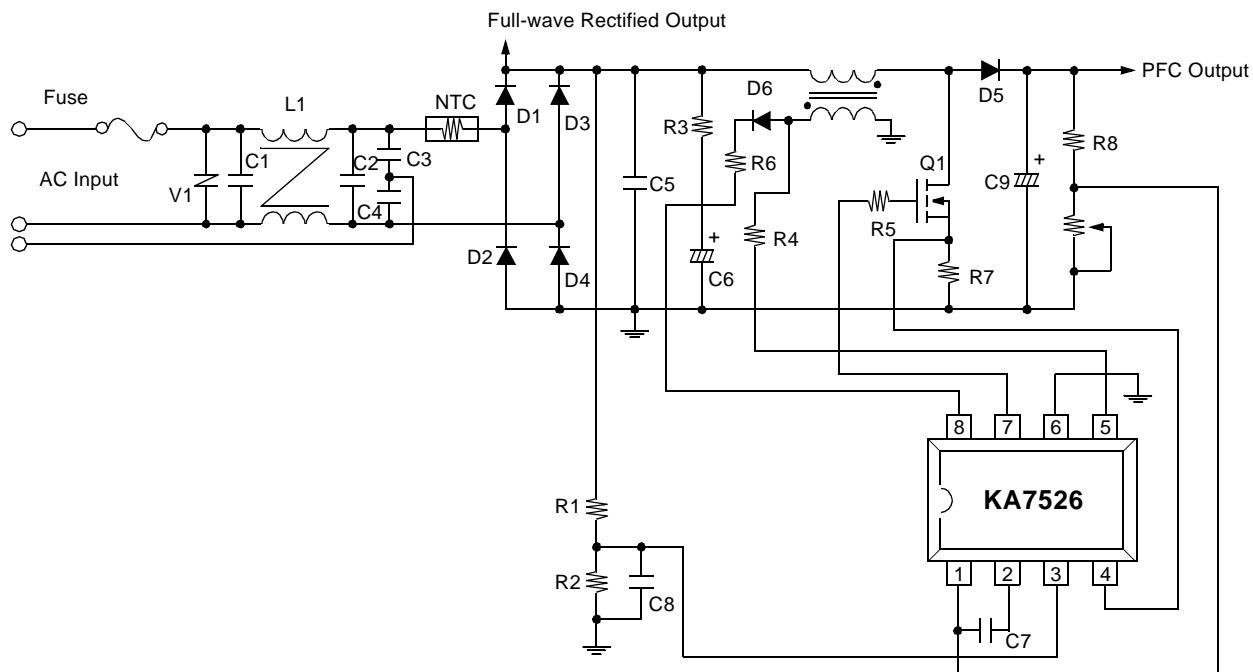

## COMPONENT LISTING (for Application Circuit #3)

Reference	Value	Part Number	Manufacturer
R1	2.2M $\Omega$ -F, 1/4W	26mm Type	ABCO
R2	11k $\Omega$ -F, 1/4W	26mm Type	ABCO
R3, 12	130k $\Omega$ , 1/2W	26mm Type	ABCO
R4	22k $\Omega$ -J, 1/4W	26mm Type	ABCO
R5, 10, 11	47 $\Omega$ -J, 1/4W	26mm Type	ABCO
R6	3.3 $\Omega$ , 1/4W	26mm Type	ABCO
R7	1 $\Omega$ -J, 1W	26mm Type	ABCO
R8	1M $\Omega$ -F, 1/4W	26mm Type	ABCO
R9	10k $\Omega$ Variable Resistor	-	ABCO
R13	20k $\Omega$ -F, 1/4W	26mm Type	ABCO
R14	180k $\Omega$ -J, 1/4W	26mm Type	ABCO
R15, 16	330k $\Omega$ -J, 1/4W	26mm Type	ABCO
R17, 18	680k $\Omega$ -J, 1/4W	26mm Type	ABCO
R19	8k $\Omega$ -J, 1/4W	26mm Type	ABCO
C1, 2	0.15 $\mu$ F, 630V	MEP-CAP	WOORYANG
C3, 4	2200pF, 3000V	Y-CAP	SAMSUNG
C5	0.1 $\mu$ F, 400V	MPE-CAP	WOORYANG
C6	22 $\mu$ F, 35V	Electrolytic	SAMSUNG
C7, C11	0.22 $\mu$ F, 25V	Ceramic	DONGIL
C8	0.01 $\mu$ F, 25V	Ceramic	DONGIL
C9	47 $\mu$ F, 450V	Electrolytic	SAMSUNG
C10	55 $\mu$ F, 35V	Electrolytic	SAMSUNG
C12	240pF, 25V	Ceramic	DONGIL
C13	0.1 $\mu$ F, 25V	Ceramic	DONGIL
C14	680pF, 630V	PPF-CAP	WOORYANG
C15, 16	6800pF, 1000V	PP-CAP	WOORYANG
C17, 18, 19, 20	6800pF, 630V	PPF-CAP	WOORYANG

## COMPONENT LISTING (for Application Circuit #3)

Reference	Value	Part Number	Manufacturer
D1, 2, 3, 4	1000V, 1A	IN4007GP	GI
D5	1000V, 1.5A	RGP15J	GI
D6, 7, 8	75V, 150mA	IN4148	ROHM
L1	-	BSF2125	NAMYANG
L2	450uF (62T:3.5T) 24AWG	EI2820	NAMYANG
L3, 4	3.1mH	EI2820	NAMYANG
T1	-	EE1619	NAMYANG
Fuse	-	52NM250V, 3A	SAMSUNG
V1	430V	INR140, 431	ILJIN
Q1, 2, 3	500V, 4.5A	IRF830	SAMSUNG

PACKAGE DIMENSION

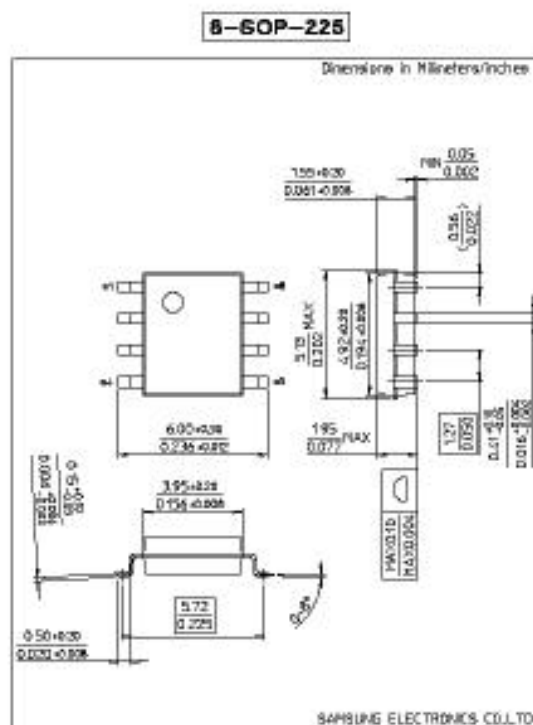
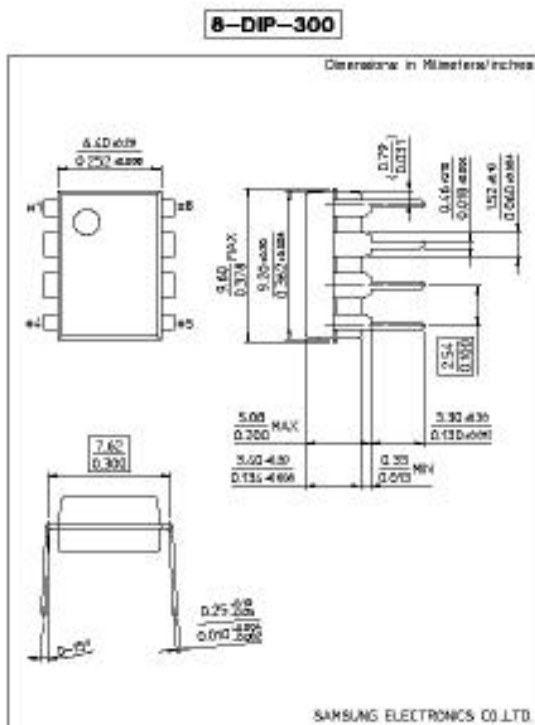

## TRADEMARKS

The following are registered and unregistered trademarks Fairchild Semiconductor owns or is authorized to use and is not intended to be an exhaustive list of all such trademarks.

ACEx™	ISOPLANAR™	UHC™
CoolFET™	MICROWIRE™	VCX™
CROSSVOLT™	POP™	
E <sup>2</sup> CMOS™	PowerTrench™	
FACT™	QST™	
FACT Quiet Series™	Quiet Series™	
FAST®	SuperSOT™-3	
FASTr™	SuperSOT™-6	
GTO™	SuperSOT™-8	
HiSeC™	TinyLogic™	

## DISCLAIMER

FAIRCHILD SEMICONDUCTOR RESERVES THE RIGHT TO MAKE CHANGES WITHOUT FURTHER NOTICE TO ANY PRODUCTS HEREIN TO IMPROVE RELIABILITY, FUNCTION OR DESIGN. FAIRCHILD DOES NOT ASSUME ANY LIABILITY ARISING OUT OF THE APPLICATION OR USE OF ANY PRODUCT OR CIRCUIT DESCRIBED HEREIN; NEITHER DOES IT CONVEY ANY LICENSE UNDER ITS PATENT RIGHTS, NOR THE RIGHTS OF OTHERS.

## LIFE SUPPORT POLICY

FAIRCHILD'S PRODUCTS ARE NOT AUTHORIZED FOR USE AS CRITICAL COMPONENTS IN LIFE SUPPORT DEVICES OR SYSTEMS WITHOUT THE EXPRESS WRITTEN APPROVAL OF FAIRCHILD SEMICONDUCTOR CORPORATION. As used herein:

1. Life support devices or systems are devices or systems which, (a) are intended for surgical implant into the body, or (b) support or sustain life, or (c) whose failure to perform when properly used in accordance with instructions for use provided in the labeling, can be reasonably expected to result in significant injury to the user.
2. A critical component is any component of a life support device or system whose failure to perform can be reasonably expected to cause the failure of the life support device or system, or to affect its safety or effectiveness.

## PRODUCT STATUS DEFINITIONS

### Definition of Terms

Datasheet Identification	Product Status	Definition
Advance Information	Formative or In Design	This datasheet contains the design specifications for product development. Specifications may change in any manner without notice.
Preliminary	First Production	This datasheet contains preliminary data, and supplementary data will be published at a later date. Fairchild Semiconductor reserves the right to make changes at any time without notice in order to improve design.
No Identification Needed	Full Production	This datasheet contains final specifications. Fairchild Semiconductor reserves the right to make changes at any time without notice in order to improve design.
Obsolete	Not In Production	This datasheet contains specifications on a product that has been discontinued by Fairchild semiconductor. The datasheet is printed for reference information only.