

DUAL PWM CONTROLLER

The KA7551 is a dual PWM control circuit designed for power supply control.

This PWM controller includes 2.5V regulator block, two error amplifier blocks, adjustable oscillator block, undervoltage lockout block and common emitter output transistor block. The error amplifier have a common mode voltage range of 1.05V to 1.45V and the dead time control can adjust the duty cycle 0 to 100%.

The oscillator may be operated 1KHz to 500KHz using by C_T and R_T control. During low V_{CC} conditions, the under voltage lockout control circuit can made the outputs off until the internal circuitry start on.

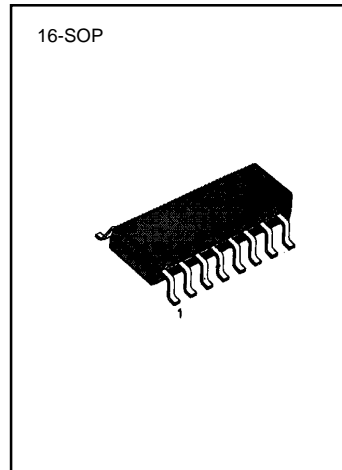

FEATURES

- Dual PWM control circuitry
- Oscillator frequency : 1KHz ~ 500KHz
- Internal under voltage lockout control
- Wide supply voltage range: 3.6V to 40V
- Internal reference voltage: 2.5V

ORDERING INFORMATION

Device	Package	Operating Temperature
KA7551	16 SOP	-25 ~ + 85°C

APPLICATIONS

- DC-DC converter
- Low Power Switching Mode Power Supply

BLOCK DIAGRAM

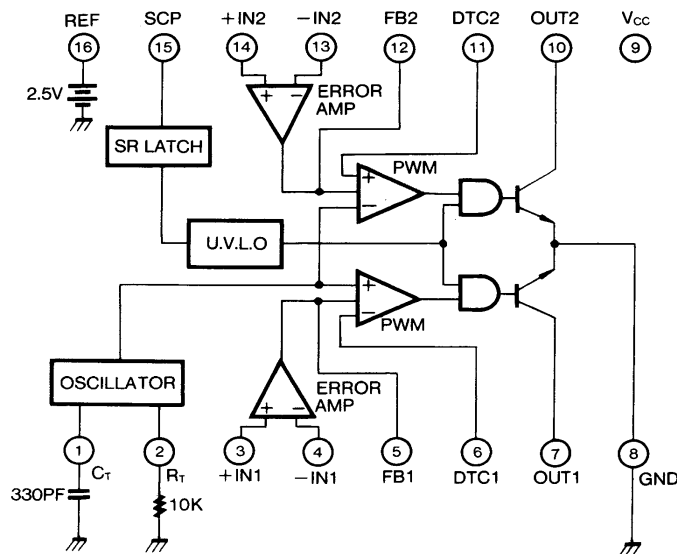

ABSOLUTE MAXIMUM RATINGS

Characteristic	Symbol	Value	Unit
Supply Voltage	V_{CC}	41	V
Collector Output Voltage	V_C	51	V
Collector Output Current	I_C	21	mA
Operating Temperature Range	T_{OPR}	- 25 ~ 85	°C
Amplifier Input Voltage	T_{ID}	20	V

ELECTRICAL CHARACTERISTICS

Characteristic	Symbol	Test Conditions	Min	Typ	Max	Unit
REFERENCE SECTION						
Output Voltage	V_R	$I_O = 1\text{mA}$	2.4	2.5	2.6	V
Input Regulation	ΔV_O	$V_S = 3.6 \sim 40\text{V}$	-	2.0	12.5	mV
Output Regulation	ΔV_O	$I_O = 0.1\text{mA} \sim 1\text{mA}$	-	1.0	7.5	mV
Short Circuit Current	I_S	$V_O = 0\text{V}$	3	10	30	mA
Output Voltage Change	$\Delta V(I)$	$T_A = -20 \text{ to } +25^\circ\text{C}$	- 1.0	- 0.1	1.0	%
With Temperature	$\Delta V(II)$	$T_A = +20 \text{ to } +85^\circ\text{C}$	- 1.0	- 0.2	1.0	
UNDER VOLTAGE LOCKOUT SECTION						
Upper Threshold Voltage (pin9)	$V_{TH(U)}$	$I_{REF} = 0.1\text{mA}$	-	2.72	-	V
Lower Threshold Voltage (pin9)	$V_{TH(L)}$	$I_{REF} = 0.1\text{mA}$	-	2.6	-	V
Hysteresis (pin9)	V_{HYS}	$I_{REF} = 0.1\text{mA}$	80	120	-	mV
Reset Threshold Voltage (pin9)	V_{RES}	$I_{REF} = 0.1\text{mA}$	1.5	1.8	-	V
PROTECTION CONTROL SECTION						
Input Threshold Voltage (pin 15)	$V_{TH(I)}$	$V_5 = V_{12} = 2.5\text{V}$	0.65	0.7	0.75	V
Standby Voltage (pin 15)	V_S	$V_5 = V_{12} = 2.5\text{V}$ NO PULL UP	140	185	230	mV
Latched Input Voltage (pin 15)	V_{LT}	$V_5 = V_{12} = 2.5\text{V}$ NO PULL UP	-	60	120	mV
Input Source Current	I_{SR}	$V_5 = V_{12} = 2.5\text{V}$ $V_I = 0.7\text{V}$	10	15	20	uA
Comparator Threshold Voltage (pin 5 and pin 12)	V_{CTH}		-	1.18	-	V

ELECTRICAL CHARACTERISTICS

Characteristic	Symbol	Test Conditions	Min	Typ	Max	Unit
ERROR AMPLIFIER SECTION						
Input Offset Voltage	V_{OS}	$V_O = 1.25V$	-	-	6.0	mV
Input Bias Current	I_B	$V_O = 1.25V$	-	160	500	nA
Input Offset Current	I_{OS}	$V_O = 1.25V$	-	-	100	nA
Common Mode Input Voltage Range	V_{CM}	$V_{CC} = 3.6V$ to 40V	1.05 ~ 1.5	-	-	V
Open Loop Voltage Amplification	A_V	$R_F = 200K\Omega$	70	80	-	dB
Unity Gain Bandwidth	G_{BW}		-	1.5	-	MHz
Common Mode Rejection Ration	CMRR		60	80	-	dB
Positive Output Voltage Swing	V_H		2.4	-	-	V
Negative Output Voltage Swing	V_L		-	-	1.0	V
Output Sink Current	I_{SK}	$V_{ID} = -0.1V, V_O = 1.25V$	0.5	1.6	-	mA
Output Source Current	I_{SR}	$V_{ID} = 0.1V, V_O = 1.25V$	45	70	-	uA
TOTAL DEVICE						
Standby Supply Current	I_{SS}	OFF-STATE	-	1.3	1.8	mA
Average Supply Current	I_{AS}	$R_T = 10K\Omega$	-	1.7	2.4	mA
OSCILLATOR SECTION						
Frequency	F	$C_T = 330pF, R_T = 10K\Omega$	-	200	-	KHz
Standard Deviation Of Frequency	ΔF	$C_T = 330pF, R_T = 10K\Omega$	-	10	-	%
Frequency Change With Voltage	ΔF_V	$V_S = 3.6$ to 40V	-	1.0	-	%
Frequency Change With Temperature	$\Delta F_{T(I)}$	$T_A = -20$ to +25 °C	-	-0.4	2.0	%
	$\Delta F_{T(II)}$	$T_A = +25$ to +85 °C	-	-0.2	2.0	%
DEAD TIME CONTROL SECTION						
Input Bias Current (pin6 and 11)	I_B		-	-	1.0	uA
Latch Mode(Source) Current (pin6 and 11)	I_{LM}		80	145	-	uA
Latch Input Voltage (pin6 and 11)	V_L	$I_O = 40uA$	2.3	-	-	V
Input Threshold Voltage	$V_{TH(I)}$	ZERO DUTY CYCLE	-	2.05	2.25	V
$A_T T = 10KHz$	$V_{TH(II)}$	MAX. DUTY CYCLE	1.2	1.45	-	V
OUTPUT SECTION						
Collector Off State Current	I_C	$V_O = 50V$	-	-	10uA	nA
Output Saturation Voltage	V_{SAT}	$I_O = 10mA$	-	1.2	2.0	V
Short Circuit Output Current	I_{SH}	$V_O = V_{CC}$	-	90	-	mA

TRADEMARKS

The following are registered and unregistered trademarks Fairchild Semiconductor owns or is authorized to use and is not intended to be an exhaustive list of all such trademarks.

ACEx™	ISOPLANAR™	UHC™
CoolFET™	MICROWIRE™	VCX™
CROSSVOLT™	POP™	
E ² CMOS™	PowerTrench™	
FACT™	QST™	
FACT Quiet Series™	Quiet Series™	
FAST®	SuperSOT™-3	
FASTr™	SuperSOT™-6	
GTO™	SuperSOT™-8	
HiSeC™	TinyLogic™	

DISCLAIMER

FAIRCHILD SEMICONDUCTOR RESERVES THE RIGHT TO MAKE CHANGES WITHOUT FURTHER NOTICE TO ANY PRODUCTS HEREIN TO IMPROVE RELIABILITY, FUNCTION OR DESIGN. FAIRCHILD DOES NOT ASSUME ANY LIABILITY ARISING OUT OF THE APPLICATION OR USE OF ANY PRODUCT OR CIRCUIT DESCRIBED HEREIN; NEITHER DOES IT CONVEY ANY LICENSE UNDER ITS PATENT RIGHTS, NOR THE RIGHTS OF OTHERS.

LIFE SUPPORT POLICY

FAIRCHILD'S PRODUCTS ARE NOT AUTHORIZED FOR USE AS CRITICAL COMPONENTS IN LIFE SUPPORT DEVICES OR SYSTEMS WITHOUT THE EXPRESS WRITTEN APPROVAL OF FAIRCHILD SEMICONDUCTOR CORPORATION. As used herein:

1. Life support devices or systems are devices or systems which, (a) are intended for surgical implant into the body, or (b) support or sustain life, or (c) whose failure to perform when properly used in accordance with instructions for use provided in the labeling, can be reasonably expected to result in significant injury to the user.
2. A critical component is any component of a life support device or system whose failure to perform can be reasonably expected to cause the failure of the life support device or system, or to affect its safety or effectiveness.

PRODUCT STATUS DEFINITIONS

Definition of Terms

Datasheet Identification	Product Status	Definition
Advance Information	Formative or In Design	This datasheet contains the design specifications for product development. Specifications may change in any manner without notice.
Preliminary	First Production	This datasheet contains preliminary data, and supplementary data will be published at a later date. Fairchild Semiconductor reserves the right to make changes at any time without notice in order to improve design.
No Identification Needed	Full Production	This datasheet contains final specifications. Fairchild Semiconductor reserves the right to make changes at any time without notice in order to improve design.
Obsolete	Not In Production	This datasheet contains specifications on a product that has been discontinued by Fairchild semiconductor. The datasheet is printed for reference information only.