

2-PHASE DRUM MOTOR DRIVER

The KA8328D is a monolithic integrated circuit, and it is suitable for drum motor driver of VCR system.

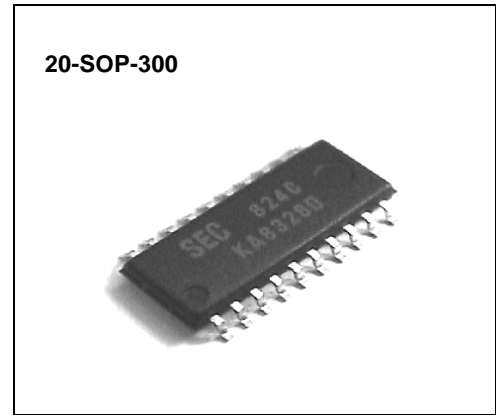

FEATURES

- 2-phase, full-wave, linear BLDC motor driver with 2 hall sensors
- Built-in voltage or current control circuit.
- Built-in regulated power supply for hall devices.
- Built-in thermal shutdown (TSD) circuit.
- Built-in hall amp.
- High output current

ORDERING INFORMATION

Device	Package	Operating Temperature
KA8328D	20-SOP-300	-25°C ~ +75°C

TARGET APPLICATIONS

- VCR drum motors

BLOCK DIAGRAM

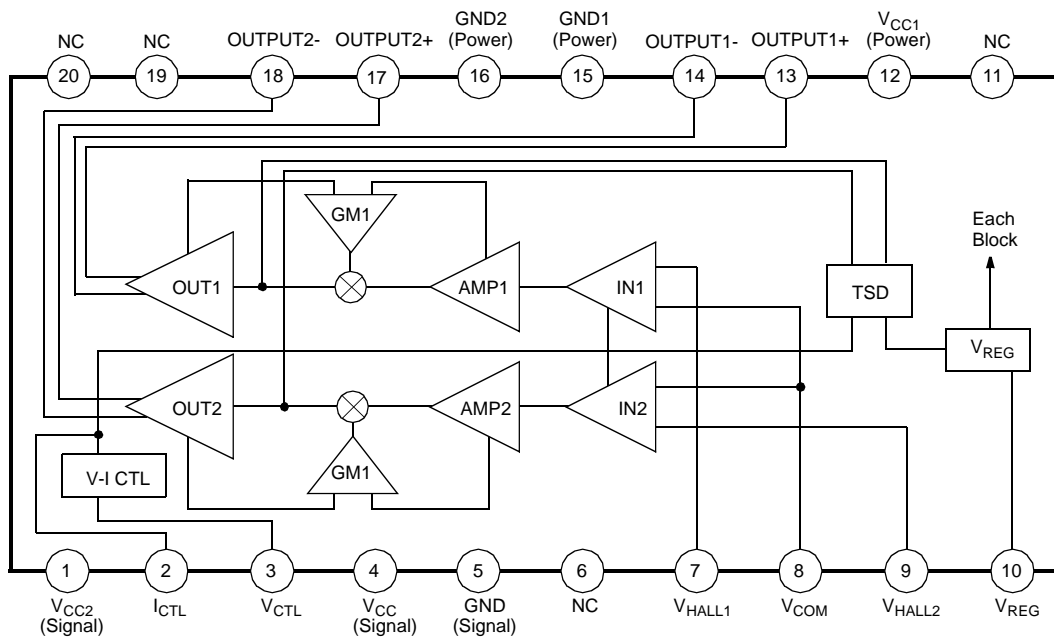

PIN CONFIGURATIONS

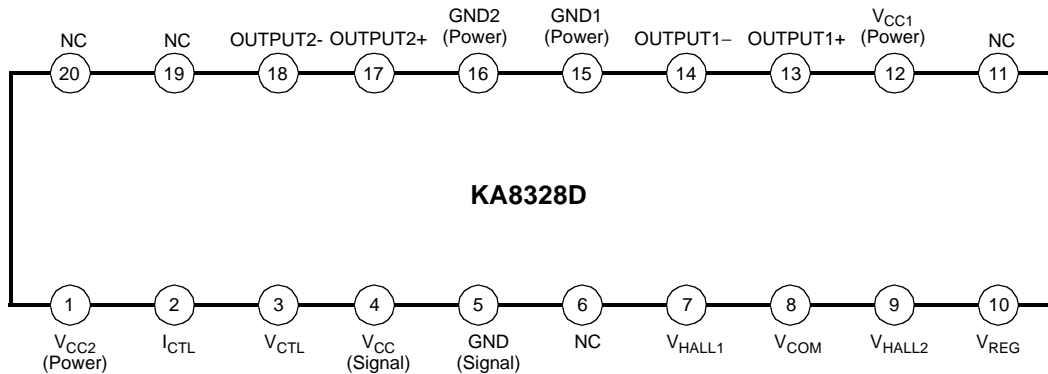

PIN DESCRIPTION

Pin No.	Symbol	I/O	Description	Pin No.	Symbol	I/O	Description
1	V _{CC2}	–	Supply voltage (Power)	11	NC	–	No connection
2	I _{CTL}	I	Current control input	12	V _{CC1}	–	Supply voltage (Power)
3	V _{CTL}	I	Voltage control input	13	OUTPUT +	O	Φ A+ output
4	V _{CC}	–	Supply voltage (Signal)	14	OUTPUT –	O	Φ A– output
5	GND	–	Ground (Signal)	15	GND1	–	Ground (Power)
6	NC	–	No connection	16	GND2	–	Ground (Power)
7	V _{HALL1}	I	Hall signal input	17	OUTPUT +	O	Φ B+ output
8	V _{COM}	I	Common hall signal input	18	OUTPUT –	O	Φ B– output
9	V _{HALL2}	I	Hall signal input	19	NC	–	No connection
10	V _{REG}	O	Regulated voltage output	20	NC	–	No connection

EQUIVALENT CIRCUITS

Description	Pin No.	Internal circuit
Driver input (Current control)	2	
Driver input (Voltage control)	3	
Hall signal input	7,8,9	
Regulator output	10	
Driver output	13,14 17,18	

ABSOLUTE MAXIMUM RATING (Ta=25°C)

Characteristics	Symbol	Value	Unit	Remark
Supply voltage	V_{CCmax}	20	V	–
Maxium Output current	I_{Omax}	1.2 ^{note1}	A	–
V_{REG} output current	I_{REGmax}	40	mA	–
I_{CTL} input current	I_{CTLmax}	1	mA	
V_{COM} input voltage	V_{COMmax}	$V_{REG}-1$	V	
Power dissipation	P_d	1 ^{note2}	W	No heat sink
Operating temperature	T_{OPR}	-25 ~ +75	°C	Ambient temperature
Storage temperature	T_{STG}	-40 ~ +125	°C	Ambient temperature

NOTES:

- Duty 1/100, pulse width 500 μ s
- When mounted on glass epoxy PCB (76.2 × 114 × 1.57mm)
 - Power dissipation reduces 120mW / °C for using above Ta=25°C
 - Do not exceed Pd and SOA.

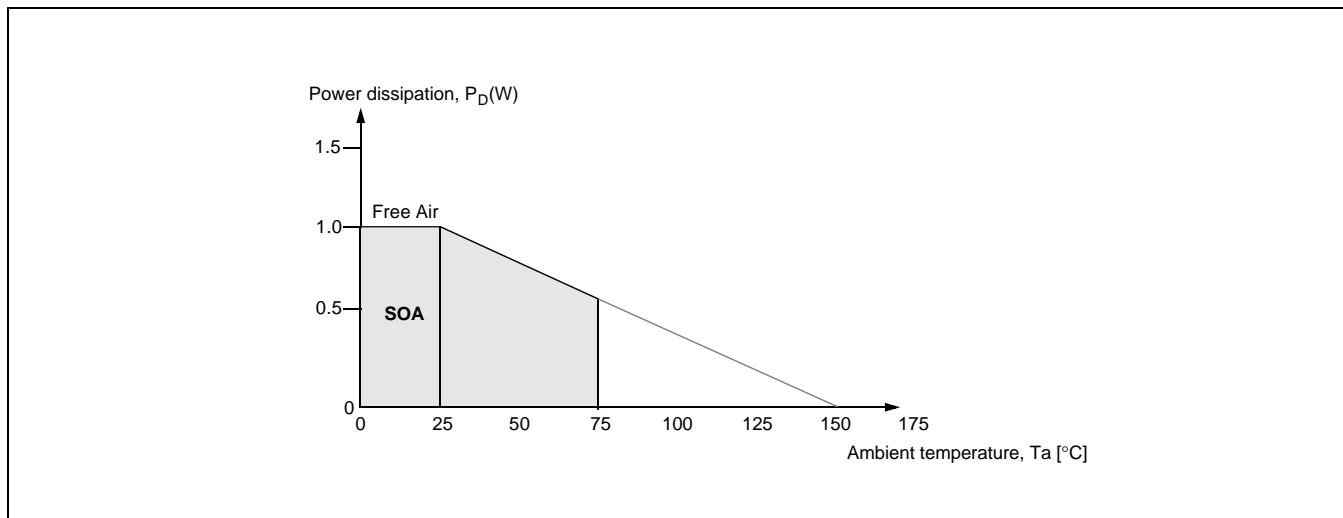
PD GRAPH**OPERATING CONDITION**

Characteristics	Symbol	Value	Unit
Operating supply voltage	V_{CC}	8 ~ 16	V

ELECTRICAL CHARACTERISTICS

(Ta=25°C, V_{CC}=14V, unless otherwise specified)

Characteristic	Symbol	Test conditions	Spec.			Unit
			Min.	Typ.	max.	
Quiescent current	I _Q	V _{CC} =14V	–	6	10	mA
Regulated voltage (2)	V _{REG2}	V _{CC} =14V	4.6	5.0	5.4	V
Regulated voltage (5)	V _{REG5}	V _{CC} =14V, I _{REG} =20mA	4.6	5.0	5.4	V
Regulated voltage (8)	V _{REG8}	V _{CC} =14V, I _{REG} =40mA	4.6	5.0	5.4	V
I _{CTL} input voltage	V _{ICTL}	V _{CC} =14V, I _{REG} =10mA	1.2	1.3	1.4	V
Current gain G _A	G _{A2}	V _{HALL1} =2.5V, V _{COM} =2.2V I _{CTL} =100µA	4100	4900	5700	–
Current gain G _B	G _{B2}	V _{HALL1} =2.5V, V _{COM} =2.2V I _{CTL} =100µA	4100	4900	5700	–
Current gain ratio	R	G _{A2} / G _{B2}	0.8	1	1.2	–
Output transistor saturation voltage (Upper)	V _{S-UA3}	I _O =800mA	–	1.3	2.0	V
Output transistor saturation voltage (Lower)	V _{S-DA3}	I _O =800mA	–	2.0	3.0	V
Motor drive A	I _{O-A1}	V _{HALL1} =2.5V, V _{COM} =2.2V I _{CTL} =100µA	720	850	980	mA
Motor drive B	I _{O-B1}	V _{HALL1} =2.5V, V _{COM} =2.2V I _{CTL} =100µA	720	850	980	mA
VOLTAGE CONTROL						
V _{CTL} offset voltage	V _{OFFL}	V _{CTL} =0~V _{REG}	–200	0	200	mV
V _{CTL} input current	I _{VCTL}	V _{CTL} =2.5V	–	1.0	6.0	µA
Voltage control gain	G _M	ΔI _O / ΔV _{CTL} V _{CTL} =V _{REF(2.3)} +0.5V V _{REF(2.3)} +1.0V V _{HALL1} =2.5V, V _{COM} =2.2V	0.38	0.51	0.70	A / V

NOTE: Graph. of voltage control gain

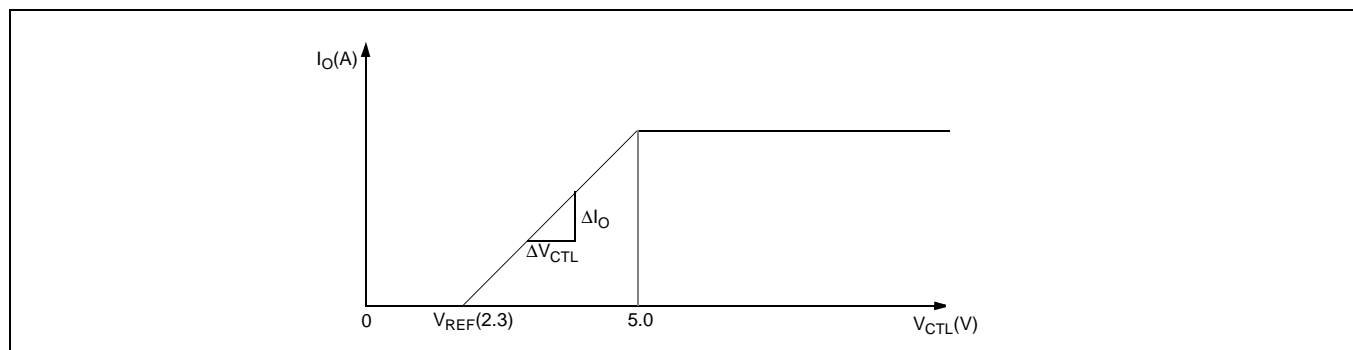

APPLICATION INFORMATION

1. The whole system concept of the KA8328D can be briefly diagrammatized as follows. Namely it may be thought to be an amplifier whose on-off action is operated in accordance with the output signals of the hall sensors which detects the rotor position. The servo current (I_{CTL}) inputted in the input terminal controls the output current (I_O) of the output terminal and the motor speed. At is the gain of the whole system, and determines the characteristic of the output to the input as in the following diagram.

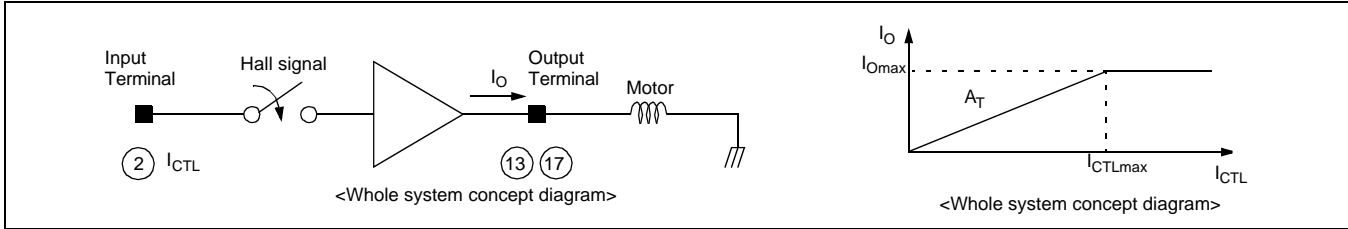

2. Also the output current (I_O) can be controlled through inputting the servo voltage (V_{CTL}) instead of the servo current (I_{CTL}) which applied to the input terminal. In this case, by using the V-I converter as in the following diagram, the servo voltage (V_{CTL}) is converted in turn into a current (I_{VO}) to control the output current (I_O).

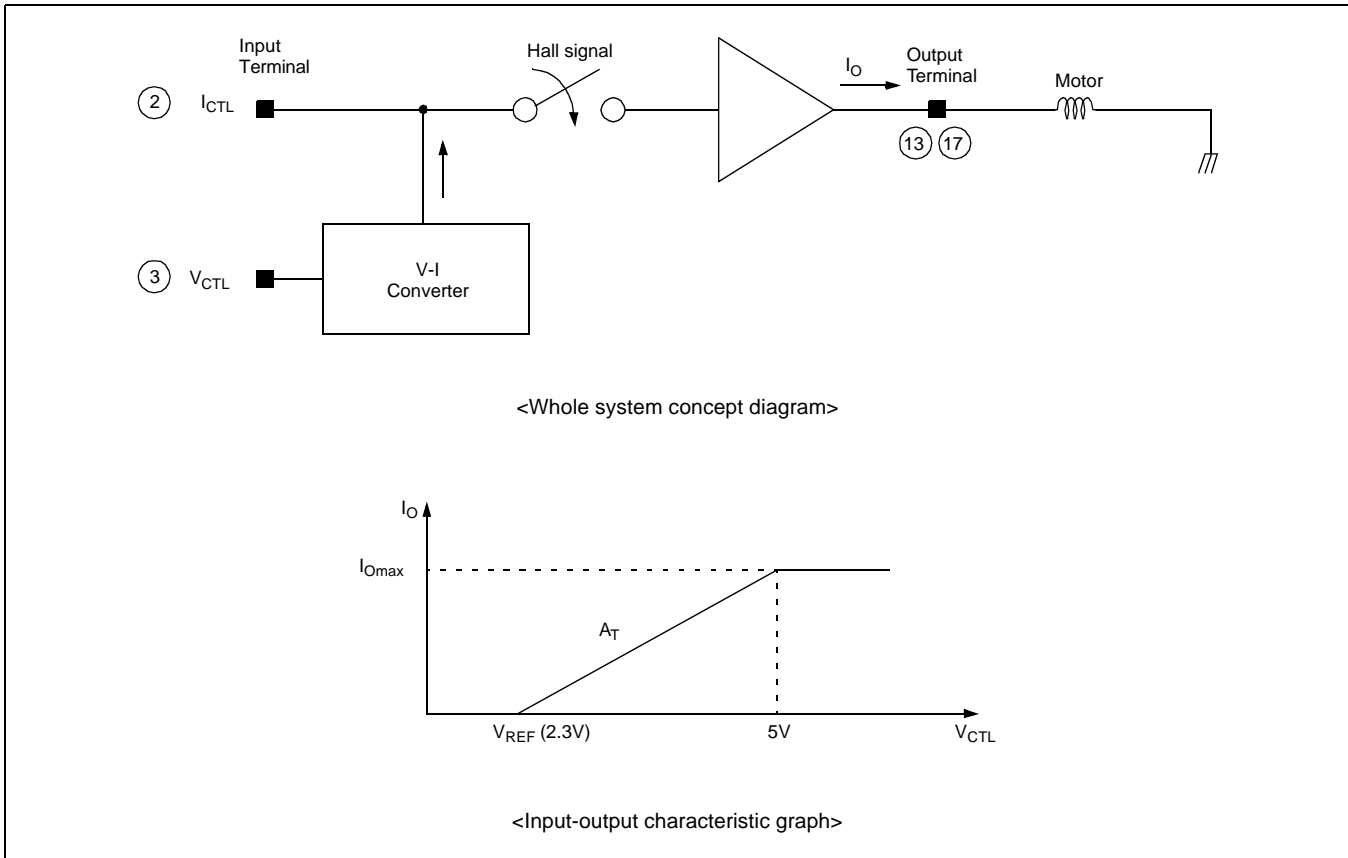

3.The whole system concept explained above can be expressed in a more detailed block diagram as follows.

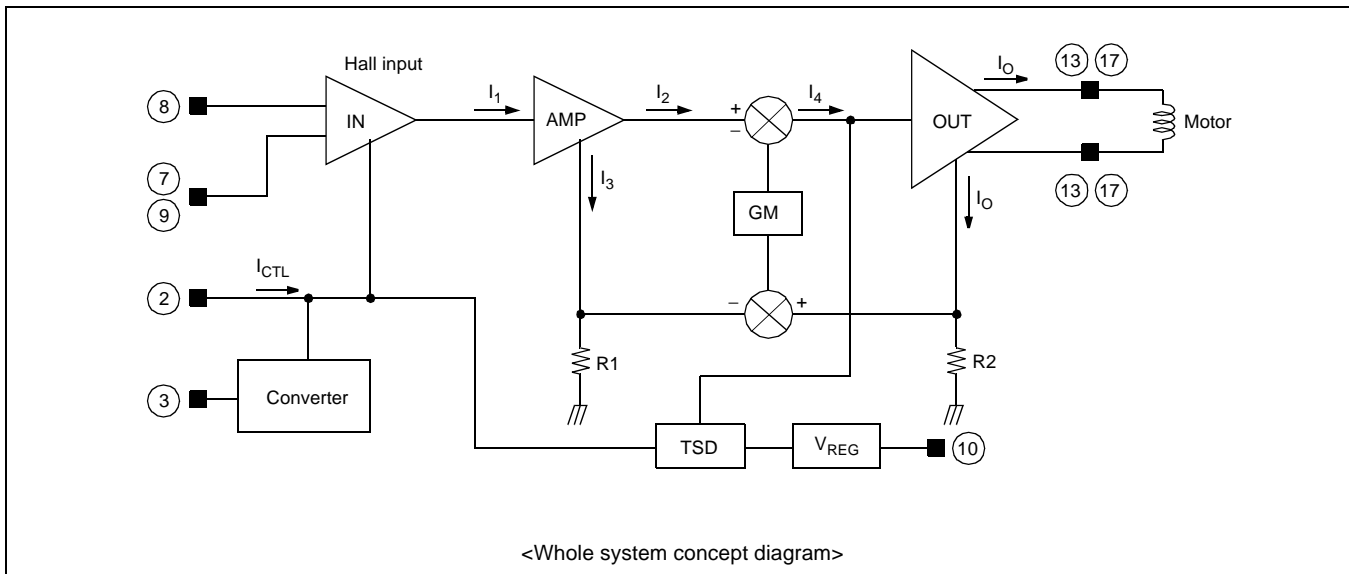

AMP, GM (Feedback), and OUT (Driver) are blocks which determine, the gain (A_T). The hall input functions as an ON-OFF switch which is driven by the hall signal. Amp is an amplifier which amplifies the input current 4 times. GM is a feedback circuit which returns the feedback of the output current (I_O), and OUT (Driver) is the power switch part which drives the motor.

V_{REG} is a constant voltage source which supply stabilized voltage to each block.

TSD is the overheat protective circuit which protect IC from the overheat, that is, in the event of overheat it protect IC through grounding the input part and OUT (Driver) part.

As for the input-output characteristic, if the input current $I_{CTL}=100\mu A$ is applied, then $I_1=100\mu A \rightarrow I_2 - I_3 = 400\mu A (=100\mu A \times 4) \rightarrow I_O=490mA$, so the current gain become 4900 times.

The output current is detected through the output current detecting resistance (R_2), and transferred to the feedback circuit (GM), and then again returned to OUT (Driver) as feedback, so the output current is kept constant at a desired value.

As a result the motor speed is also kept constant.

4. With having the output signal of the hall sensor which detects the rotor position and the servo current (or voltage) which controls the output current as in the following diagram, the differential amplifiers in the hall input parts are operated so that the current may flow at a proper phase of the motor.

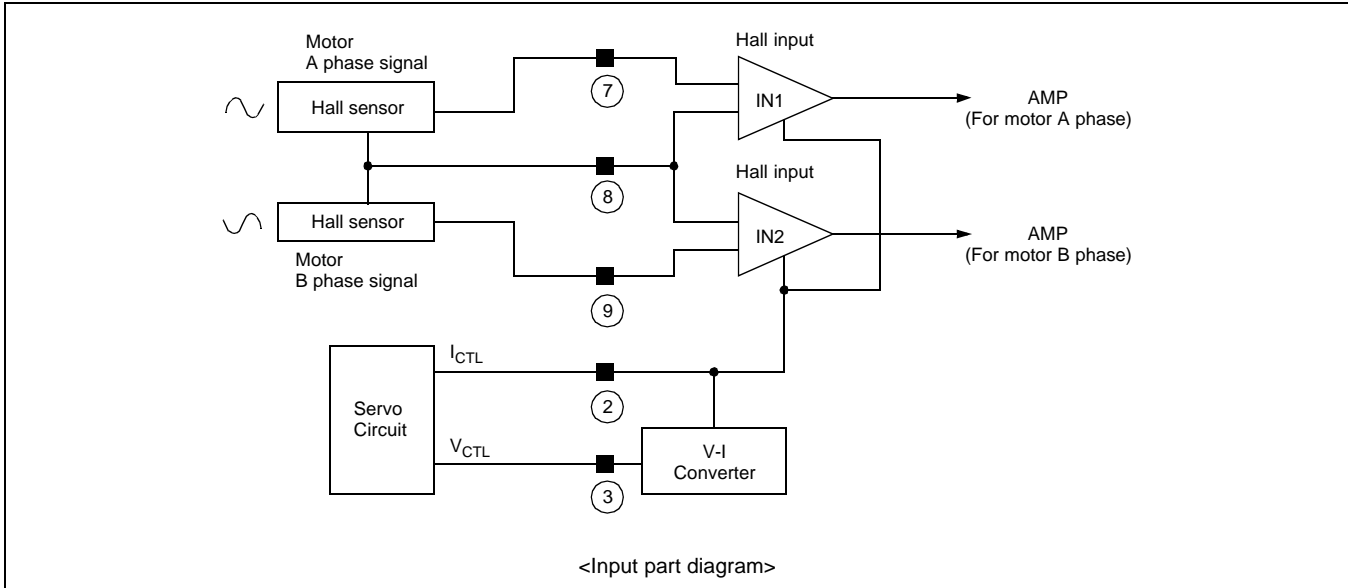

The followings is the simplified circuit diagram of the input part circuit. Firstly when the input control current (I_{CTL}) is inputted, TR Q5 is operated, and TR Q3 or TR Q4 of the differential amplifier is operated in accordance with the output signal of the Hall sensor, and so the current (I_1) is outputted.

Next when the input control voltage (V_{CTL}) is inputted, if the input voltage is higher than the standard voltage (V_{REF} , 2.3V), TR Q1 is operated, and so TR Q5 is operated by the current source (I_S).

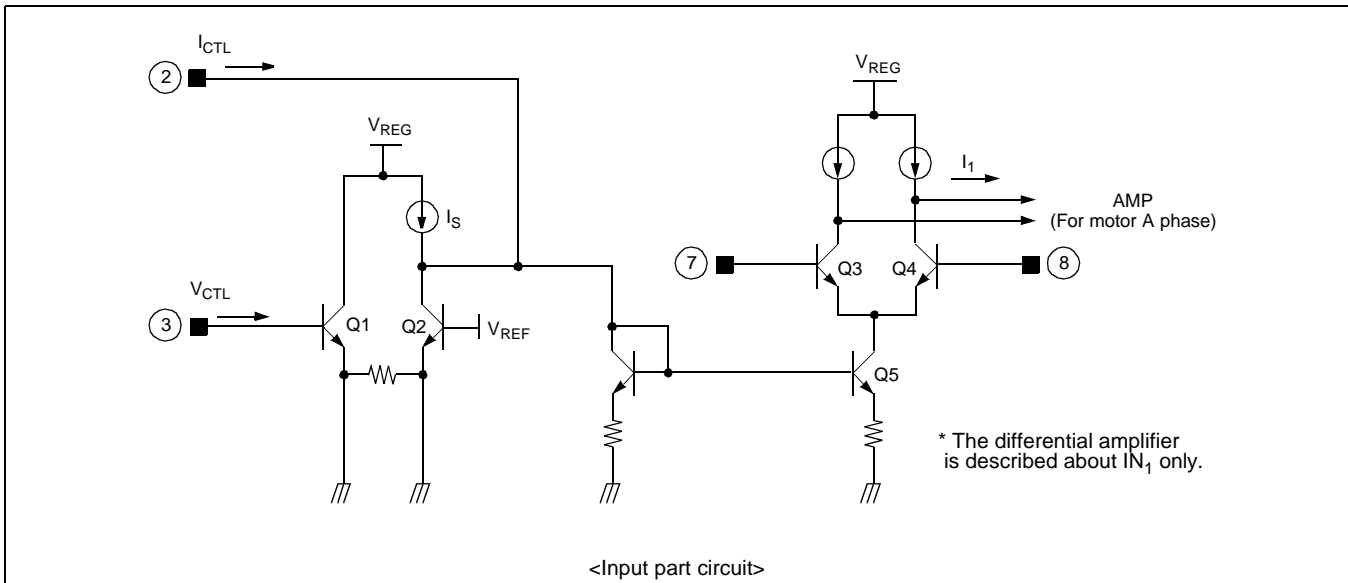

5. The constant voltage source (V_{REG}) has the function of keeping the output voltage always constant, with having the V_{CC} voltage as its input, as in the following diagram. V_{REG} always keeps constant voltage even though the V_{CC} or internal temperature changes because the band-gap referenced biasing circuit is used as the reference voltage source of the constant voltage source. V_{REG} becomes the supply voltage source of each internal block and the external hall sensors.

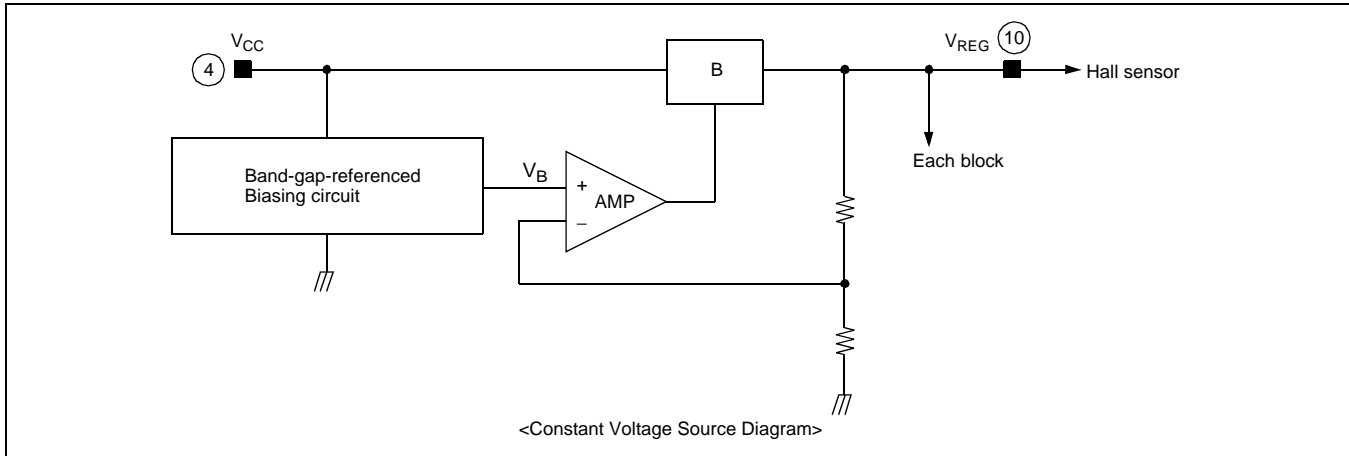

The following is the simplified circuit of the constant voltage source (V_{REG}). The output voltage (V_B) of the band-gap reference biasing circuit is the reference voltage, and always maintains constant voltage.

The other input voltage (V_R) changes according to the state of the output voltage. So the output voltage always maintains constant voltage with the voltage difference of the input voltage V_B and V_R .

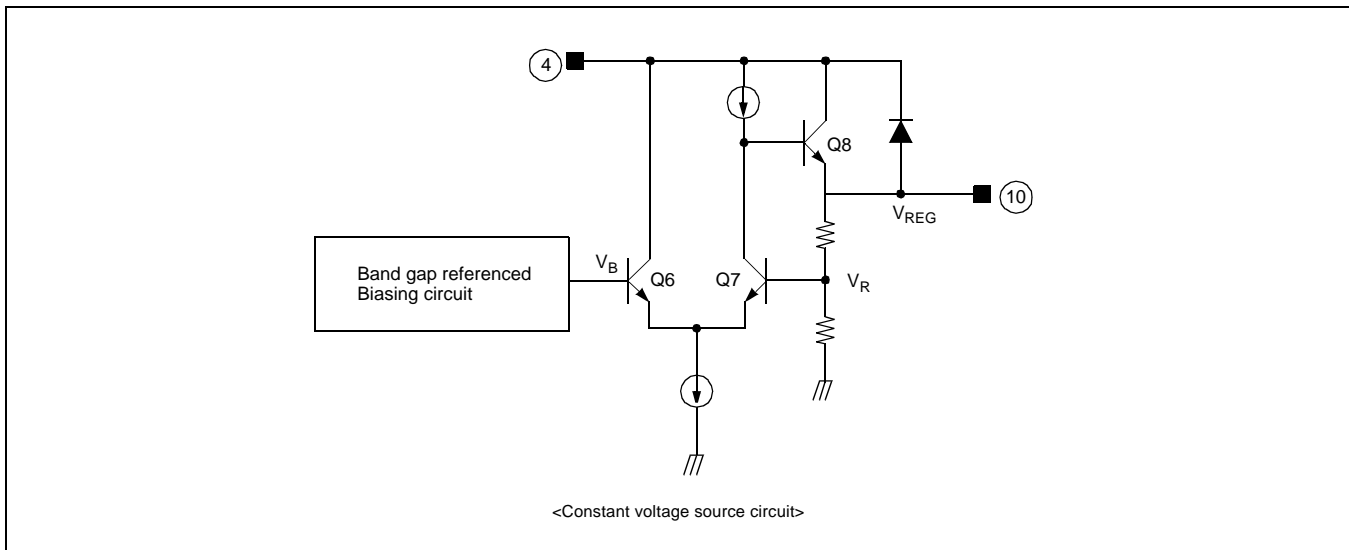

6.OUT (Driver) has the function of driving the motor through amplifying the driving current to a proper level.

Freewheeling diode is designed at the C-E terminal of each TR, and protect the TR by making the motor current freewheeling when the TR is turned off.

The motor current is kept constant through being detected by the resistance (R3) and returned as feedback again via the Feedback circuit. Accordingly the motor rotative velocity is also kept constant.

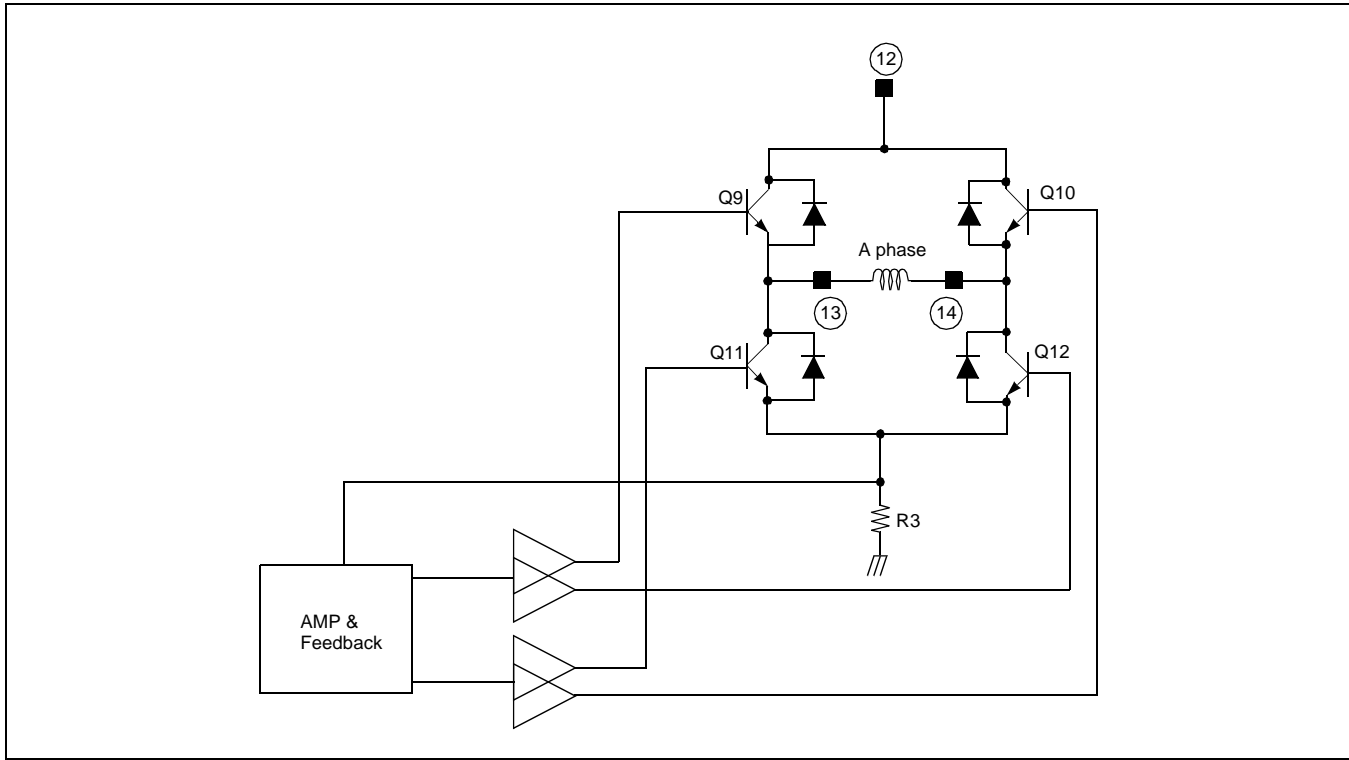

CHARACTERISTIC GRAPHS

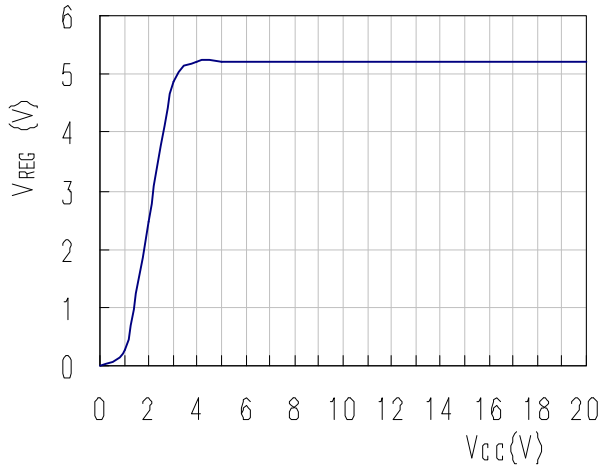

1. V_{CC} vs V_{REG}

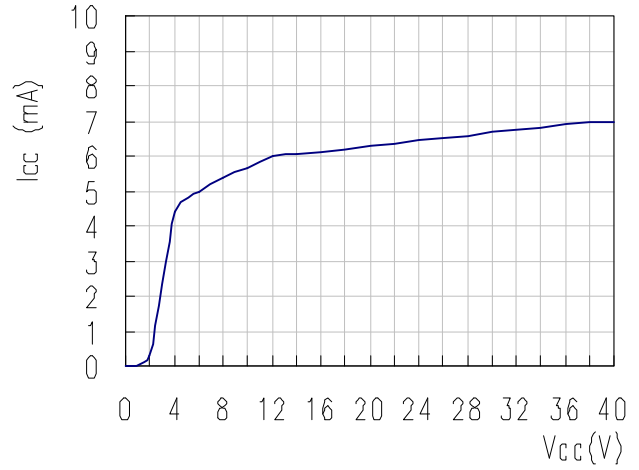

2. V_{CC} vs I_{CC}

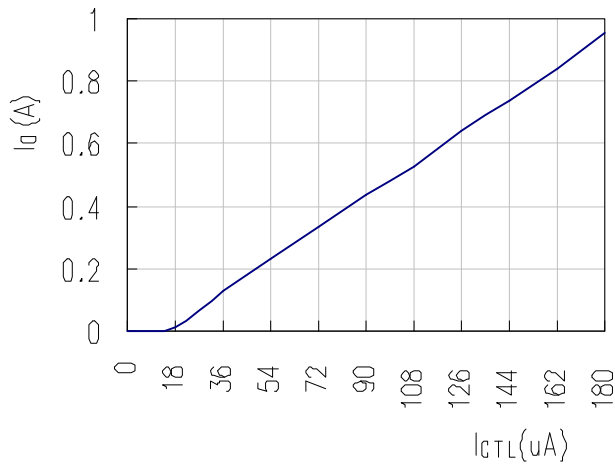

3. I_{CTL} vs I_O

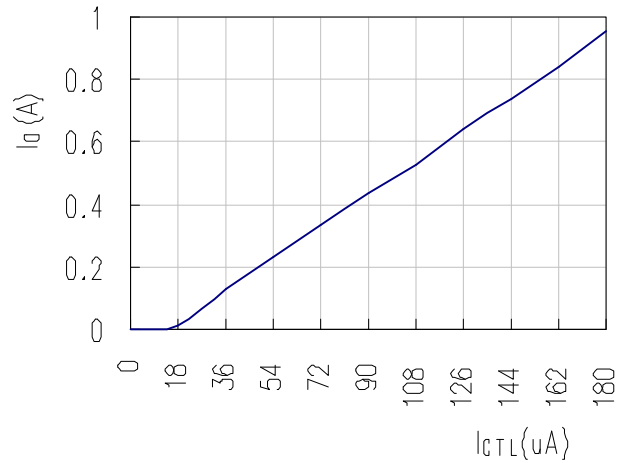

1. I_{CTL} vs V_{CTL}

TEST CIRCUIT

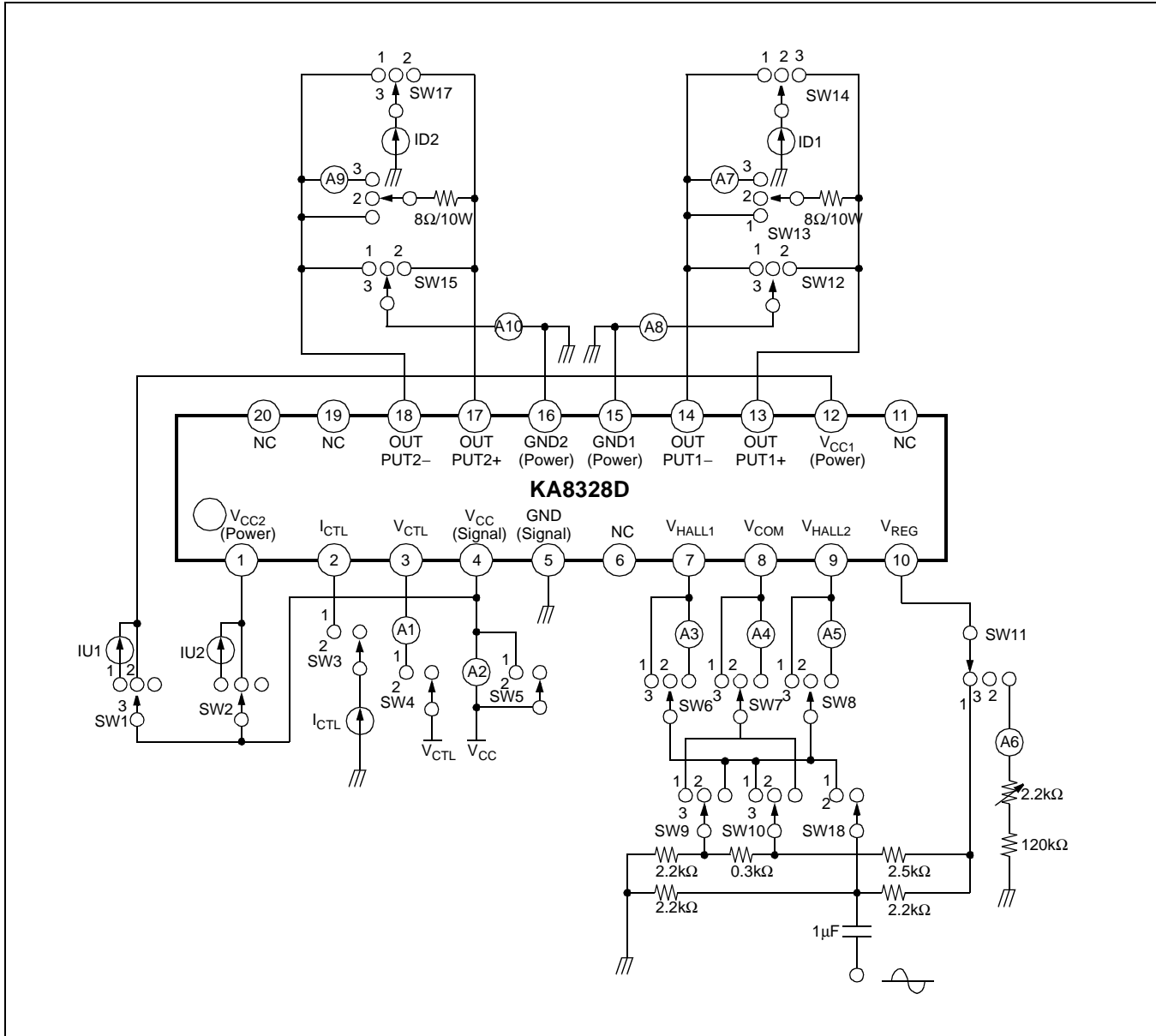

OUTPUT WAVEFORMS

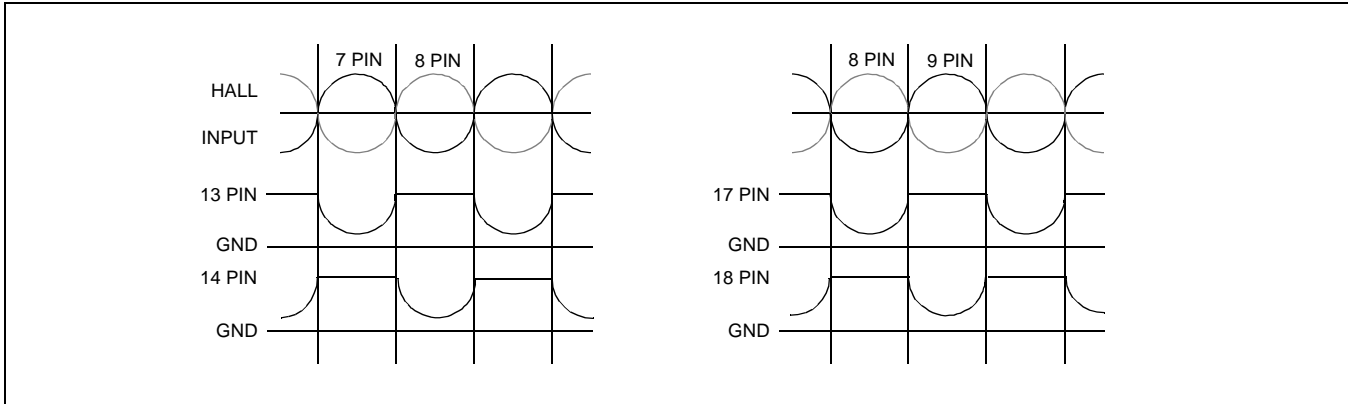

APPLICATION CIRCUIT

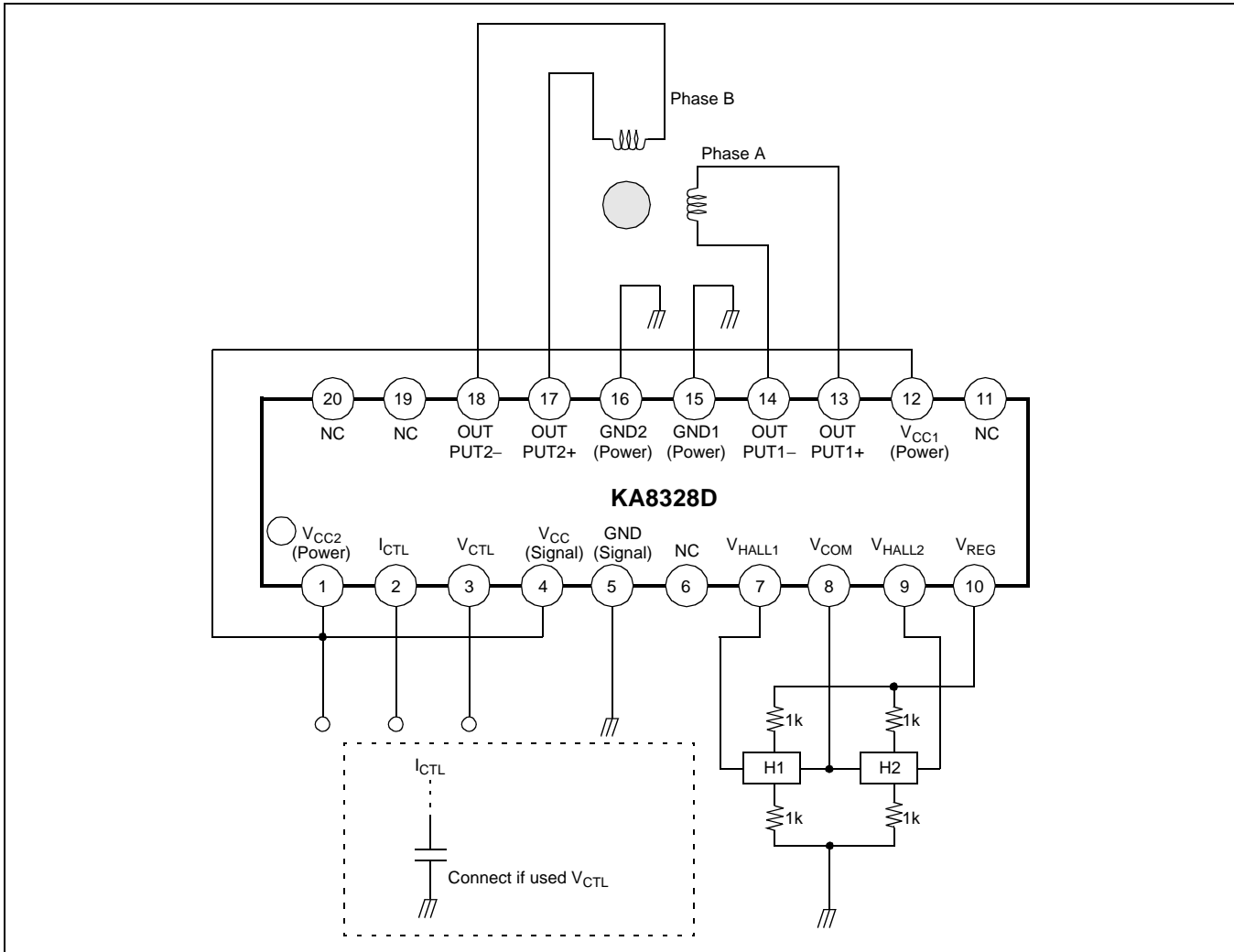

NOTES

TRADEMARKS

The following are registered and unregistered trademarks Fairchild Semiconductor owns or is authorized to use and is not intended to be an exhaustive list of all such trademarks.

ACEx™	ISOPLANAR™
CoolFET™	MICROWIRE™
CROSSVOLT™	POP™
E ² CMOS™	PowerTrench™
FACT™	QS™
FACT Quiet Series™	Quiet Series™
FAST®	SuperSOT™-3
FASTr™	SuperSOT™-6
GTO™	SuperSOT™-8
HiSeC™	TinyLogic™

DISCLAIMER

FAIRCHILD SEMICONDUCTOR RESERVES THE RIGHT TO MAKE CHANGES WITHOUT FURTHER NOTICE TO ANY PRODUCTS HEREIN TO IMPROVE RELIABILITY, FUNCTION OR DESIGN. FAIRCHILD DOES NOT ASSUME ANY LIABILITY ARISING OUT OF THE APPLICATION OR USE OF ANY PRODUCT OR CIRCUIT DESCRIBED HEREIN; NEITHER DOES IT CONVEY ANY LICENSE UNDER ITS PATENT RIGHTS, NOR THE RIGHTS OF OTHERS.

LIFE SUPPORT POLICY

FAIRCHILD'S PRODUCTS ARE NOT AUTHORIZED FOR USE AS CRITICAL COMPONENTS IN LIFE SUPPORT DEVICES OR SYSTEMS WITHOUT THE EXPRESS WRITTEN APPROVAL OF FAIRCHILD SEMICONDUCTOR CORPORATION. As used herein:

1. Life support devices or systems are devices or systems which, (a) are intended for surgical implant into the body, or (b) support or sustain life, or (c) whose failure to perform when properly used in accordance with instructions for use provided in the labeling, can be reasonably expected to result in significant injury to the user.
2. A critical component is any component of a life support device or system whose failure to perform can be reasonably expected to cause the failure of the life support device or system, or to affect its safety or effectiveness.

PRODUCT STATUS DEFINITIONS

Definition of Terms

Datasheet Identification	Product Status	Definition
Advance Information	Formative or In Design	This datasheet contains the design specifications for product development. Specifications may change in any manner without notice.
Preliminary	First Production	This datasheet contains preliminary data, and supplementary data will be published at a later date. Fairchild Semiconductor reserves the right to make changes at any time without notice in order to improve design.
No Identification Needed	Full Production	This datasheet contains final specifications. Fairchild Semiconductor reserves the right to make changes at any time without notice in order to improve design.
Obsolete	Not In Production	This datasheet contains specifications on a product that has been discontinued by Fairchild semiconductor. The datasheet is printed for reference information only.