

SINGLE DRIVER

KID65501P/F COMMON EMITTER.
 KID65502P/F COMMON EMITTER.
 KID65503P/F COMMON EMITTER.
 KID65504P/F COMMON EMITTER.
 KID65505P/F COMMON COLLECTOR.
 KID65506P/F COMMON COLLECTOR.
 KID65507P/F ISOLATED.

FEATURES

- Output Current : 200mA Max.
- High Voltage Outputs : 35V
- Input Compatible with Various Types of Logic
 - KID65501P/F
 - KID65505P/F } Using external resistor : General Purpose
 - KID65507P/F
 - KID65502P/F $R_{IN}=7V$ Zener Diode+10.5k Ω : 14~25V P-MOS
 - KID65503P/F
 - KID65506P/F } $R_{IN}=2.7k\Omega$: TTL, 5V C-MOS
 - KID65504P/F } $R_{IN}=10.5k\Omega$: 6~15V P-MOS, C-MOS

DESCRIPTION:

The KID65501P/F Series are comprised of seven or five NPN Transistor Arrays.
 For proper operation, the substrate (SUB) must be connected to the most negative voltage.

MAXIMUM RATINGS (Ta=25°C, unless otherwise noted)

CHARACTERISTIC	SYMBOL	RATING	UNIT
Collector-Emitter Voltage	V_{CEO}	35	V
Collector-Base Voltage	V_{CBO}	50	V
Collector Current	I_C	200	mA
Input Voltage	V_{IN}^*	-0.5 ~ +45	V
	V_{IN}^{**}	-0.5 ~ +30	
Input Current	I_{IN}^{***}	25	mA
Isolation Voltage	V_{SUB}	35	V
GND Terminal Current	I_{GND}	500	mA
Power Dissipation	P_D	1.0	W
		0.54	
Operating Temperature	T_{OPR}	-30 ~ 75	°C
Storage Temperature	T_{STG}	-55 ~ 150	°C

* KID65506P/F
 ** KID65502P/F, KID65503P/F, KID65504P/F
 *** KID65501P/F, KID65505P/F, KID65507P/F

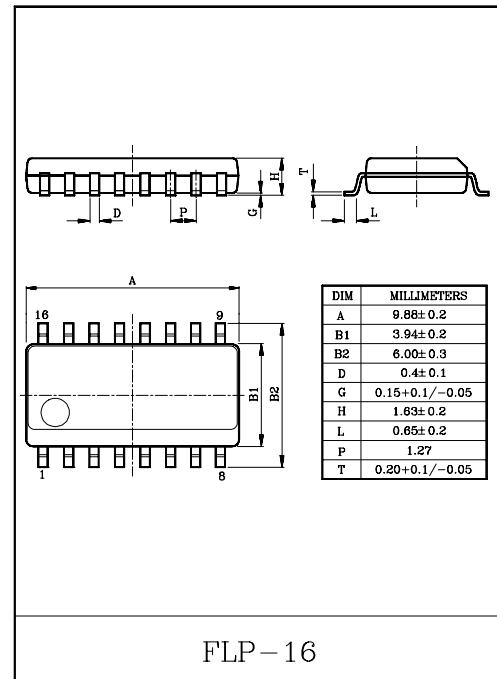
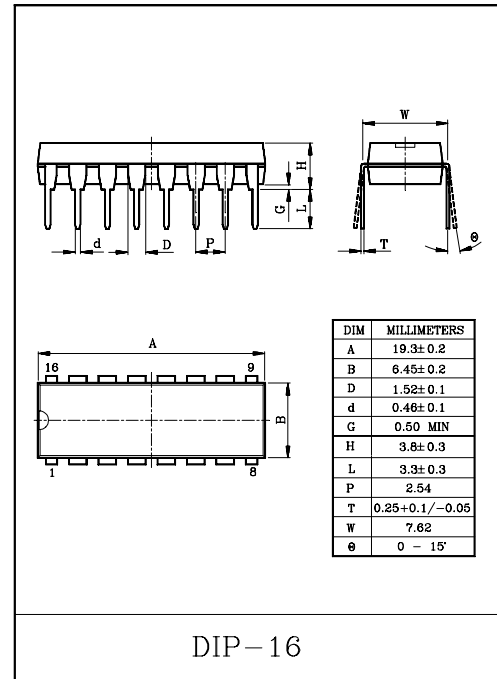

KID65501P/F ~ KID65507P/F

PIN CONNECTIONS (TOP VIEW)

KID65501P/F ,KID65502P/F, KIP65503P/F,
KID65504P/F

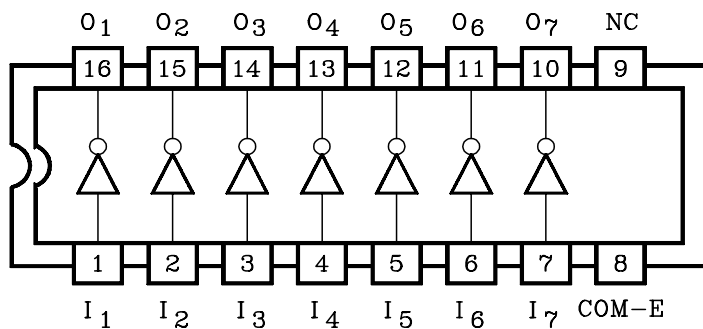

KID65505P/F, KID65506P/F

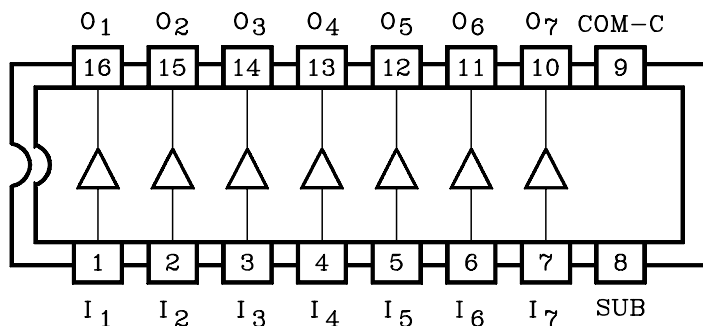

KID65507P/F

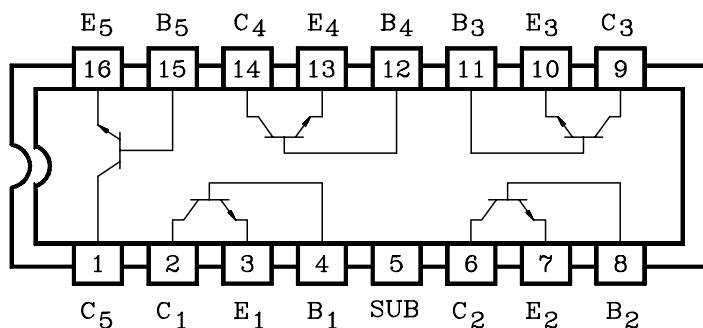

KID65501P/F ~ KID65507P/F

SCHEMATICS

KID65501P/F

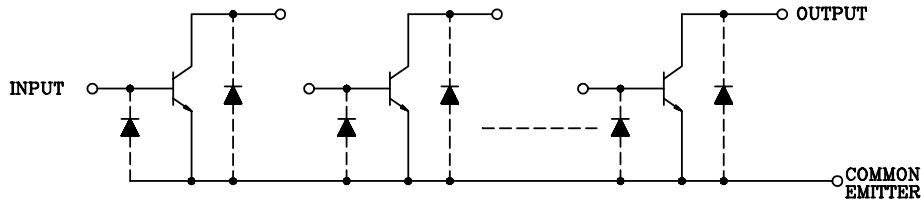

KID65502P/F

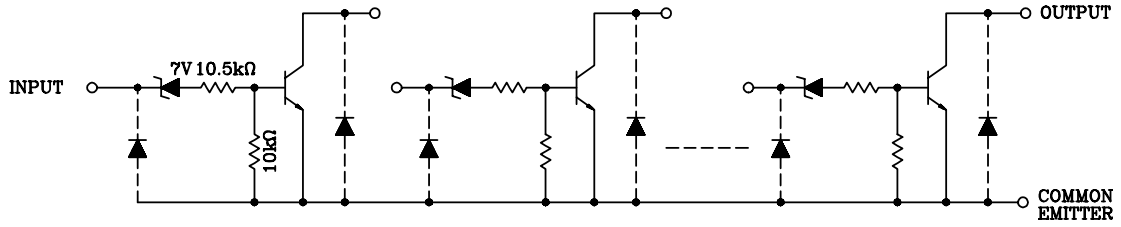

KID65503P/F

KID65504P/F

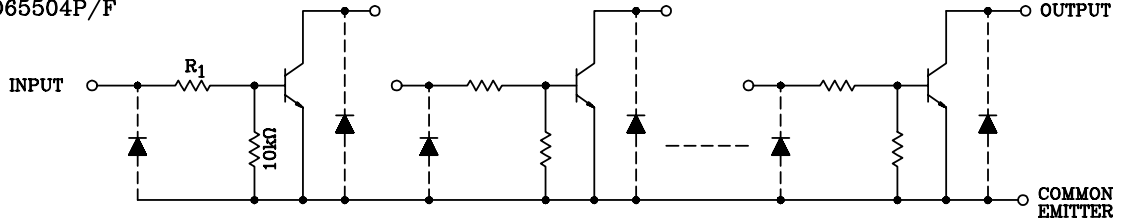

KID65503P/F : R₁ = 2.7kΩ, KID65504P/F : R₁ = 10.5kΩ

KID65505P/F

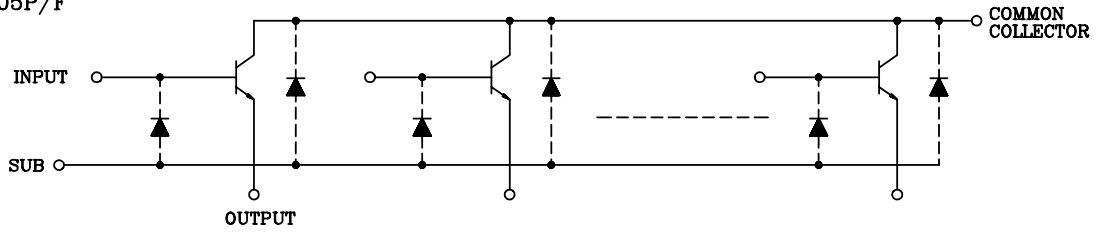

KID65506P/F

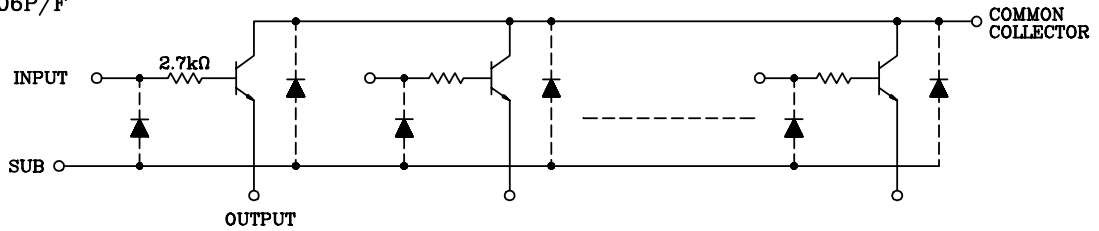

KID65507P/F

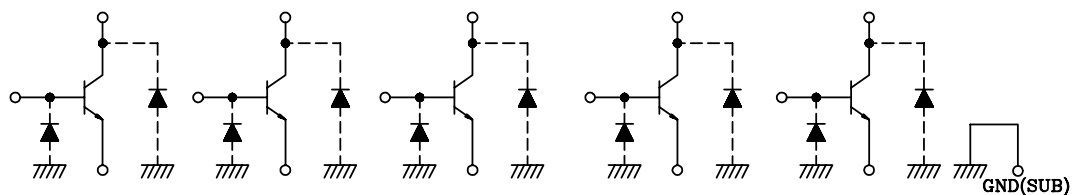

KID65501P/F ~ KID65507P/F

RECOMMENDED OPERATING CONDITIONS (Ta=-30~+75°C)

CHARACTERISTIC		SYMBOL	CONDITION	MIN.	TYP.	MAX.	UNIT
Collector-Emitter Voltage		V_{CE0}		0	-	35	V
Collector-Base Voltage		V_{CB0}		0	-	50	V
Collector Current		I_C		0	-	150	mA
Input Voltage	KID65506P/F	V_{IN}		0	-	35	V
	KID65502P/F			0	-	25	
	KID65503P/F			0	-	25	
	KID65504P/F			0	-	25	
Input Current		I_{IN}		0	-	10	mA
Power Dissipation	KID65501P~ KID65507P	P_D		-	-	0.36	W
	KID65501F~ KID65507F		On PCB *	-	-	0.325	

* : 30×30×1.6mm, Cu 50%

ELECTRICAL CHARACTERISTICS (Ta=25°C)

CHARACTERISTIC	SYMBOL	TEST CIRCUIT	TEST CONDITION	MIN.	TYP.	MAX.	UNIT	
Output Leak Current	I_{CEX}	1	$V_{CE}=25V, V_{IN}=0$	-	-	10	μA	
Collector-Emitter Saturation Voltage	$V_{CE(sat)}$	2	$I_{IN}=1mA, I_C=10mA$	-	-	0.2	V	
			$I_{IN}=3mA, I_C=150mA^*$	-	-	0.8		
DC Forward Current Transfer Ratio	h_{FE}	2	$V_{CE}=10V, I_C=10mA$	**	70	-		
				***	50	-		
Input Voltage (Output ON)	$V_{IN(ON)}$	3	$I_{IN}=1mA, I_C=10mA$	KID65502P/F	13	17	23	V
				KID65503P/F	2.4	3.4	4.2	
				KID65504P/F	7.5	11.5	15	
Turn-ON Delay	t_{ON}	4	$V_{OUT}=35V, R_L=175\Omega, C_L=15pF$	-	50	-	nS	
Turn-OFF Delay	t_{OFF}			-	200	-		

* EXCEPT KID65502P/F

** KID65501P/F, KID65505P/F, KID65506P/F, KID65507P/F

*** KID65502P/F, KID65503P/F, KID65504P/F

KID65501P/F ~ KID65507P/F

1. I_{CEX}

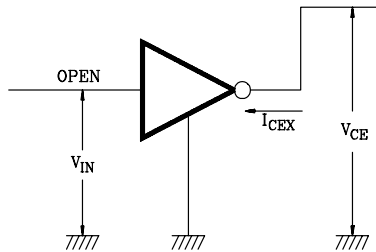

2. $h_{FE}, V_{CE(sat)}$

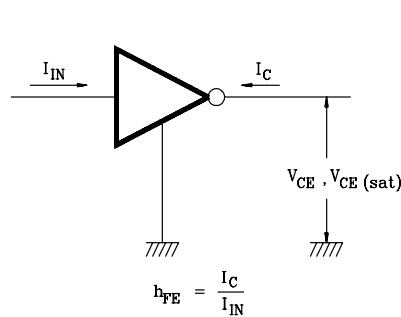

3. $V_{IN(ON)}$

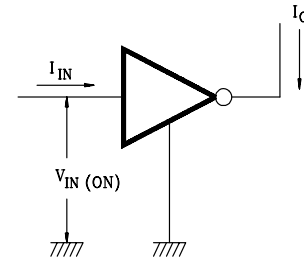

4. t_{ON}, t_{OFF}

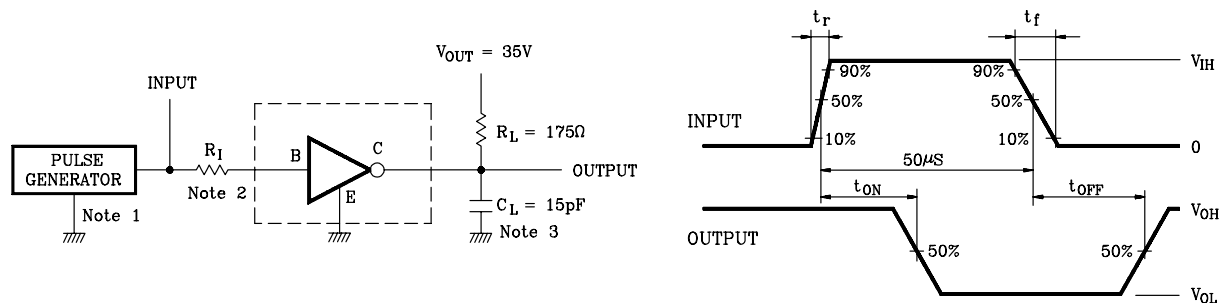

Notes : 1. Pulse Width $50\mu s$, Duty Cycle 10%
Output Impedance 50Ω , $t_r \leq 5ns$, $t_f \leq 10ns$

2. See Below

Input Conditions

Type Number	R_1	V_{III}
KID65501P/F	$2.7k\Omega$	3V
KID65502P/F	0	15V
KID65503P/F	0	3V
KID65504P/F	0	10V
KID65505P/F	$2.7k\Omega$	3V
KID65506P/F	0	3V
KID65507P/F	$2.7k\Omega$	3V

3. C_i Includes Probe and Jig capacitance.