

### Single Darlington Transistor Module 15 Amperes/600 Volts

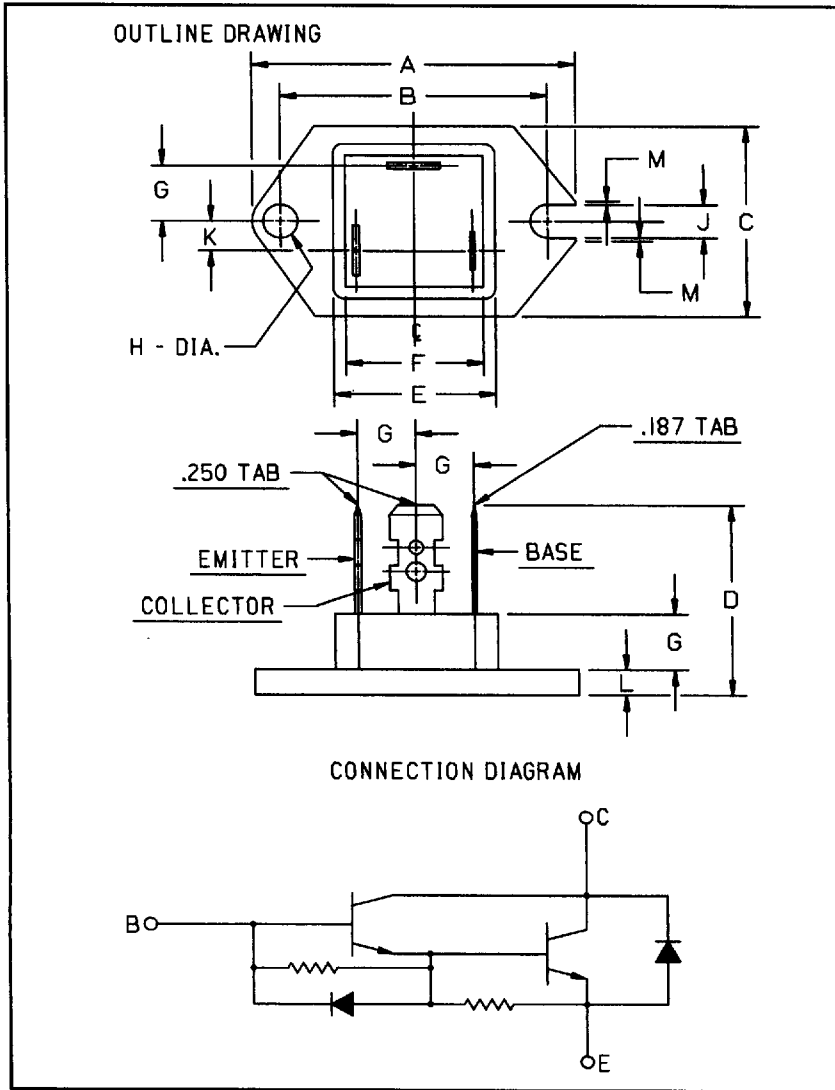

Outline Drawing

Dimensions	Inches	Millimeters
A	1.535 Max.	39 Max.
B	1.268 ± 0.008	32.2 ± 0.2
C	0.945 Max.	24 Max.
D	0.945	24
E	0.768 Max.	19.5 Max.
F	0.656	16.6

Dimensions	Inches	Millimeters
G	0.276	7
H	0.165 ± 0.004 Dia.	4.2 ± 0.1 Dia.
J	0.165	4.2
K	0.146	3.7
L	0.126	3.2
M	0.016	0.4

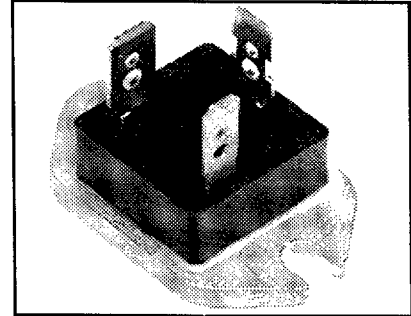

#### Description:

The Powerex Single Darlington Transistor Modules are high power devices designed for use in switching applications. The modules are isolated, consisting of one Darlington Transistor with a reverse parallel connected high-speed diode and base-to-emitter speed-up diode.

#### Features:

- Isolated Mounting
- Planar Chips
- Discrete Fast Recovery Feedback Diode
- High Gain ( $h_{FE}$ )
- TAB Quick-Connect Terminals
- Base-Emitter Speed-up Diode

#### Applications:

- Inverters
- DC Motor Control
- Switching Power Supplies
- AC Motor Control

#### Ordering Information:

Example: Select the complete eight digit module part number you desire from the table - i.e. KS8245A1 is a 450  $V_{CE0(sus)}$  (600  $V_{CEV}$ ), 15 Ampere Single Darlington Module.

Type	$V_{CE0(sus)}$ Volts (X 10)	Current Rating Amperes (15)
KS82	45	A1

7294621 0007983 843



Powerex, Inc., 200 Hillis Street, Youngwood, Pennsylvania 15697-1800 (412) 925-7272

**KS8245A1**

**Single Darlington Transistor Module**

15 Amperes/600 Volts

**Absolute Maximum Ratings,  $T_j = 25\text{ }^\circ\text{C}$  unless otherwise specified**

Ratings	Symbol	KS524503	Units
Junction Temperature	$T_j$	-40 to 150	$^\circ\text{C}$
Storage Temperature	$T_{stg}$	-40 to 125	$^\circ\text{C}$
Collector-Emitter Sustaining Voltage	$V_{CEO(sus)}$	450	Volts
Collector-Base Voltage	$V_{CBO}$	600	Volts
Emitter-Base Voltage	$V_{EBO}$	7	Volts
Collector-Emitter Voltage	$V_{CEV}$	600	Volts
Continuous Collector Current	$I_C$	15	Amperes
Diode Forward Current	$I_{FM}$	15	Amperes
Continuous Base Current	$I_B$	0.9	Amperes
Diode Surge Current	$I_{FSM}$	150	Amperes
Power Dissipation	$P_t$	100	Watts
Max. Mounting Torque M4 Terminal Screws	-	12	in.-lb.
Module Weight (Typical)	-	25	Grams
V Isolation	$V_{RMS}$	2000	Volts

**Electrical Characteristics,  $T_j = 25\text{ }^\circ\text{C}$  unless otherwise specified**

Characteristics	Symbol	Test Conditions	Min.	Typ.	Max.	Units
Collector Cutoff Current	$I_{CEV}$	$V_{CE} = V_{CEV}, V_{BE} = -2V$	-	-	1	mA
		$V_{CE} = 600V, V_{BE} = -2V, T_C = 125^\circ\text{C}$	-	-	5	mA
Emitter Cutoff Current	$I_{EBO}$	$V_{EB} = 7V$	-	-	50	mA
DC Current Gain	$h_{FE}$	$I_C = 15A, V_{CE} = 2V$	50	-	-	-
		$I_C = 15A, V_{CE} = 5V$	100	-	-	-
Diode Forward Voltage	$V_{FM}$	$I_{FM} = 15A$	-	-	1.5	Volts
Collector-Emitter Saturation Voltage	$V_{CE(sat)}$	$I_C = 15A, I_B = 0.3A$	-	-	2.0	Volts
Base-Emitter Saturation Voltage	$V_{BE(sat)}$	$I_C = 15A, I_B = 0.3A$	-	-	2.5	Volts
Resistive	Turn-on	$V_{CC} = 300V$	-	-	1.5	$\mu\text{s}$
	Storage Time		$I_C = 15A$	-	-	8.0
Switch Times	Fall Time	$I_{B1} = 0.3A, I_{B2} = -0.3A$	-	-	3.0	$\mu\text{s}$

**Thermal and Mechanical Characteristics,  $T_j = 25\text{ }^\circ\text{C}$  unless otherwise specified**

Characteristics	Symbol	Test Conditions	Min.	Typ.	Max.	Units
Thermal Resistance, Case-to-Sink	$R_{\theta(c-s)}$	-	-	-	0.4	$^\circ\text{C/W}$
Thermal Resistance, Junction-to-Case	$R_{\theta(j-c)}$	Transistor Part	-	-	1.2	$^\circ\text{C/W}$
Thermal Resistance, Junction-to-Case	$R_{\theta(j-c)}$	Diode Part	-	-	2.15	$^\circ\text{C/W}$

**KS8245A1**  
**Single Darlington Transistor Module**  
**15 Amperes/600 Volts**

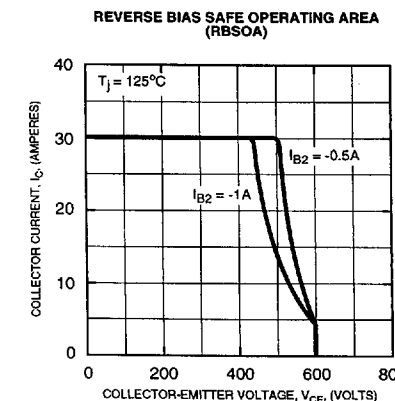
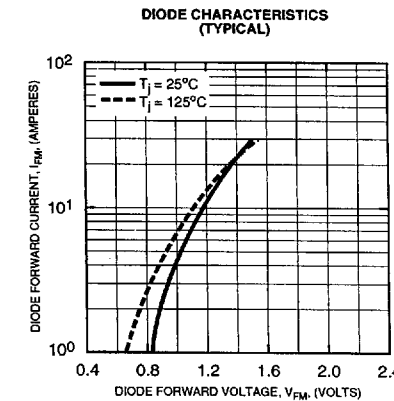
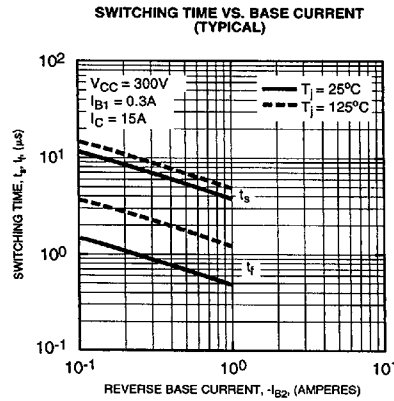
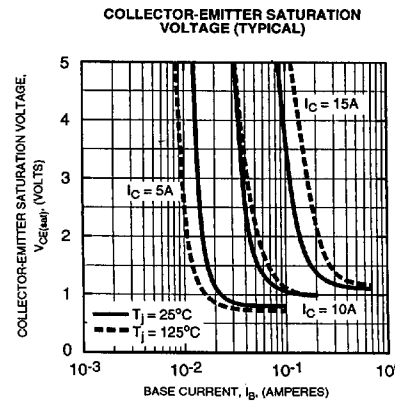
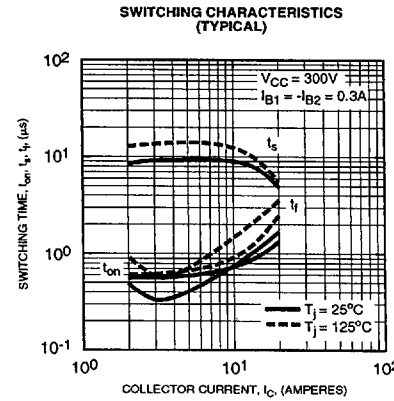
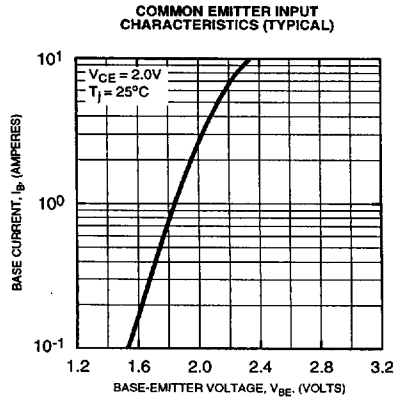
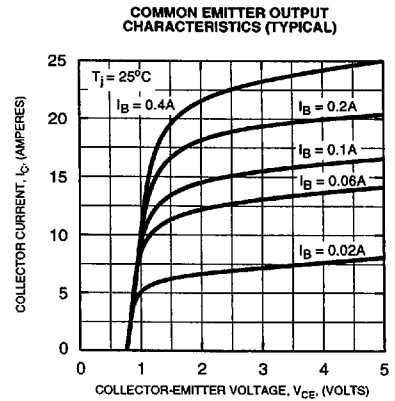
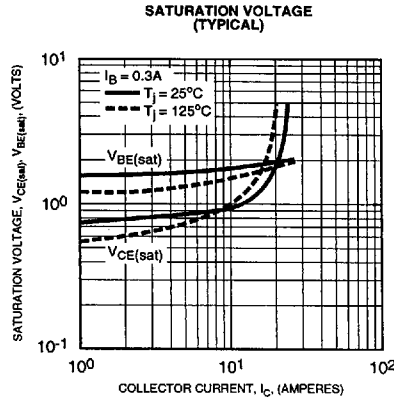
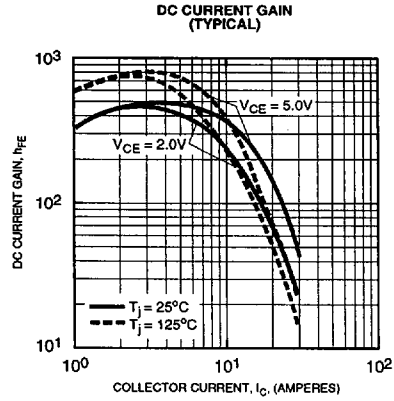

7294621 0007985 616

**KS8245A1**  
**Single Darlington Transistor Module**  
 15 Amperes/600 Volts

**FORWARD BIAS SAFE OPERATING AREA (SOA)**

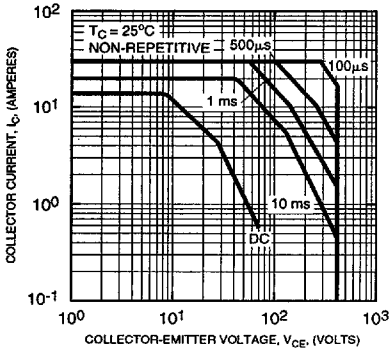

**DERATING FACTOR OF SAFE OPERATING AREA (SOA)**

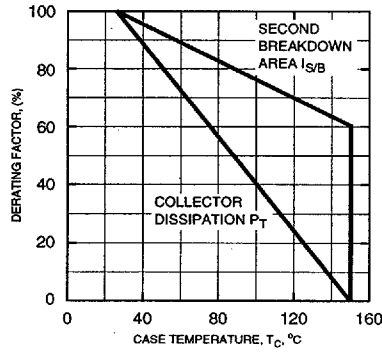

**REVERSE RECOVERY CHARACTERISTICS OF FREE-WHEEL DIODE (TYPICAL)**

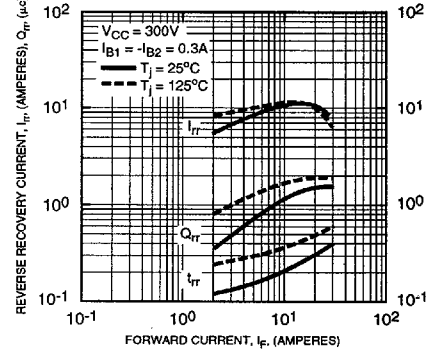

**DIODE FORWARD SURGE CURRENT**

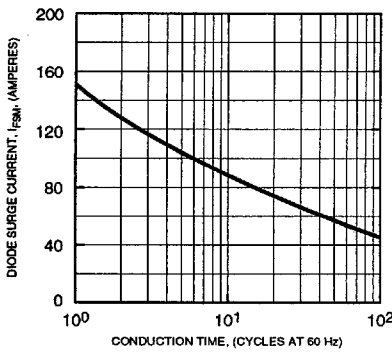

**TRANSIENT THERMAL IMPEDANCE CHARACTERISTICS (TRANSISTOR)**

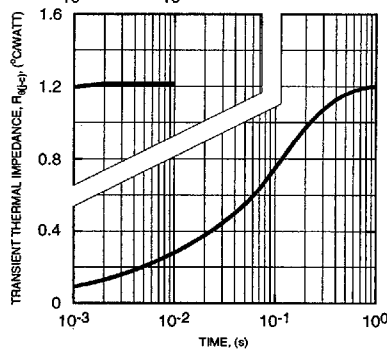

**TRANSIENT THERMAL IMPEDANCE CHARACTERISTICS (DIODE)**

