

**SLIC KIT OPTIMIZED FOR APPLICATIONS WITH BOTH
FIRST AND SECOND GENERATION COMBOS**

PRELIMINARY DATA

- PROGRAMMABLE DC FEED RESISTANCE AND LIMITING CURRENT (25/40/60mA)
- LOW ON-HOOK POWER DISSIPATION (50mW typ)
- SIGNALLING FUNCTION (off-hook/GND-Key)
- QUICK OFF-HOOK DETECTION IN CVS FOR LOW DISTORTION (< 1 %) DIAL PULSE DETECTION
- HYBRID FUNCTION
- RINGING GENERATION WITH QUASI ZERO OUTPUT IMPEDANCE, ZERO CROSSING INJECTION (no ext. relay needed) AND RING TRIP DETECTION
- ABSOLUTELY NO NOISE INJECTED ON ADJACENT LINES DURING RINGING SEQUENCE
- AUTOMATIC RINGING STOP WHEN OFF-HOOK IS DETECTED
- TEST MODE ALLOWS LINE LENGTH MEASUREMENT
- PARALLEL LATCHED DIGITAL INTERFACE
- LOW NUMBER OF EXTERNAL COMPONENTS WITH STANDARD TOLERANCE ONLY : 9 1% RESISTORS AND 5 10-20% CAPACITORS (for 600 ohm appl.)
- POSSIBILITY TO WORK ALSO WITH HIGH COMMON MODE CURRENTS
- GOOD REJECTION OF THE NOISE ON BATTERY VOLTAGE (20dB at 10Hz ; 35dB at 1KHz)
- INTEGRATED THERMAL PROTECTION
- SURFACE MOUNT PACKAGE (PLCC28 + PowerSO-20)
- 0°C TO 70°C: L3000N/L3092
- -40°C TO +85°C: L3000NT/L3092T

DESCRIPTION

The SLIC KIT (L3000N/L3092) is a set of solid state devices designed to integrate many of the functions needed to interface a telephone line. It consists of 2 integrated devices ; the L3000N line interface circuit and the L3092 control unit.

The kit implements the main features of the BORSHT functions:

- Battery feed (balance mode)
- Ringing Injection

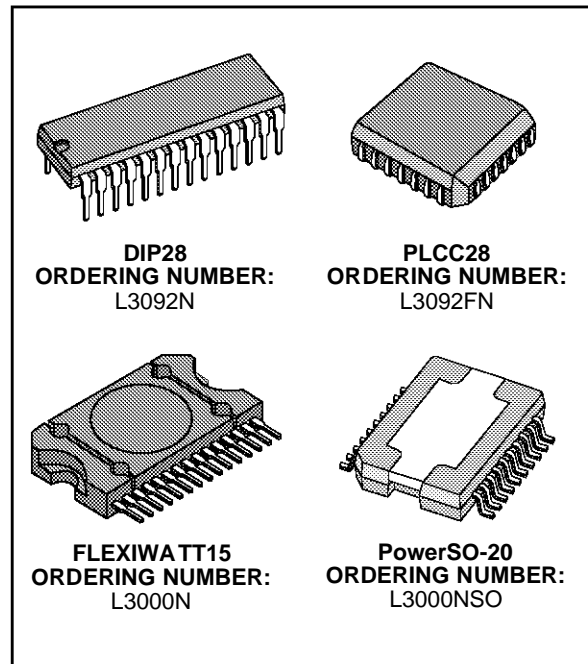

- Signalling Detection
- Hybrid Function

The SLIC KIT injects the ringing signal in balanced mode and requires a positive supply voltage of typically + 72V to be available on the subscriber card.

The L3000N/L3092 kit generates the ringing signal internally, avoiding the requirement for expensive external circuitry. A low level 1.5Vrms input is required. (This can be provided by the combo).

A special operating mode limits the SLIC KIT power dissipation to 50mW in on-hook condition keeping the on/off hook detection circuit active.

Through the Digital Interface it is also possible to set an operating mode that allows measurements of loop resistance and therefore of line length.

This kit is fabricated using a 140V Bipolar technology for L3000N and a 12V Bipolar I²L technology for L3092.

Both devices are available PTH application (FLEXIWATT15 and DIP28) or SMD application (PowerSO-20 and PLCC28).

This kit is specially suitable to Private Automatic Branch Exchange (PABX) and Low Range C.O. Applications.

PIN CONNECTIONS

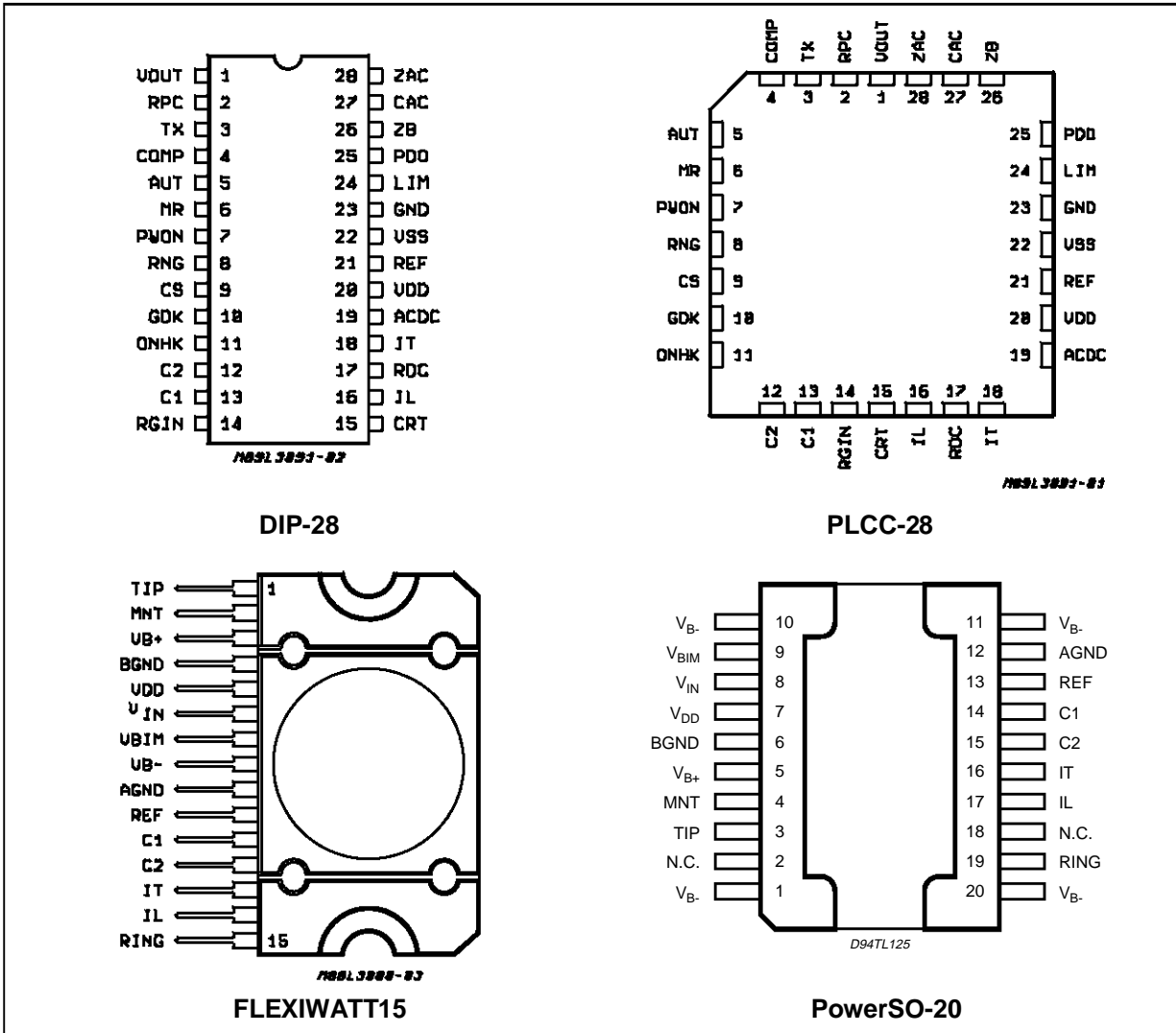

ABSOLUTE MAXIMUM RATINGS

Symbol	Parameter	Value	Unit
V_{b-}	Negative Battery Voltage	-80	V
V_{b+}	Positive Battery Voltage	80	V
$ V_{b-} + V_{b+} $	Total Battery Voltage	140	V
V_{dd}	Positive Supply Voltage	+6	V
V_{ss}	Negative Supply Voltage	-6	V
$V_{agnd}-V_{bgnd}$	Max. Voltage between Analog Ground and Battery Ground	5	V
T_j	Max. Junction Temperature	+150	°C
T_{stg}	Storage Temperature	-55 to +150	°C

THERMAL DATA

Symbol	Parameter	Value	Unit
L3000N HIGH VOLTAGE			
R _{th j-case}	Thermal Resistance Junction to case (FLEXIWATT15)	Max. 4	°C/W
R _{th j-amb}	Thermal Resistance Junction to ambient (FLEXIWATT15)	Max. 50	°C/W
R _{th j-case}	Thermal Resistance Junction to case (PowerSO-20)	Typ. 2	°C/W
R _{th j-amb}	Thermal Resistance Junction to ambient (PowerSO-20)	Max. 60	°C/W
L3092 LOW VOLTAGE			
R _{th j-amb}	Thermal Resistance Junction to ambient	Max. 80	°C/W

OPERATING RANGE

Symbol	Parameter	Min.	Typ.	Max.	Unit
T _{oper}	Operating Temperature Range for L3000N/L3092 L3000NT/L3092T	0 -40		70 +85	°C °C
V _{b-}	Negative Battery Voltage	-70	-48	-20	V
V _{b+}	Positive Battery Voltage	0	+72	+75	V
V _{b-} + V _{b+}	Total Battery Voltage		120	130	V
V _{dd}	Positive Supply Voltage	+4.5		+5.5	V
V _{ss}	Negative Supply Voltage	-5.5		-4.5	V

PIN DESCRIPTION (L3000N)

FLEX. N°	SO-P. N°	Name	Description
1	3	TIP	A line termination output with current capability up to 100mA (I _s is the current sourced from this pin).
2	4	MNT	Positive Supply Voltage Monitor.
3	5	V _{B+}	Positive Battery Supply Voltage.
4	6	BGND	Battery ground relative to the V _{S+} and the V _{B-} supply voltages. It is also the reference ground for TIP and RING signals.
5	7	V _{DD}	Positive Power Supply +5V.
6	8	V _{IN}	2 wire unbalanced voltage input.
7	9	VBIM	Output voltage without current capability, with the following functions: - give an image of the total battery voltage scaled by 40 to the low voltage part. - filter by an external capacitor the noise on .
8	1,10,11,20	V _{B-}	Negative Battery Supply Voltage.
9	12	AGND	Analog Ground. All input signals and the V _{DD} supply voltage must be referred to this pin.
10	13	REF	Voltage reference output with very low temperature coefficient. The connected resistor sets Internal circuit bias current.
11	14	C1	Digital signal input (3 levels) that defines device status with pin 12.
12	15	C2	Digital signal input (3 levels) that defines device status with pin 11.
13	16	I _T	High precision scaled transversal line current signal. $I_T = \frac{I_a + I_b}{100}$
14	17	I _L	Scaled longitudinal line current signal. $I_L = \frac{I_a - I_b}{100}$
15	19	RING	B line termination output with current capability up to 100mA (I _b is the current sunk into this pin).
-	2, 18	N.C.	Not connected.

Notes: 1) Unless otherwise specified all the diagrams in this datasheet refers to the FLEXIWATT15 pin connection.

2) All information relative to the PowerSO-20 package option should be considered as advanced information on a new product now in development or undergoing evaluation. Details are subject to change without notice.

PIN DESCRIPTION (L3092)

N°	Name	Description
1	VOUT	Two wire unbalanced output carrying out the following signals reduced by 40: 1) DC voltage to perform the proper DC characteristic. 2) Ringing Signal 3) Voice Signal
2	RPC	AC line Impedance Adjustment Protection Resistances Compensation
3	TX	Transmit Amplifier Output
4	COMP	Comparator Input. This is the input comparator that senses the line voltage in power down and in automatic stand-by, allowing off hook detection in this mode.
5	AUT	Aut. Input. It is a part of the digital interface. Loaded when CS is low.
6	MR	Master Reset Input. When it is connected to ground the SLIC is forced in power down. It has an internal pull-up. (typ. 200KΩ) (*)
7	PWON	Power on/power off input. This input is part of digital interface. Loaded when CS is low.
8	RING	Ring Enable Input. This input is part of the digital interface. Loaded when CS is low.
9	CS	Chip Select Input.
10	GDK	Ground Key Output Enabled by CS Low.
11	ONHK	On Hook/off Hook Output Enabled by CS Low.
12	C2	State control Signal 2.
13	C1	State Control Signal 1. Combination of C1 and C2 define operating mode of the high voltage part.
14	RGIN	Low Level Ringing Signal Input.
15	CRT	Ring Trip Detection
16	IL	Longitudinal Line Current Input $IL = \frac{I_b - I_a}{100}$
17	RDC	DC Feeding System
18	IT	Transversal Line Current Input $IT = \frac{I_a + I_b}{100}$
19	ACDC	AC - DC Feedback Input.
20	VDD	Positive Supply Voltage, +5V.
21	REF	Bias Setting Pin.
22	VSS	Negative Supply Voltage, -5V.
23	GND	Analog and Digital Ground.
24	LIM	Limiting Current Selection Input. Loaded when CS is low.
25	PDO	Power Down Output. Driving the high voltage part L3000N through the bias resistor RH.
26	ZB	TX Amplifier Negative Input performing the two to four wire conversion. In case of application with 2nd Generation COMBO performing also the echo cancellation (ex TS5070/5071), this pin must be connected to GND.
27	CAC	AC Feedback Input.
28	ZAC	AC Line Impedance Synthesis.

(*) Must be connected to a proper capacitor for power on reset or to V_{DD} if not used. Should not be left open.

L3000N BLOCK DIAGRAM

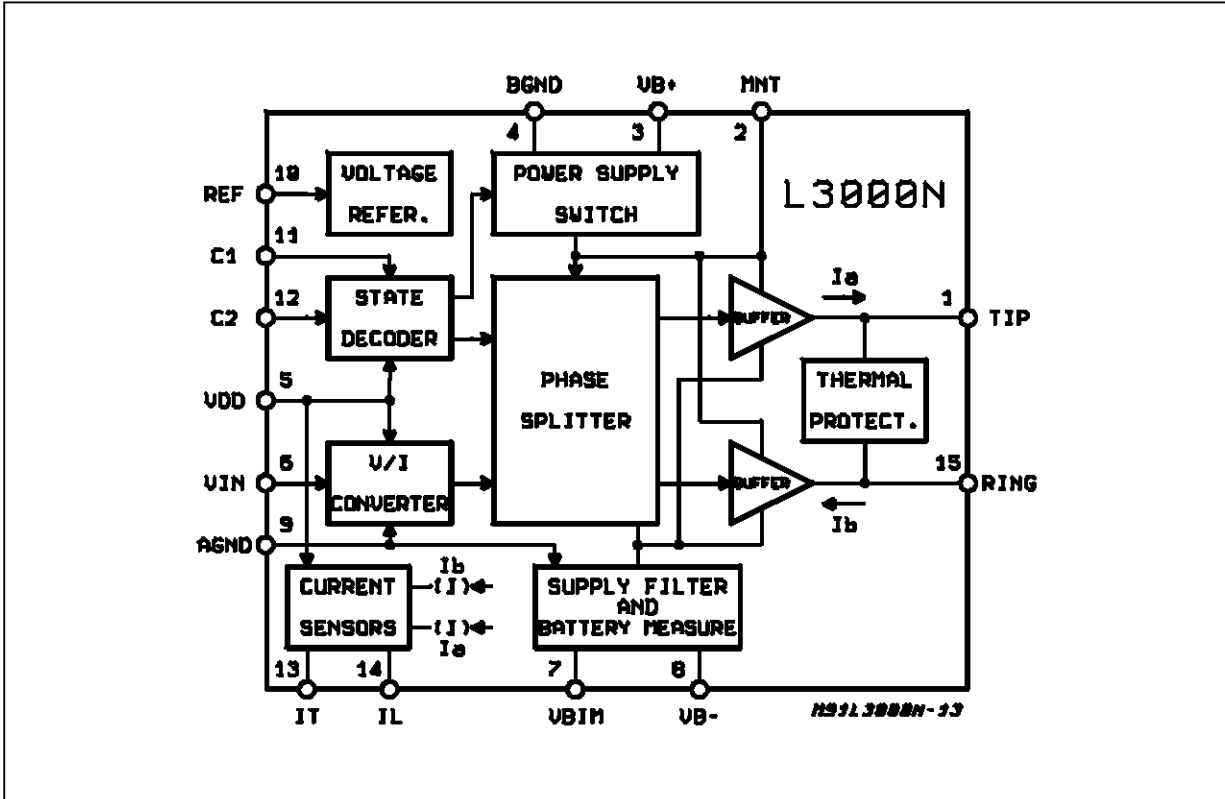

L3092 BLOCK DIAGRAM

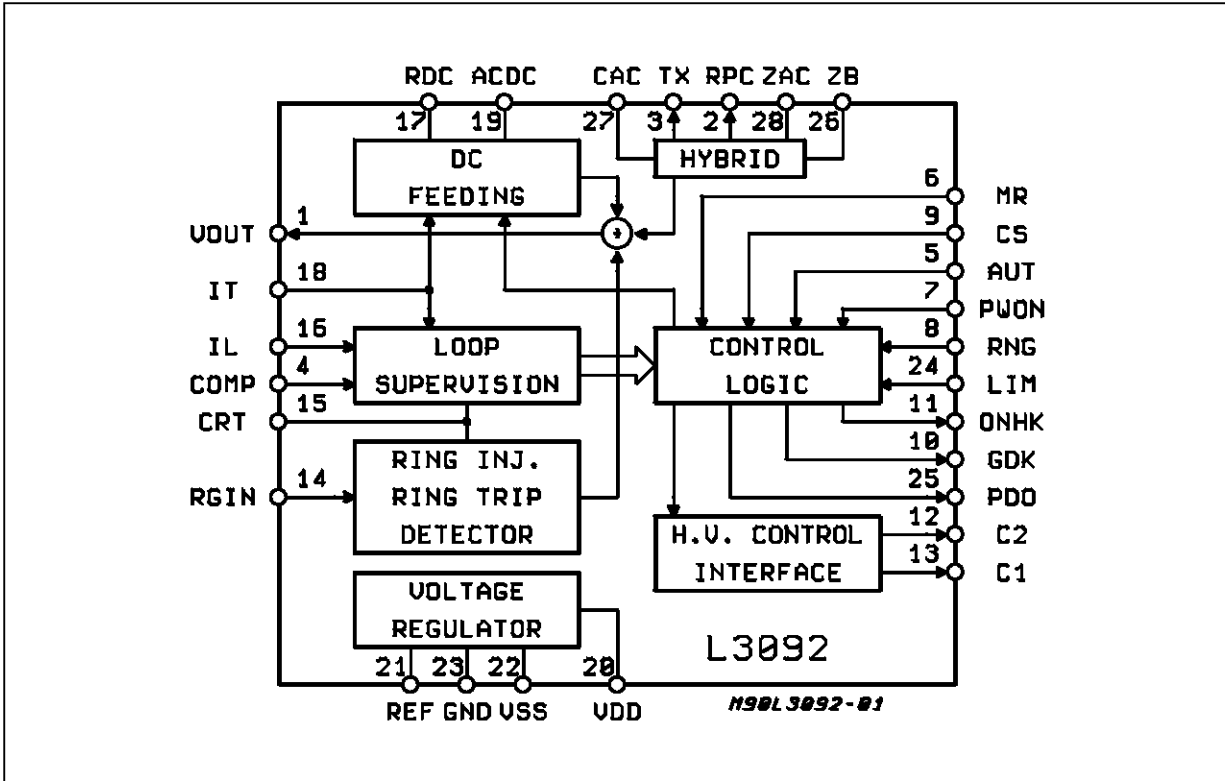

FUNCTIONAL DIAGRAM

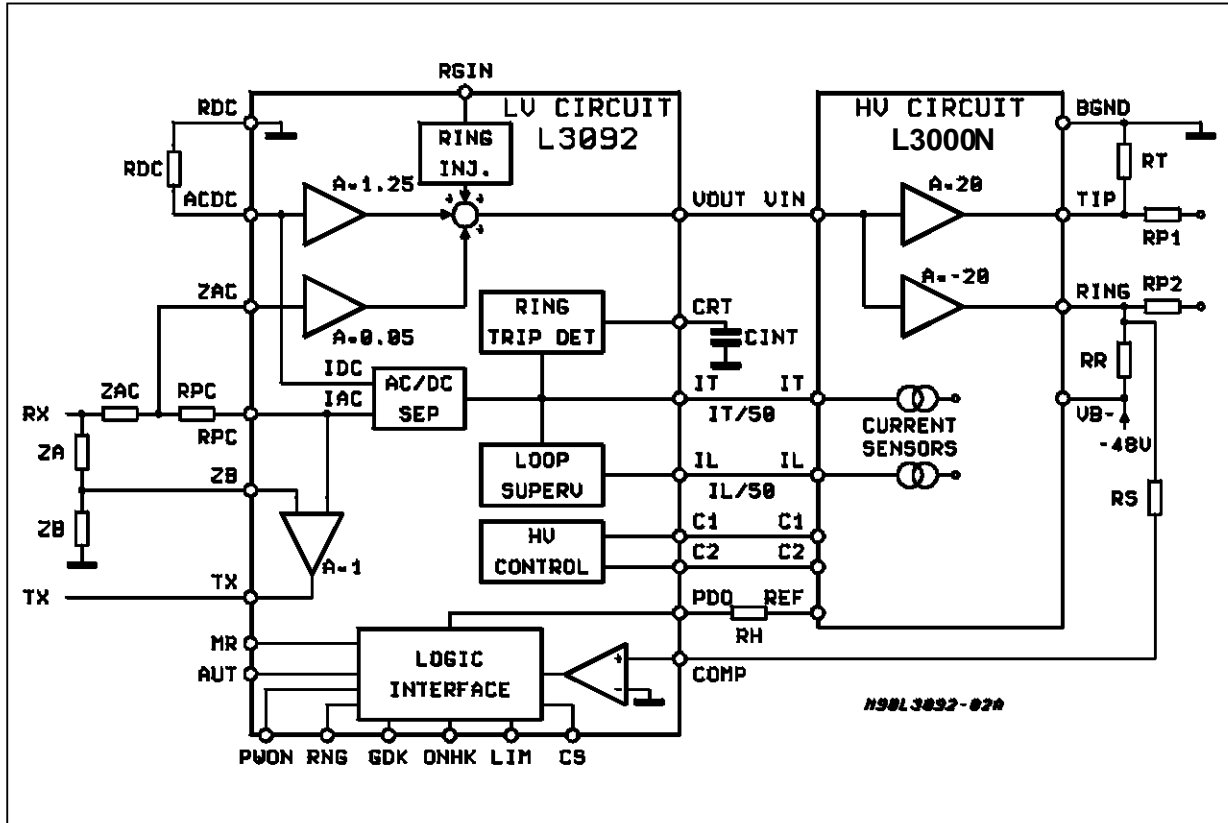

FUNCTIONAL DESCRIPTION

L3000N - HIGH VOLTAGE CIRCUIT

The L3000N line interface provides battery feed for telephone lines and ringing injection. Both these operations are done in Balance Mode. This is very important in order to avoid the generation of common mode signals in particular during the pulse dialling operation of the telephone set connected to the SLIC. The IC contains a state decoder that under external control can force the following operational modes : stand-by, conversation and ringing.

In addition Power down mode can be forced connecting the bias current resistor to V_{DD} or leaving it open.

Two pins, I_L and I_T , carry out the information concerning line status which is detected by sensing the line current into the output stage.

The L3000N amplifies both the AC and DC signals entering at pin 6 (VIN) by a factor equal to 40.

Separate grounds are provided :

- Analog ground as reference for analog signals
- Battery ground as a reference for the output stages

The two ground should be shorted together at a low impedance point.

L3092 - LOW VOLTAGE CIRCUIT

The L3092 Low Voltage Control Unit controls the L3000N line interface module providing set up data to set line feed characteristics and to inject ringing. An on chip digital parallel interface allows a microprocessor or a second generation COMBO as the TS5070 to control all the operations.

L3092 defines working states of Line Interface Circuit and also informs the card controller about line status.

L3000N WORKING STATES

In order to carry out the different possible operations, the L3000N has several different working states. Each state is defined by the voltage respectively applied by pin 12 and 13 of L3092 to the pins 12 and 11 of L3000N.

Three different voltage levels (-3, 0, +3) are available at each connection, so defining nine possible states as listed in tab. 1.

Appropriate combinations of two pins define four of the five possible L3000N working states that are:

- a) Stand-by (SBY)
- b) Conversation (CVS)

Table 1.

		Pin 12 of L3092 Pin 12 of L3000N (C2)		
		+3	0	-3
Pin 13 of L3092 (C1)	+3	Stand-by	Conversation	Not Used
	0	Not Used	B.B	Not Used
Pin 11 of L3000N	-3	Not Used	Ringing	Not Used

c) Ringing (RING)

d) Boost Battery (BB),(see Appendix B).

The fifth status, Power down (PD), is set by the output pin PDO of the L3092 that disconnect the Bias Resistor, RH, of L3000N from ground.

The main difference between Stand-by and Power down is that in SBY the power consumption on the voltage battery VB- (-48V) is reduced but the L3000N DC Feeding and monitoring circuits are still active, in PD the power consumption on VB- is reduced to zero, and the L3000N is completely switched off.

SLIC OPERATING MODES

Through the L3092 Digital Interface it is possible to select six different SLIC OPERATING MODES :

- 1) Conversation or Active Mode (CVS)
- 2) Stand - By Mode (SBY)
- 3) Power - Down Mode (PD)
- 4) Automatic Stand - By Mode (ASBY)
- 5) Test Mode (TS)
- 6) Ringing Mode (RNG)

1) CONVERSATION (CVS) OR ACTIVE MODE

This operating mode is set by the control processor when the Off hook condition has been recognized,

As far as the DC Characteristic is concerned two different feeding conditions are present :

a) Current limiting region : the DC impedance of the SLIC is very high (> 20KΩ) and therefore the system works like a current generator. By the L3092 Digital Interface it is possible to select the value of the limiting current.:

60mA, 40mA or 25mA.

b) A standard resistive feeding mode : the characteristic is equal to a battery voltage (VB-) minus 5V, in series with a resistor, whose value is set by external components (see external component list of L3092).

Switching between the two regions is automatic without discontinuity, and depends on the loop resistance. The SLIC AC characteristics are guaranteed in both regions.

Fig. 1 shows the DC characteristic in conversa-

tion mode.

Fig. 2 shows the line current versus loop resistance for two different battery values and RFS = 200Ω.

The allowed maximum loop resistance depends on the values of the battery voltage (VB), on the RFS and on the value of the longitudinal current (IGDK). With a battery voltage of 48V, RFS = 200Ω and IGDK = 0mA, the maximum loop resistance is over 3000Ω and with IGDK = 20mA is about 2000Ω (see Application Note on maximum loop resistance for L3000N/L3092 SLIC KIT).

In conversation mode the AC impedance at the line terminals is synthesized by the external components ZAC and RP, according to the following formula :

$$ZML = \frac{ZAC}{25} + 2 \cdot RP$$

Depending the characteristic of the ZAC network, ZML can be either a pure resistance or a complex impedance. This allows for ST SLIC to meet different standards as far as the return loss is concerned. The capacitor CCOMP guarantees stability to the system.

The two to four wire conversion is achieved by means of a circuit that can be represented as a Wheatstone bridge, the branches of which being:

- 1) The line impedance (Zline).
- 2) The SLIC impedance at line terminals (ZML).
- 3) The balancing network ZA connected between RX input and ZB pin of L3092.
- 4) The network ZB between ZB pin and ground that shall copy the line impedance.

It is important to underline that ZA and ZB are not equal to ZML and to Zline. They both must be multiplied by a factor in the range of 10 to 25, allowing use of smaller capacitors.

In case the L3000N/L3092 kit is used with a second generation programmable COMBO (EG TS5070FN) which is able to perform the two to four wire conversion, the two impedances ZA and ZB can be removed and the ZB pin connected to GND.

The -6dB Tx gain of the L3000N/L3092 SLIC kit in fact allows to keep the echo signal always within the COMBO Hybrid Balance Filter dynamic range.

In conversation mode, the L3000N dissipates about 250mW for its own operation. The dissipation related to the current supplied to the line shall be added, in order to get the total dissipation.

In the same condition the power dissipation of L3092 is typically 100mW.

Figure 1: DC Characteristics in Conversation Mode

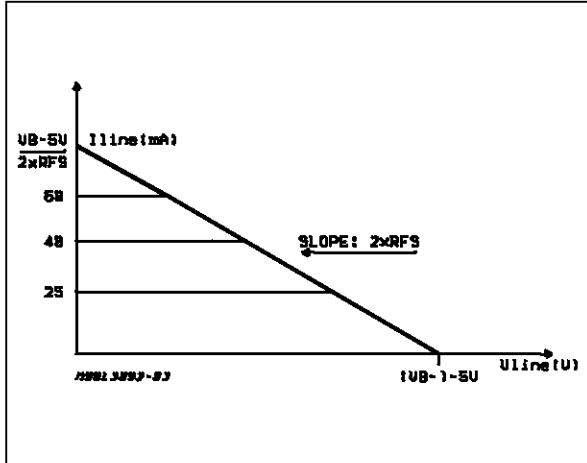
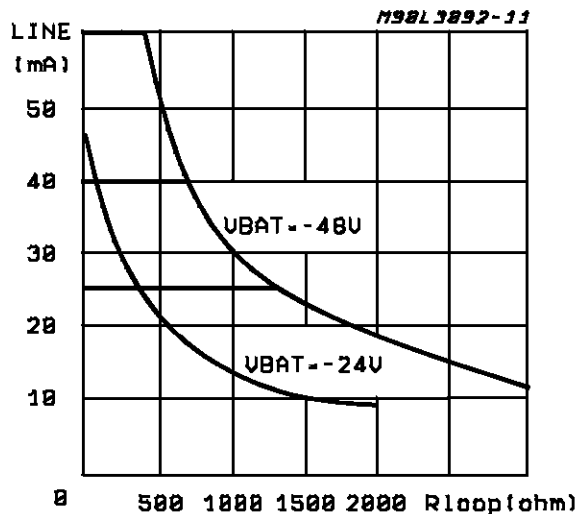

Figure 2: Line Current versus Loop Resistance - RFS = 200Ω; Limiting Currents: 25/40/60mA



2) STAND-BY (SBY) MODE

In this mode the bias currents of both L3000N and L3092 are reduced as only some parts of the two circuits are completely active, control interface and current sensors among them. The current supplied to the line is limited at 10mA, and the slope of the DC characteristic corresponds to 2 x RFS.

The AC characteristic in Stand-by corresponds to a low impedance (2 x RP)

In Stand-by mode the line voltage polarity is just in direct condition, that is the TIP wire more positive than the RING one as in Conversation Mode.

When the SLIC is in Stand-by mode, the power dissipation of L3000N does not exceed 120mW from - 48V) eventually increased of a certain amount if some current is flowing into the line.

The power dissipation of the L3092 in the same condition is typically 50mW.

SBY Mode is usually selected when the telephone is in on-hook. It allows a proper off-hook detection also in presence of high common mode line current or with telephone set sinking few milliAmpere of line current in on hook condition.

Figure 3: DC Characteristics in Stand-by Mode

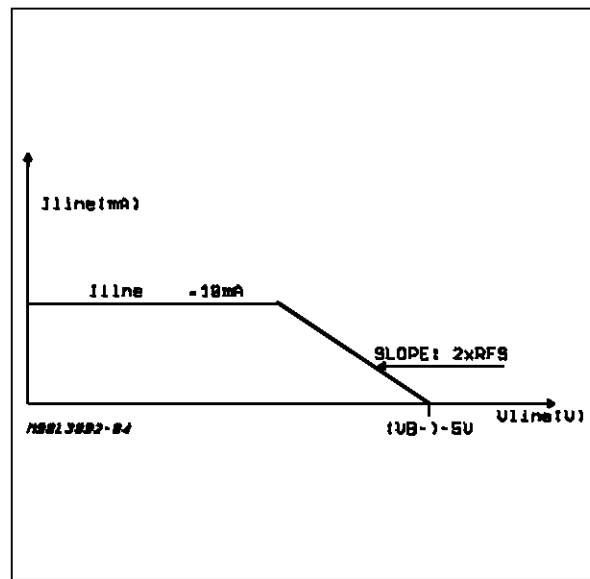

3) POWER DOWN (PD) MODE

In this mode the L3000N present a high impedance (> 1 Mohm) to the line and cannot feed any line current.

The L3092 forces L3000N in Power Down disconnecting its bias Resistor, RH, from the ground through the output pin PD0.

The power dissipation from the battery voltage (-VB) is almost equal to zero and the power dissipation of L3092 is typically 50mW.

The PD mode is normally used in emergency condition but can be used also in normal on-hook condition.

In this case the off-hook detection is performed using the line sense comparator integrated in the L3092.

The fig. 4 shows the functional circuit to perform the off hook detection in Power down mode.

The resistor RR and RT feed the line current. The voltage at the terminal of the resistor RS connected to RING wire is normally - 48V.

When there is a loop resistor between TIP and

RING wires the voltage will increase to $-24V$.
 The comparator C1 will change its output voltage from low to high level.
 If the Chip Select input (CS) is low the ONHK output pin will be set to low level ($+0V$) indicating that the off hook condition is present.

This off-hook detection circuit can be influenced by common mode signal present on RING Terminal. The capacitor Cs is used to filter this common mode signal.

In the case of very high common mode signal af-

ter the detection of a low level on the ONHK output pin, it is suggested to set the SLIC in Stand-by. In this operating mode the off-hook detection circuit is not sensitive to the line common mode signal.

If in Stand-by Mode the off-hook detection is not confirmed (ONHK output set to high level) we suggest after few second to set the SLIC again in Power Down Mode.

Total operation is managed by line card controller.

Figure 4: Off-hook Detection Circuit in Power Down Mode

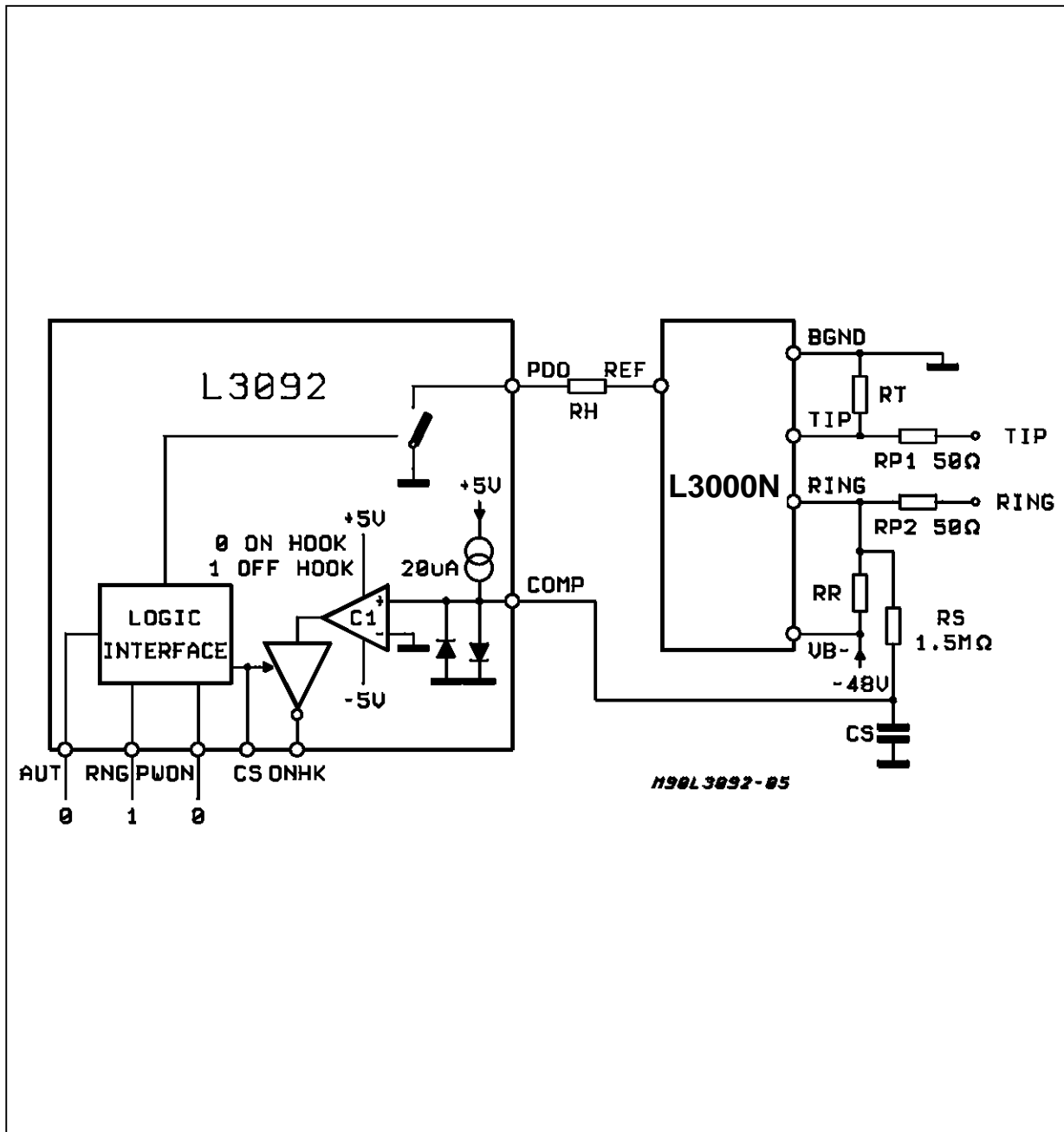
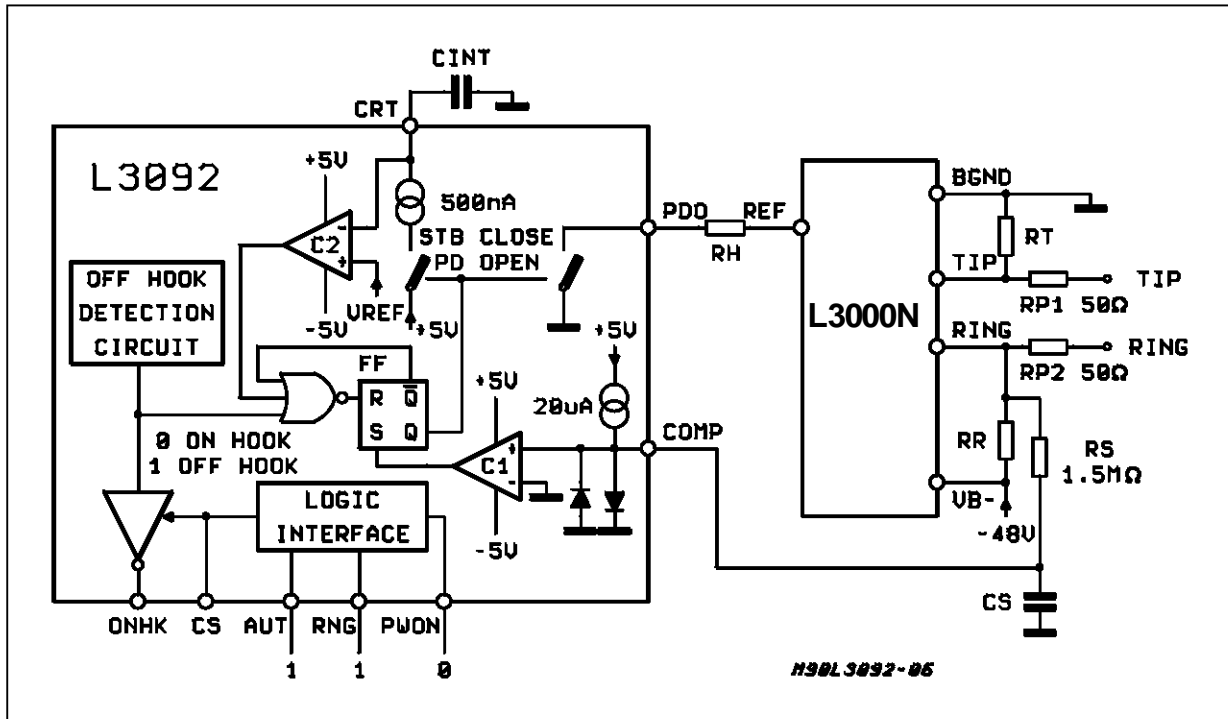

Figure 5: Off-hook Detection Circuit in Automatic Standby Mode



4) AUTOMATIC STAND - BY (ASB) MODE

This is an operating mode similar to the Power Down Mode, but with the software procedure to detect off-hook condition integrated in hardware on chip.

Fig. 5 shows the functional circuit activated in this mode.

When the off-hook condition occurs RING wire voltage goes high (from - 48V to - 24V).

The output of the comparator C1 will go high setting the output of the flip - flop FF high.

Therefore L3092 will set L3000N in Stand-by providing a ground signal at pin PDO.

At the same time the external capacitor CINT will be slowly charged.

In Stand-by the internal off-hook Detection circuit will be activated and will check if the off-hook condition detected by the comparator C1 was true or not true.

If the off-hook condition is confirmed the SLIC will be kept in Stand-by Mode and the output ONHK will go low when CS is low.

If the off-hook condition is not confirmed the SLIC will be kept in Stand - By only for a few seconds. (typ. 5sec). When the voltage at CRT out put will reach the V_{REF} value the C2 comparator will reset the FF Flip - Flop and therefore the SLIC will be set again in Power Down.

The Automatic Stand-by (ASBY) Mode combine the key characteristics of Power Down (PD) and

Stand-by (SBY) Modes in particular it is characterized by a very low power consumption (as the Power Down mode) and a sophisticated off hook detection circuit (as the Stand-By mode).

The card controller will receive the off-hook information from the pin ONHK only after that it is checked and confirmed by the internal off-hook detector that is not sensitive to spikes and common mode line signal. Therefore the software required to manage the SLIC will be very simple.

5) TEST (TS) MODE

When this mode is activated the SLIC will be set in conversation mode keeping the initial value of limiting current.

The GDK output pin of L3092 Digital Interface will be set to "0" if the SLIC is operating in the limiting region of the DC characteristic, see fig. 1 and 2. GDK output will be set to 1 if the SLIC is operating in the resistive region.

The SLIC will work in one of the two region depending on the loop resistance and the programmed limiting current value.

By changing the limiting current value selected in conversation mode it is possible to measure the Loop Resistance and therefore the line length connected to the SLIC.

The following table shows the ranges of the loop resistance that set the GDK output pin to high and low level in correspondence of all the possible limiting current values (25/40/60mA) with $R_{FS} = 200\Omega$.

Limiting Current	GDK = 0	GDK = 1
60mA	(0 – 300) ohm	>300 ohm
40mA	(0 – 650) ohm	>650 ohm
25mA	(0 – 1300) ohm	>1300 ohm

If, for example, the loop resistance is 400Ω the GDK output will be 0 only when the limiting current value is 40 or 25mA.

The card controller can program consecutive Test Mode and Conversation Mode with different limiting current in order to individuate the range of loop resistance as shown in the flow chart of fig. 6.

The information of the Loop Resistance Range

can be very useful to optimize the transmission characteristics of the Line Card to each line.

For example, if a second generation COMBO like TS5070 is used the Card Controller can use this information to change the Tx, RX Gains and echo cancellation characteristics into the programmable COMBO improving the quality of the system.

Figure 6: Procedure for Loop Resistance Evaluation.

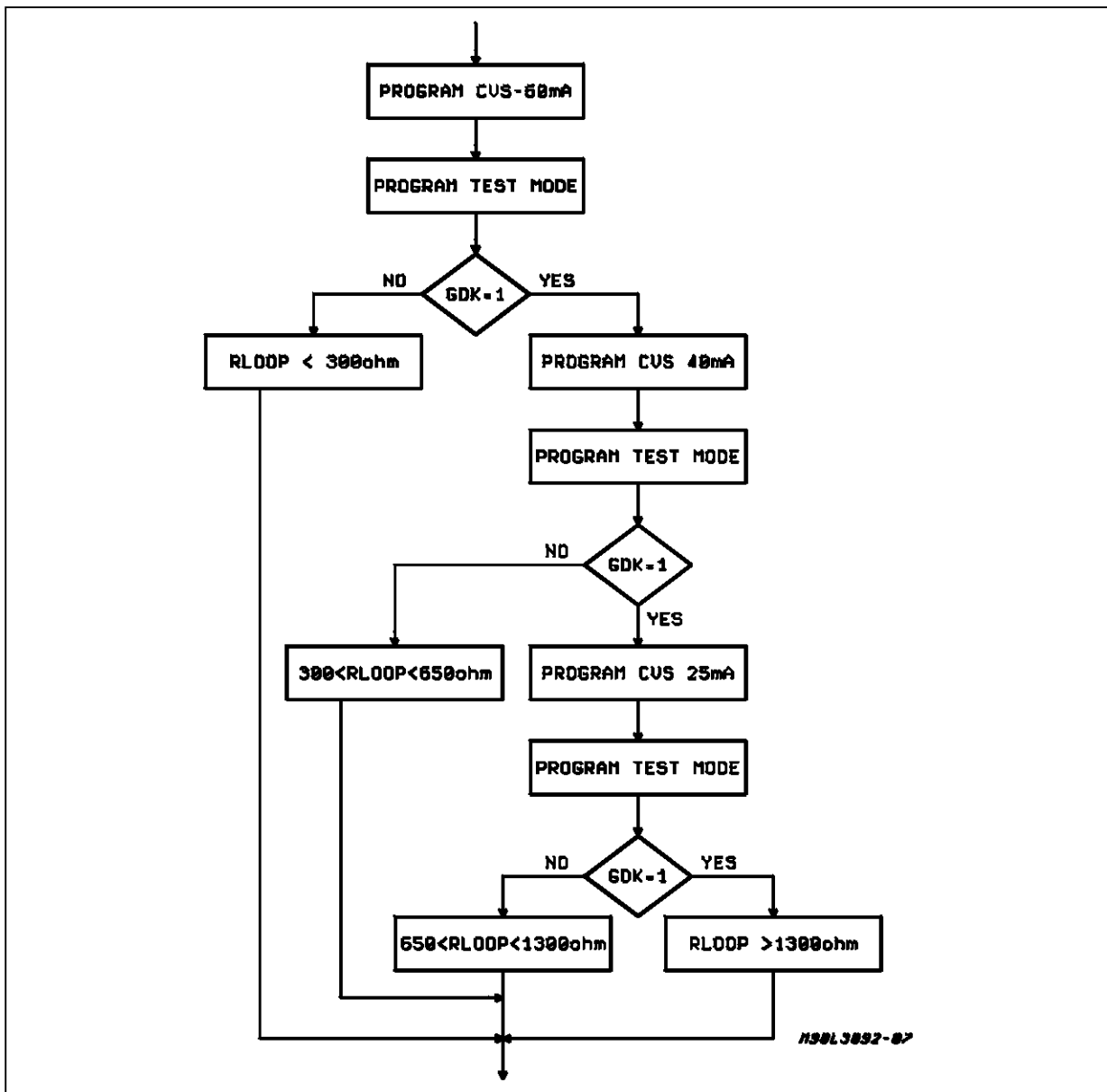

L3000N - L3092

6) RINGING MODE

When the ringing function is selected by the control processor a low level signal (1.5Vrms) with a frequency in the range from 16 to 70Hz, permanently applied to the L3092 (pin RGIN), is amplified and injected in balanced mode into the line through the L3000N with a super imposed DC voltage of 24V typ.

This low level sinewave can be obtained also from COMBO connecting RGIN pin to RX COMBO output with a decoupling capacitor.

The first and the last ringing cycles are synchronized by the L3092 so that the ringing signal always starts and stops when the line voltage crosses zero.

When this mode is activated, the L3000N operates between the negative and the positive battery voltages typically - 48V and + 72V. The impedance to the line is just equal to the two external resistors (typ. 100Ω).

Ring trip detection is performed autonomously by the SLIC, without waiting for a command from the control processor, using a patented system which allows detection during a ringing burst ; when the off-hook condition is detected, the SLIC stops the ringing signal and forces the Conversation Mode.

In this condition, if CS = 0V, the output pin ONHK goes to 0V.

After the detection of the ONHK = 0, the Card Controller must set the SLIC in Conversation Mode to remove the internal latching of the

On/Off hook information.

CONTROL INTERFACE BETWEEN THE SLIC AND THE CARD CONTROLLER

The SLIC states and functions are controlled by microprocessor or interface latches of a second generation combo through seven wires that define a parallel digital interface.

The seven pins of the digital interface have the following functions :

- Chip select input (CS)
- Power on/off input (PWON)
- Ring enable input (RNG)
- Automatic SBY input (AUT)
- Limiting current input (LIM)
- On hook/Off hook detection output (ONHK)
- Ground Key detection output (GDK)

The four input pins PWON, RNG, AUT and LIM, set the status of the SLIC as shown in the following table.

The output pin ONHK is equals to 0V when the line is in OFF hook condition ($I_{line} > 7,5mA$) and is equal to + 5V when the line is in On hook condition ($I_{line} < 5,5mA$).

The output pin GDK monitors the ground key function when the SLIC is in Conversation (CVS) Mode and the DC operating region (limiting or resistive) in Test (TS) Mode. When the SLIC is in Conversation (CVS) Mode and I_{GDK} (longitudinal current) > 12mA, pin GDK is set to 0V ;

Operating Mode	Input Pin				Output Pin	
	RNG	PWON	AUT	LIM	ONHK	GDK
Conversation 25mA	0	1	1	X	1 on-hook 0 off-hook	1 Ground key not detected. 0 Ground key detected.
Conversation 40mA	0	1	0	1		
Conversation 60mA	0	1	0	0		
Stand-by	0	0	0	X	C1 Comparator Output	Disable
Automatic Stand-by	1	0	1	X		
Power-down	1	0	0	X	1 on-hook 0 off-hook	Disable
Test Mode	0	0	1	X		0 Limiting Region
Ringing (CVS 25mA)	1	1	1	X		1 Resistive Region
Ringing (CVS 40mA)	1	1	0	1	0 off-hook	Disable
Ringing (CVS 60mA)	1	1	0	0		

N.B. : When Ringing Mode is selected, you must choose also which of the three possible Conversation Modes. The SLIC will automatically select if Off-Hook condition will be detected during ringing.

When $I_{GDK} < 8mA$, pin GDK set to + 5V

The longitudinal current (I_{GDK}) is defined as follows :

$$I_{GDK} = \frac{I_b - I_a}{2}$$

Where I_a is the current sourced from pin TIP and I_b is the current sunk into pin RING.

The CS input pin allows to connect the I/O pins of the digital interfaces of many SLIC together.

It is possible to do it because :

When the CS = + 5V the output pins (ONHK, GDK) are in high impedance condition ($> 100K\Omega$). The signals present at the input pins are not transferred into the SLIC.

When the CS = 0V the output pins change in function of the values of the line current (I_{line}) and the longitudinal current (I_{GDK}). The operating status of the SLIC are set by the voltage applied to the input pins.

The rising edge of the CS signal latches the signal applied to the input pins. The status of the SLIC will not change until the CS signal will be again equal to zero.

See timings fig 7 & 8.

An additional input pin MR (Master Reset) can be useful during the system start up phase or in emergency condition.

In fact when this pin is set to "0" the SLIC will be set in POWER DOWN MODE. This pin has an internal pull-up resistor of about $200K\Omega$

EXTERNAL COMPONENTS LIST

To set up the SLIC kit into operation, the following parameters have to be defined :

- The DC feeding resistance RFS, defined as the resistance of each side of the traditional feeding system (most common value for RFS are 200, 400 or 500).
- The AC input/output SLIC impedance at line terminals, ZML, to which the return loss measurement is referred. It can be real (typically 600Ω) or complex.
- The equivalent AC impedance of the line Zline used for evaluation of the trans-hybrid loss (2/4 wire conversion). It is usually a complex impedance.
- The frequency of the ringing signal Fr (SLIC can work with this frequency ranging from 16 to 68Hz).
- The value of the two resistors RP in series with the line terminals ; main purpose of the a.m. resistors is to allow primary protection to fire..

With these assumptions the following components list is defined :

Figure 7: Typical Application Circuit

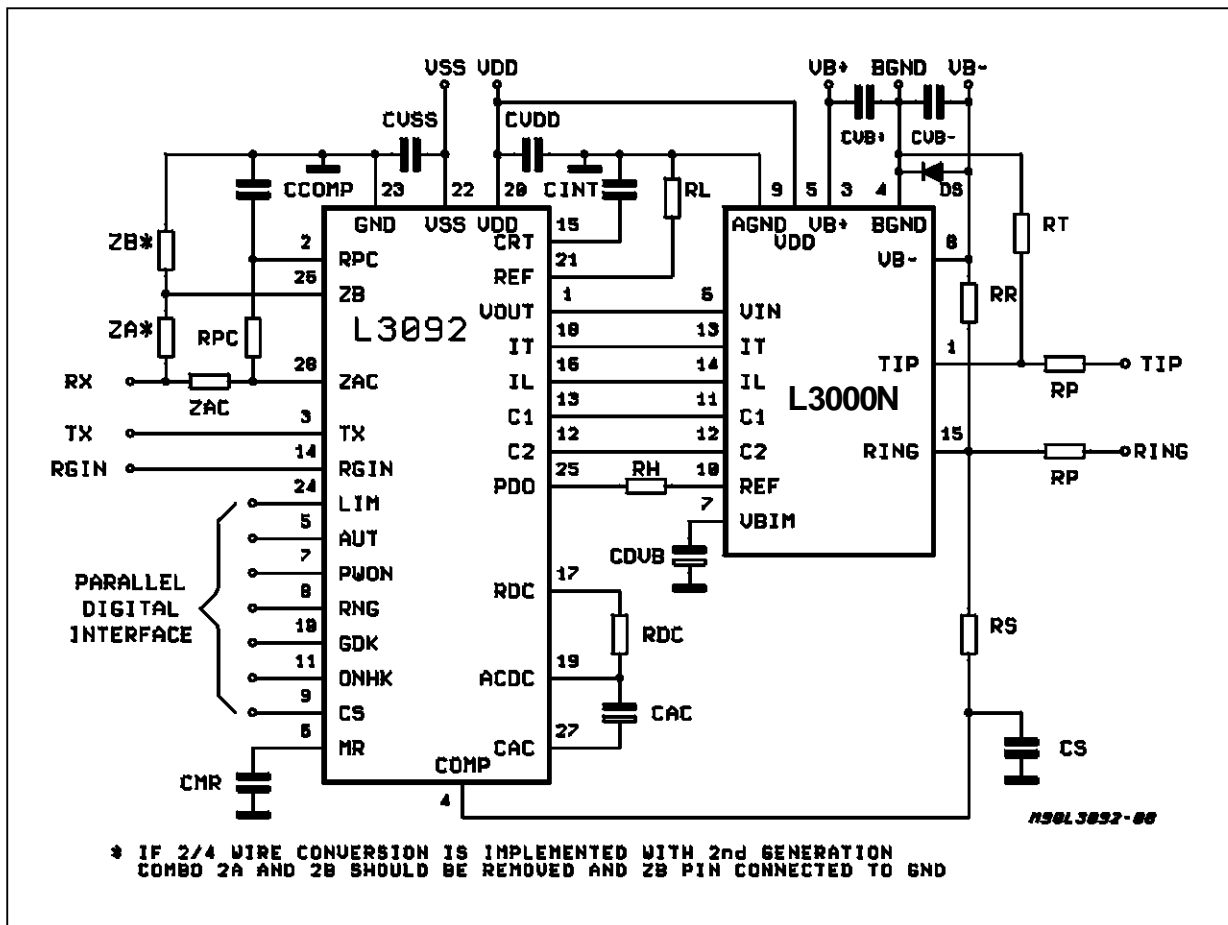

L3000N - L3092

EXTERNAL COMPONENT LIST FOR THE L3000N

Component		Involved Parameter or Function
Ref	Value	
RH	22.5K Ω \pm 2%	Bias Resistor
RP	30 to 100 Ω	Lines Series Resistor
CDVB	47 μ F - 20V \pm 20%	Battery Voltage Rejection
CVB+	0.1 μ F - 100V \pm 20%	Positive Battery Filter
CVB-	0.1 μ F - 100V \pm 20% (note 1)	Negative Battery Filter
DS	BAT49X (note 2)	Protective Shottky Diode

EXTERNAL COMPONENT LIST FOR THE L3092

CVSS	0.1 μ F - 15V	Negative Supply Voltage Filter
CVDD	0.1 μ F - 15V	Positive Supply Voltage Filter
CAC	47 μ F - 10V \pm 20%	AC Path Decoupling
ZAC	25 x (ZML - 2xRP)	2 Wire AC Impedance
CCOMP	$\frac{1}{2\pi f_0 (50 R_P)}$ with $f_0 = 200\text{KHz}$	AC Loop Compensation
RPC	25 x (2xRP)	R _P Insertion Loss Compensation
RDC	2 x (RFS - RP)	DC Feeding Resistor (RDC > 200 Ω)
RL	63.4K Ω \pm 1%	Bias Resistor
ZA	K x Z _{ML} (note 3)	SLIC Impedance Balancing Network
ZB	$(K \times Z_{\text{line}}) // (\frac{25}{K} \times \text{CCOMP})$ (note 4)	Line Impedance Balancing Network
CINT	see Table 2 (note 5)	Ring Trip Detection Time Constant
RT	47K Ω	Resistors used only in the automatic stand-by mode.
RR	47K Ω	
RS	1.5M Ω (note 6)	
CS	47nF	To be used only if high common mode rejection in Aut. SBY mode and in Power Down mode is requested (note 7)
CMR	100nF	To be used only if Power on reset requested. The capacitor value depends on V _{DD} rise time.

Notes:

- In case line cards with less than 7 subscribers are implemented CVB- capacitor should be equal to 680nF/N where N is the number of subscriber per card.
- This shottky diode or equivalent is necessary to avoid damage to the device during hot insertion or in all those cases when a proper power up sequence cannot be guaranteed. In case the Shottky diode is not implemented the power sequence should guarantee that VB+ is always the last supply applied at power on and the first removed at power off.
In case an other shottky diode type is adopted it must fulfill the following characteristics:
V_F < 450mV @ I_F = n · 15mA, T_{amb} = 25°C
V_F < 350mV @ I_F = n · 15mA, T_{amb} = 50°C (T_{JL3000} = 90°C)
V_F < 245mV @ I_F = n · 15mA, T_{amb} = 85°C (T_{JL3000} = 120°C)
Where n is the number of line sharing the same diode.
- The structure of this network shall copy the SLIC output impedance multiplexed by a factor K = 10 to 25. This network must be removed when 2/4 wire conversion is implemented with 2nd generation COMBO (EG. TS5070).
- The structure of this network shall copy the line impedance, Z_{line}, multiplexed by a factor K = 10 to 25 and compensate the effect of CCOMP on transhybrid rejection. This network must be removed when 2/4 wire conversion is implemented with 2nd generation COMBO (EG. TS5070).
- The CINT value depends on the ringing frequency F_R.
- Value related to V_b = 48V application, for application with different battery voltages should be properly dimensioned (see Fig.4).
- Ex.: For line leakage resistance to GND equal to 500K Ω , the common mode rejection is 5V_P without CS and about 10V_P with CS -

Table 2

Fr (Hz)	16/18	19/21	22/27	28/32	33/38	39/46	47/55	56/68
CINT (nF)	680	580	470	390	330	270	220	180

The CINT value can be optimized experimentally for each application choosing the lower value that in correspondance of the lower ringing frequency,

the minimum line length and the higher number of ringers doesn't produce false off-hook detection.

ELECTRICAL CHARACTERISTICS ($V_{DD} = +5V$; $V_{SS} = -5V$; $V_{B+} = +72V$; $V_{B-} = -48V$; $T_{amb} = +25^{\circ}C$ ⁽¹⁾)
 STANDBY

Symbol	Parameter	Test Conditions	Min.	Typ.	Max.	Unit
V_{LS}	Output Voltage at L3000N Terminals	I Line = 0mA		43		V
I_{LCC}	Short Circuit Current		8.8		12.5	mA
lot	Off-hook Detection Threshold		5.3		8.8	mA
Hys	Off-hook/on-hook Hysteresis		1.5		2.5	mA
Vls	Simmetry to Ground				.75	V

CONVERSATION

Symbol	Parameter	Test Conditions	Min.	Typ.	Max.	Unit
V_{LO}	Output Voltage at L3000N Terminals	I Line = 0mA		43		V
Ilim	Current Programmed Through the LIM and AUT Inputs		Ilim -10%		Ilim +10%	mA
lot	Off-hook Detection Threshold		5.6		9.8	mA
Hys	Off-hook/on-hook Hysteresis		1.5		2.5	mA
Ilgk	Longitudinal Line Current with GDK Detect		6.5		15	mA

POWER-DOWN

Symbol	Parameter	Test Conditions	Min.	Typ.	Max.	Unit
V_{CN}	Input Voltage at Pin COMP to Set the Output Pin ONHK = 1				-100	mV
V_{CF}	Input Voltage at Pin COMP to Set the Output Pin ONHK = 0		100			mV
I_{COM}	Output Current at Pin COMP	COMP = GND		20		μ A

SUPPLY CURRENT

Symbol	Parameter	Test Conditions	Min.	Typ.	Max.	Unit
I_{DD}	Positive Supply Current CS = 1	Power Down/aut.		5.7		mA
		Stand-by		7.5		mA
		Conversation		11.7		mA
		Ringing		11.3		mA
I_{SS}	Negative Supply Current CS = 1	Power Down/aut.		4.2		mA
		Stand-by		4.2		mA
		Conversation		8.2		mA
		Ringing		8.2		mA
I_{BAT-}	Negative Battery Supply Current Line Current = 0mA	Power Down/aut.		0		mA
		Stand-by		2	2.5	mA
		Conversation		5	6.5	mA
		Ringing		14	17	mA
I_{BAT+}	Positive Battery Supply Current Line Current = 0mA	Power Down/aut.		0		μ A
		Stand-by		10	15	μ A
		Conversation		10	15	μ A
		Ringing		12	13.5	mA

L3000N - L3092

AC OPERATION

Symbol	Parameter	Test Conditions	Min.	Typ.	Max.	Unit
Zlx	Sending Output Impedance on TX				15	Ω
THD	Signal Distortion at 2W and 4W Terminals	Vtx = 0dBm @ 1020Hz			0.3	%
RI	2W Return Loss	f = 300 to 3400Hz	22			dB
Thl	Transhybrid Loss	f = 300 to 3400Hz $20\log_{10} \left \frac{V_R}{V_S} \right $	30			dB
Gs	Sending Gain ⁽²⁾	Vso = 0dBm; f = 1020Hz	-6.27	-6.02	-5.77	dB
Gsf	Sending Gain Flatness vs. Frequency	f = 300 to 3400Hz Respect to 1020Hz	-0.1		+0.1	dB
GI	Sending Gain Linearity	fr = 1020Hz Vsoref = -10dBm Vso = +4 / -40dBm	-0.1		+0.1	dB
Gr	Receiving Gain	Vrl = 0dBm; f = 1020Hz	-0.25		+0.25	dB
Grf	Receiving Gain Flatness	f = 300 to 3400Hz Respect to 1020Hz	-0.1		+0.1	dB
Grf	Receiving Gain Linearity	fr = 1020Hz Vrlref = -10dBm Vrl = +4 / -40dBm	-0.1		+0.1	dB
Np4W	Psophomet. Noise 4W - Tx Terminals			-79	-74	dBmp
Np4W	Psophomet. at Line Terminals			-75	-70	dBmp
SVRR	Supply Voltage Rejection Ratio Relative to VB-	f = 10Hz Vn = 100mVrms		-20		dB
		f = 1KHz Vn = 100mVrms			-35	dB
		f = 3.4KHz Vn = 100mVrms			-30	dB
Ltc	Longitudinal to Transversal Conversion	f = 300 to 3400Hz I line = 30mA ZML = 600 Ω				
Tlc	Transversal to Longitudinal Conversion		48	51		dB

Notes:

(*) 52dB using selected L3000N

(1) The datasheet certifies the electrical characteristics at 25°C. For applications requiring operations in the standard temperature range (0°C to 70°C) use L3000N/L3092. If operations are required in the extended temperature range (-40°C to +85°C), use the kit L3000NT/L3092T.

(2) value optimized for programmable COMBO Hybrid Balance Filter

RINGING PHASE

Symbol	Parameter	Test Conditions	Min.	Typ.	Max.	Unit
Vir	Superimposed DC Voltage	Rloop > 100K Ω	19		27	V
		Rloop = 1K Ω	17		25	V
Vacr	Ringing Signal at Line Terminal	Rloop > 100k Ω V _{RGN} = 1.5Vrms/30Hz	56.0			Vrms
		Rloop = 1K Ω + 1 μ F V _{RGN} = 1.5Vrms/30Hz	56.0			Vrms
If	DC Off-hook Del Threshold			5.5		mA
Ilim	Output Current Capability		85		130	mA
Vrs	Ringing Symmetry				2	Vrms
THDr	Ringing Signal Distortion				5	%
Zir	Ringing Amplit. Input Impedance	L3092's Pin RGIN	50			K Ω
Vrr	Residual of Ringing Signal at Tx Output				100	mVrms
Trt	Ring Trip Detection Time	fring = 25Hz (T = 1/fring) CINT = 470nF		80(3T)		ms
Toh	Off-hook Status Delay after the Ringing Stop				50	μ s

DIGITAL INTERFACE ELECTRICAL CHARACTERISTICS

(V_{DD} = +5V; V_{SS} = -5V; T_{amb} = 25°C ⁽¹⁾)

STATIC ELECTRICAL CHARACTERISTICS

Symbol	Parameter	Test Conditions	Min.	Typ.	Max.	Unit
Vil	Input Voltage at Logical "0"	Pins CS PWON LIM	0		0.8	V
Vih	Input Voltage at Logical "1"		2		5	V
Vil	Input Voltage at Logical "0"	Pins RNG-AUT	0		0.5	V
Vih	Input Voltage at Logical "1"		2.3		5	V
Iil	Input Current at Logical "0"	All logic pins Vil = 0V Vih = 5V			15	μ A
Iih	Input Current at Logical "1"				25	μ A
Vol	Output Voltage at Logical "0"	Pins ONHK GDK I _{out} = -1mA I _{out} = 1mA			0.4	V
Voh	Output Voltage at Logical "1"		2.4			V
Iik	Tristate Leak Current	CS = "1"			10	μ A
I _{MR}	Pull-up MR Output Current	MR = "0"		50		μ A

DYNAMIC ELECTRICAL CHARACTERISTICS

Symbol	Parameter	Test Conditions	Min.	Typ.	Max.	Unit
Tsd	PWON, RING, AUT, LIM		1500			ns
Thd	PWON, RING, AUT, LIM		0			ns
Tww	CS Impulse Width (writing op.)		1500			ns
Thv	ONHK, GDK Data Out to "0" CS Delay				600	ns
Tvh	ONHK, GDK High Imped. to "1" CS Delay				600	ns
Twr	CS Impulse Width (writing op.)		800			ns

(1) The datasheet certifies the electrical characteristics at 25°C. For applications requiring operations in the standard temperature range (0°C to 70°C) use L3000N/L3092. If operations are required in the extended temperature range (-40°C to +85°C), use the kit L3000NT/L3092T.

Figure 8: Writing Operating Timing (controller to SLIC).

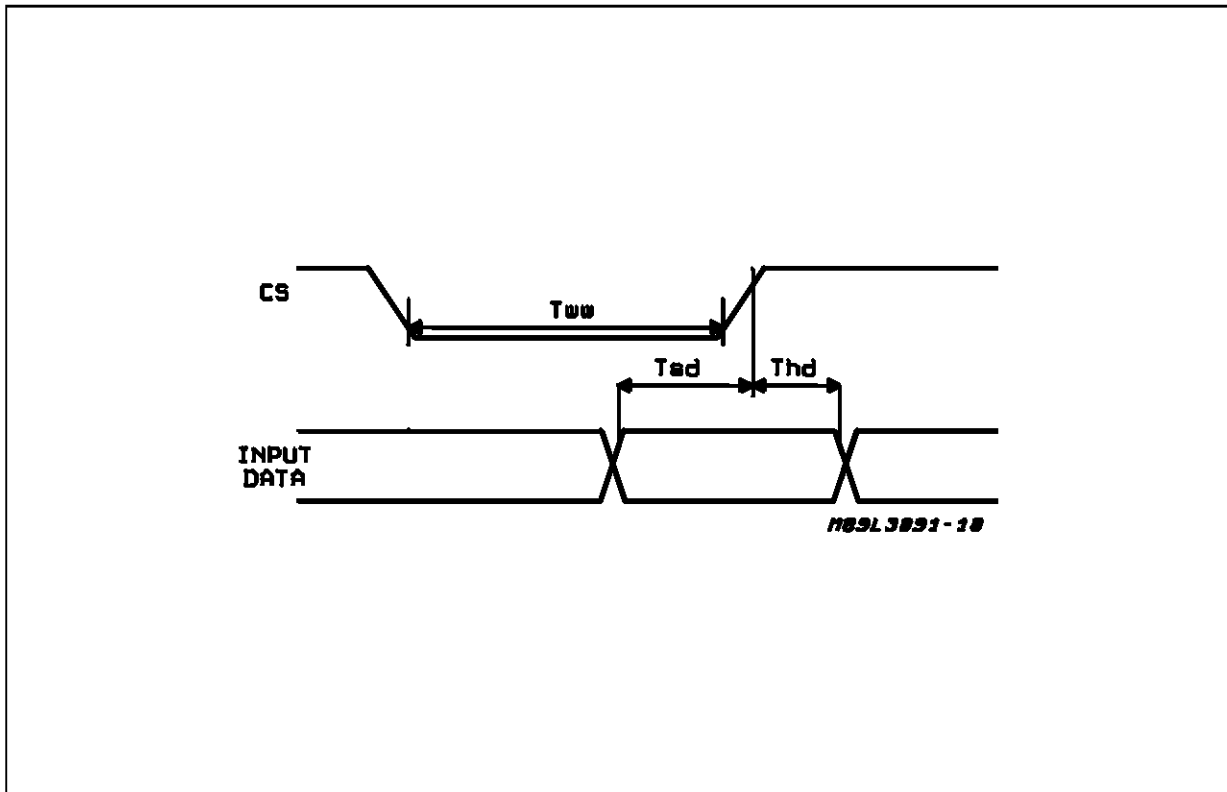

Figure 9: Reading Operating Timing (from SLIC to controller).

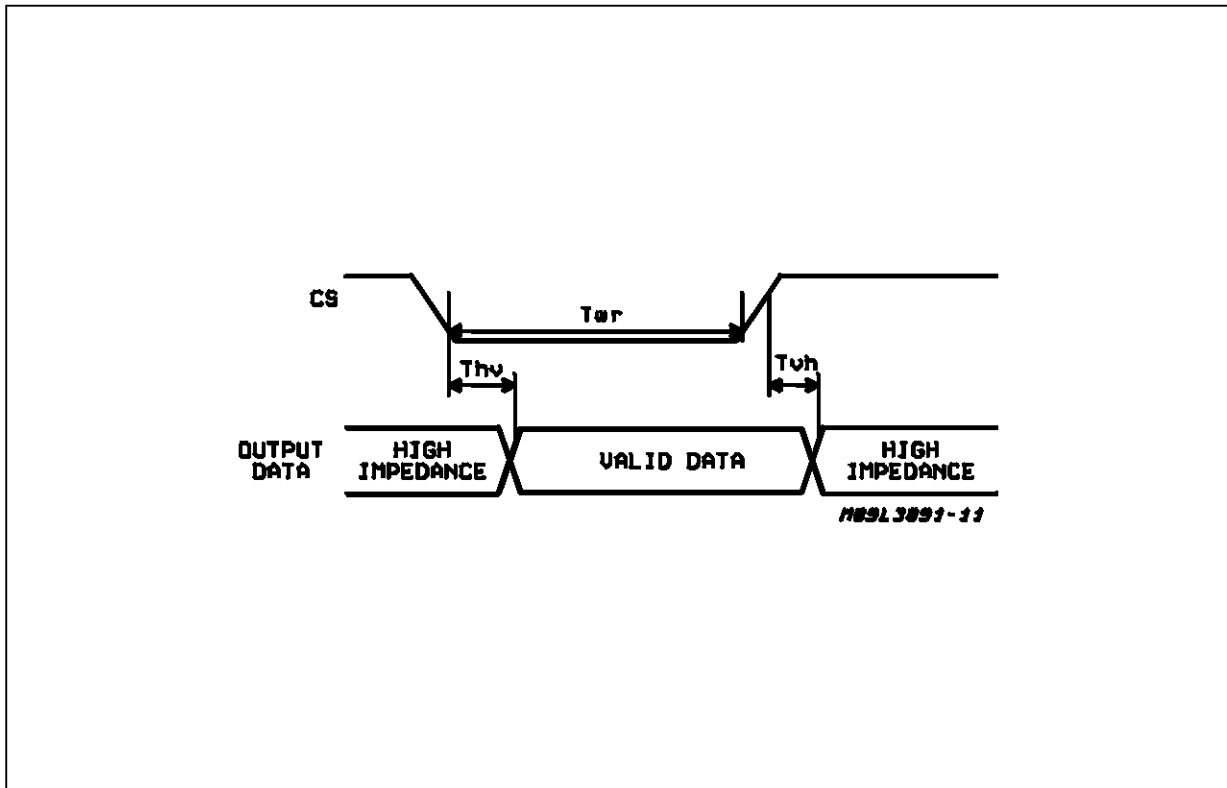
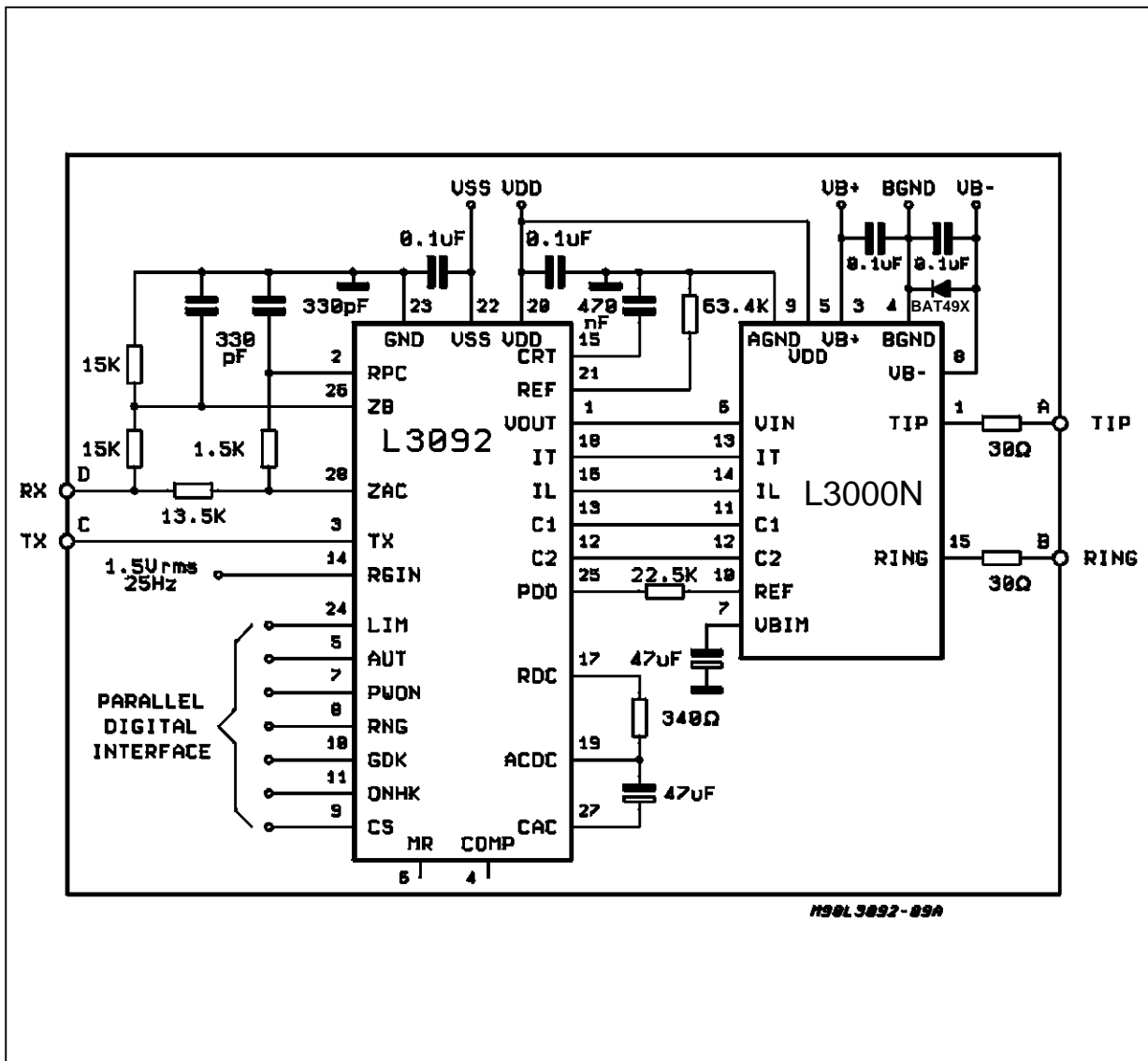

Figure 10: Test Circuit



A, B, C, D are test reference points used during testing.

Figure 11: Typical Application Circuit with 2nd Generation COMBO for Complete Subscriber Circuit (Protection - SLIC - COMBO).

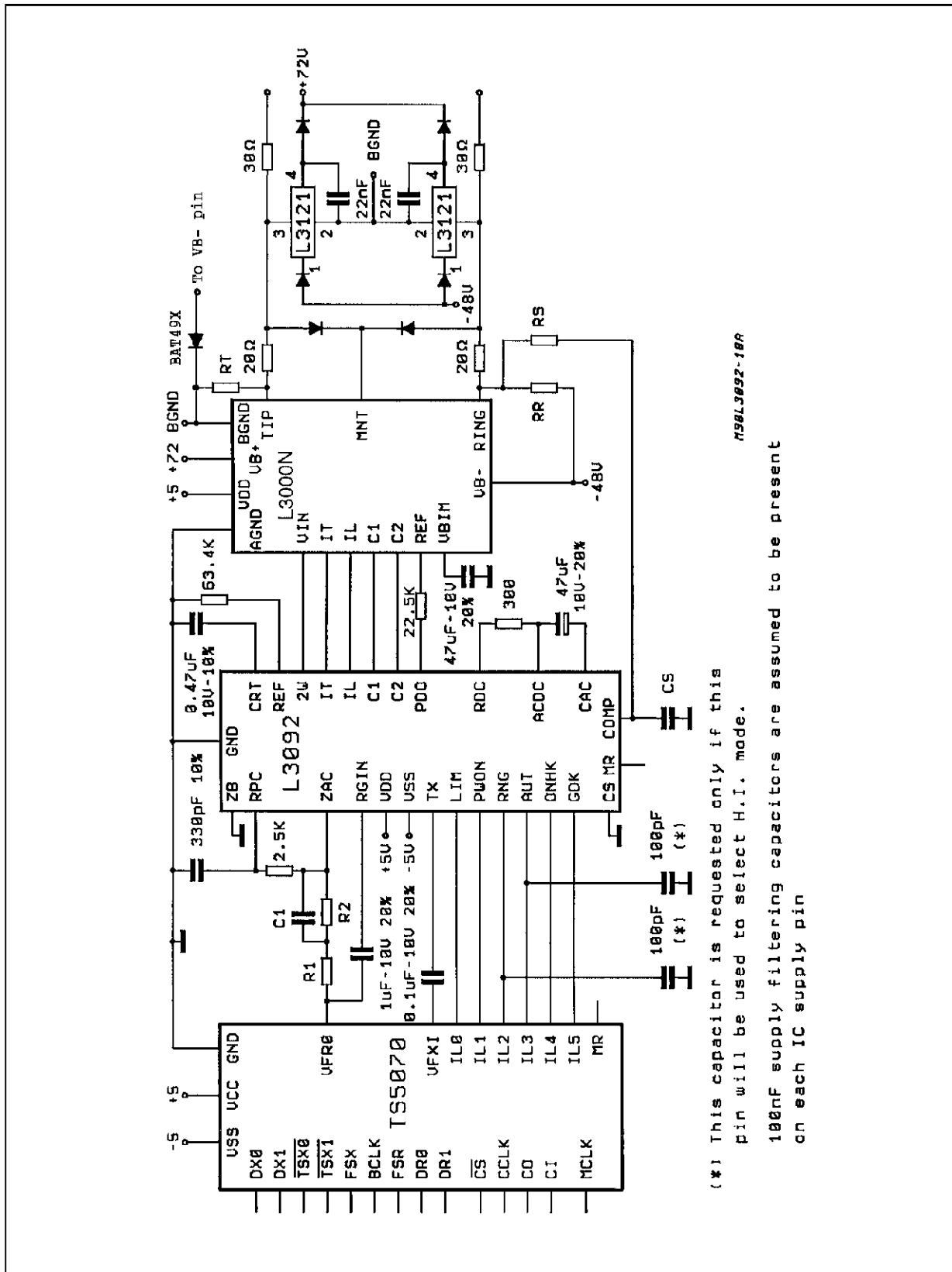
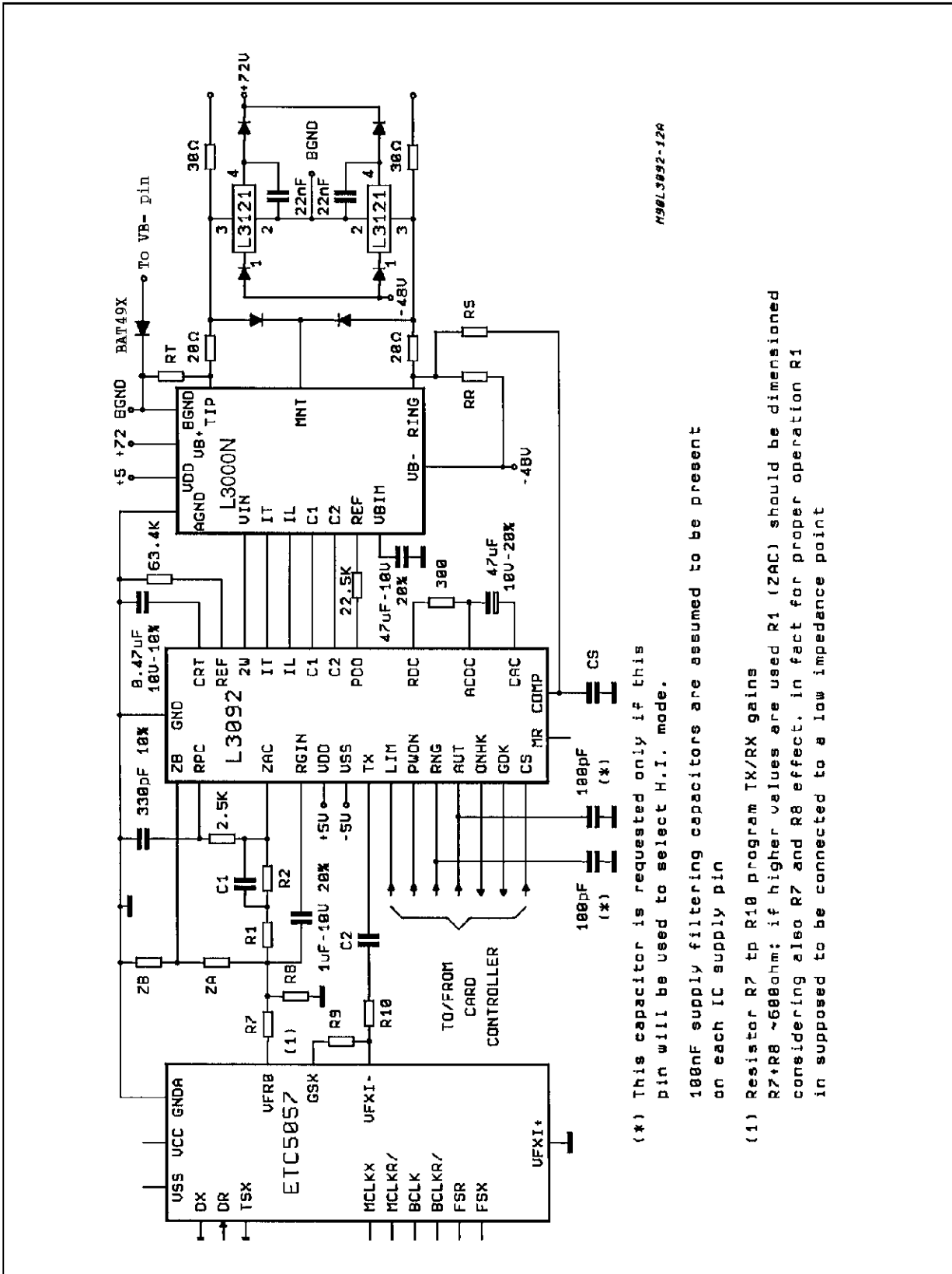

Figure 12: Typical Application Circuit with 1st Generation COMBO for Complete Subscriber Circuit (Protection - SLIC - COMBO).



APPENDIX A

SLIC TEST CIRCUITS

Referring to the test circuit reported at the end of each SLIC data sheet here below you can find the proper configuration for each measurement.

In particular:

A-B: Line terminals

C: Tx sending output on 4W side

D: Rx receiving input on 4W Side

E: TTx teletaxe signal input

R_{GIN}: low level ringing signal input.

TEST CIRCUITS

Figure A1: Symmetry to Ground

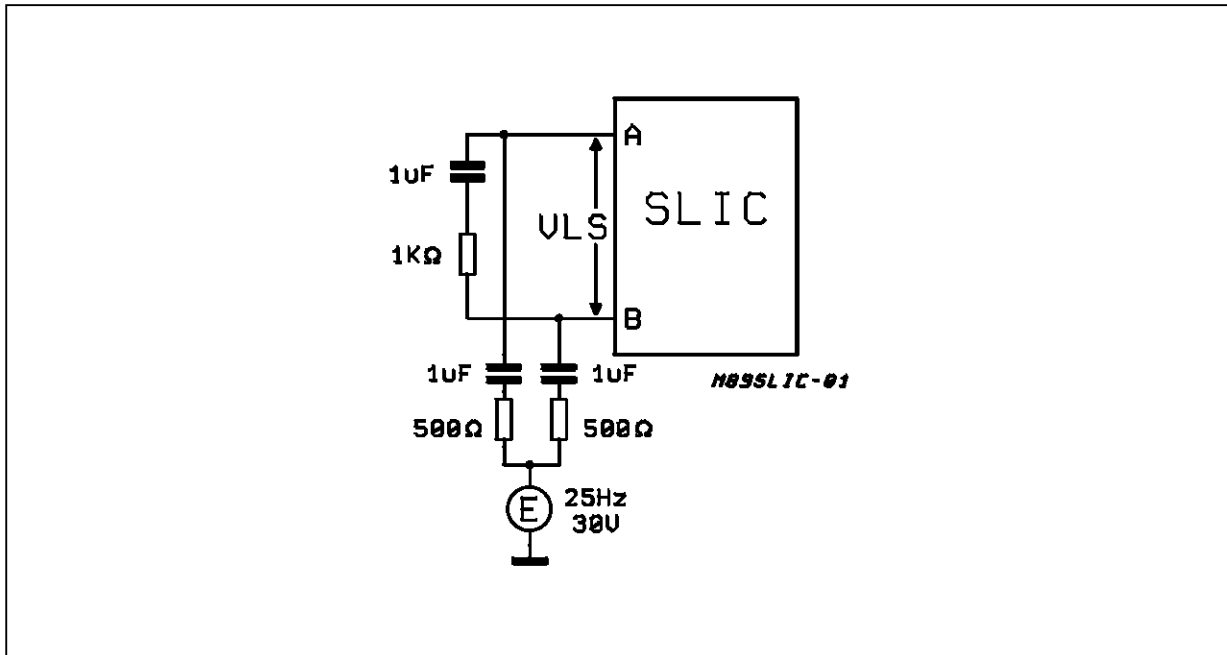
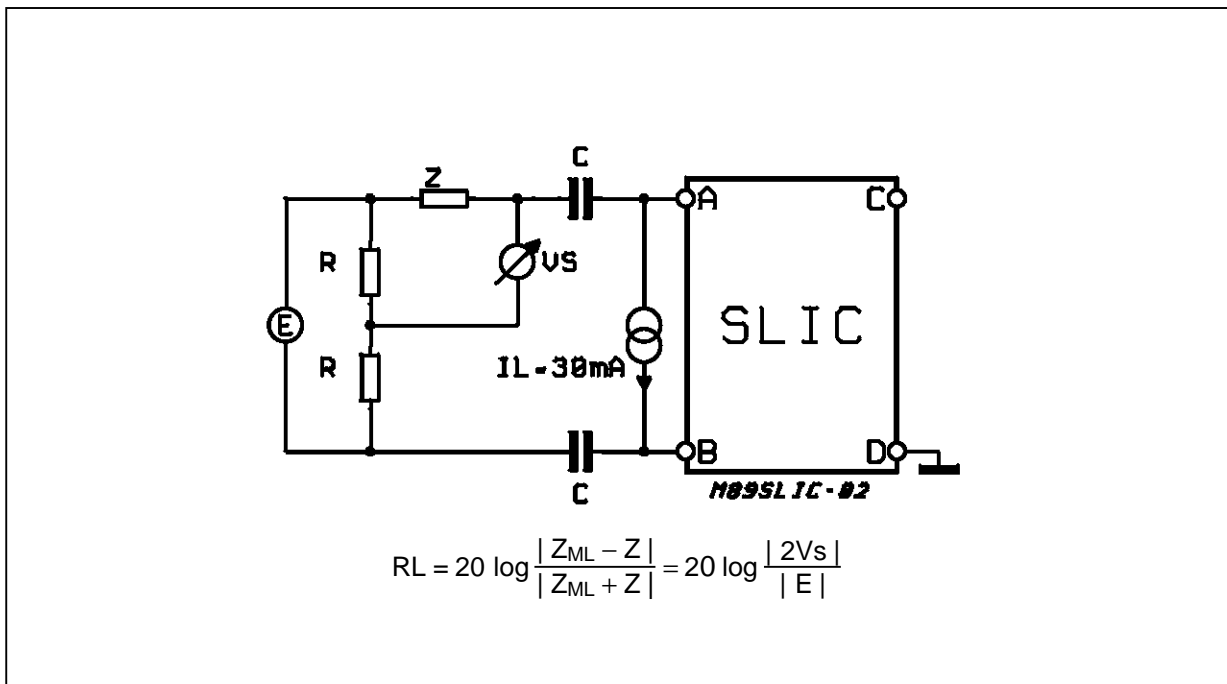

Figure A2: 2W Returns Loss



TEST CIRCUITS (continued)

Figure A3: Trans-hybrid Loss.

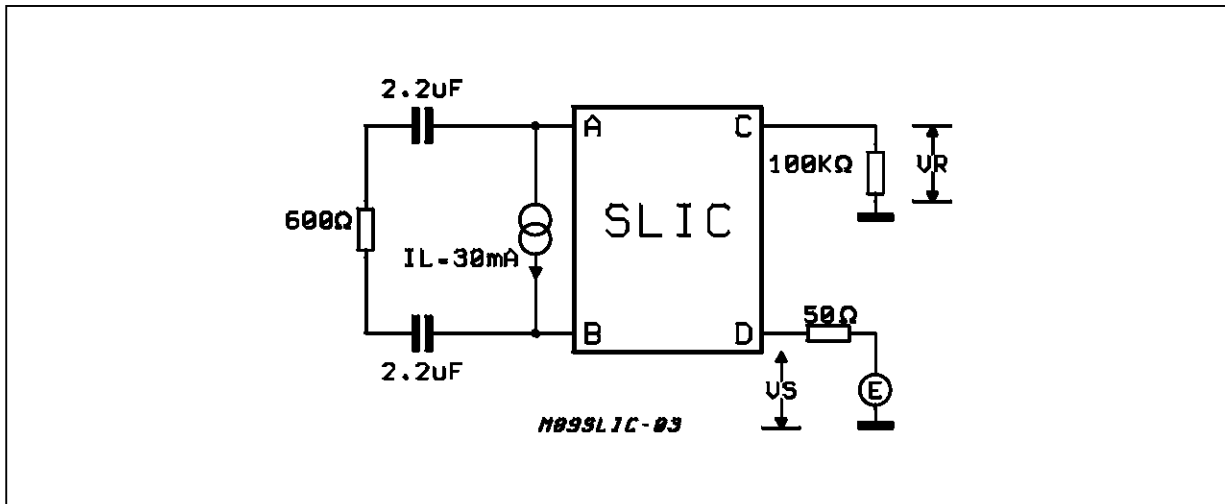

Figure A4: Sending Gain

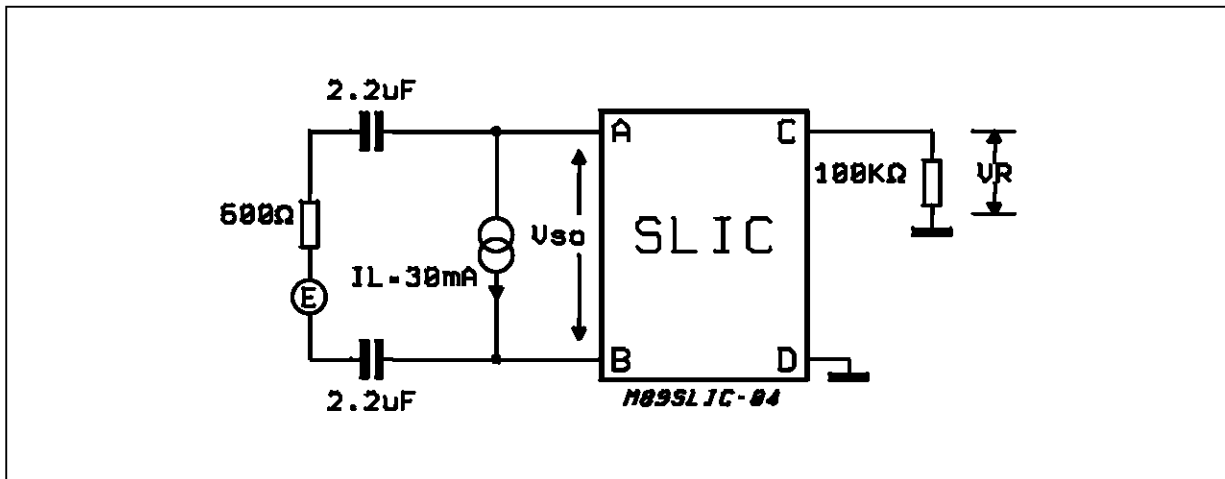
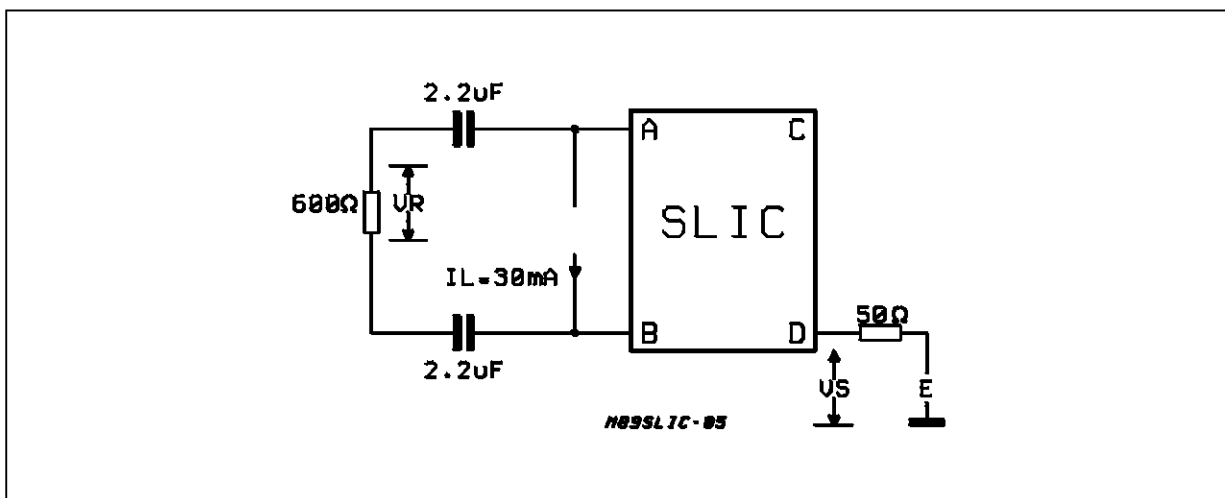

Figure A5: Receiving Gain



TEST CIRCUITS (continued)

Figure A6: PSRR Relative to Battery Voltage V_B -

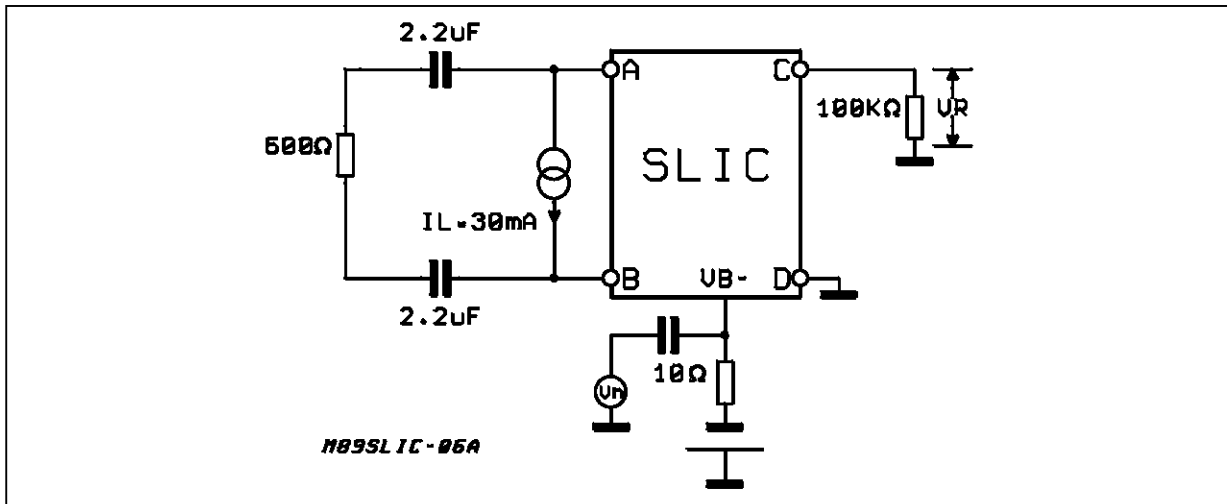

Figure A7: Longitudinalto Transversal Conversion

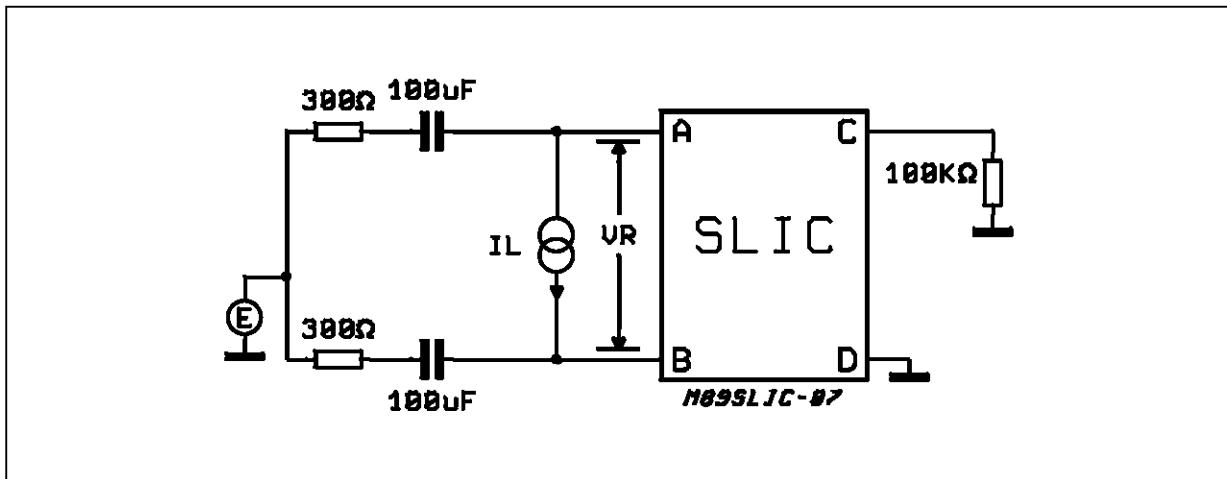
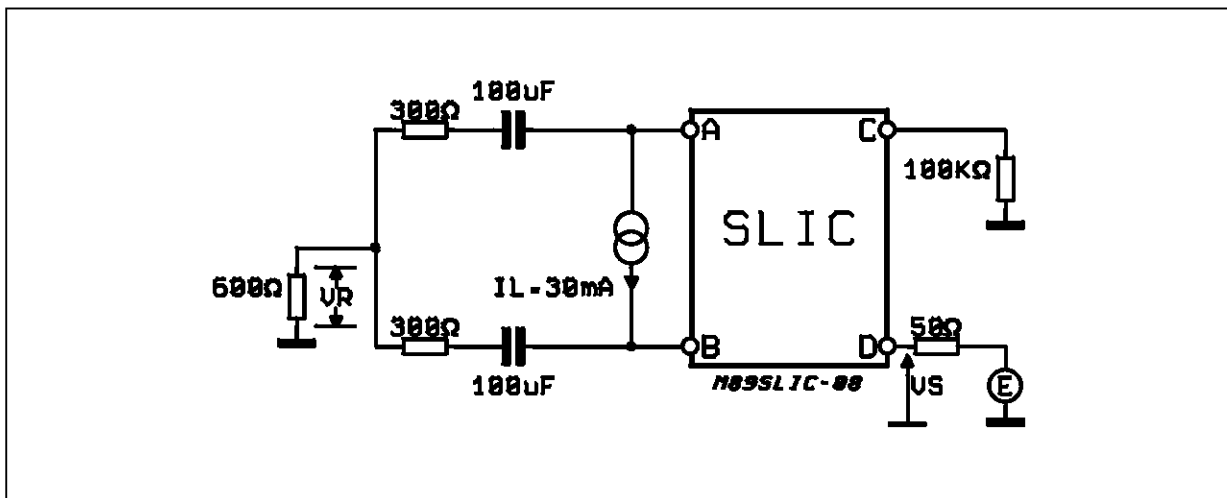

Figure A8: Longitudinalto Transversal Conversion



TEST CIRCUITS (continued)

Figure A9: TTX Level at Line Terminals

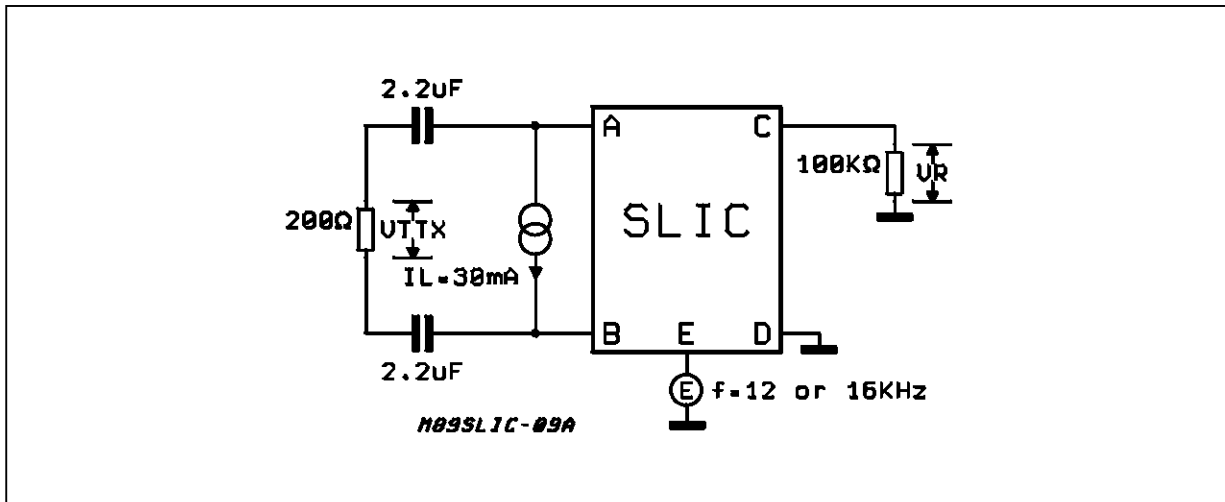
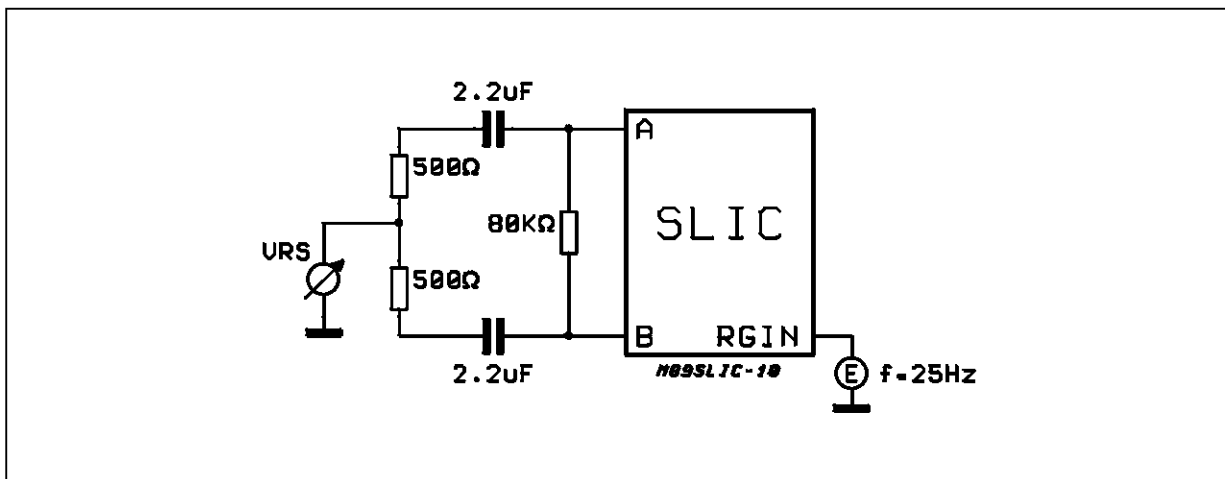

Figure A10: Ringing Symmetry



APPENDIX B

ADDITIONAL OPERATING FEATURES

Two further operating modes are provided on the L3092, boosted battery and ring pause. Both of these Modes are accessed by applying a high impedance on inputs AUT and or RING of the digital interface.

1. Boosted Battery (BB)

This operating mode is equivalent to conversation mode with respect to AC and signaling functions but with the following changes to the DC characteristics:

- a) Current limiting value fixed at 25mA.
- b) Characteristic in the resistive feeding region corresponds to a battery voltage equal to $(-5 + |V_B| + V_{B+})$ Volt in series with the same feeding resistor utilized in the DC characteristic of conversation mode.

BB mode is typically used to feed long lines (20mA/4Kohm) and to implement special functions such as message waiting where high voltage signals are required.

Further information about this operating mode may be found by referring to the L3000/L3030 datasheet.

2. Ringing Pause Mode

During Ring Pause - Mode the SLIC is always in ringing mode but the AC ringing signal is not injected into the line. This mode allows to avoid any common mode voltage variation of TIP and RING wire during the transition between Ringing Burst and Ringing Pause. This feature is used in application where it is mandatory to avoid perturbations on adjacent lines during ringing injection. For example when in the same system analog lines are used both for speech and modem transmission.

The following table shows all operating modes of L3000/L3092 SLIC KIT. Boosted Battery or Ringing Pause Modes are selected by applying a high impedance (HI) to input pins RNG and/or AUT.

Included also in this table are the operating modes to which the SLIC defaults automatically during ringing mode when OFF HOOK is detected.

CONTROL INTERFACE BETWEEN THE SLIC AND THE CARD CONTROLLER

Operating Mode	Input Pin				Output Pin	
	RNG	PWON	AUT	LIM	ONHK	GDK
Conversation 25mA	0	1	1	X	1 on-hook 0 off-hook	1 Ground key not detected 0 Ground key detected
Conversation 40mA	0	1	0	1		
Conversation 60mA	0	1	0	0		
Boosted Battery 25mA	0	1	HI	X		
Stand-by	0	0	0	X		
Automatic Stand-by	1	0	1	X	C1 Comparator Output	Disable
Power Down	1	0	0	X		
Test Mode	0	0	1	X	1 on-hook 0 off-hook	0 Limiting Region 1 Resistive Region
Ringing Inj. (CVS 25mA)	1	1	1	x		
Ringing Inj. (CVS 40mA)	1	1	0	1		
Ringing Inj. (CVS 60mA)	1	1	0	0		
Ringing Inj. (BB 25mA)	1	1	HI	X		
Ringing Pause (CVS 25mA)	HI	1	1	X	1 on-hook 0 off-hook	Disable
Ringing Pause (CVS 40mA)	HI	1	0	1		
Ringing Pause (CVS 60mA)	HI	1	0	0		
Ringing Pause (BB 25mA)	HI	1	HI	X		
Ringing Pause (BB 25mA)	HI	1	HI	X		

NB:
 HI = High Impedance
 BB = Boosted Battery

APPENDIX C

LAYOUT SUGGESTIONS

Standard layout rules should be followed in order to get the best system performances:

- 1) Use always 100nF filtering capacitor close to the supply pins of each I.C.
- 2) Connect together BGND and AGND at a low impedance point. (e.g. on a ground

plane common to the line card).

- 3) The L3092 bias resistor (RL) should be connected close to the corresponding pins of L3092 (REF and GND).
Avoid any digital line to pass close to REF pin.
Eventually screen REF pin with a GND track.

PLCC28 PACKAGE MECHANICAL DATA

DIM.	mm			inch		
	MIN.	TYP.	MAX.	MIN.	TYP.	MAX.
A	12.32		12.57	0.485		0.495
B	11.43		11.58	0.450		0.456
D	4.2		4.57	0.165		0.180
D1	2.29		3.04	0.090		0.120
D2	0.51			0.020		
E	9.91		10.92	0.390		0.430
e		1.27			0.050	
e3		7.62			0.300	
F		0.46			0.018	
F1		0.71			0.028	
G			0.101			0.004
M		1.24			0.049	
M1		1.143			0.045	

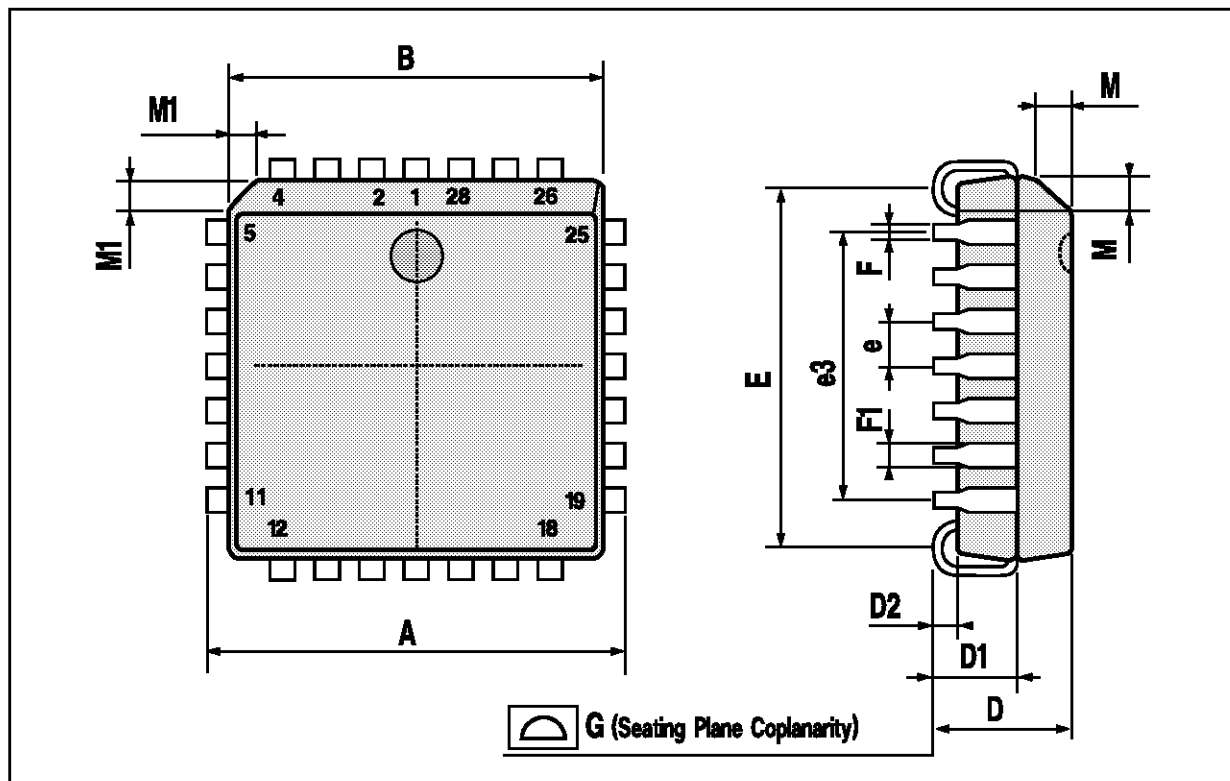

PowerSO-20(SLUG UP) PACKAGE MECHANICAL DATA

DIM.	mm			inch		
	MIN.	TYP.	MAX.	MIN.	TYP.	MAX.
A			3.70			0.145
a1	0		0.25	0		0.01
b	0.40		0.53	0.016		0.021
c	0.23		0.32	0.009		0.012
D	15.80		16.00	0.622		0.63
D1	9.4		9.80	0.37		0.385
E	13.90		14.50	0.547		0.57
e		1.27			0.05	
e3		11.43			0.45	
E1	10.90		11.10	0.429		0.437
E2			2.90			0.114
E3	5.80		6.20	0.228		0.244
G	0		0.10	0		0.004
h			1.10			0.043
L	0.80		1.10	0.031		0.043
N	10° (Max.)					
S	8° (Max.)					

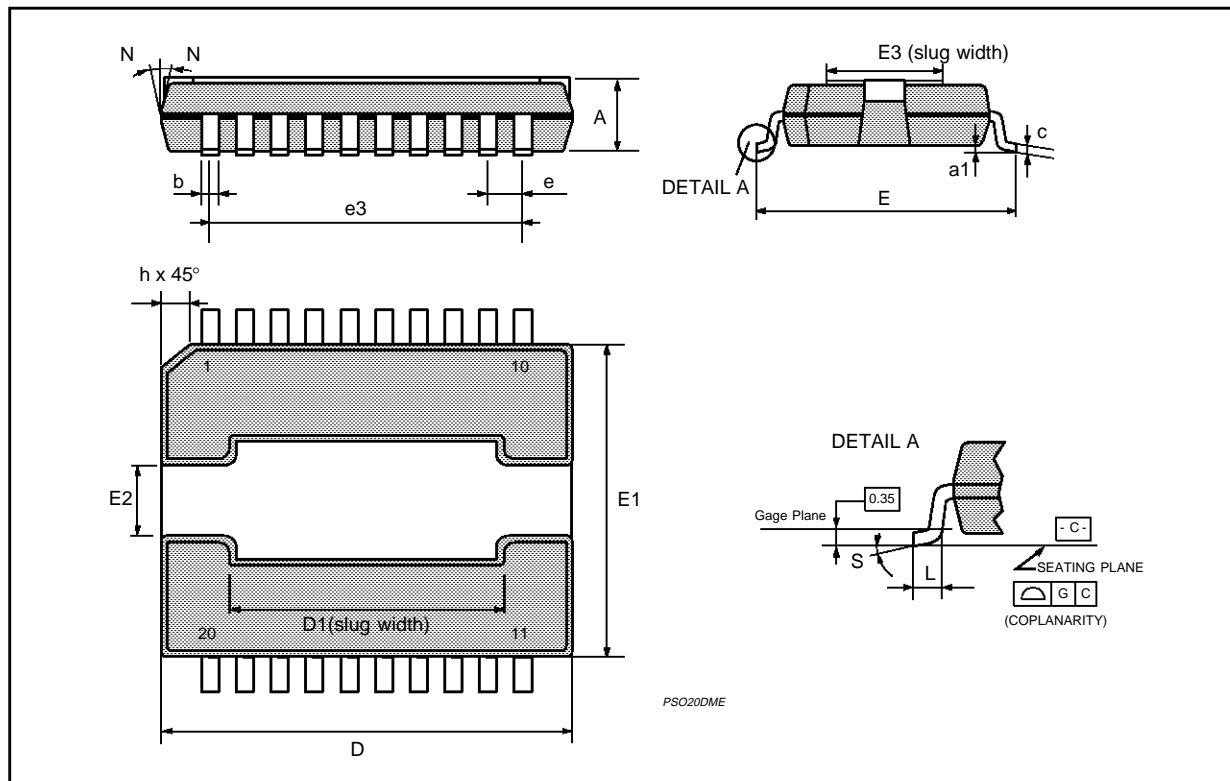

DIP28 PACKAGE MECHANICAL DATA

DIM.	mm			inch		
	MIN.	TYP.	MAX.	MIN.	TYP.	MAX.
a1		0.63			0.025	
b		0.45			0.018	
b1	0.23		0.31	0.009		0.012
b2		1.27			0.050	
D			37.34			1.470
E	15.2		16.68	0.598		0.657
e		2.54			0.100	
e3		33.02			1.300	
F			14.1			0.555
I		4.445			0.175	
L		3.3			0.130	

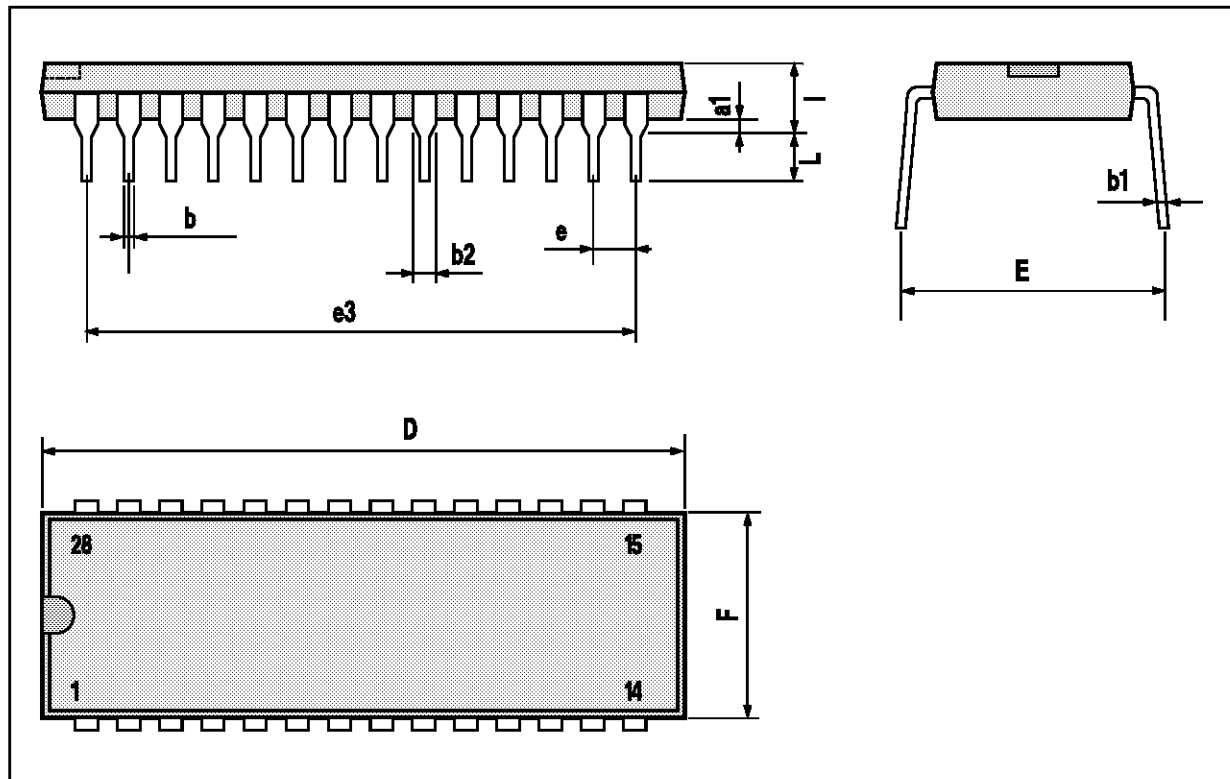

FLEXIWATT 15 PACKAGE MECHANICAL DATA

DIM.	mm			inch		
	MIN.	TYP.	MAX.	MIN.	TYP.	MAX.
A			5.00			0.196
B			1.90			0.074
b1			0.1			0.004
D	4° (typ.)					
E		0.30			0.012	
F		0.90			0.035	
F1			0.57			0.022
G	1.77	1.9	2.03	0.070	0.075	0.080
G1		26.77			1.054	
H1		29.00			1.142	
H2		28.00			1.102	
H3		17.00			0.669	
H4		0.80			0.031	
L	19.05		19.95	0.75		0.785
L1	1.10		1.40	0.043		0.055
L2	2.60		2.90	0.102		0.114
L3	15.35		15.65	0.604		0.616
N1		10			0.394	
N3		6.8			0.268	
N4		3.8			0.15	
Dia1		13.00			0.511	
Dia2		14.00			0.551	
Dia3		2.50			0.098	
Dia4		12.00			0.472	

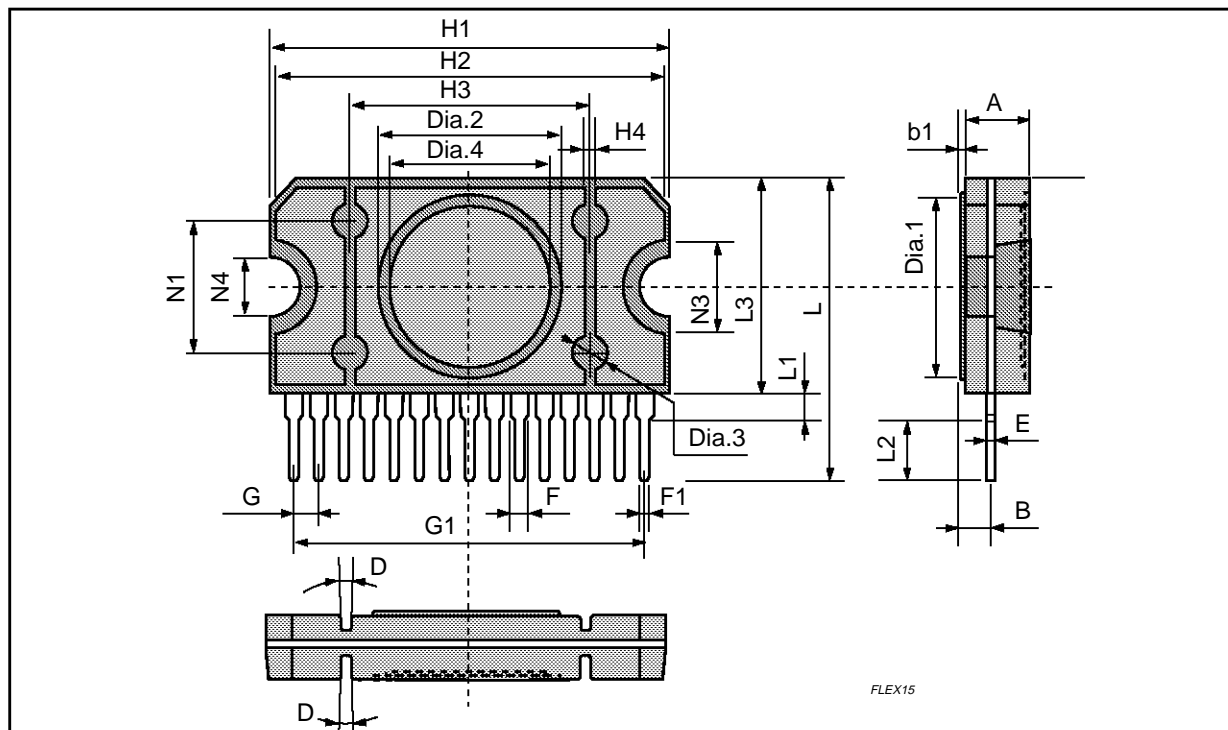

Information furnished is believed to be accurate and reliable. However, SGS-THOMSON Microelectronics assumes no responsibility for the consequences of use of such information nor for any infringement of patents or other rights of third parties which may result from its use. No license is granted by implication or otherwise under any patent or patent rights of SGS-THOMSON Microelectronics. Specifications mentioned in this publication are subject to change without notice. This publication supersedes and replaces all information previously supplied. SGS-THOMSON Microelectronics products are not authorized for use as critical components in life support devices or systems without express written approval of SGS-THOMSON Microelectronics.

© 1994 SGS-THOMSON Microelectronics - All Rights Reserved

SGS-THOMSON Microelectronics GROUP OF COMPANIES

Australia - Brazil - France - Germany - Hong Kong - Italy - Japan - Korea - Malaysia - Malta - Morocco - The Netherlands - Singapore - Spain - Sweden - Switzerland - Taiwan - Thailand - United Kingdom - U.S.A.