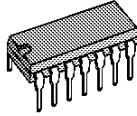
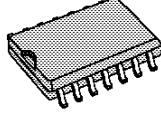

LOW VOLTAGE TELEPHONE SPEECH CIRCUITS

PRELIMINARY DATA

- OPERATION DOWN TO 1.6V / 6.5mA
- DTMF & BEEP TONE INPUTS
- EXTERNAL MUTING FOR EARPHONE AND MICROPHONE
- SUITABLE FOR DYNAMIC EARPHONE AND DYNAMIC OR ELECTRET MICROPHONE
- AGC CONTROL ON BOTH SENDING AND RECEIVING

DIP14 **SO14**

ORDERING NUMBERS:

L3281AB L3281AD1

DESCRIPTION

The L3281 is an electronic speech circuit developed to replace hybrid circuits in telephone sets that can be operated in parallel with other phones.

BLOCK DIAGRAM

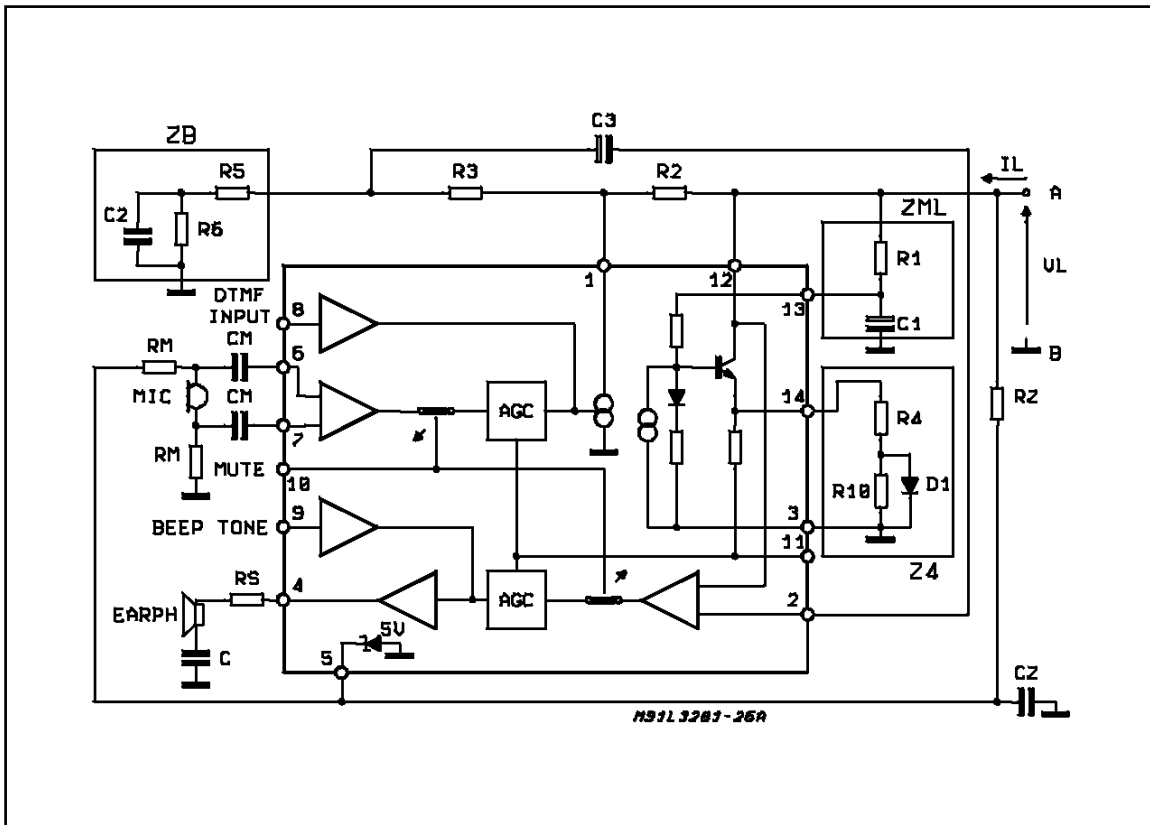

PIN CONNECTION (top view)

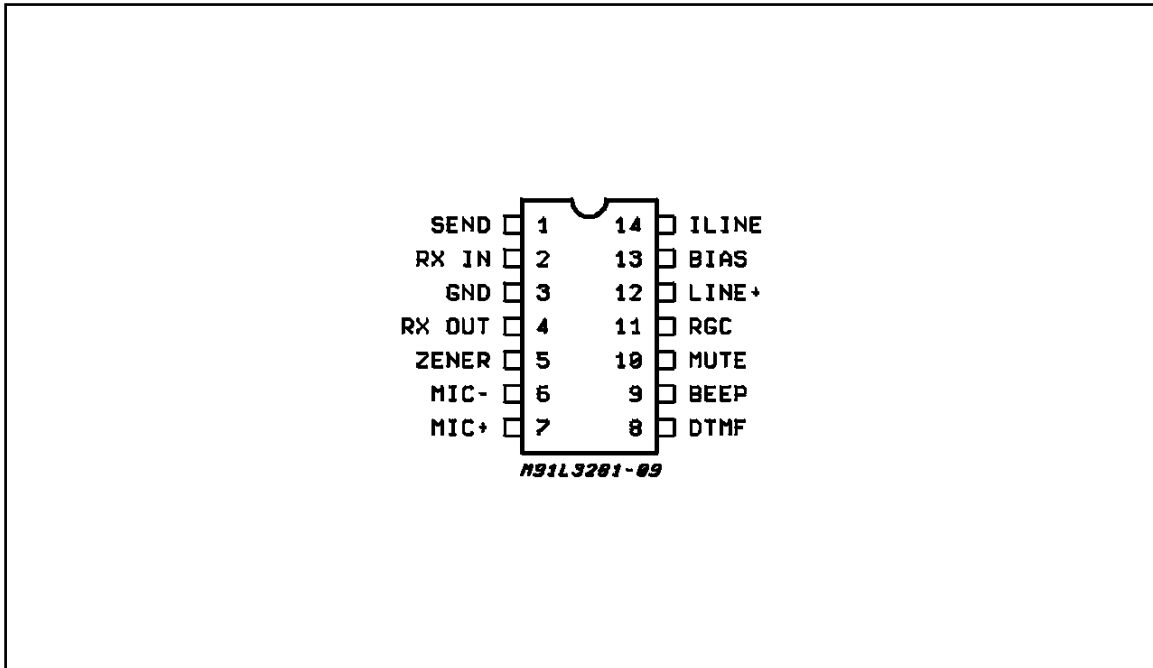

ABSOLUTE MAXIMUM RATINGS

Symbol	Parameter	Value		Unit
		DIP-14	SO-14	
V_L	Line Voltage (3 ms pulse)	15		V
I_L	Line Current	150		mA
P_{tot}	Total Power Dissipation, $T_{amb} = 55^\circ\text{C}$	1.0	0.6	W
T_{op}	Operating Temperature	- 20 to 55		$^\circ\text{C}$
T_j	Junction Temperature	- 65 to 150		$^\circ\text{C}$

THERMAL DATA

Symbol	Parameter	Value		Unit
		DIP-14	SO-14	
$R_{th\ j-amb}$	Thermal Resistance Junction Ambient Max	90	130	$^\circ\text{C}/\text{W}$

TEST CIRCUITS
Figure 1.

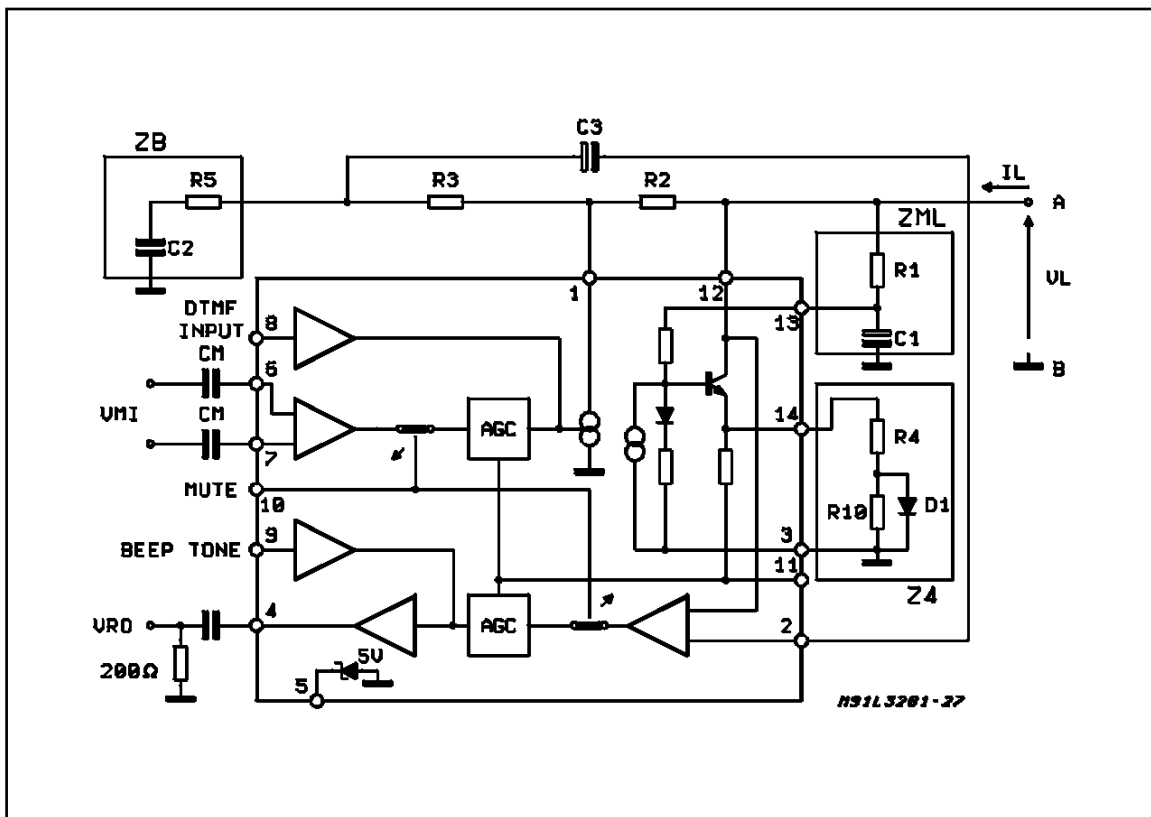

Figure 2.

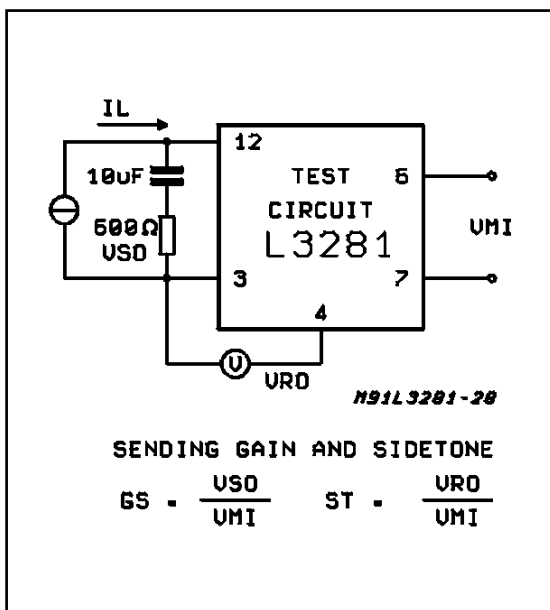
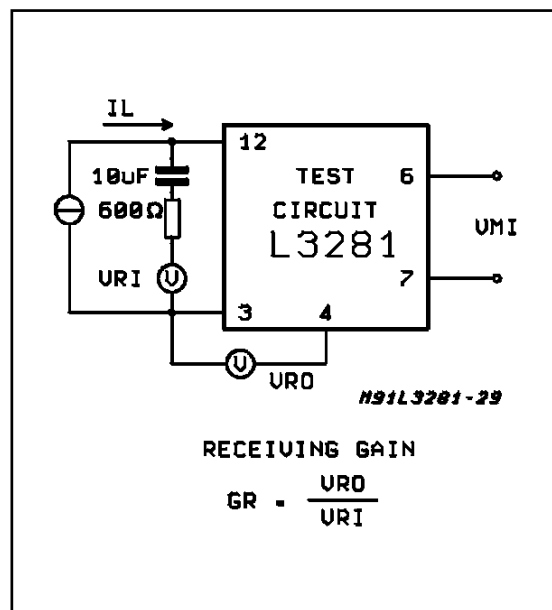

Figure 3.



ELECTRICAL CHARACTERISTICS $I_L = 20$ to 100mA ; $R_4 = (51\Omega // \text{diode}) + 33\Omega$;
 $T = 25^\circ\text{C}$; $f = 1\text{kHz}$; Unless Otherwise Specified

Symbol	Parameter	Test Condition	Min.	Typ.	Max.	Unit
V_I	Line Voltage	$I_L = 6.5\text{mA}$		1.65		V
		$I_L = 20\text{mA}$		3.4	3.7	V
		$I_L = 50\text{mA}$		6.0	6.5	V
		$I_L = 80\text{mA}$		8	9.5	V
CMRR	Common Mode Rej. Ratio		50			dB
G_{tx}	Sending Gain	$V_{mi} = 10\text{mV}$; $I_L = 20\text{mA}$	30	31.5	33	dB
DG_{tx}	Delta Sending Gain	$V_{mi} = 10\text{mV}$; $I_L = 70\text{mA}$	- 7.2	-5.7	-4.2	dB
THD_{tx}	Sending Distortion	$V_{so} = 700\text{mV}$; $I_L = 20\text{mA}$			5	%
N_{tx}	Sending Noise	$V_{mi} = 0\text{V}$; $I_L = 50\text{mA}$		- 70		dB
Z_{mi}	Mic. Input Impedance	$V_{mi} = 10\text{mV}$	40			k Ω
G_{rx}	Receiving Gain	$I_L = 20\text{mA}$; $V_{ri} = 0.2\text{V}$	- 10.7	- 9.2	- 7.7	dB
DG_{rx}	Delta Receiving Gain	$I_L = 70\text{mA}$; $V_{ri} = 0.2\text{V}$	- 7.2	- 5.7	- 4.2	dB
THD_{rx}	Receiving Distortion	$V_{ro} = 350\text{mV}$; Load = 350Ω			5	%
		$V_{ro} = 300\text{mV}$; $I_L = 10\text{mA}$			5	%
N_{rx}	Receiving Noise	$V_{ri} = 0\text{V}$		100		μV
Z_{ro}	Rec. Output Impedance	Load = 200Ω ; $V_{ro} = 50\text{V}$		10		Ω
	Sidetone	$V_{mi} = 10\text{mV}$		10	20	dB
Z_m	Line Match. Impedance	$V_{ri} = 0.2\text{V}$	500	600	700	Ω
V_{so}	Sending Output Voltage	$I_L = 6.5\text{mA}$; THD = 5%	100			mV
I_{ro}	Receiving Output Current	$I_L = 6.5\text{mA}$; THD = 5%	0.5			mAp
MU_{lo}	Mute Input Low	Dialing Mode		50	100	μA
MU_{hi}	Mute Input Open	Speaking Mode			1	μA
G_{mf}	DTMF Gain	$V_{mf\text{ IN}} = 10\text{mV}$	14.5	16	17.5	dB
R_{mf}	DTMF Input Impedance		5	10		k Ω
THD_{mf}	DTMF Distortion	$V_{mf\text{ LN}} = 140\text{mV}$			5	%
G_{beep}	Beeptone Gain	$V_{beep\text{ IN}} = 25\text{mV}$		8.5		dB
R_{beep}	Beeptone Input Impedance		5.5	8		k Ω
THD_{beep}	Beeptone Distortion	$V_{beep\text{ IN}} = 100\text{mV}$; $I_L = 20\text{mA}$		0.5	5	%
V_z	Zener Voltage (Pin 5)	$I_z = 1\text{mA}$	4.2	5.1	6.2	V
I_{leak}	Leakage Current, $V_{pin5} = 3\text{V}$			20		μA

LOGIC OF MUTE SWITCHING

MUTE	DTMF	BEEP	MIC IMP	RX IMP
LOW (DIAL)	ACTIVE TO LINE OUTPUT	ACTIVE TO EARPHONE OUTPUT	MUTED	MUTED
OPEN (SPEECH)	ACTIVE TO LINE OUTPUT	ACTIVE TO EARPHONE OUTPUT	ACTIVE	ACTIVE

CIRCUIT DESCRIPTION

TWO TO FOUR WIRE CONVERSION

The L3281AB is based on a Wheatstone bridge configuration. To balance the bridge the following relation must be satisfied:

$$\frac{Z_L // Z_m}{Z_b} = \frac{R_2}{R_3}$$

The AC signal from the microphone is sent to one diagonal of the bridge (pins 1 and 3). A small percentage of the signal power is lost on Z_b (being Z_b > (Z_m//Z_i)); the main part is sent to the line via R₂.

In receiving mode, the AC signal coming from the LINE is sensed across the second diagonal of the bridge (pins 12 and 2).

The impedance Z_m and Z_b can be complex.

Figure 4: 2/4 Wire Conversion

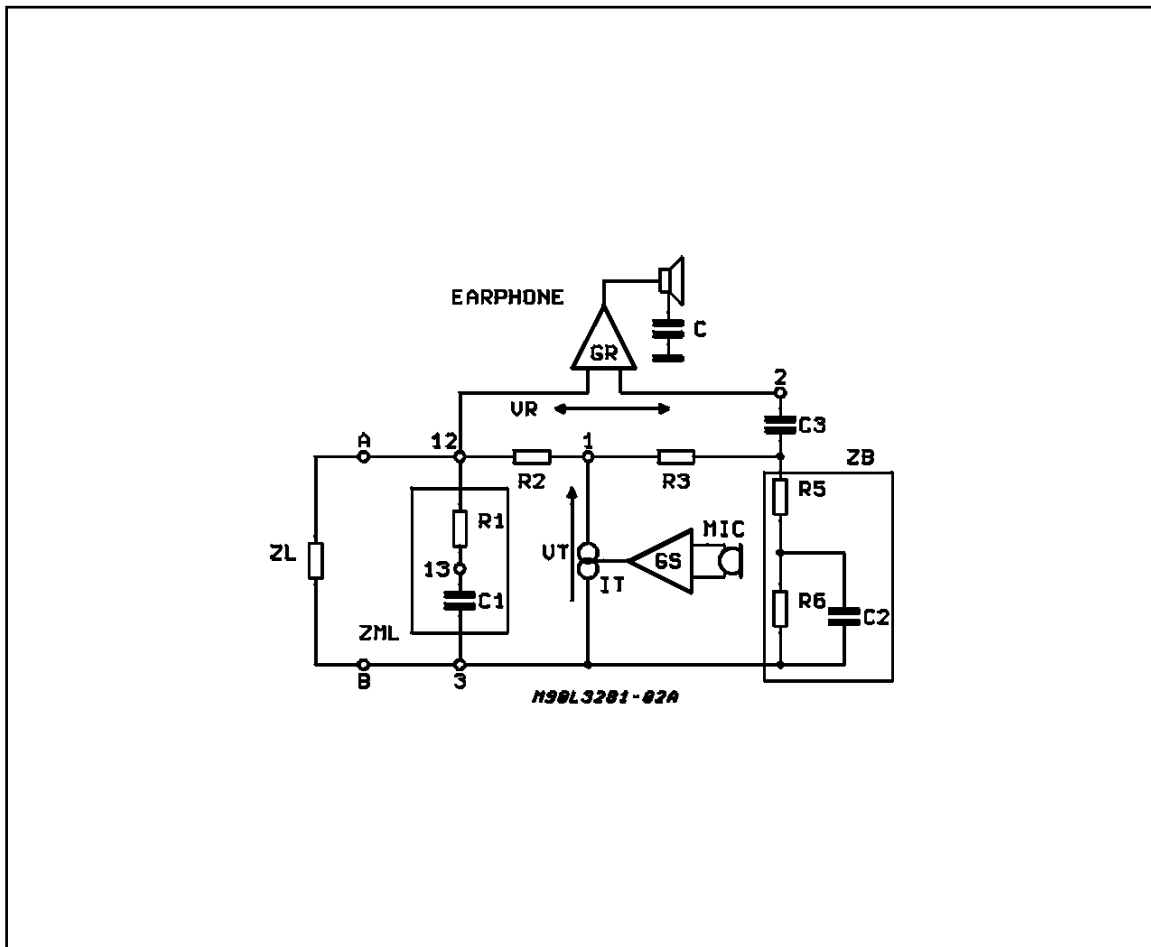

DC CHARACTERISTIC

The fig.5 shows the equivalent simplified circuit of the DC regulator that provides to give the opportune DC impedance Zdc.

$$V_L = \left[\frac{I_{dc} \cdot Z_4}{R_B} \cdot (R_A + R_B) \right] + V_D + V_{R1}$$

$$V_L = \left[(I_{dc} \cdot Z_4) \cdot \left(\frac{R_A}{R_B} + 1 \right) \right] + V_D + V_{R1}$$

since $R_A = R_B$

$$V_L = (I_{dc} \cdot Z_4 \cdot 2) + V_D + V_{R1}$$

When $I_L = 18 \text{ mA}$ and considering neglectable the $V_D + V_{R1}$ variation versus line current :

$$Z_{DC} = \frac{\Delta V_L}{\Delta I_{dc}} = 2 \cdot Z_4$$

At $I_L = 6.5 \text{ mA}$ no current flows through Z_4 but only in the rest of the circuit for internal biasing ($I_o; I_a$). The bias current I_o is fixed by the resistor R_2 . The line voltage in this case is :

$$V_L = I_a R_A + V_{R1} = 1.6 \text{ V}$$

The Fig.6 shows the DC characteristic (voltage between pin 12 and pin 3 versus line current). The device own an equivalent zener voltage at pin 5 that can be used as supply voltage for electret microphone (see Block Diagram).

The value of the resistor R_2 and the capacitor C_2 should be chosen in order to not affect the AC line impedance. The Fig.7 shows the zener

Figure 5: Equivalent Simplified Circuit

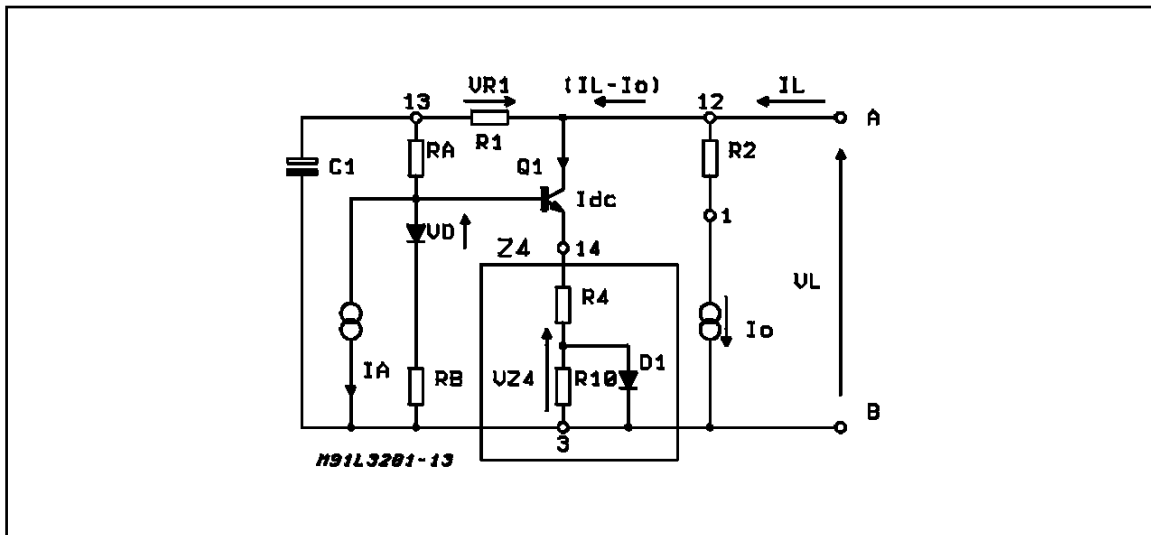

equivalent.

The zener voltage will be:

$$V_z = \left(\frac{70K}{13.6K} + 1 \right) \cdot V_{be}$$

It is possible to supply 1mA to the electret voltage if $V_L > (1\text{mA} + I_z) \cdot R_z + V_z$

Figure 6: Low Voltage Speech Circuit.

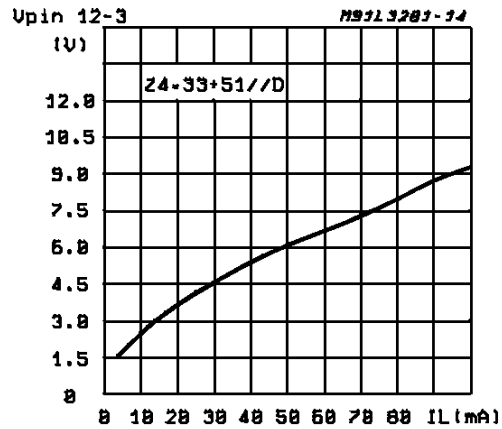
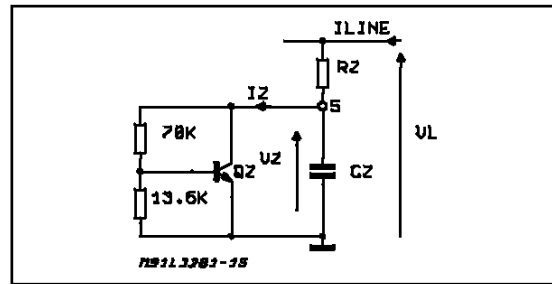

Figure 7: Zener Equivalent.



AC CHARACTERISTIC

The AC Impedance measured at line terminals is equal to:

$$Z_m = (R_1 + \frac{1}{j\omega C_1}) // (R_2 + R_3 + Z_b)$$

The value of the capacitor C1 must be in the range of 22 μF to 100 μF.

The external resistor R1 can be replaced by a resistor/capacitor network in order to realize a complex Impedance Zm.

TRANSMITTING CIRCUIT

The first block of the TX stage is basically a differential amplifier which converts voltage to current. The inputs are internally polarized at 300 mVdc. The differential Input impedance is 60 KΩ to allow

a good matching to microphone. The AGC in TX is function of voltage at pin 14 in order to decrease to max gain of 5.5dB to 6.0dB when the line current increases.

RECEIVING CIRCUIT

Fig.9 shows the equivalent receiving circuit. The differential input of RX signal across R2+R3 is transferred to the AGC block when the mute signal (pin 10) is not active.

The AGC in RX is a function of the voltage at pin 14 and decreases the gain when the line current increases (5.5dB to 6.0dB).

The final stage is a single ended amplifier with low output impedance optimized to drive magnetic/dynamic transducers.

Figure 8: Equivalent Transmitting Circuit.

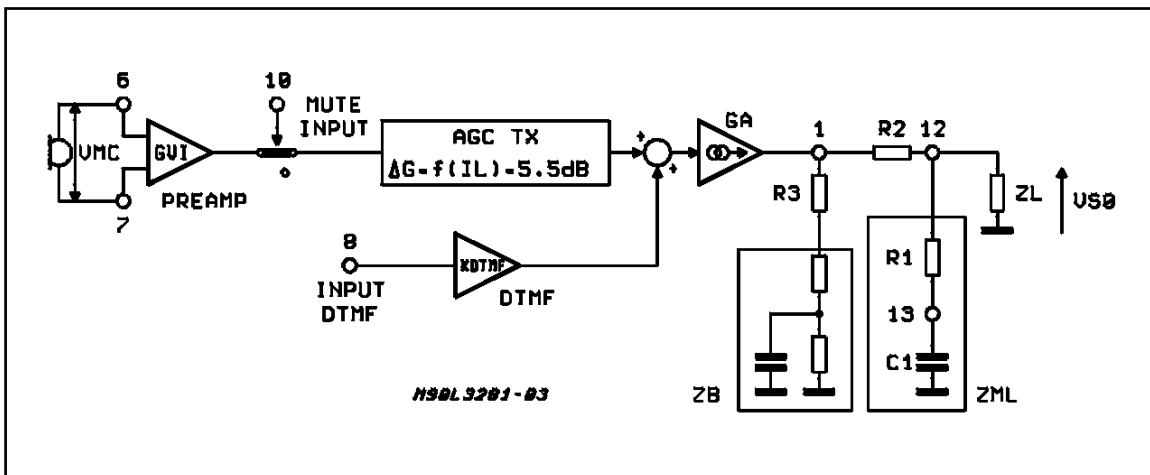
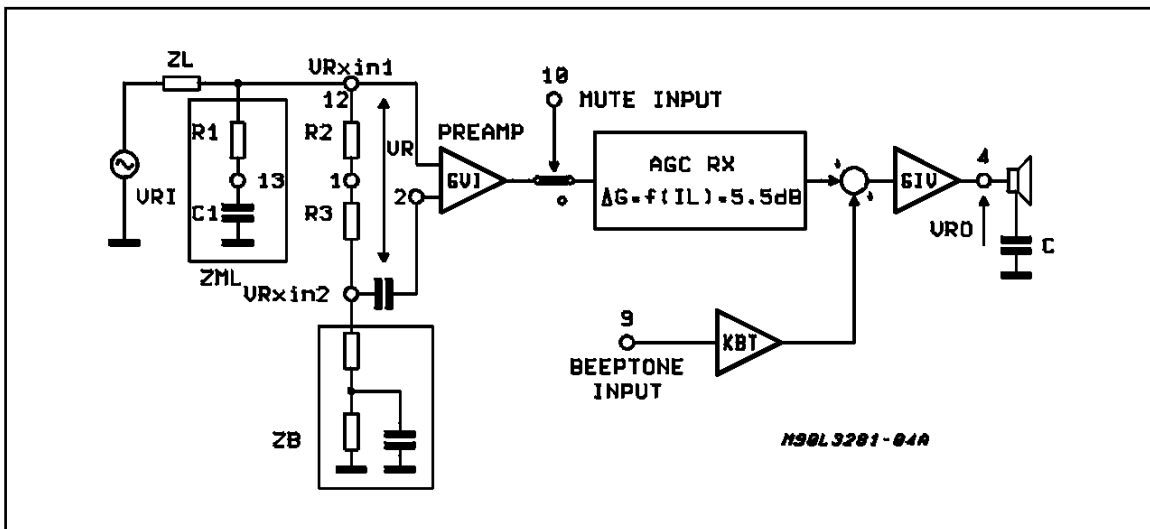
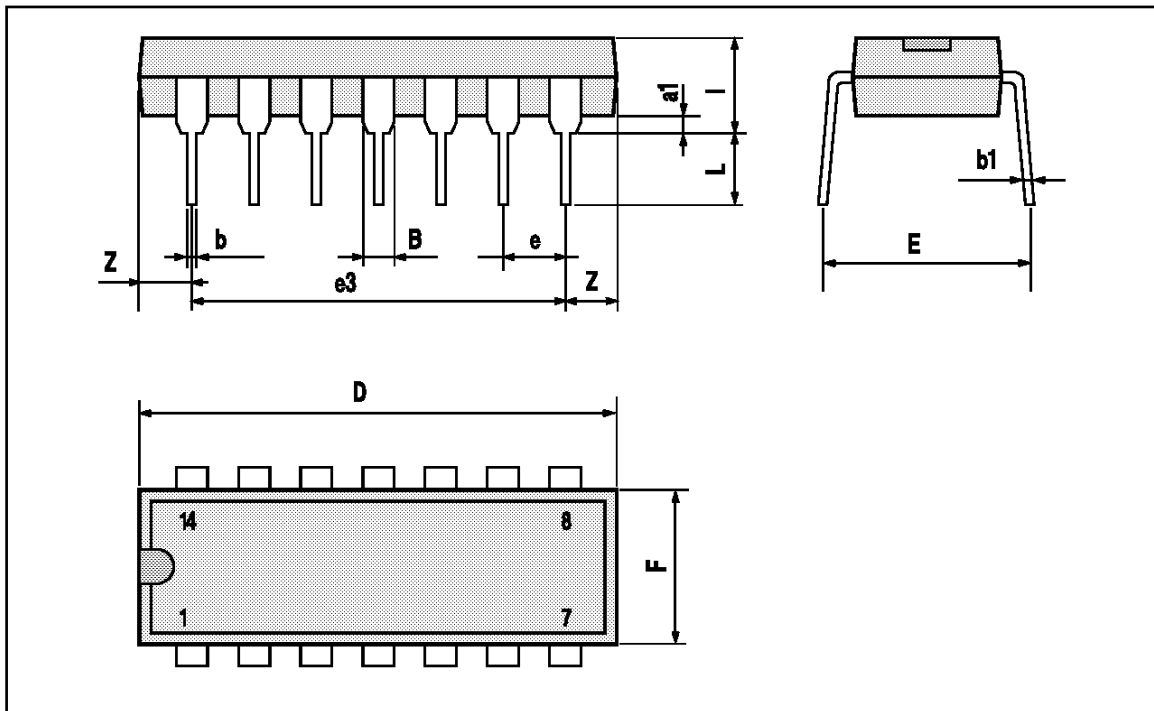

Figure 9: Equivalent Receiving Circuit.



DIP14 PACKAGE MECHANICAL DATA

DIM.	mm			inch		
	MIN.	TYP.	MAX.	MIN.	TYP.	MAX.
a1	0.51			0.020		
B	1.39		1.65	0.055		0.065
b		0.5			0.020	
b1		0.25			0.010	
D			20			0.787
E		8.5			0.335	
e		2.54			0.100	
e3		15.24			0.600	
F			7.1			0.280
l			5.1			0.201
L		3.3			0.130	
Z	1.27		2.54	0.050		0.100



SO14 PACKAGE MECHANICAL DATA

DIM.	mm			inch		
	MIN.	TYP.	MAX.	MIN.	TYP.	MAX.
A			1.75			0.069
a1	0.1		0.2	0.004		0.008
a2			1.6			0.063
b	0.35		0.46	0.014		0.018
b1	0.19		0.25	0.007		0.010
C		0.5			0.020	
c1	45° (typ.)					
D	8.55		8.75	0.336		0.344
E	5.8		6.2	0.228		0.244
e		1.27			0.050	
e3		7.62			0.300	
F	3.8		4.0	0.15		0.157
L	0.5		1.27	0.020		0.050
M			0.68			0.027
S	8° (max.)					

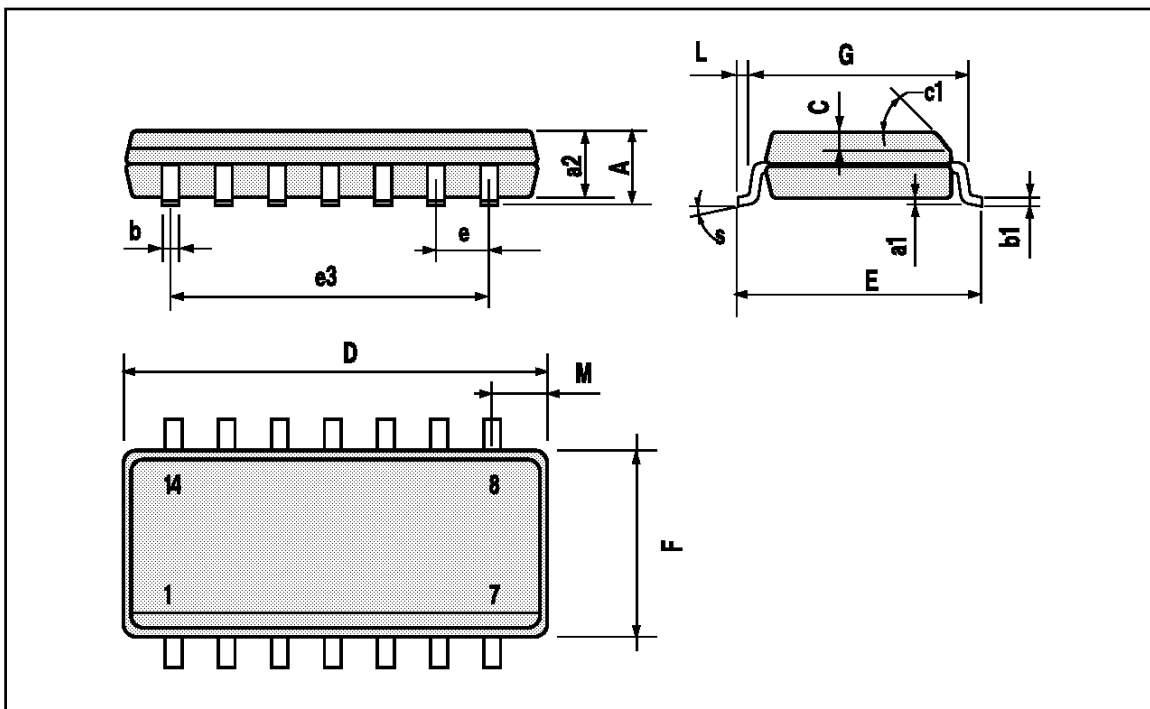

Information furnished is believed to be accurate and reliable. However, SGS-THOMSON Microelectronics assumes no responsibility for the consequences of use of such information nor for any infringement of patents or other rights of third parties which may result from its use. No license is granted by implication or otherwise under any patent or patent rights of SGS-THOMSON Microelectronics. Specifications mentioned in this publication are subject to change without notice. This publication supersedes and replaces all information previously supplied. SGS-THOMSON Microelectronics products are not authorized for use as critical components in life support devices or systems without express written approval of SGS-THOMSON Microelectronics.

© 1994 SGS-THOMSON Microelectronics - All Rights Reserved

SGS-THOMSON Microelectronics GROUP OF COMPANIES

Australia - Brazil - France - Germany - Hong Kong - Italy - Japan - Korea - Malaysia - Malta - Morocco - The Netherlands
Singapore - Spain - Sweden - Switzerland - Taiwan - Thailand - United Kingdom - U.S.A.