

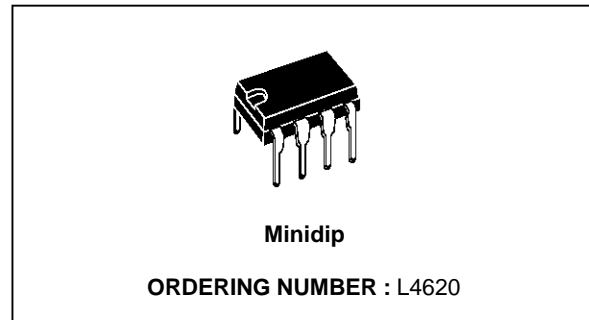
**LIQUID LEVEL ALARM**

- DRIVES DIRECTLY 300 mA ALARM LOAD
- PROGRAMMABLE INPUT POLARITY TO ACTIVATE THE OUTPUT STAGE
- PROGRAMMABLE DELAY TIME
- PROGRAMMABLE OUTPUT DUTY CYCLE
- OUTPUT SHORT CIRCUIT PROTECTION
- OVERVOLTAGE AND THERMAL PROTECTION

**DESCRIPTION**

The L4620 is an integrated circuit, designed for the liquid level control in automotive applications. The liquid level is indicated by an attenuation between transmitted and received signal across a sensor tip in the liquid. If the attenuation exceeds an internal threshold - sensor tip outside the liquid or liquid temperature higher than a determined value - a squarewave alarm output indicates an insufficient liquid condition. If the liquid level is restored before the end of a delay time the alarm is not activated.

Through two pins it is possible to program : the delay

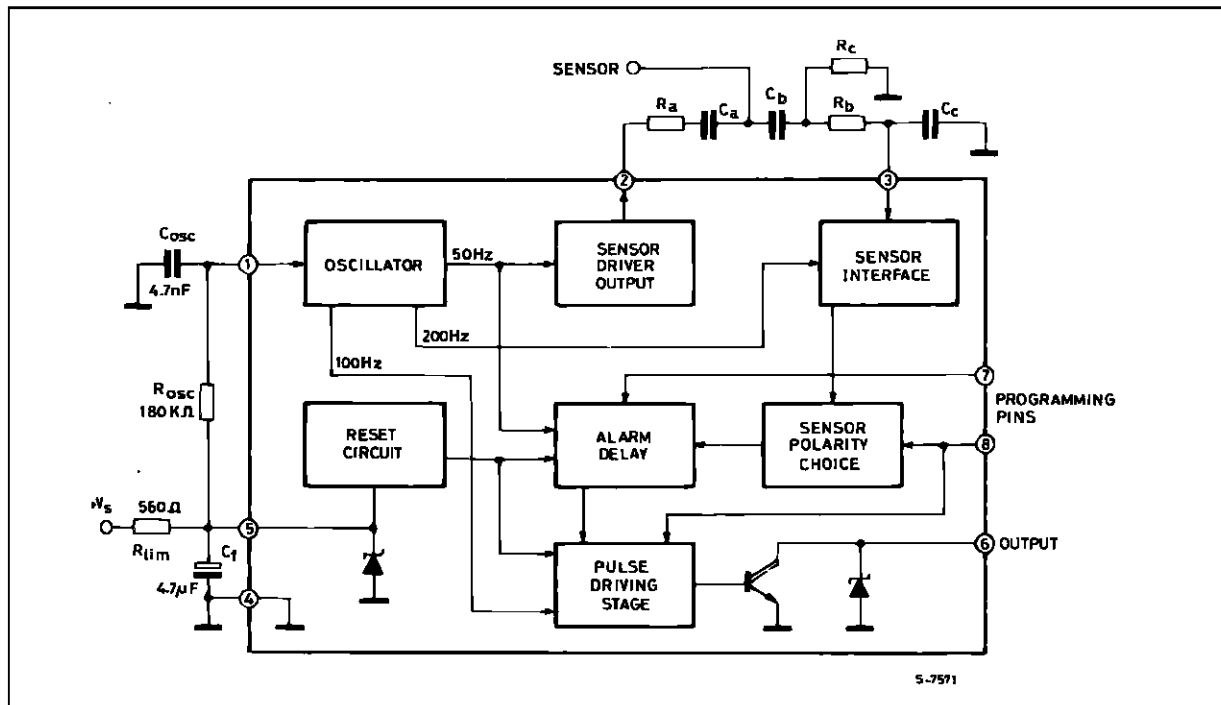


time to activate the alarm, the duty cycle of the output squarewave, the polarity of the input threshold of the sensor for alarm activation.

The above features make the L4620 particularly versatile for many applications and give the possibility to use various sensor types.

Internal circuits prevent spurious indications from the liquid sensor and a latch keeps the alarm activated until the supply voltage is switched off. The device includes thermal shutdown protections.

**BLOCK DIAGRAM**

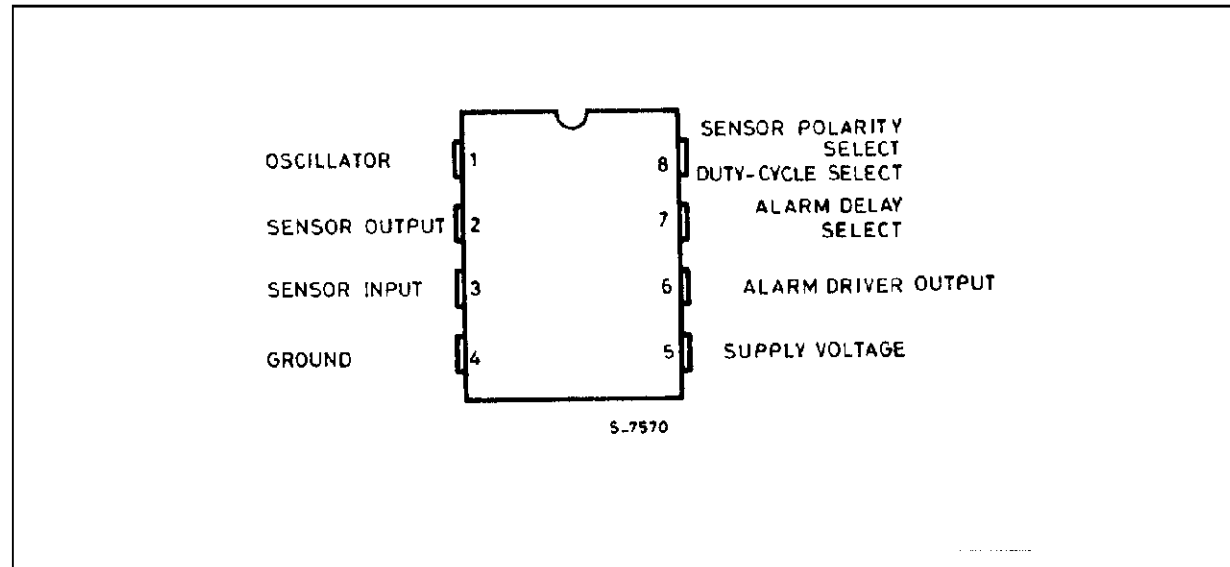


## L4620

### ABSOLUTE MAXIMUM RATINGS

Symbol	Parameter	Value	Unit
$I_S$	Supply Current ( $V_S > V_Z$ )	200	mA
$V_3$	Sensor Input Voltage ( $V_2$ High)	7	V
$I_{out}$	Output Current	500	mA
$P_{tot}$	Power Dissipation at $T_{amb} = 70^\circ\text{C}$	0.8	W
$T_j, T_{stg}$	Junction and Storage Temperature Range	- 55 to 150	$^\circ\text{C}$

### PIN CONNECTION (top view)



### THERMAL DATA

Symbol	Parameter	Value	Unit
$R_{th\ j-amb}$	Thermal Resistance Junction-ambient	Max 100	$^\circ\text{C/W}$

**PIN FUNCTION** (Block Diagram)

N°	Name	Function
1	Oscillator	A capacitor $C_{OSC}$ connected to ground and a resistor $R_{OSC}$ connected to pin 5 (supply voltage) set the frequency of the internal oscillator. The period is given by: $T_{OSC} = 0.693 (R_{OSC} + 5000) C_{OSC}$
2	Sensor Output	A squarewave is available at this pin to drive the external sensor. The output frequency is 1/32 of the internal oscillator $f_{osc}$ , i.e. 50Hz using the values of $R_{OSC} = 180k\Omega$ and $C_{OSC} = 4.7nF$ for the external components.
3	Sensor Input	Connection for liquid level sensing. During the zero level of the squarewave signal at pin 2, the internal sensing circuit is disabled. During the high level of the wave shape the input is compared with a threshold which depends on the output sensor volta $V_{SENSH} = 0.4V_2$ (typ). If the input voltage becomes higher than the above $V_{SENSH}$ , the $V_{sens}$ value is reduced to $V_{SENSL} = 0.22V_2$ (typ), providing an hysteresis available with both the programmable polarities.
4	GND	This pin must be connected to ground.
5	Supply Voltage	Supply voltage input. A 4.5V (typical) zener is present at the input. The external resistor limits the current through the zener for high supply voltages. Moreover when the voltage at this pin is down 2.5V (typical) the internal reset circuit is activated
6	Alarm Driver Output	An internal open collector stage is available at this pin to drive the external alarm indicator by a rectangular waveshape. The output period depends on the external component $R_{OSC}$ and $C_{OSC}$ . Using the recommended values of block diagram th
7	Alarm Delay Select	This program pin selects the alarm delay to activate the output stage after a low liquid level indication of the sensor. The delay depends on the internal oscillator frequency. Refer to application circuit, if this pin is kept low the typical delay is 10.
8	Sensor Polarity Select Output Duty-cycle Select	Through this pin it is possible to program both the sensor polarity with respect to the internal threshold and the duty-cycle of the output waveform which drives the alarm. When this pin is kept low the output rectangular wave duty cycle is 1:64 ( $T = 320ms$ , $t = 5ms$ in fig. 2) and the output is activated, after the delay time, if the voltage at pin 3 is higher than $V_{SENS}$ . When the voltage at this pin is high the output duty cycle is 50% ( $t = 160ms$ ) and the output goes on, after the delay

## L4620

**ELECTRICAL CHARACTERISTICS** ( $T_{amb} = 25\text{ }^{\circ}\text{C}$ , unless otherwise specified. Refer to block diagram for external component values)

Symbol	Parameter	Test Conditions	Min.	Typ.	Max.	Unit
$V_Z$	Internal Zener Voltage (pin 5)	$I_S = 24\text{ mA}$	4	4.5	5	V
$I_S$	Supply Current (pin 5)	$V_S = 3.8\text{ V}$		6.5	11	mA
$f_{osc}$	Oscillator Frequency (pin 1)	$R_{osc} = 180\text{ k}\Omega$ , $C_{osc} = 4.7\text{ nF}$	1.45	1.6	1.75	kHz
$V_7, V_8$	Programming Pins Input Voltage (pin 7, 8)	Low State			0.3	V
		High state	2			V
$I_7, I_8$	Programming Pins Input Current (pin 7, 8)	$V_7 = V_8 = 0\text{ V}$	-1			$\mu\text{A}$
		$V_7 = V_8 = V_Z$			150	$\mu\text{A}$
$V_2$	Sensor Drive Output Voltage, (*)	$V_2 = \text{Low}$ , $I_2 = 1\text{ mA}$			0.4	V
		$V_2 = \text{High}$ , $I_2 = 1\text{ mA}$	$V_Z - 1$		$V_Z - 0.4$	V
$I_2$	Sensor Driver Output Current		-1		1	mA
$V_{SENH}/V_2$	Sensor Input High Threshold Voltage Versus $V_2$ (pin 3)	$V_2 = \text{High}$ $V_{pin\ 3} < V_{SENH}$	0.33	0.4	0.47	
$\frac{V_{sens}}{V_2}$	Sensor Input Low Threshold Voltage Versus $V_2$ (pin 3)	$V_2 = \text{High}$ $V_{pin\ 3} > V_{SENH}$	0.15	0.22	0.29	
$V_{clamp3L}$	Sensor Input Clamping Voltage (pin 3)	$-100\ \mu\text{A} < I_{sens} < 100\ \mu\text{A}$ $V_2 = \text{Low}$	-0.1		0.1	V
$V_{clamp3H}$		$V_2 = \text{High}$ $I_3 = -100\ \mu\text{A}$	-0.8	-0.6	-0.4	V
		$I_3 = +100\ \mu\text{A}$	$V_Z$		$V_Z + 0.8$	V
$I_{sens}$	Sensor Input Bias Current (pin 3)	$V_{sens} = \text{High}$			1.2	$\mu\text{A}$
$T_d$	Delay Time	$f_{osc} = 1.6\text{ kHz}$ $V_7 = \text{Low}$		10.24		sec
		$V_7 = \text{High}$		20.48		sec
$V_{out(sat)}$	Output Stage Saturation Voltage (pin 6) (**)	$I_{out} = 200\text{ mA}$			1.3	V
$V_{out(clamp)}$	Output Stage Overvoltage Protection (pin 6)	$I_{out} = 70\text{ mA}$	19	21	23	V

\*) This is a squarewave signal. The frequency is given by :  $f = \frac{1}{32} f_{osc}$ .

\*\*) The output squarewave signal frequency is given by  $f = \frac{1}{512} f_{osc}$ .

The duty cycle depends on the state of the pin 8 and can be or 1 : 2 or 1 : 64, i.e. refer to figure 2,  $T = 320\text{ ms}$ ,  $t = 160\text{ or }5\text{ ms}$  when the oscillator frequency  $f_{osc} = 1.6\text{ KHz}$ .

## CIRCUIT OPERATION

The L4620 liquid level alarm is designed to operate with a variety of sensor types which change impedance depending on whether the sensor is above or below the level of a liquid. If the impedance variation of the liquid itself is sensed, a very simple sensor (two electrodes) can be used. The output stage drives directly the alarm indicator with a 300mA rectangular wave signal, the duty cycle of which is programmable.

### SENSOR INTERFACE.

As shown in the application circuit, the sensor is connected so that it varies the attenuation of a square-wave signal between pin 2 and pin 3 where its positive half cycle is compared with the reference threshold (with hysteresis).

This frequency, generated internally by a 50% duty cycle oscillator, is 50Hz in the typical application ( $R_{OSC} = 180K\Omega$   $C_{OSC} = 4.7nF$ ).

The threshold of the sensor input is a function of the output voltage at pin 2. The hysteresis is provided by a Schmitt trigger comparator. As shown in figure 1, this gives hysteresis with either threshold polarity selected.

The AC driving of the level sensor allows the use of a capacitive filter ( $C_A$ ,  $C_B$ ,  $C_C$  in block diagram) which acts as a bandpass filter at the frequency used. The resistor  $R_C$  in the application circuit biases the sensor input stage. In this way the interference problems typical of automotive applications are reduced considerably. If, however, it is not necessary to decouple and filter the sensor a simple resistive network may be used, eliminating the capacitors.

### SPURIOUS INDICATION PROTECTION.

To prevent spurious alarm signals when the liquid is

agitated or in the presence of interference, the device includes two protection mechanisms :

Firstly, the sensor interface which samples the positive half cycle of the sensor signal activates its output only if there are four consecutive alarm condition indications. Secondly, the alarm output stage is only activated after an externally programmable delay. During this delay if the alarm condition ceases the alarm output will not be activated.

Using the values  $C_{OSC} = 4.7nF$  and  $R_{OSC} = 180K\Omega$ , which give a typical oscillator frequency of 1.6KHz, delays of about 10 s (programming pin 7 low) or 20s.

### INTERNAL MEMORY.

When the alarm output has been activated an internal latch holds it in the active state until the power supply is removed. This feature ensures that the alarm will not be interrupted if the sensor connection breaks.

### OUTPUT STAGE.

Through pin 8 it is possible to program the duty cycle of the alarm signal waveform (see figure 2). When pin 8 is high the output signal has a duty cycle of 50% ; if pin 8 is low the duty cycle is 1 : 64. The period of the output signal is always 320ms using the component values indicated in block diagram.

The output stage can deliver up to 300mA and is protected internally against overvoltages (by a zener).

A thermal shutdown circuit provides additional protection.

SENSOR INPUT WAVEFORM

Figure 1a : Pin 8 Low ; Alarm with Input Voltage > Threshold.

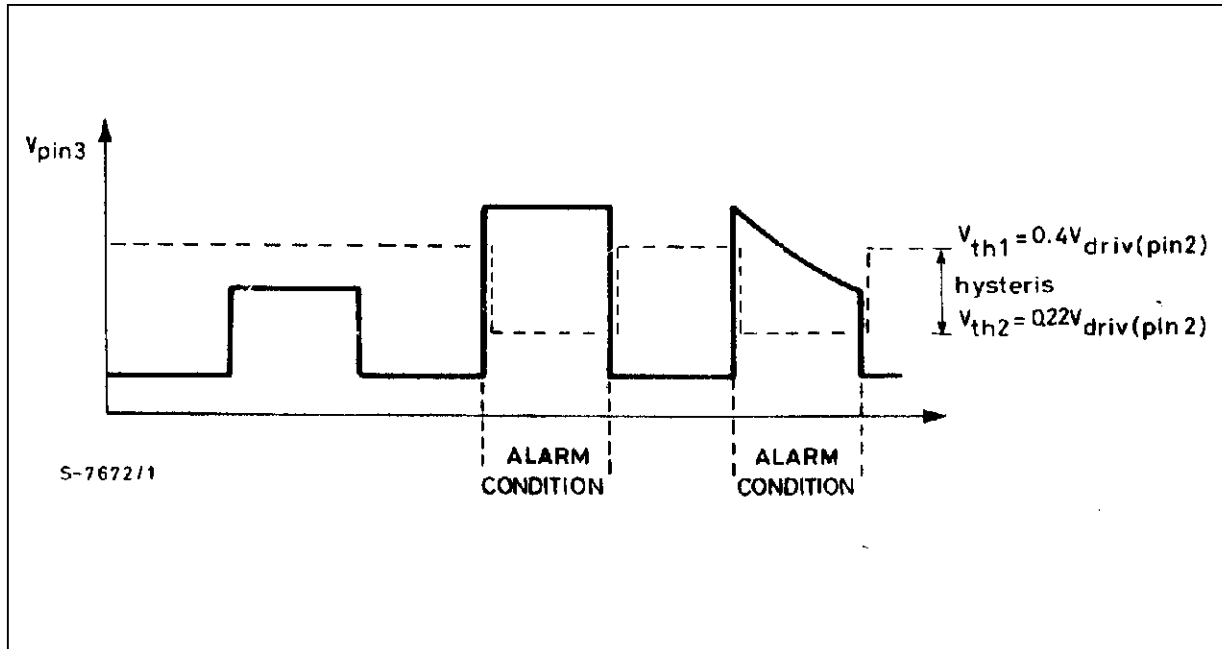
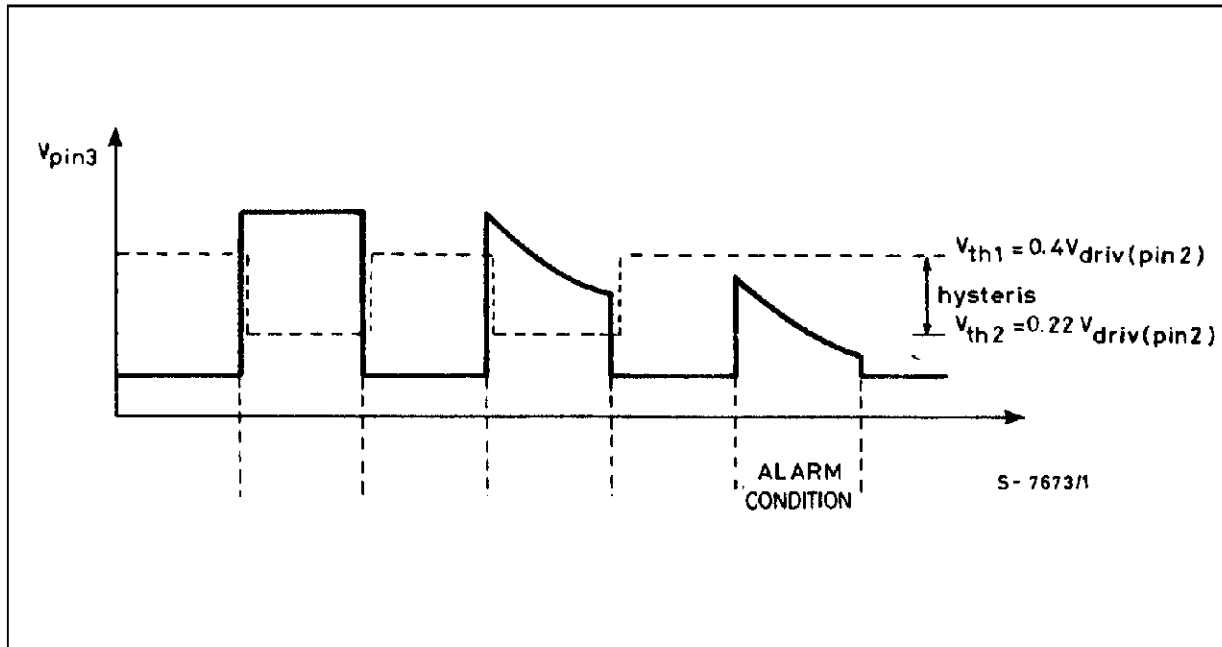
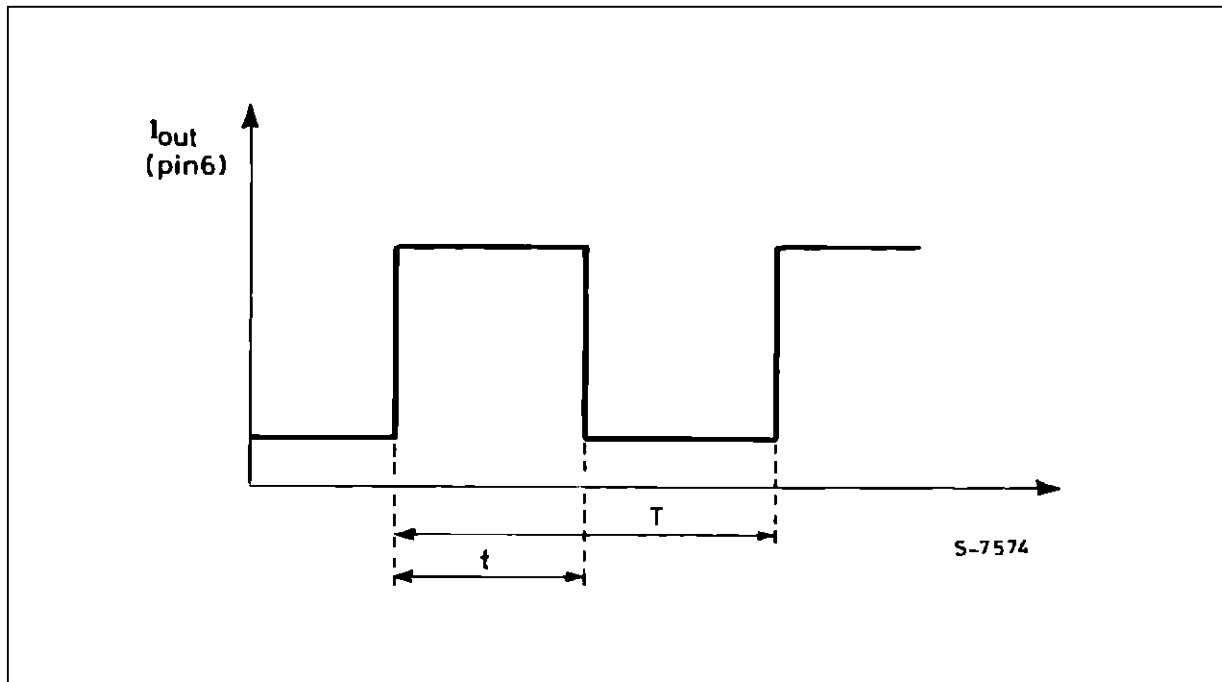


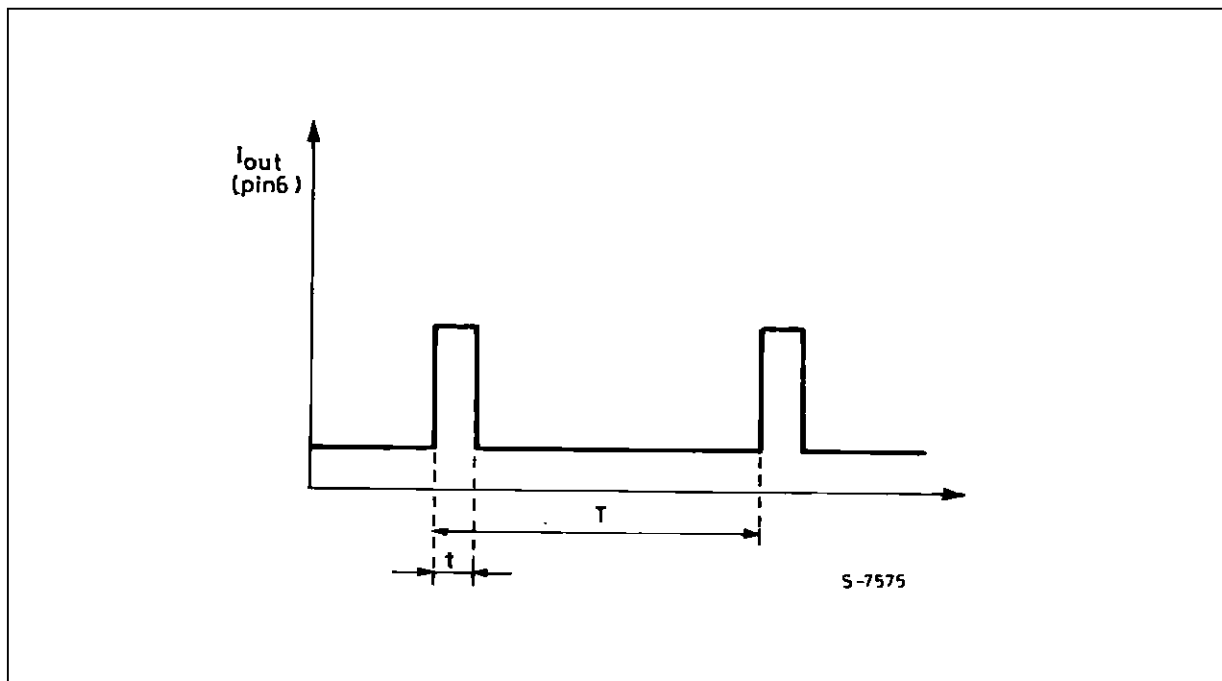
Figure 1b : Pin 8 High ; Alarm with Input Voltage < Threshold.



**Figure 2a** : Output Alarm Waveform with Pin 8 High :  $t = \frac{1}{2} T$ .

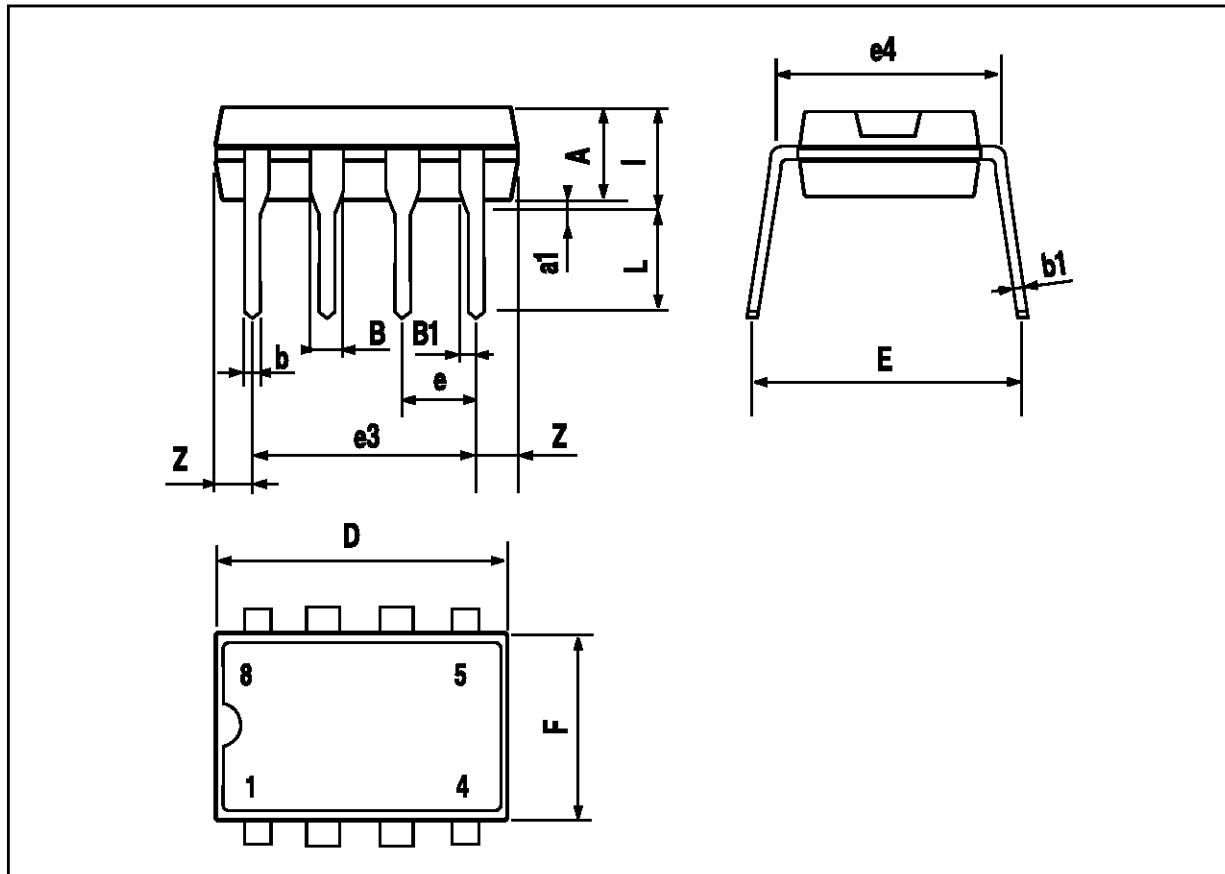


**Figure 2b** : Output Alarm Waveform with Pin 8 Low :  $t = \frac{1}{64} T$ .



MINIDIP MECHANICAL DATA

DIM.	mm			inch		
	MIN.	TYP.	MAX.	MIN.	TYP.	MAX.
A		3.32			0.131	
a1	0.51			0.020		
B	1.15		1.65	0.045		0.065
b	0.356		0.55	0.014		0.022
b1	0.204		0.304	0.008		0.012
D			10.92			0.430
E	7.95		9.75	0.313		0.384
e		2.54			0.100	
e3		7.62			0.300	
e4		7.62			0.300	
F			6.6			0.260
I			5.08			0.200
L	3.18		3.81	0.125		0.150
Z			1.52			0.060



Information furnished is believed to be accurate and reliable. However, SGS-THOMSON Microelectronics assumes no responsibility for the consequences of use of such information nor for any infringement of patents or other rights of third parties which may result from its use. No license is granted by implication or otherwise under any patent or patent rights of SGS-THOMSON Microelectronics. Specifications mentioned in this publication are subject to change without notice. This publication supersedes and replaces all information previously supplied. SGS-THOMSON Microelectronics products are not authorized for use as critical components in life support devices or systems without express written approval of SGS-THOMSON Microelectronics.

© 1995 SGS-THOMSON Microelectronics - All Rights Reserved

SGS-THOMSON Microelectronics GROUP OF COMPANIES

Australia - Brazil - France - Germany - Hong Kong - Italy - Japan - Korea - Malaysia - Malta - Morocco - The Netherlands - Singapore - Spain - Sweden - Switzerland - Taiwan - Thailand - United Kingdom - U.S.A.