

VERY LOW DROP VOLTAGE REGULATORS

- INPUT/OUTPUT DROP TYP. 0.4V
- 400mA OUTPUT CURRENT
- LOW QUIESCENT CURRENT
- REVERSE POLARITY PROTECTION
- OVERVOLTAGE PROTECTION ($\pm 60V$)
- FOLDBACK CURRENT LIMITING
- THERMAL SHUTDOWN

DESCRIPTION

L4800 series devices are voltage regulators with a very low voltage drop (typically 0.4V at full rated current), output current up to 400mA, low quiescent current and comprehensive on-chip protection. These devices are protected against load dump and field decay transients of $\pm 60V$, polarity reversal and overheating. A foldback current limiter protects against load short circuits. Available in 5V, 8.5V, 9.2V, 10V and 12V versions (all $\pm 4\%$, $T_1 = 25^\circ C$) these regulators are designed for automotive, industrial and consumer applications where low consumption is particularly important.

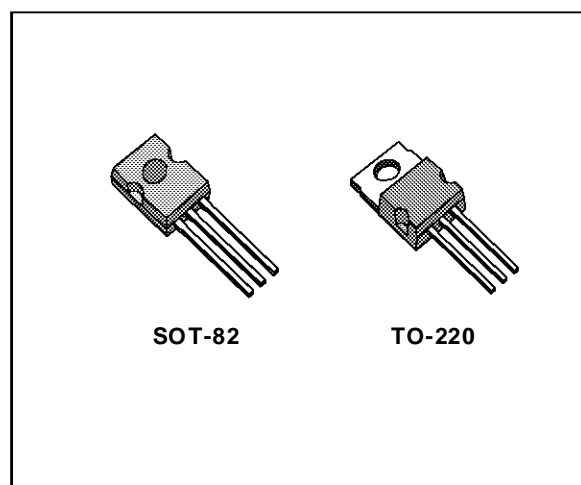

In automotive applications the L4805 is ideal for 5V logic supplies because it can operate even when the battery voltage falls below 6V. In battery backup and standby applications the low consumption of these devices extends battery life.

BLOCK DIAGRAM

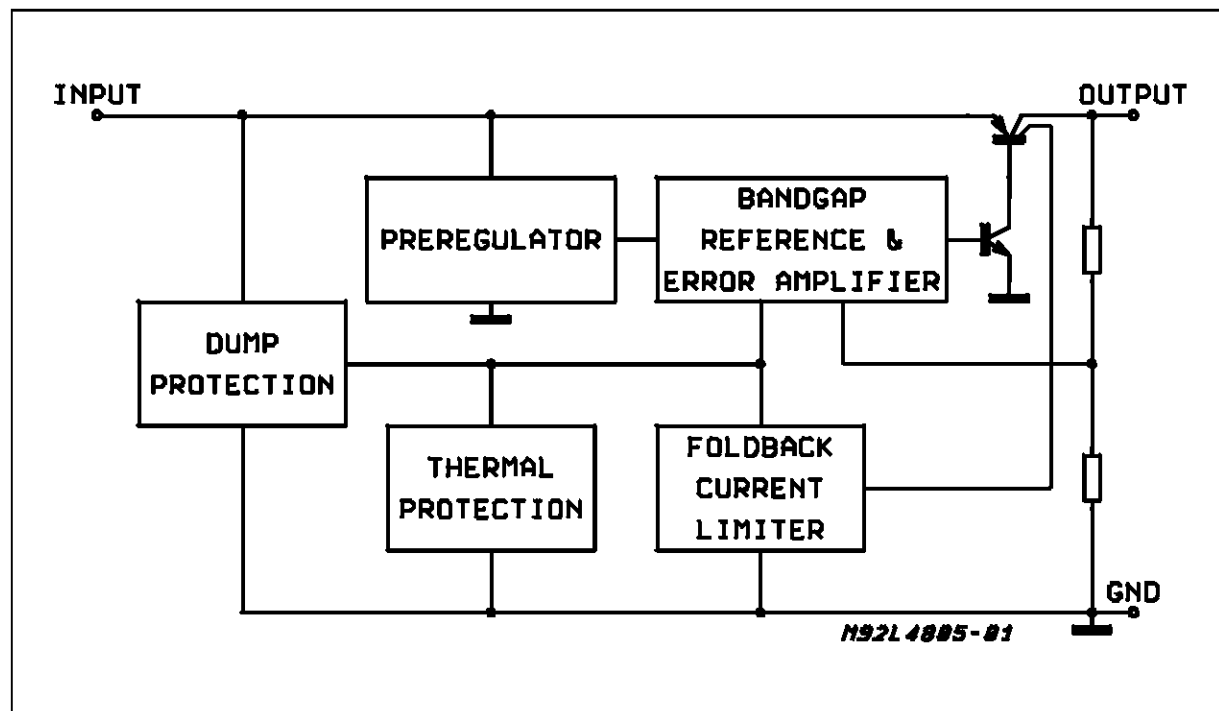

ABSOLUTE MAXIMUM RATINGS

| Symbol | Parameter | Value | Unit |
|-----------------------|--|----------------|------------|
| V_i | DC Input Voltage | + 35 | V |
| | DC Input Reverse Voltage | - 18 | V |
| | Transient Input Overvoltages : Load Dump : $5\text{ms} \leq T_{\text{rise}} \leq 10\text{ms}$, τ_f Fall Time Constant = 100ms, $R_{\text{source}} \leq 0.5\Omega$ Field Decay : $5\text{ms} \leq t_{\text{fall}} \leq 10\text{ms}$, $R_{\text{source}} \leq 10\Omega$ τ_r Rise Time Constant = 33ms | 60 - 60 | V V |
| T_j, T_{stg} | Junction and Storage Temperature Range | - 55 to + 150 | °C |

THERMAL DATA

| Symbol | Parameter | | SOT82 | TO220 | Unit |
|------------------------|-------------------------------------|------|-------|-------|------|
| $R_{\text{th j-case}}$ | Thermal Resistance Junction-case | Max. | 8 | 4 | °C/W |
| $R_{\text{th j-amb}}$ | Thermal Resistance Junction-ambient | Max. | 100 | 75 | °C/W |

PIN CONNECTION (top view)

| Order Codes | | Output Voltage |
|-------------|---------|----------------|
| TO-220 | SOT-82 | |
| L4805CV | L4805CX | 5V |
| L4808CV | L4808CX | 8V |
| L4885CV | L4885CX | 8.5 V |
| L4892CV | L4892CX | 9.2 V |
| L4810CV | L4810CX | 10 V |
| L4812CV | L4812CX | 12 V |

TEST AND APPLICATION CIRCUIT

The output capacitor is required for stability. Though the 100 μF shown is the minimum recommended value, actual size and type may vary depending upon the application load and temperature range. Capacitor effective series resistance (ESR) also factors in the IC stability. Since ESR varies from one brand to the next, some bench work may be required to determine the minimum capacitor value to use in production. Worst-case is usually determined at the minimum ambient temperature and maximum load expected.

Output capacitors can be increased in size to any desired value above the minimum. One possible purpose of this would be to maintain the output voltages during brief conditions of negative input transients that might be characteristics of a particular system.

Capacitors must also be rated at all ambient temperature expected in the system. Many aluminum type electrolytics will freeze at temperatures less than -30°C , reducing their effective capacitance to zero. To maintain regulator stability down to -40°C , capacitors rated at that temperature (such as tantalums) must be used.

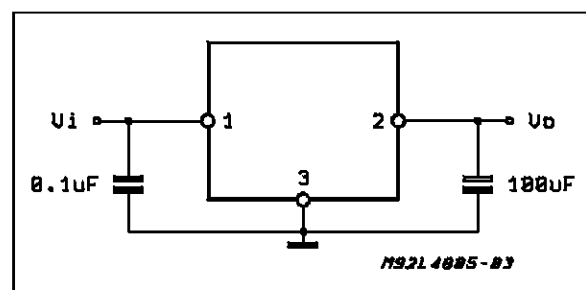

L4805-L4808-L4885-L4892-L4810-L4812

ELECTRICAL CHARACTERISTICS ($V_I = 14.4V$; $C_O = 100\mu F$; $T_j = 25^\circ C$ unless otherwise specified.)

| Symbol | Parameter | Test Condition | Min. | Typ. | Max. | Unit |
|---|--|--|-------|-------|-------|-------------------------------|
| V_O | Output Voltage | $I_O = 5mA$ to 400mA (L4805) | 4.80 | 5.00 | 5.20 | V |
| | | $I_O = 5mA$ to 400mA (L4808) | 7.68 | 8.00 | 8.32 | V |
| | | $I_O = 5mA$ to 400mA (L4810) | 8.16 | 8.50 | 8.84 | V |
| | | $I_O = 5mA$ to 400mA (L4812) | 8.83 | 9.20 | 9.57 | V |
| | | $I_O = 5mA$ to 400mA (L4885) | 9.60 | 10.00 | 10.40 | V |
| | | $I_O = 300mA$ (L4892) | 11.50 | 12.00 | 12.50 | V |
| V_I | Operating Input Voltage | | | | 26 | V |
| $\Delta V_O/V_O$ | Line Regulation | $V_I = 13$ to 26V; $I_O = 5mA$ | | 1 | 10 | mV/V |
| $\Delta V_O/V_O$ | Load Regulation | $I_O = 5$ to 400mA* | | 3 | 15 | mV/V |
| $V_I - V_O$ | Dropout Voltage | $I_O = 400mA^*$ | | 0.4 | 0.7 | V |
| | | $I_O = 150mA$ | | 0.2 | 0.4 | V |
| I_q | Quiescent Current | $I_O = 0mA$ | | 0.8 | 2 | mA |
| | | $I_O = 150mA$ | | 25 | 45 | mA |
| | | $I_O = 400mA^*$ | | 65 | 90 | mA |
| $\frac{\Delta V_O}{\Delta T \cdot V_O}$ | Temperature Output Voltage Drift | | | 0.1 | | $\frac{mV}{^\circ C \cdot V}$ |
| SVR | Supply Voltage Rejection | $I_O = 350mA$; $f = 320Hz$; $C_O = 100\mu F$; $V_I = V_O + 3V + 2V_{pp}$ | | 60 | | dB |
| I_O | Max Output Current | | | 800 | | mA |
| I_{sc} | Output Short Circuit Current (fold back condition) | | | 350 | 500 | mA |

* only for L4892 the current test conditions is $I_O = 300mA$

ELECTRICAL CHARACTERISTICS ($V_I = 14.4V$; $C_O = 100\mu F$; $T_j = -40$ to $125^\circ C$ (note 1) unless otherwise specified.)

| Symbol | Parameter | Test Condition | Min. | Typ. | Max. | Unit |
|------------------|--|--------------------------------|-------|-------|-------|------|
| V_O | Output Voltage | $I_O = 5mA$ to 400mA (L4805) | 4.70 | 5.00 | 5.30 | V |
| | | $I_O = 5mA$ to 400mA (L4808) | 7.50 | 8.00 | 8.50 | V |
| | | $I_O = 5mA$ to 400mA (L4810) | 8.00 | 8.50 | 9.00 | V |
| | | $I_O = 5mA$ to 400mA (L4812) | 8.65 | 9.20 | 9.75 | V |
| | | $I_O = 5mA$ to 400mA (L4885) | 9.40 | 10.00 | 10.60 | V |
| | | $I_O = 300mA$ (L4892) | 11.30 | 12.00 | 12.70 | V |
| V_I | Operating Input Voltage | see note 2 | | | 26 | V |
| $\Delta V_O/V_O$ | Line Regulation | $V_I = 14$ to 26V; $I_O = 5mA$ | | 2 | 15 | mV/V |
| $\Delta V_O/V_O$ | Load Regulation | $I_O = 5$ to 400mA* | | 5 | 25 | mV/V |
| $V_I - V_O$ | Dropout Voltage | $I_O = 400mA^*$ | | 0.5 | 0.9 | V |
| | | $I_O = 150mA$ | | 0.25 | 0.5 | V |
| I_q | Quiescent Current | $I_O = 0mA$ | | 1.2 | 3 | mA |
| | | $I_O = 150mA$ | | 40 | 70 | mA |
| | | $I_O = 400mA^*$ | | 80 | 140 | mA |
| I_O | Max Output Current | | | 870 | | mA |
| I_{sc} | Output Short Circuit Current (fold back condition) | | | 230 | | mA |

Notes : 1. This limits are guaranteed by design, correlation and statistical control on production samples over the indicated temperature and supply voltage ranges..

2. For a DC voltage $26V < V_I < 35V$ the device is not operating.

Figure 1: Dropout Voltage vs. Output Current

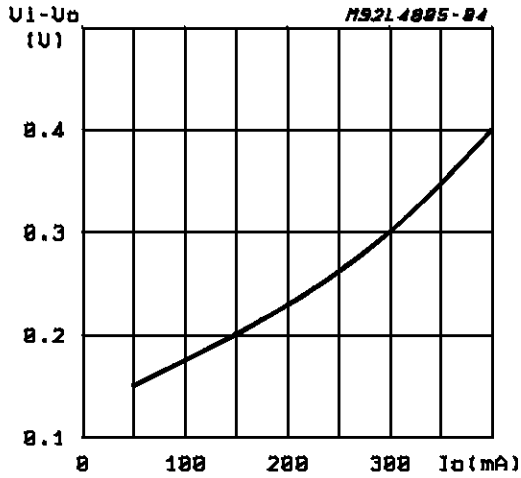

Figure 2: Quiescent Current vs. Output Current

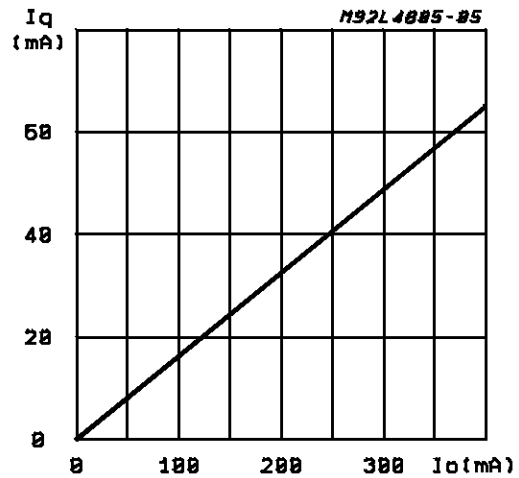

Figure 3: Output Voltage vs. Temperature

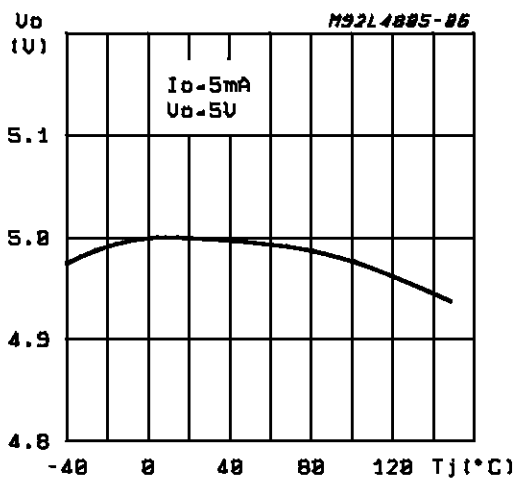

Figure 4: Foldback Current Limiting (L4805)

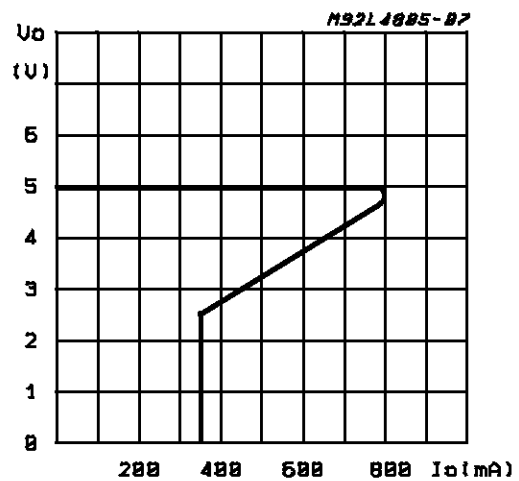
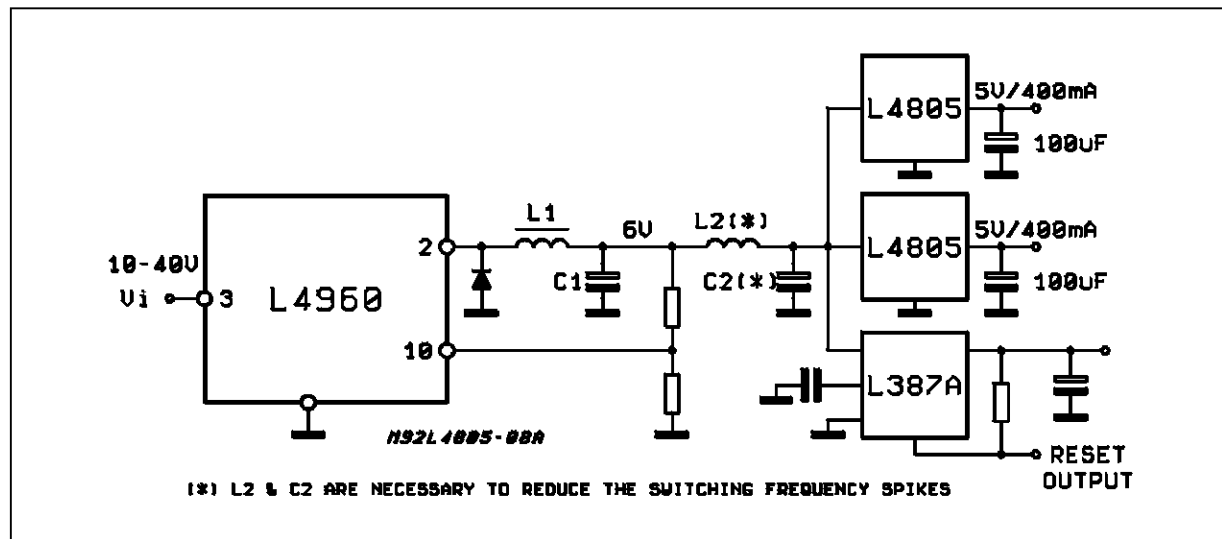
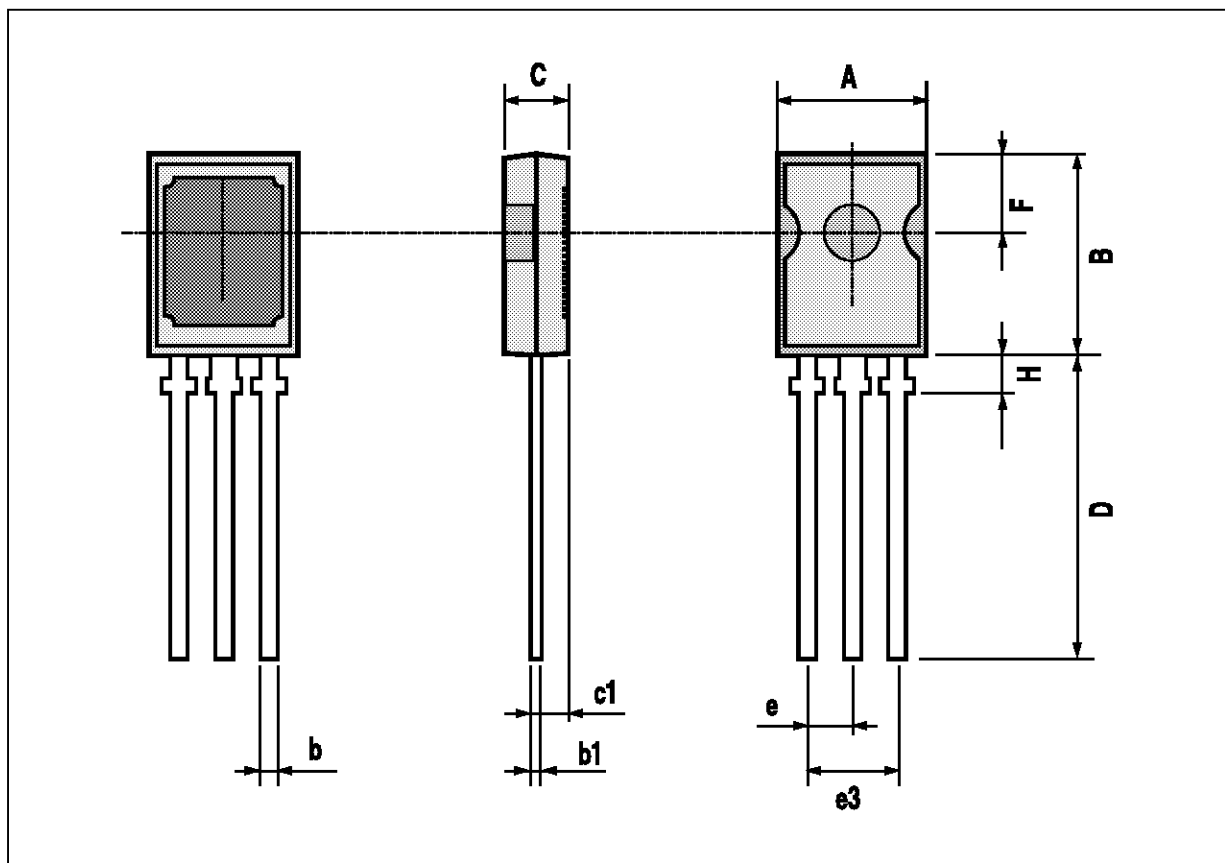

Figure 5: Preregulator for Distributed Supplies



SOT82 PACKAGE MECHANICAL DATA

| DIM. | mm | | | inch | | |
|------|------|------|------|-------|-------|-------|
| | MIN. | TYP. | MAX. | MIN. | TYP. | MAX. |
| A | 7.4 | | 7.8 | 0.291 | | 0.307 |
| B | 10.5 | | 10.8 | 0.413 | | 0.425 |
| b | 0.7 | | 0.9 | 0.028 | | 0.035 |
| b1 | 0.49 | | 0.75 | 0.019 | | 0.030 |
| C | 2.4 | | 2.7 | 0.094 | | 0.106 |
| c1 | | 1.2 | | | 0.047 | |
| D | | 15.7 | | | 0.618 | |
| e | | 2.2 | | | 0.087 | |
| e3 | | 4.4 | | | 0.173 | |
| F | | 3.8 | | | 0.150 | |
| H | | | 2.54 | | | 0.100 |



TO220 PACKAGE MECHANICAL DATA

| DIM. | mm | | | inch | | |
|------|-------|------|------|-------|-------|-------|
| | MIN. | TYP. | MAX. | MIN. | TYP. | MAX. |
| A | | | 4.8 | | | 0.189 |
| C | | | 1.37 | | | 0.054 |
| D | 2.4 | | 2.8 | 0.094 | | 0.110 |
| D1 | 1.2 | | 1.35 | 0.047 | | 0.053 |
| E | 0.35 | | 0.55 | 0.014 | | 0.022 |
| F | 0.8 | | 1.05 | 0.031 | | 0.041 |
| F2 | 1.15 | | 1.4 | 0.045 | | 0.055 |
| G | 4.95 | 5.08 | 5.21 | 0.195 | 0.200 | 0.205 |
| H2 | | | 10.4 | | | 0.409 |
| H3 | 10.05 | | 10.4 | 0.396 | | 0.409 |
| L2 | | 16.2 | | | 0.638 | |
| L3 | 26.3 | 26.7 | 27.1 | 1.035 | 1.051 | 1.067 |
| L5 | 2.6 | | 3 | 0.102 | | 0.118 |
| L6 | 15.1 | | 15.8 | 0.594 | | 0.622 |
| L7 | 6 | | 6.6 | 0.236 | | 0.260 |
| Dia | 3.65 | | 3.85 | 0.144 | | 0.152 |

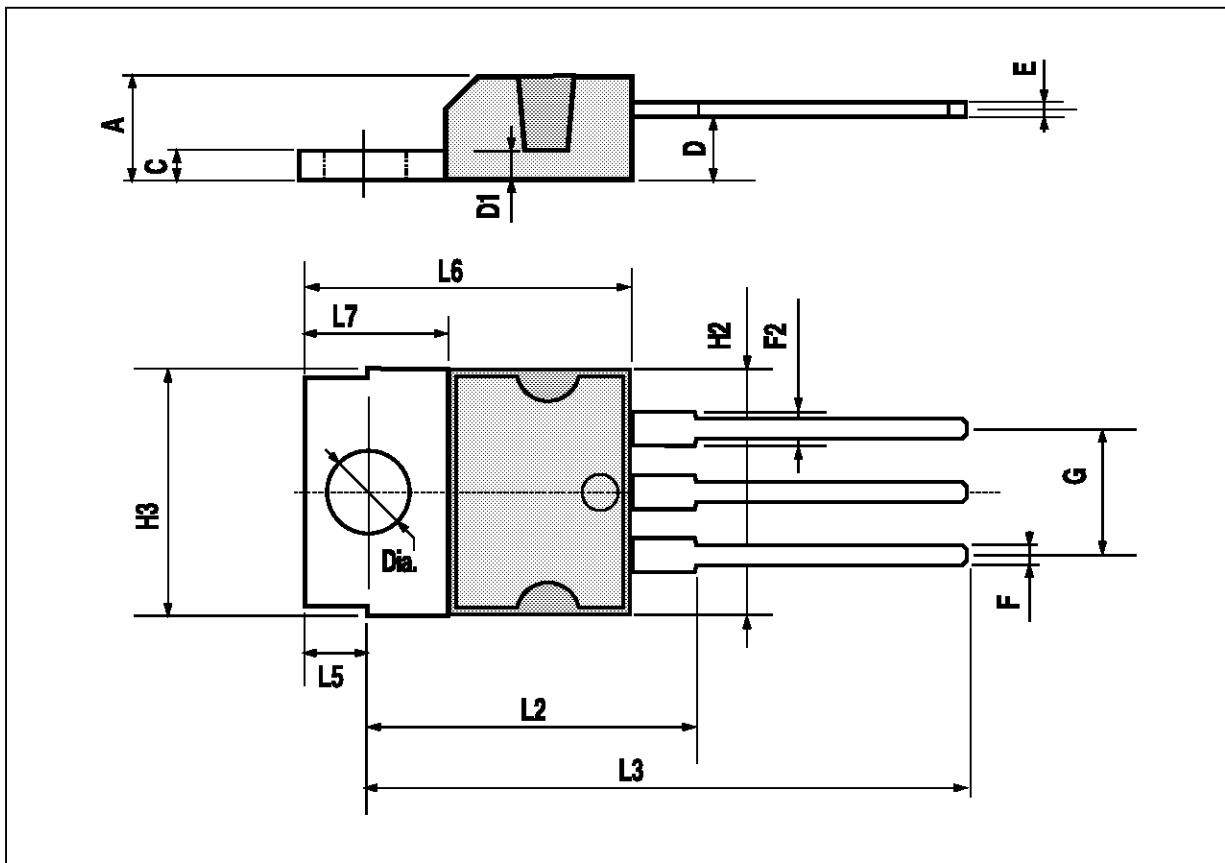

Information furnished is believed to be accurate and reliable. However, SGS-THOMSON Microelectronics assumes no responsibility for the consequences of use of such information nor for any infringement of patents or other rights of third parties which may result from its use. No license is granted by implication or otherwise under any patent or patent rights of SGS-THOMSON Microelectronics. Specifications mentioned in this publication are subject to change without notice. This publication supersedes and replaces all information previously supplied. SGS-THOMSON Microelectronics products are not authorized for use as critical components in life support devices or systems without express written approval of SGS-THOMSON Microelectronics.

© 1994 SGS-THOMSON Microelectronics - All Rights Reserved

SGS-THOMSON Microelectronics GROUP OF COMPANIES

Australia - Brazil - France - Germany - Hong Kong - Italy - Japan - Korea - Malaysia - Malta - Morocco - The Netherlands - Singapore - Spain - Sweden - Switzerland - Taiwan - Thailand - United Kingdom - U.S.A.