

**DUAL 5V REGULATOR
WITH RESET AND DISABLE FUNCTIONS**

PRELIMINARY DATA

- OUTPUT CURRENTS : $I_{O1} = 50\text{mA}$
 $I_{O2} = 100\text{mA}$
- FIXED PRECISION OUTPUT VOLTAGE
 $5\text{V} \pm 2\%$
- RESET FUNCTION CONTROLLED BY INPUT
VOLTAGE AND OUTPUT 1 VOLTAGE
- RESET FUNCTION EXTERNALLY PRO-
GRAMMABLE TIMING
- RESET OUTPUT LEVEL RELATED TO OUT-
PUT 2
- OUTPUT 2 INTERNALLY SWITCHED WITH
ACTIVE DISCHARGING
- OUTPUT 2 DISABLE LOGICAL INPUT
- LOW LEAKAGE CURRENT, LESS THAN $1\mu\text{A}$
AT OUTPUT 1
- INPUT OVERVOLTAGE PROTECTION UP TO
60V
- RESET OUTPUT NORMALLY LOW
- OUTPUT TRANSISTORS SOA PROTECTION
- SHORT CIRCUIT AND THERMAL OVER-
LOAD PROTECTION

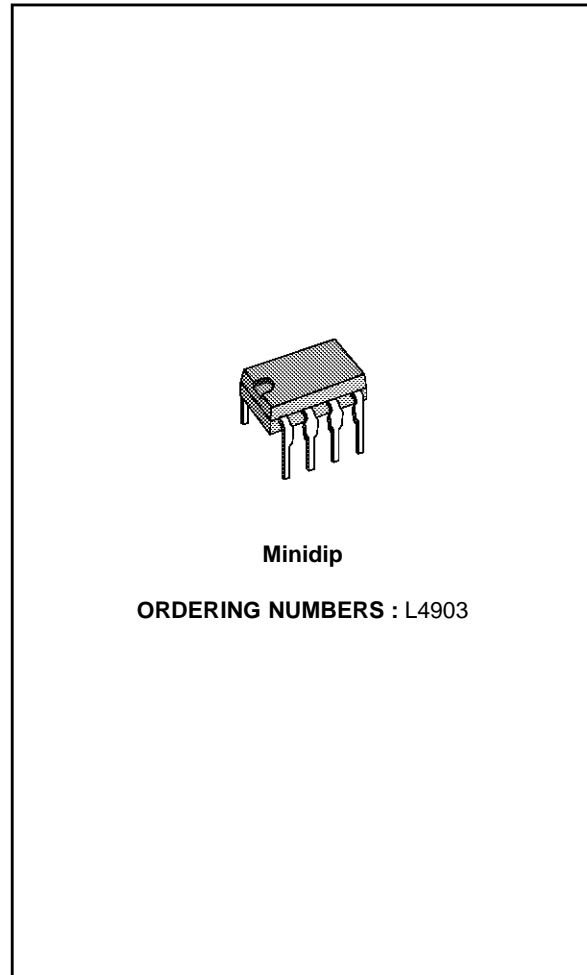

DESCRIPTION

The L4903 is a monolithic low drop dual 5 V regulator designed mainly for supplying microprocessor systems.

Reset, data save functions and remote switch on/off control can be realized.

PIN CONNECTION

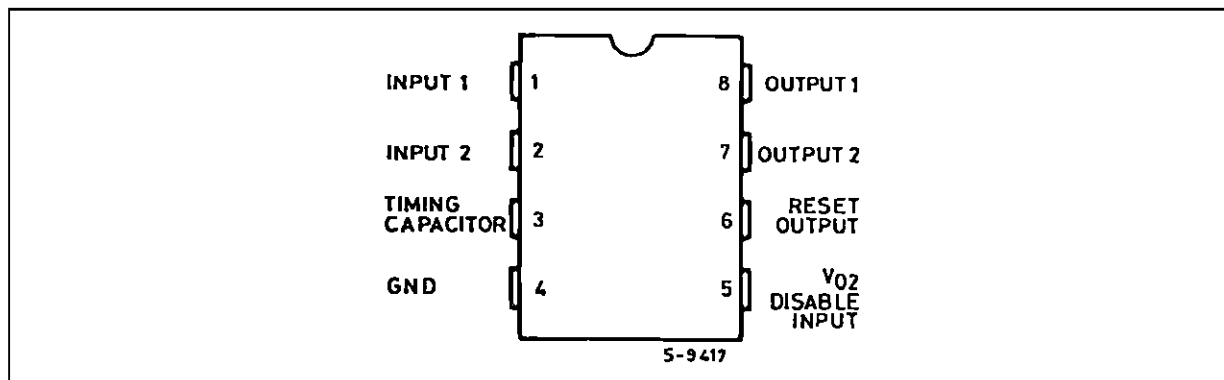

PIN FUNCTIONS

N°	Name	Function
1	Input 1	Low Quiescent Current 50mA Regulator Input
2	Input 2	100mA Regulator Input.
3	Timing Capacitor	If Reg. 2 is switched-ON the delay capacitor is charged with a 10µA constant current. When Reg. 2 is switched-OFF the delay capacitor is discharged.
4	GND	Common Ground
5	Disable Input	A high level (> V _{DT}) disables output Reg. 2.
6	Reset Output	When pin 3 reaches 5V the reset output is switched low. Therefore $t_{RD} = C_t \left(\frac{5V}{10\mu A} \right)$; $t_{RD} \text{ (ms)} = C_t \text{ (nF)}$.
7	Output 2	5V – 100mA Regulator Output. Enabled if V _{o1} > V _{RT} . DISABLE INPUT < V _{DT} and V _{IN2} > V _{IT} . If Reg. 2 is switched-OFF the C _{O2} capacitor is discharged.
8	Output 1	5V – 50mA regulator output with low leakage in switch-OFF condition.

BLOCK DIAGRAM

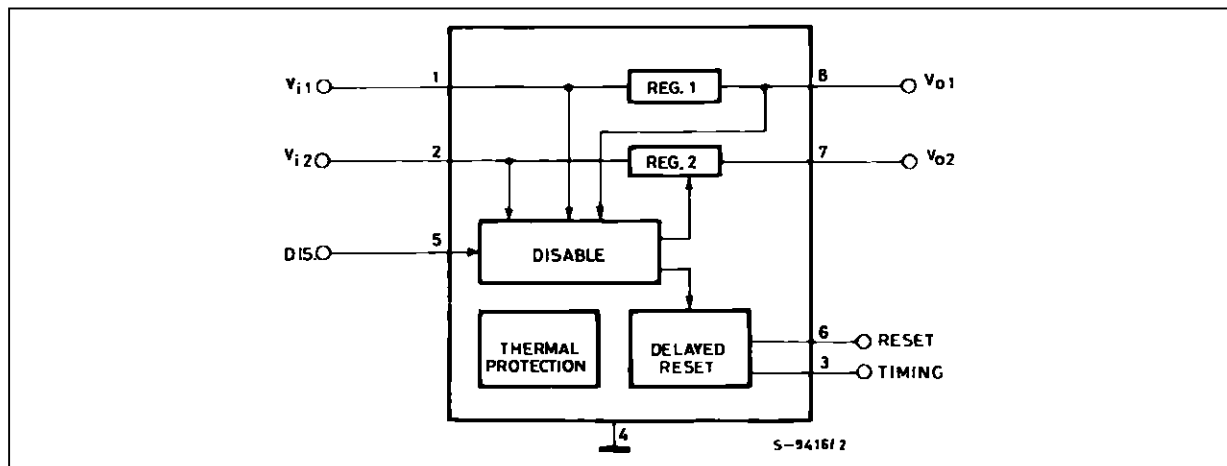

SCHEMATIC DIAGRAM

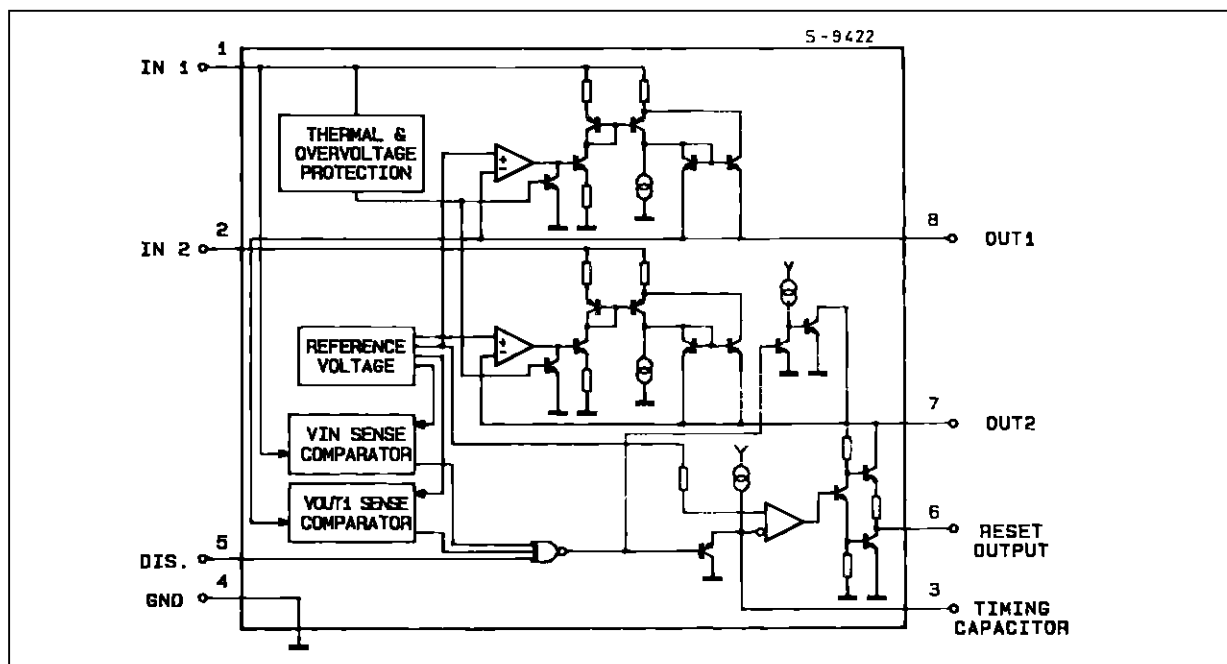

ABSOLUTE MAXIMUM RATINGS

Symbol	Parameter	Value	Unit
V_{IN}	DC Input Voltage	24	V
V_t	Transient Input Overvoltage (t = 40ms)	60	V
P_{tot}	Power Dissipation at $T_{amb} = 50^\circ\text{C}$	1	W
T_{stg}, T_j	Storage and Junction Temperature	- 40 to 150	$^\circ\text{C}$

THERMAL DATA

Symbol	Parameter	Value	Unit
$R_{th(j-pin)}$	Thermal Resistance Junction-pin 4 Max.	70	$^\circ\text{C/W}$
$R_{th(j-a)}$	Thermal Resistance Junction-ambient Max.	100	$^\circ\text{C/W}$

ELECTRICAL CHARACTERISTICS ($V_{IN} = 14.4\text{V}$, $T_{amb} = 25^\circ\text{C}$ unless otherwise specified)

Symbol	Parameter	Test Conditions	Min.	Typ.	Max.	Unit
V_i	DC Operating Input Voltage				20	V
V_{O1}	Output Voltage 1	R Load 1k Ω	4.95	5.05	5.15	V
V_{O2H}	Output Voltage 2 HIGH	R Load 1k Ω	$V_{O1} - 0.1$	5	V_{O1}	V
V_{O2L}	Output Voltage 2 LOW	$I_{O2} = -5\text{mA}$		0.1		V
I_{O1}	Output Current 1 max. (*)	$\Delta V_{O1} = -100\text{mV}$	50			mA
I_{LO1}	Leakage Output 1 Current	$V_{IN} = 0, V_{O1} \leq 3\text{V}$			1	μA
I_{O2}	Output Current 2 max. (*)	$\Delta V_{O2} = -100\text{mV}$	100			mA
V_{IO1}	Output 1 Dropout Voltage (*)	$I_{O1} = 10\text{mA}$ $I_{O1} = 50\text{mA}$		0.7 0.75	0.8 0.9	V V
V_{IT}	Input Threshold Voltage		$V_{O1} + 1.2$	6.4	$V_{O1} + 1.7$	V
V_{ITH}	Input Threshold Voltage Hyst.			250		mV
ΔV_{O1}	Line Regulation 1	$7\text{V} < V_{IN} < 18\text{V}, I_{O1} = 5\text{mA}$		5	50	mV
ΔV_{O2}	Line Regulation 2	$7\text{V} < V_{IN} < 18\text{V}, I_{O2} = 5\text{mA}$		5	50	mV
ΔV_{O1}	Load Regulation 1	$V_{IN1} = 8\text{V}, 5\text{mA} < I_{O1} < 50\text{mA}$		5	20	mV
ΔV_{O2}	Load Regulation 2	$V_{IN1} = 8\text{V}, 5\text{mA} < I_{O2} < 100\text{mA}$		10	50	mV
I_Q	Quiescent Current	$I_{O1} = I_{O2} \leq 5\text{mA}$ $0 < V_{IN} < 13\text{V}$ $7\text{V} < V_{IN} < 13\text{V} V_{O2} \text{ LOW}$ $7\text{V} < V_{IN} < 13\text{V} V_{O2} \text{ HIGH}$		4.5 2.7 1.6	6.5 4.5 3.5	mA
I_{Q1}	Quiescent Current 1	$6.3\text{V} < V_{IN1} < 13\text{V}, V_{IN2} = 0$ $I_{O1} \leq 5\text{mA}, I_{O2} = 0$		0.6	0.9	mA
V_{RT}	Reset Threshold Voltage		$V_{O2} - 0.04$	4.7	$V_{O2} - 0.02$	V
V_{RTH}	Reset Threshold Hysteresis		30	50	80	mV
V_{RH}	Reset Output Voltage HIGH	$I_R = 500\mu\text{A}$	$V_{O2} - 1$	4.12	V_{O2}	V
V_{RL}	Reset Output Voltage LOW	$I_R = -5\text{mA}$		0.25	0.4	V
t_{RD}	Reset Pulse Delay	$C_t = 10\text{nF}$	3	5	11	ms
t_d	Timing Capacitor Discharge Time	$C_t = 10\text{nF}$			20	μs
V_{DT}	V_{O2} Disable Threshold Voltage			1.25	2.4	V
I_D	V_{O2} Disable Input Current	$V_D \leq 0.4\text{V}$ $V_D \geq 2.4\text{V}$		-150 30		μA μA
$\frac{\Delta V_{O1}}{\Delta T}, \frac{\Delta V_{O2}}{\Delta T}$	Thermal Drift	$-20^\circ\text{C} \leq T_{amb} \leq 125^\circ\text{C}$		0.3 -0.8		$\text{mV}/^\circ\text{C}$
SVR1	Supply Voltage Rejection	f = 100Hz, $V_R = 0.5\text{V}, I_o = 50\text{mA}$	50	84		dB
SVR2	Supply Voltage Rejection	f = 100Hz, $V_R = 0.5\text{V}, I_o = 100\text{mA}$	50	80		dB
T_{JSD}	Thermal Shut Down			150		$^\circ\text{C}$

* The dropout voltage is defined as the difference between the input and the output voltage when the output voltage is lowered of 25 mV under constant output current condition.

TEST CIRCUIT

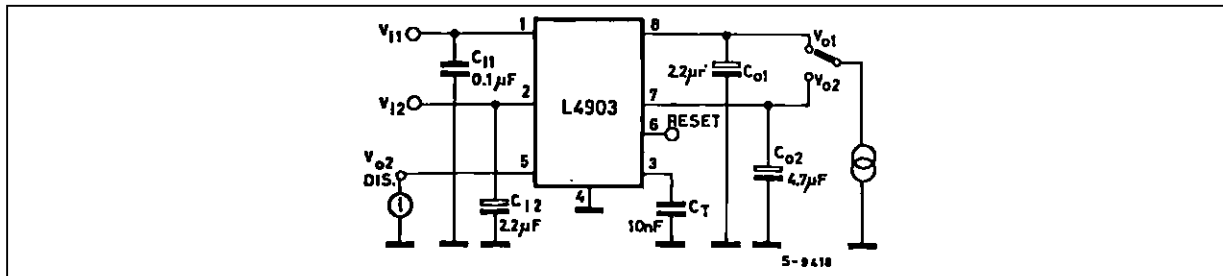
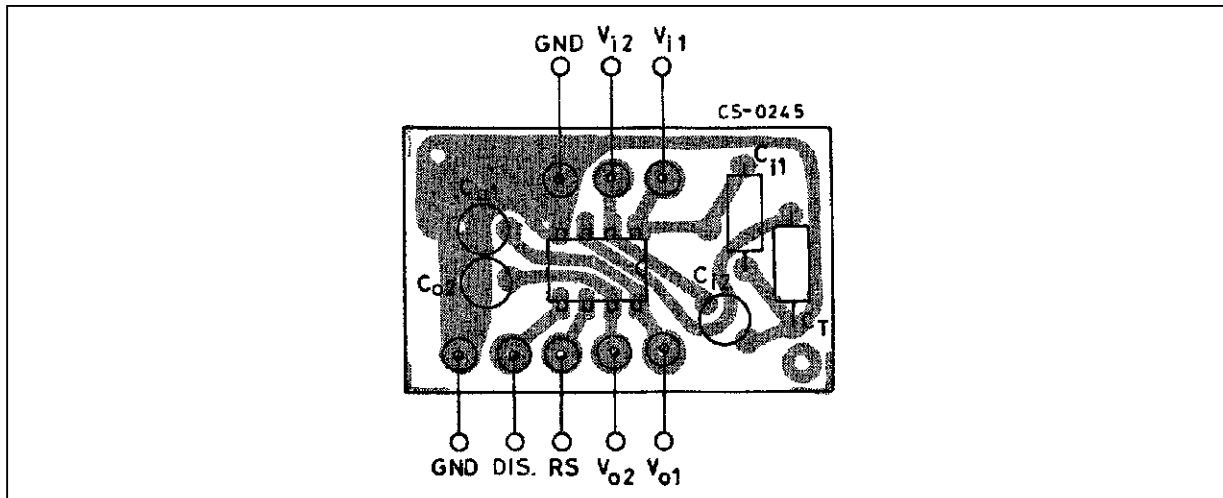

Figure 1 : P.C. Board and Components Layout of the Test Circuit



APPLICATION INFORMATION

In power supplies for μ P systems it is necessary to provide power continuously to avoid loss of information in memories and in time of day clocks, or to save data when the primary supply is removed. The L4903 makes it very easy to supply such equipments ; it provides two voltage regulators (both 5 V high precision) with separate inputs plus a reset output for the data save function and Reg. 2 disable input.

CIRCUIT OPERATION (see Figure 2)

After switch on Reg. 1 saturates until V_{01} rises to the nominal value.

When the input 2 reaches V_{IT} and the output 1 is higher than V_{RT} the output 2 (V_{02} and V_R) switches on and the reset output (V_R) goes low after a programmable time T_{RD} (timing capacitor).

V_{02} is switched at low level and V_R at high level when one of the following conditions occurs ;

- a high level ($> V_{DT}$) is applied on pin 5 ;
- an input overvoltage ;
- an overload on the output 1 ($V_{01} < V_{RT}$) ;
- a switch off ($V_{IN} < V_{IT} - V_{ITH}$) ;

and they start again as before when the condition

is removed.

An overload on output 2 does not switch Reg. 2, and does not influence Reg. 1.

The V_{01} output features :

- 5 V internal reference without voltage divider between the output and the error comparator
- very low drop series regulator element utilizing current mirrors

permit high output impedance and then very low leakage current even in power conditions.

This output may therefore be used to supply circuits continuously, such as volatile RAMs, allowing the use of a back-up battery.

The V_{02} can supply other non essential 5 V circuits which may be powered down when the system is inactive, or that must be powered down to prevent uncorrect operation for supply voltages below the minimum value.

The reset output can be used as a "POWER DOWN INTERRUPT", permitting RAM access only in correct power conditions, or as a "BACK-UP ENABLE" to transfer data into in a NV SHADOW MEMORY when the supply is interrupted.

The disable function can be used for remote on/off control of circuits connected to the V_{02} output.

Figure 2

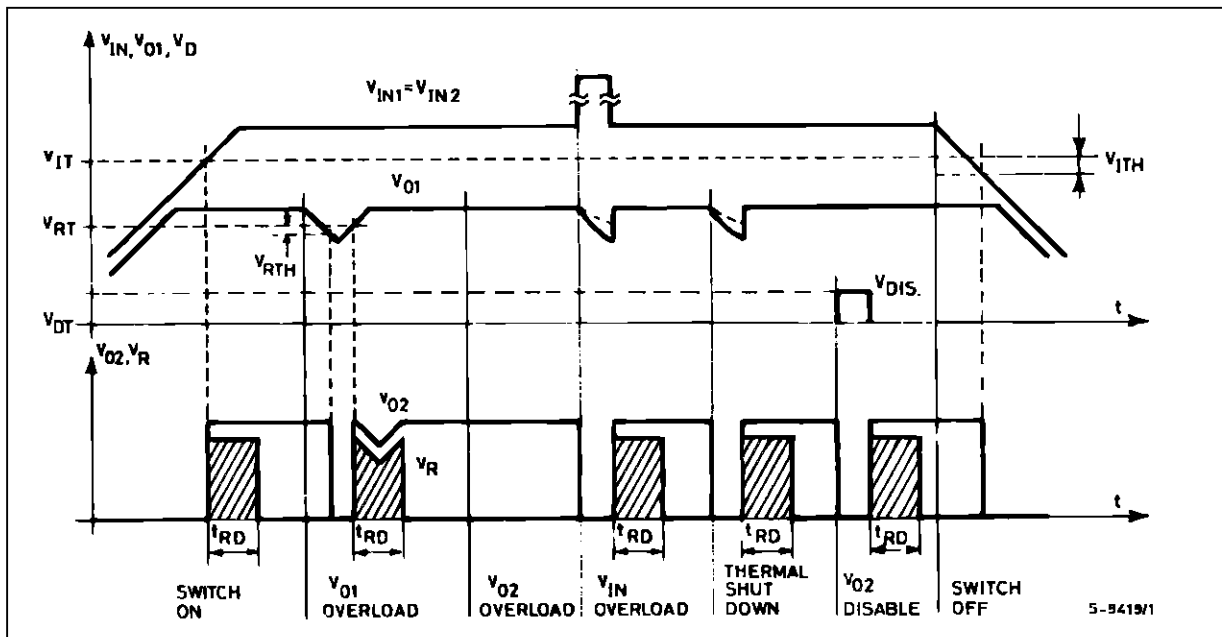

APPLICATION SUGGESTION

Figure 3 illustrates how the L4903's disable input may be used in a CMOS μ Computer application. The V_{01} regulator (low consumption) supply permanently a CMOS time of day clock and a CMOS computer chip with volatile memory. V_{02} output,

supplying non-essential circuits, is turned OFF under control of a μ P unit.

Configurations of this type are used in products where the OFF switch is part of a keyboard scanned by a micro which operates continuously even in the OFF state.

Figure 3

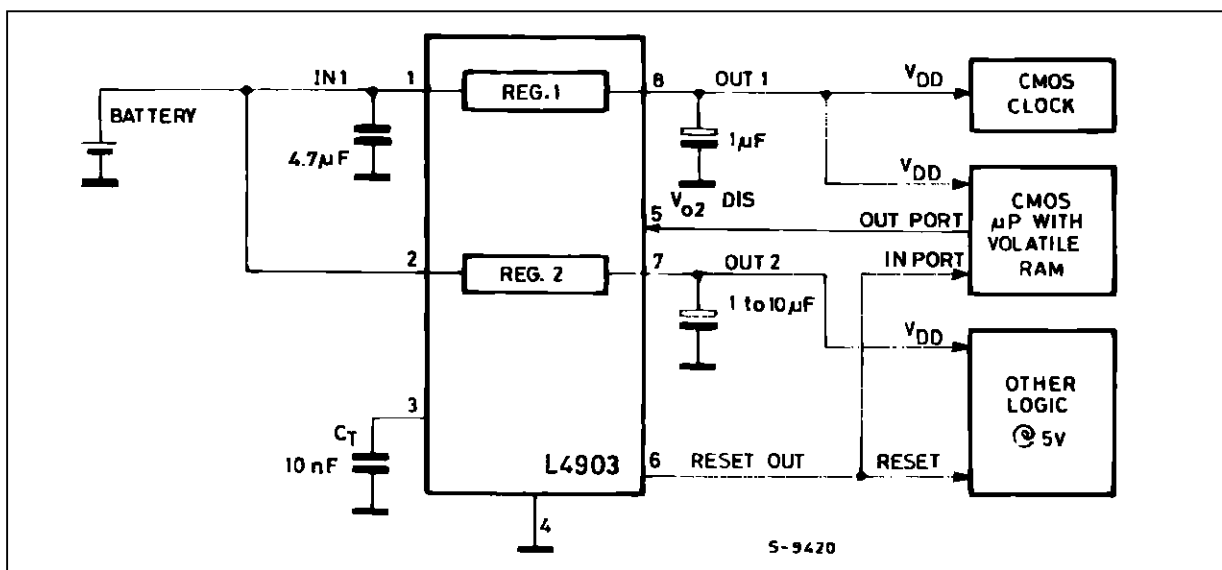

Figure 4 : Quiescent Current (reg. 1) versus Output Current

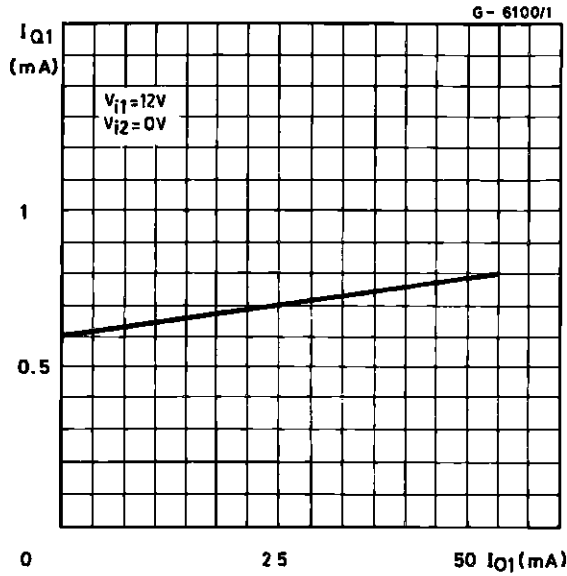

Figure 5 : Quiescent Current (reg. 1) versus Input Voltage

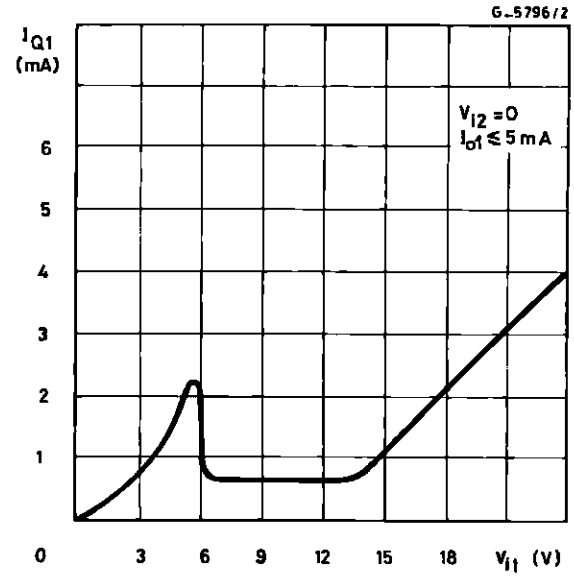

Figure 6 : Total Quiescent Current versus Input Voltage

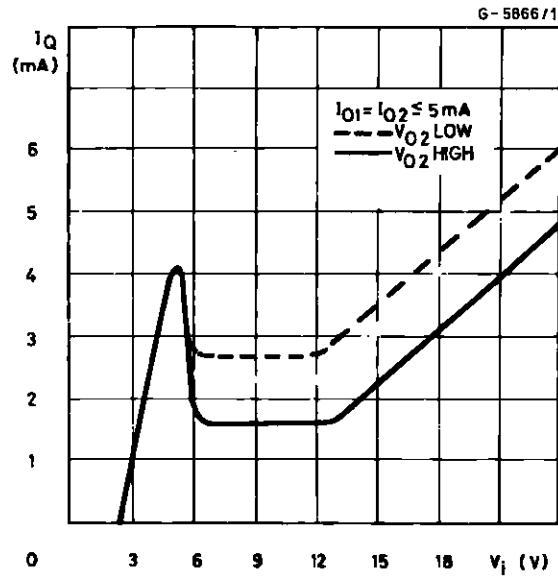
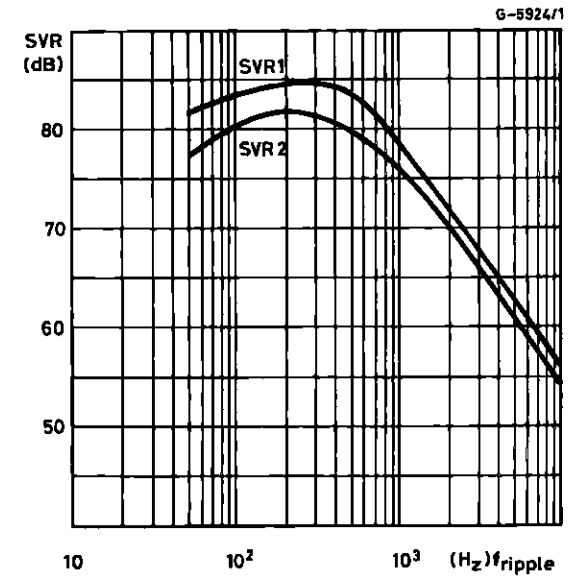
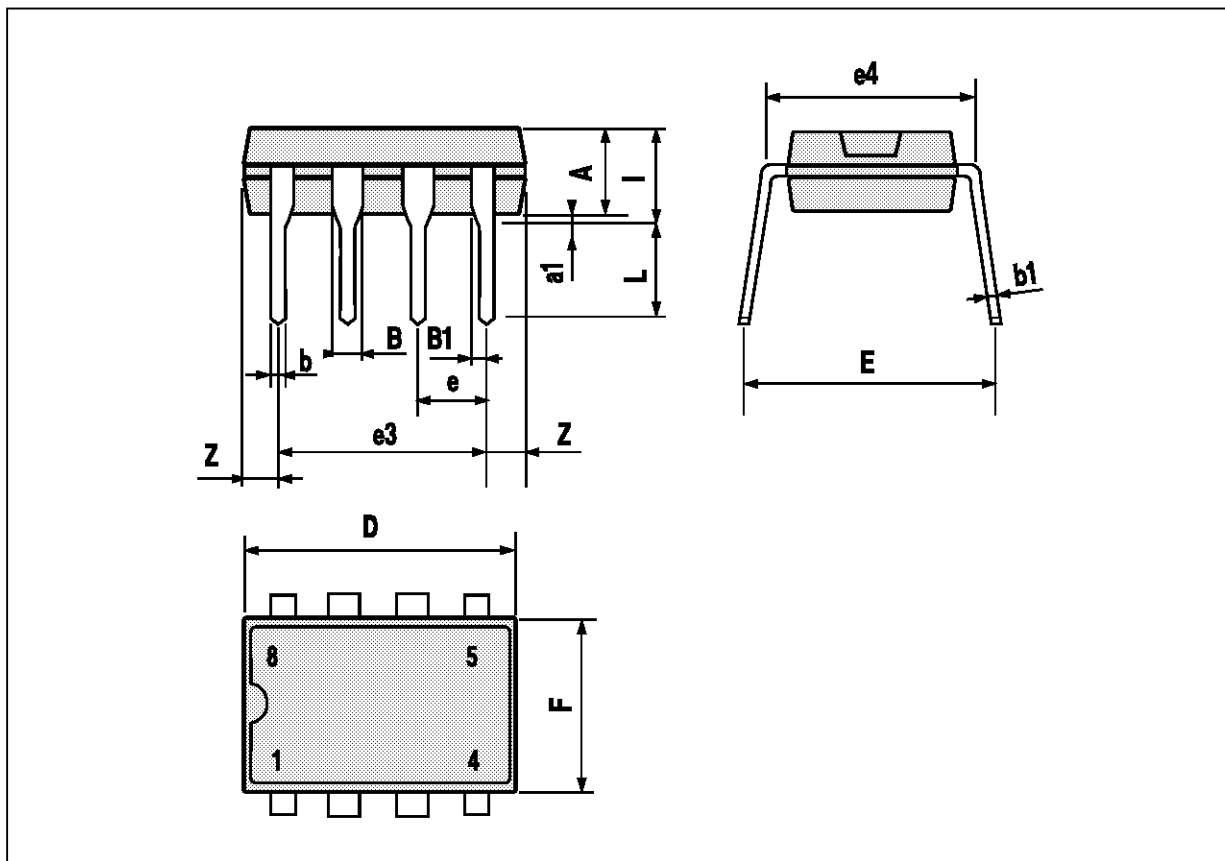

Figure 7 : Supply Voltage Rejection Regulators 1 and 2 versus Input Ripple Frequency



MINIDIP PACKAGE MECHANICAL DATA

DIM.	mm			inch		
	MIN.	TYP.	MAX.	MIN.	TYP.	MAX.
A		3.32			0.131	
a1	0.51			0.020		
B	1.15		1.65	0.045		0.065
b	0.356		0.55	0.014		0.022
b1	0.204		0.304	0.008		0.012
D			10.92			0.430
E	7.95		9.75	0.313		0.384
e		2.54			0.100	
e3		7.62			0.300	
e4		7.62			0.300	
F			6.6			0.260
I			5.08			0.200
L	3.18		3.81	0.125		0.150
Z			1.52			0.060



Information furnished is believed to be accurate and reliable. However, SGS-THOMSON Microelectronics assumes no responsibility for the consequences of use of such information nor for any infringement of patents or other rights of third parties which may result from its use. No license is granted by implication or otherwise under any patent or patent rights of SGS-THOMSON Microelectronics. Specifications mentioned in this publication are subject to change without notice. This publication supersedes and replaces all information previously supplied. SGS-THOMSON Microelectronics products are not authorized for use as critical components in life support devices or systems without express written approval of SGS-THOMSON Microelectronics.

© 1994 SGS-THOMSON Microelectronics - All Rights Reserved

SGS-THOMSON Microelectronics GROUP OF COMPANIES

Australia - Brazil - France - Germany - Hong Kong - Italy - Japan - Korea - Malaysia - Malta - Morocco - The Netherlands - Singapore - Spain - Sweden - Switzerland - Taiwan - Thailand - United Kingdom - U.S.A.