

DUAL MULTIFUNCTION VOLTAGE REGULATOR

ADVANCE DATA

- STANDBY OUTPUT VOLTAGE PRECISION $5V \pm 2\%$
- OUTPUT 2 TRACKED TO THE STANDBY OUTPUT
- OUTPUT 2 DISABLE FUNCTION FOR STANDBY MODE
- VERY LOW QUIESCENT CURRENT, LESS THAN $250\mu A$, IN STANDBY MODE
- OUTPUT 2 VOLTAGE SETTABLE FROM 5 TO 20V
- OUTPUT CURRENTS : $I_{O1} = 50mA$, $I_{O2} = 500mA$
- VERY LOW DROPOUT (max 0.4V/0.6V)
- OPERATING TRANSIENT SUPPLY VOLTAGE UP TO 40V
- POWER-ON RESET CIRCUIT SENSING THE STANDBY OUTPUT VOLTAGE
- POWER-ON RESET DELAY PULSE DEFINED BY THE EXTERNAL CAPACITOR
- EARLY WARNING OUTPUT FOR SUPPLY UNDERVOLTAGE
- THERMAL SHUTDOWN AND SHORT CIRCUIT PROTECTIONS

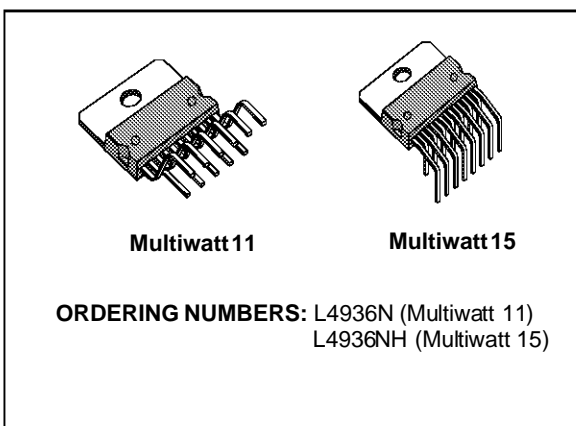

DESCRIPTION

The L4936N/NH are monolithic integrated dual voltage regulators with two very low dropout outputs and additional functions such as power-on reset and input voltage sense. They are designed for supplying microcomputer controlled systems specially in automotive applications.

PIN CONNECTION (top view)

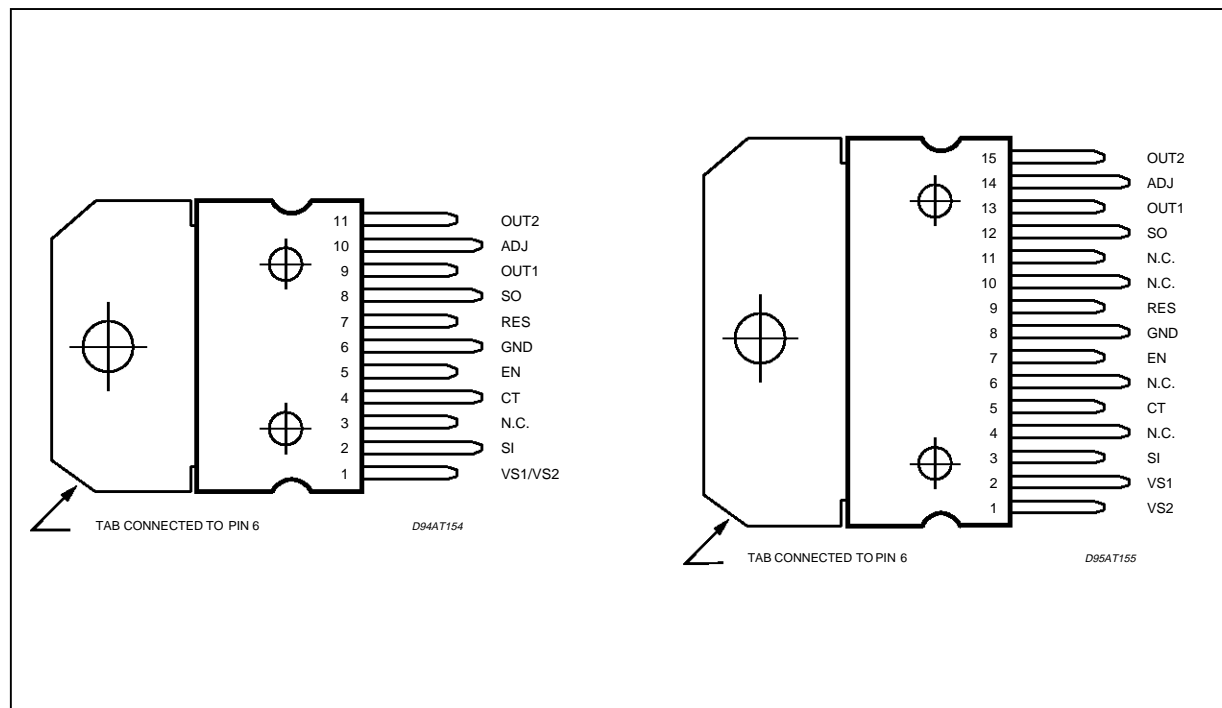

BLOCK DIAGRAM

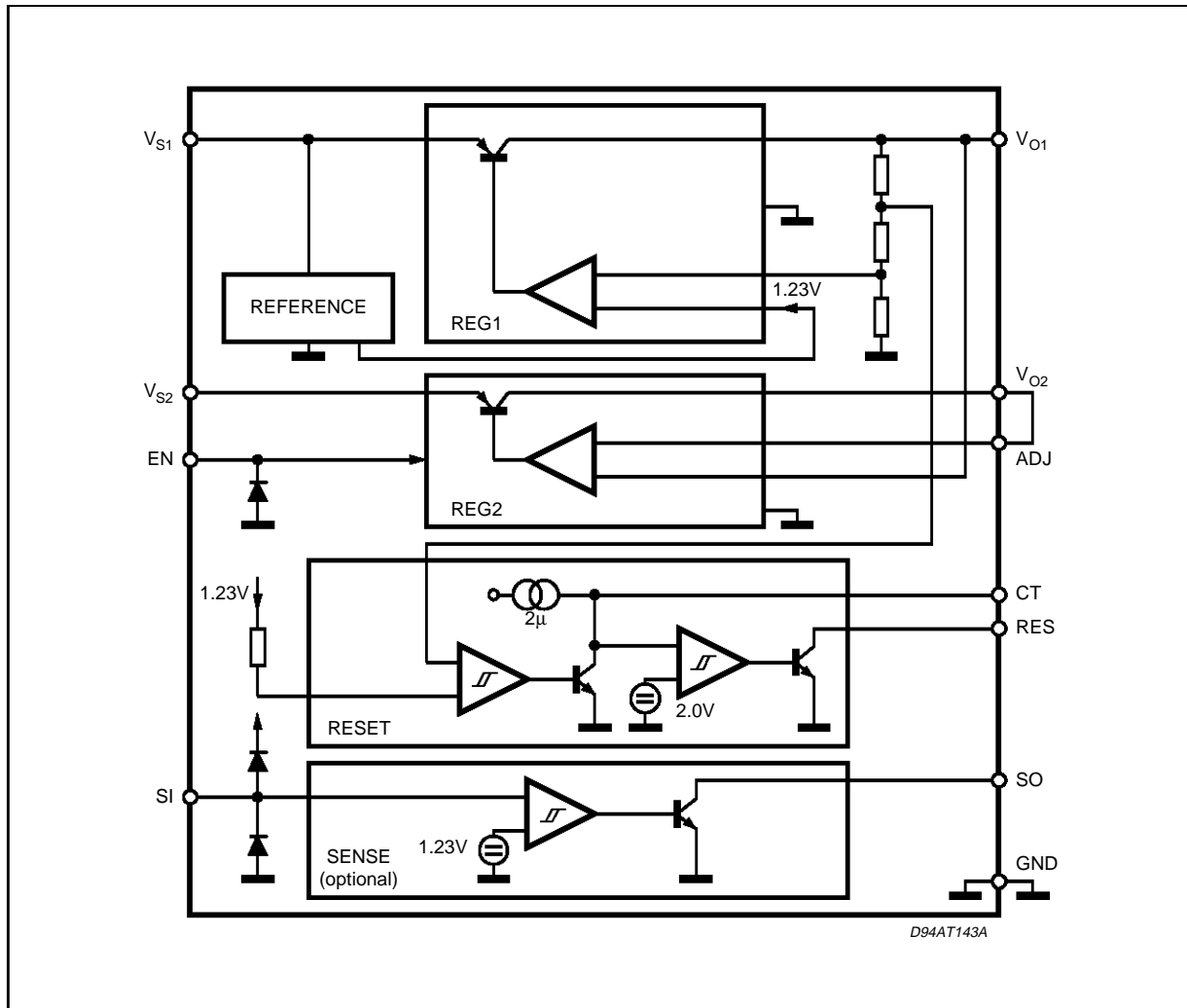

THERMAL DATA

Symbol	Parameter	Value	Unit
R _{thj-case}	Thermal Resistance Junction-Case	Max. 3	°C/W

Note: VS1, VS2, SI pins are rated at 1500V versus positive ESD according to human body model; other pins are rated at 2000V.

ABSOLUTE MAXIMUM RATINGS

Symbol	Parameter	Value	Unit
V_S	DC Supply Voltage	28	V
	Transient Supply Voltage ($T < 1s$)	40	V
T_j, T_{stg}	Junction and Storage Temperature Range	-55 to 150	°C
I_{SI}	Sense Input Current ($V_{SI} \leq 0.3V$ or $V_{SI} > V_S$)	± 1	mA
I_{EN}	Enable Input Current ($V_{EN} \leq 0.3V$)	-1	mA
V_{EN}	Enable Input Voltage	V_S	
V_{RES}, V_{SO}	Reset and Sense Output Voltage	20	V
I_{RES}, I_{SO}	Reset and Sense Output Current	5	mA
P_D	Power Dissipation ($T_A = 80^\circ C, R_{th \text{ heatsink}} = 11^\circ C/W$) MW11 POWERDIP	5	W
		1166	mW

Note : The circuit is ESD protected according to MIL-STD-883C.

APPLICATION CIRCUIT

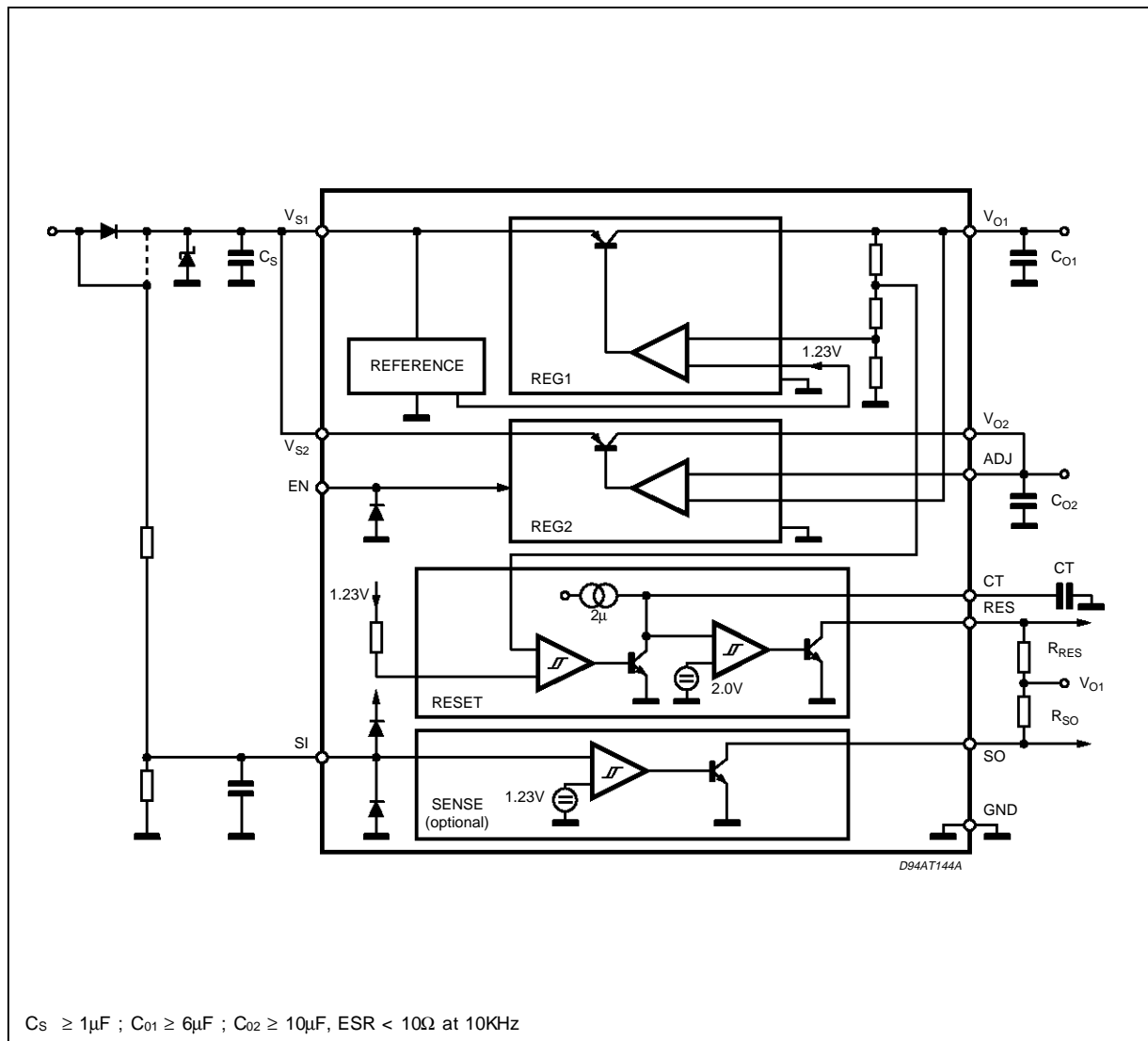

ELECTRICAL CHARACTERISTICS ($V_S = 14V$; $-40^\circ C$ unless otherwise specified)

Symbol	Parameter	Test Conditions	Min.	Typ.	Max.	Unit
V_S	Operating Supply Voltage				25	V
V_{O1}	Standby Output Voltage	$6V \leq V_S \leq 25V$ $1mA \leq I_{O1} \leq 50mA$	4.90	5.00	5.10	V
$V_{O2} - V_{O1}$	Output Voltage 2 Tracking Error (note 1)	$6V \leq V_S \leq 25V$ $5mA \leq I_{O2} \leq 500mA$ Enable = LOW	-25		+25	mV
I_{ADJ}	ADJ Input Current	$I_{O1} = 1mA$; $I_{O2} = 5mA$	-1	0.1	1	μA
V_{DP1}	Dropout Voltage 1	$I_{O1} = 10mA$ $I_{O1} = 50mA$		0.1 0.2	0.25 0.4	V
V_{IO1}	Input to Output Voltage Difference in Undervoltage Condition	$V_S = 4V$, $I_{O1} = 35mA$			0.4	V
V_{DP2}	Dropout Voltage 2	$I_{O1} = 100mA$ $I_{O1} = 500mA$		0.2 0.3	0.3 0.6	V
V_{IO2}	Input to Output Voltage Difference in Undervoltage Condition	$V_S = 4.6V$, $I_{O1} = 350mA$			0.6	V
$V_{OL\ 1.2}$	Line Regulation	$6V \leq V_S \leq 25V$ $I_{O2} = 1mA$; $I_{O2} = 5mA$			20	mV
V_{OLO1}	Load Regulation 1	$1mA \leq I_{O1} \leq 50mA$			25	mV
V_{OLO2}	Load Regulation 2	$5mA \leq I_{O2} \leq 500mA$			50	mV
I_{LIM1}	Current Limit 1	$V_{O1} = 4.5V$ $V_{O1} = 0V$ (note 2)	55 25	100 50	200 100	mA mA
I_{LIM2}	Current Limit 2	$V_{O2} = 0V$	550	1000	1700	mA
I_{QSB}	Quiescent Current Standby Mode (output 2 disabled)	$I_{O1} = 0.3mA$; $T_J < 100^\circ C$ $V_{EN} \geq 2.4V$ $V_S = 14V$ $V_S = 3.5V$		210 340	290 850	μA μA
I_Q	Quiescent Current	$I_{O1} = 50mA$ $I_{O1} = 500mA$			30	mA

ENABLE

V_{ENL}	Enable Input LOW Voltage (output 2 active)		-0.3		1.5	V
V_{ENH}	Enable Input HIGH Voltage		2.4		7	V
V_{ENhyst}	Enable Hysteresis		30	75	200	mV
I_{EN}	Enable Input Current	$0V < V_{EN} < 1.2V$ $2.5V < V_{EN} < 7V$	-10 -1	-1.5 0	-0.5 +1	μA μA

ELECTRICAL CHARACTERISTICS (continued)**RESET**

Symbol	Parameter	Test Conditions	Min.	Typ.	Max.	Unit
V_{Rt}	Reset Low Threshold Voltage	$V_S = 14V$	$V_{O1} - 0.4$	4.7	$V_{O1} - 0.1$	V
V_{Rth}	Reset Threshold Hysteresis		50	100	200	mV
t_{RD}	Reset Pulse Delay	$C_T = 100nF$; $t_R > 100\mu s$	55	100	180	mV
t_{RR}	Reset Reaction Time	$C_T = 100nF$	1	0	50	μs
V_{RL}	Reset Output LOW Voltage	$R_{RES} = 10K\Omega$ to V_{O1} $V_S = 1.5V$			0.4	V
I_{LRES}	Reset Output HIGH Leakage	$V_{RES} = 5V$			1	μA
V_{CTh}	Delay Comparator Threshold			2.0		V
$V_{CTh, hyst}$	Delay Comparator Threshold Hysteresis			100		mV

SENSE

V_{Sth}	Sense Threshold Voltage		1.16	1.23	1.35	V
$V_{Sth, hyst}$	Sense Threshold Hysteresis		20	100	200	mV
V_{SOL}	Sense Output LOW Voltage	$V_{SI} = 0.8V$; $V_S \geq 3V$ $R_{SO} = 10K\Omega$ to V_{O1}			0.4	V
I_{LSO}	Sense Output Leakage	$V_{SO} = 5V$; $V_{SI} \geq 1.5V$			1	μA

Note : 1 : V_{O2} connected to ADJ. V_{O2} can be set to higher values by inserting an external resistor divider.
2 : Foldback characteristic

FUNCTIONAL DESCRIPTION

The L4936N/NH are based on the SGS-THOMSON Microelectronics modular voltage regulator approach. Several out-standing features and auxiliary functions are provided to meet the requirements of supplying the microprocessor systems used in automotive applications.

Furthermore the device is suitable also in other applications requiring two stabilized voltages.

The modular approach allows other features and functions to be realized easily when required.

STANDBY REGULATOR

The standby regulator uses an Isolated Collector Vertical PNP transistor as the regulating element. This structure allows a very low dropout voltage at currents up to 50mA. The dropout operation of the standby regulator is maintained down to 2V input supply voltage. The output voltage is regulated up to the transient input supply voltage of 40V. This feature avoids functional interruptions which could be generated by overvoltage pulses.

The typical curve of the standby output voltage as a function of the input supply voltage is shown in fig. 1.

The current consumption of the device (quiescent current) is less than 250 μA when output 2 is disabled (standby mode). The dropout voltage is controlled to reduce the quiescent current peak in the undervoltage region and to improve the transient response in this region.

The quiescent current is shown in fig. 2 as a function of the supply input voltage 2.

OUTPUT 2 VOLTAGE

The output 2 regulator uses the same output structure as the standby regulator, but rated for an output current of 500mA.

The output 2 regulator works in tracking mode with the standby output voltage as a reference voltage when the output 2 programming pin ADJ is connected to V_{O2} . By connecting a resistor divider R_1 , R_2 to the pin ADJ as shown in fig. 3, the output voltage 2 can be programmed to the value :

$$V_{O2} = V_{O1} (1 + R_1/R_2)$$

The output 2 regulator can be switched off via the Enable input.

Figure 1 : Output Voltage vs. Input Voltage.

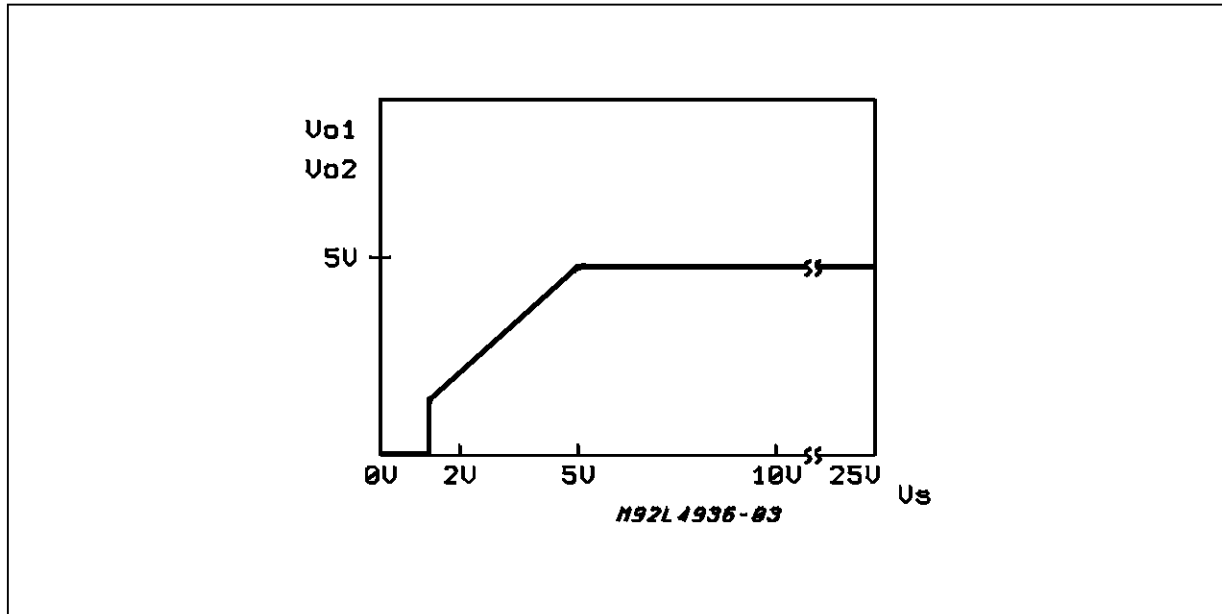

Figure 2 : Quiescent Current vs. Supply Voltage.

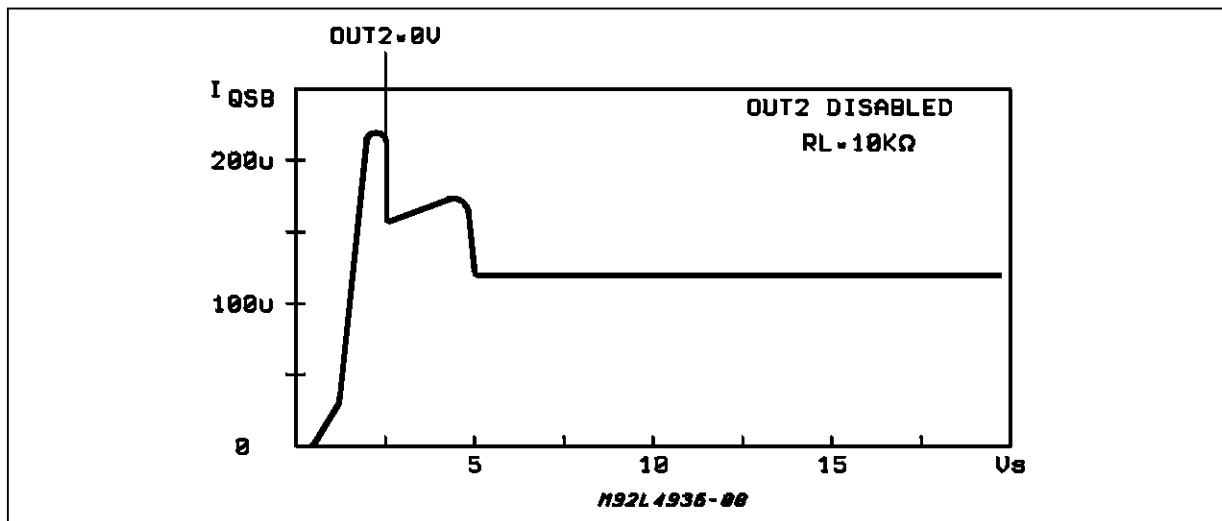
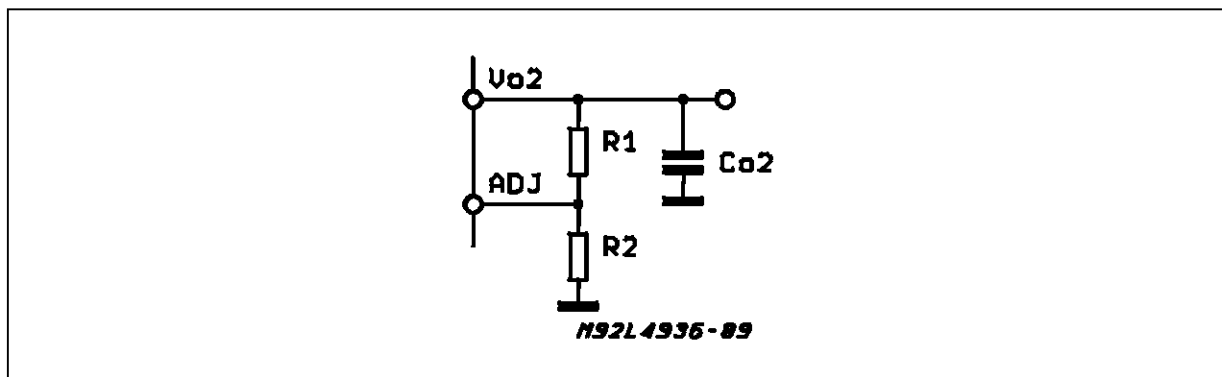

Figure 3 : Programmable Output 2 Voltage with External Resistors.



RESET CIRCUIT

The block circuit diagram of the reset circuit is shown in fig. 4. The reset circuit supervises the standby output voltage. The reset threshold of 4.7V is defined by the internal reference voltage and the standby output divider.

The reset pulse delay time t_{RD} , is defined by the charge time of an external capacitor C_T :

$$t_{RD} = \frac{C_T \times 2V}{2\mu A}$$

The reaction time of the reset circuit depends on the discharge time limitation of the reset capacitor C_T and is proportional to the value of C_T .

The reaction time of the reset circuit increases the noise immunity. In fact, if the standby output voltage

drops below the reset threshold for a time shorter than the reaction time t_{RR} , no reset output variation occurs. The nominal reset delay is generated for standby output voltage drops longer than the time necessary for the complete discharging of the capacitor C_T . This time is typically equal to 50 μ s if $C_T = 100$ nF. The typical reset output waveforms are shown in fig. 5.

SENSE COMPARATOR

This circuit compares an input signal with an internal voltage reference of typically 1.23V. The use of an external voltage divider makes the comparator very flexible in the application. This function can be used to supervise the input voltage - either before or after the protection diode - and to give additional information to the microprocessor such as low voltage warnings.

Figure 4 :Block Diagram of the Reset Circuit.

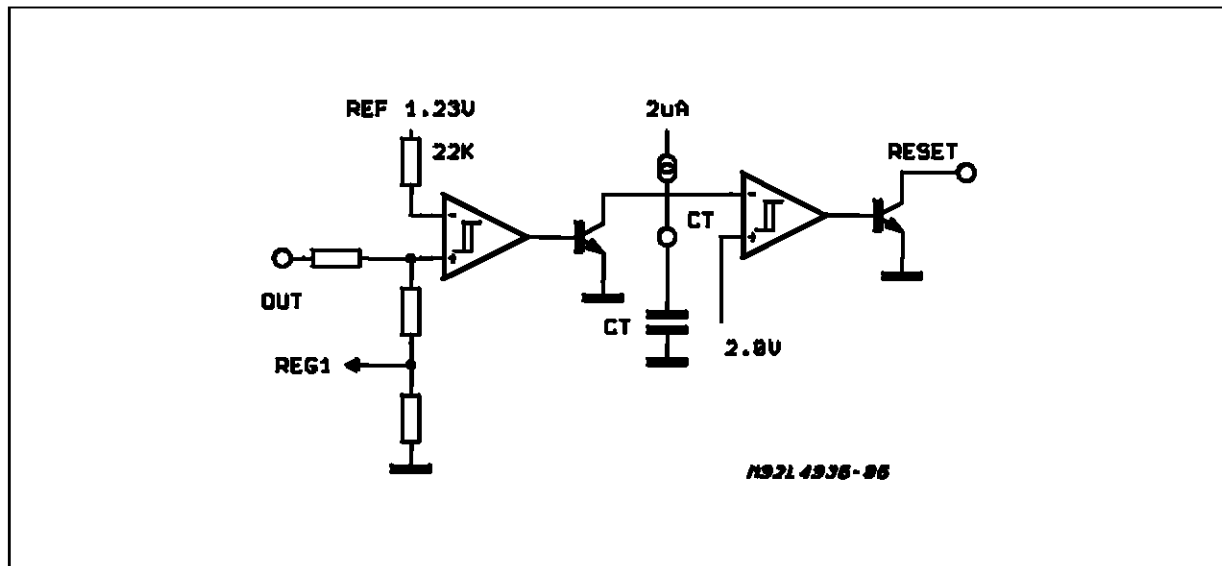
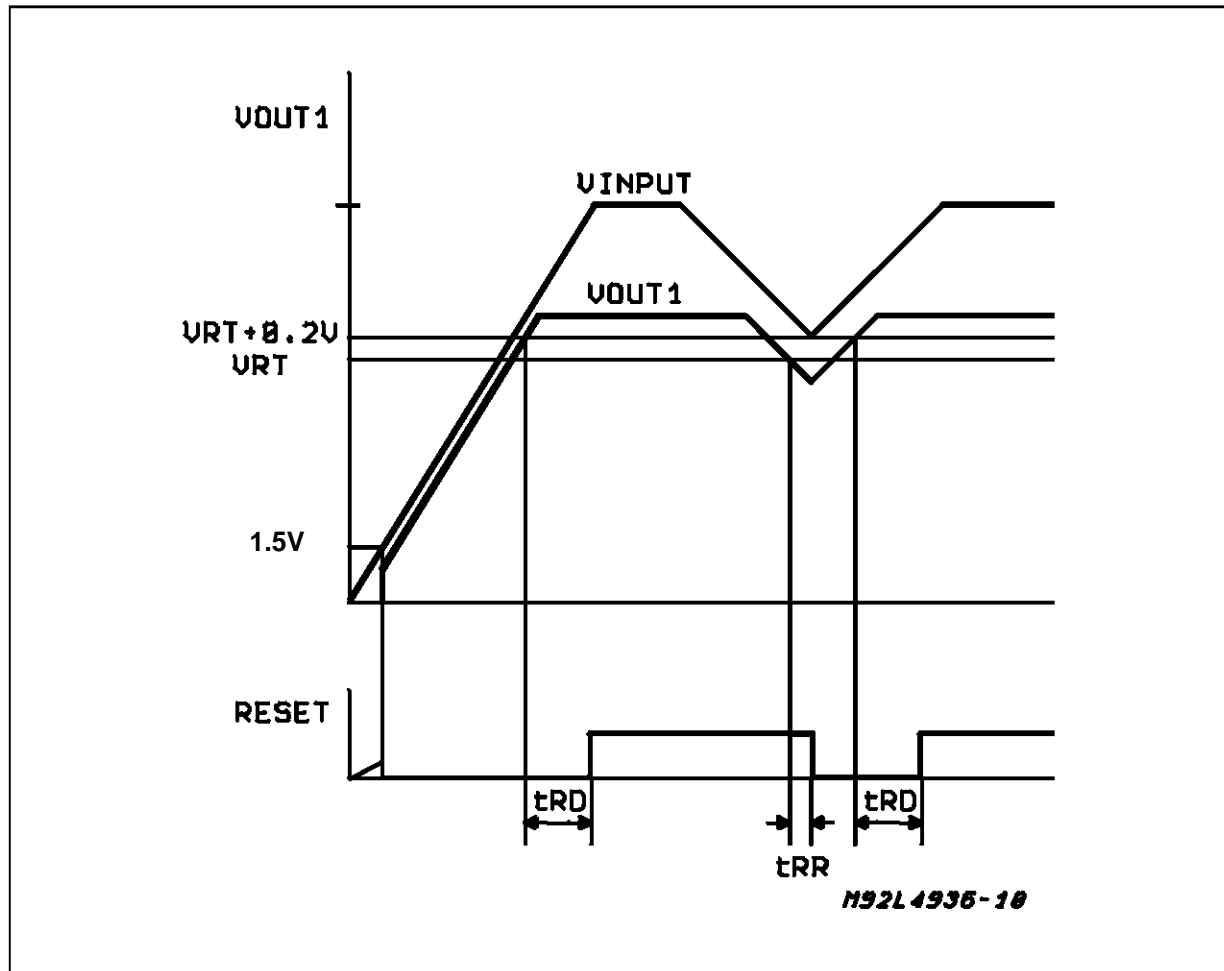
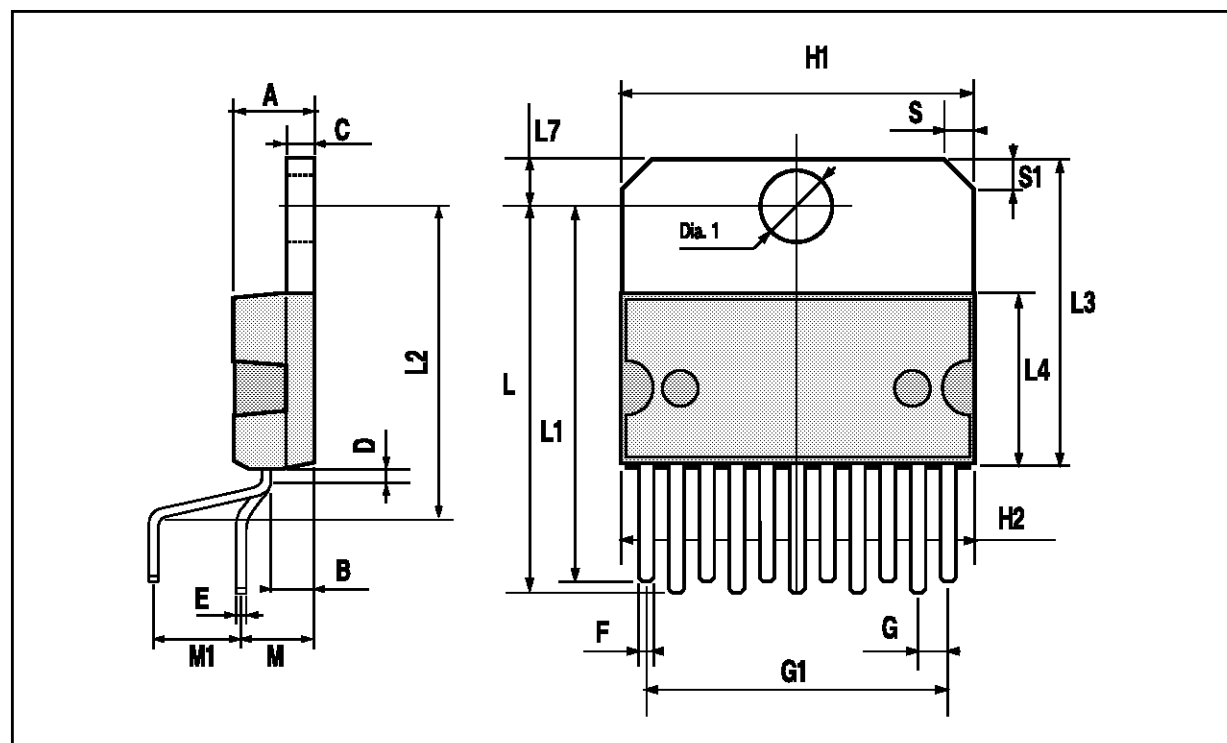

Figure 5 : Typical Reset Output Waveforms.



MULTIWATT11 PACKAGE MECHANICAL DATA

DIM.	mm			inch		
	MIN.	TYP.	MAX.	MIN.	TYP.	MAX.
A			5			0.197
B			2.65			0.104
C			1.6			0.063
D		1			0.039	
E	0.49		0.55	0.019		0.022
F	0.88		0.95	0.035		0.037
G	1.45	1.7	1.95	0.057	0.067	0.077
G1	16.75	17	17.25	0.659	0.669	0.679
H1	19.6			0.772		
H2			20.2			0.795
L	21.9	22.2	22.5	0.862	0.874	0.886
L1	21.7	22.1	22.5	0.854	0.87	0.886
L2	17.4		18.1	0.685		0.713
L3	17.25	17.5	17.75	0.679	0.689	0.699
L4	10.3	10.7	10.9	0.406	0.421	0.429
L7	2.65		2.9	0.104		0.114
M	4.25	4.55	4.85	0.167	0.179	0.191
M1	4.73	5.08	5.43	0.186	0.200	0.214
S	1.9		2.6	0.075		0.102
S1	1.9		2.6	0.075		0.102
Dia1	3.65		3.85	0.144		0.152



MULTIWATT15 PACKAGE MECHANICAL DATA

DIM.	mm			inch		
	MIN.	TYP.	MAX.	MIN.	TYP.	MAX.
A			5			0.197
B			2.65			0.104
C			1.6			0.063
D		1			0.039	
E	0.49		0.55	0.019		0.022
F	0.66		0.75	0.026		0.030
G	1.02	1.27	1.52	0.040	0.050	0.060
G1	17.53	17.78	18.03	0.690	0.700	0.710
H1	19.6			0.772		
H2			20.2			0.795
L	21.9	22.2	22.5	0.862	0.874	0.886
L1	21.7	22.1	22.5	0.854	0.870	0.886
L2	17.65		18.1	0.695		0.713
L3	17.25	17.5	17.75	0.679	0.689	0.699
L4	10.3	10.7	10.9	0.406	0.421	0.429
L7	2.65		2.9	0.104		0.114
M	4.25	4.55	4.85	0.167	0.179	0.191
M1	4.63	5.08	5.53	0.182	0.200	0.218
S	1.9		2.6	0.075		0.102
S1	1.9		2.6	0.075		0.102
Dia1	3.65		3.85	0.144		0.152

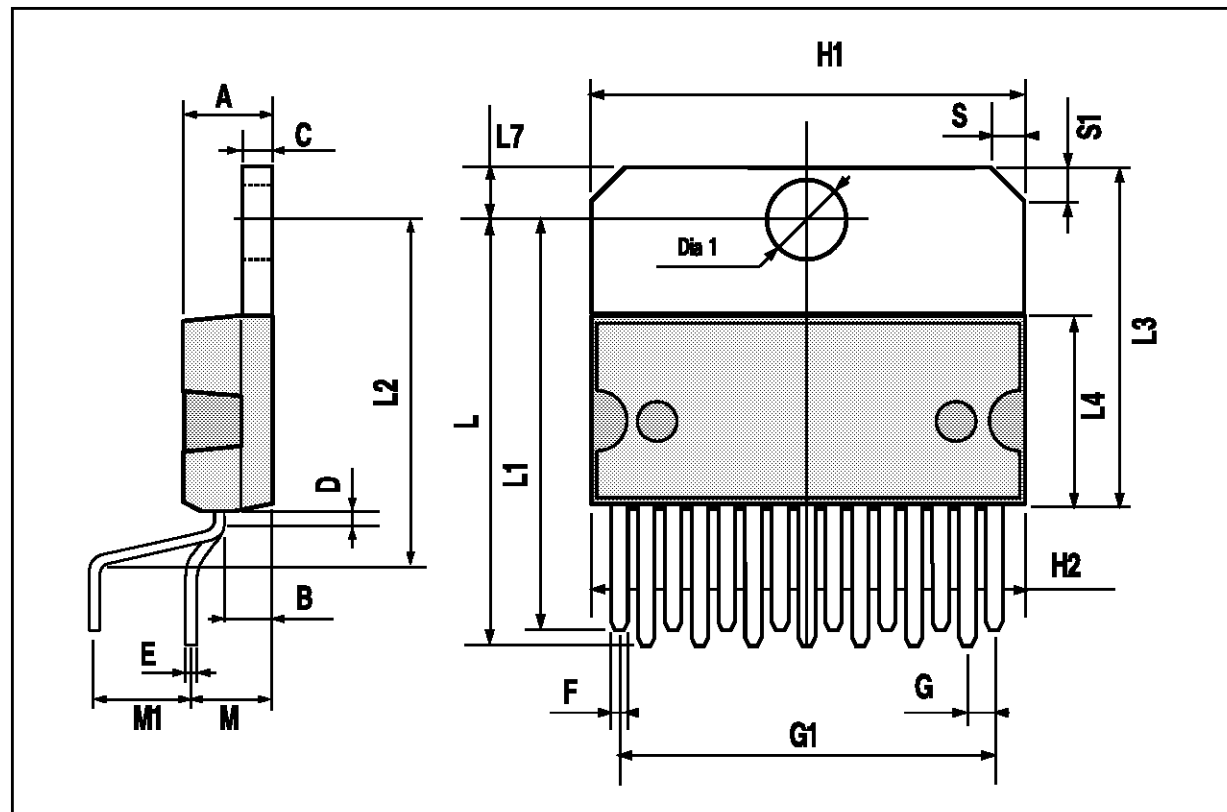

Information furnished is believed to be accurate and reliable. However, SGS-THOMSON Microelectronics assumes no responsibility for the consequences of use of such information nor for any infringement of patents or other rights of third parties which may result from its use. No license is granted by implication or otherwise under any patent or patent rights of SGS-THOMSON Microelectronics. Specifications mentioned in this publication are subject to change without notice. This publication supersedes and replaces all information previously supplied. SGS-THOMSON Microelectronics products are not authorized for use as critical components in life support devices or systems without express written approval of SGS-THOMSON Microelectronics.

© 1995 SGS-THOMSON Microelectronics - All Rights Reserved
MULTIWATT® is a Registered Trademark of SGS-THOMSON Microelectronics

SGS-THOMSON Microelectronics GROUP OF COMPANIES
Australia - Brazil - France - Germany - Hong Kong - Italy - Japan - Korea - Malaysia - Malta - Morocco - The Netherlands - Singapore -
Spain - Sweden - Switzerland - Taiwan - Thailand - United Kingdom - U.S.A.