

3.5A STEP DOWN SWITCHING REGULATOR

PRODUCT PREVIEW

- 3.5A STEP DOWN CONVERTER
- OPERATING INPUT VOLTAGE FROM 8V TO 55V
- 3.3V AND 5.1V (+/-2%) FIXED OUTPUT VOLTAGES
- OUTPUT VOLTAGE ADJUSTABLE FROM 3.3V TO 40V
- SWITCHING FREQUENCY IN EXCESS OF 200KHZ
- VOLTAGE FEED FORWARD
- ZERO LOAD CURRENT OPERATION
- INTERNAL CURRENT LIMITING
- PRECISE 5.1V (1.5%) REFERENCE VOLTAGE
- INPUT/OUTPUT SYNCHRONIZATION FUNCTION
- INHIBIT FOR ZERO CURRENT CONSUMPTION
- PROTECTION AGAINST FEEDBACK DISCONNECTION
- THERMAL SHUTDOWN

MULTIPOWER BCD TECHNOLOGY

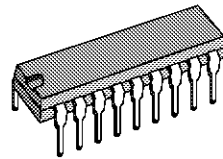

POWERDIP (12+3+3)

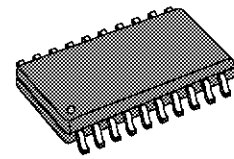

SO20

- SOFT START FUNCTION

DESCRIPTION

The L4973 is a step down monolithic power switching regulator delivering 3.5A at fixed voltages of 3.3V or 5.1V and using a simple external divider output adjustable voltage up to 40V.

BLOCK DIAGRAM

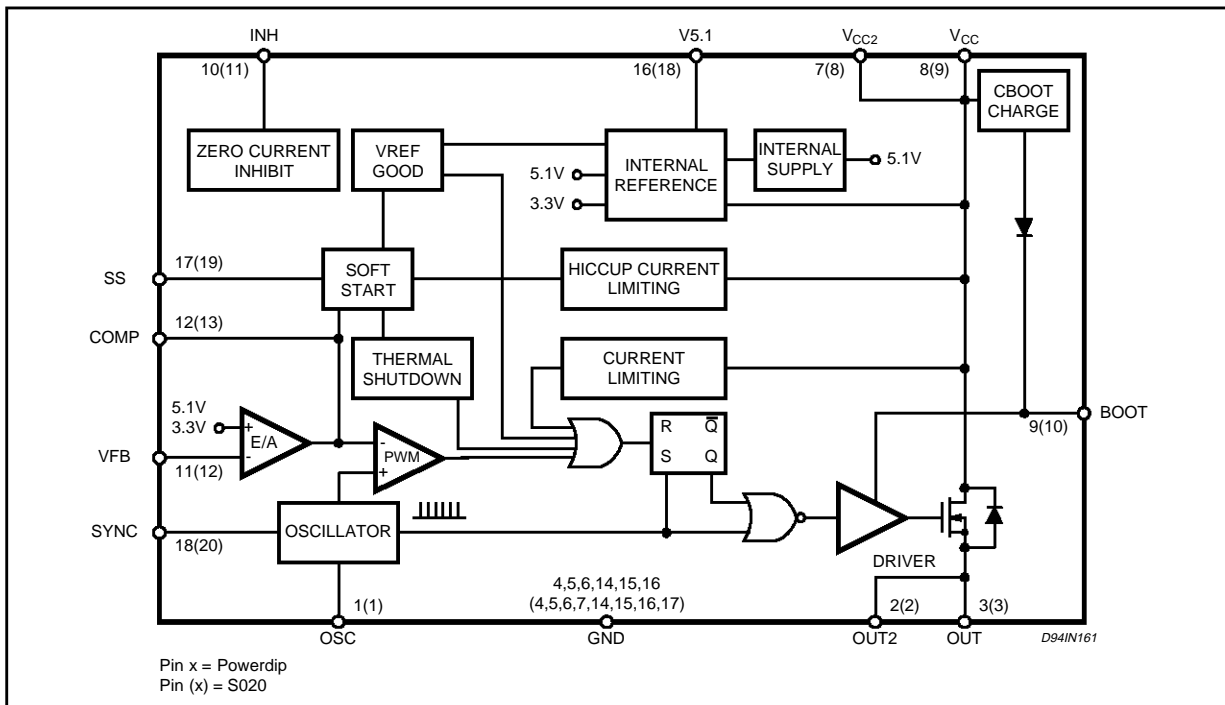

L4973V3 - L4973V5 - L4973D3 - L4973D5

Realized in BCD mixed technology, the device uses an internal power D-MOS transistor (with a typical $R_{ds(on)}$ of 0.15ohm) to obtain very high efficiency and very fast switching times.

Switching frequency in excess of 200KHz are achievable (the maximum power dissipation of the packages must be observed).

A wide input voltage range between 8V to 55V and output voltages regulated from 3.3V to 40V cover the majority of the today applications.

Features of this new generation of DC-DC converter includes pulse by pulse current limit, hiccup mode for short circuit protection, voltage feed forward regulation, soft start, input/output synchronization, protection against feedback loop disconnection, inhibit for zero current consumption and thermal shutdown.

The proposed packages are in plastic dual in line, DIP-18 (12+3+3) for standard assembly, and SO20 (12+4+4) for SMD assembly.

PIN CONNECTIONS (Top view)

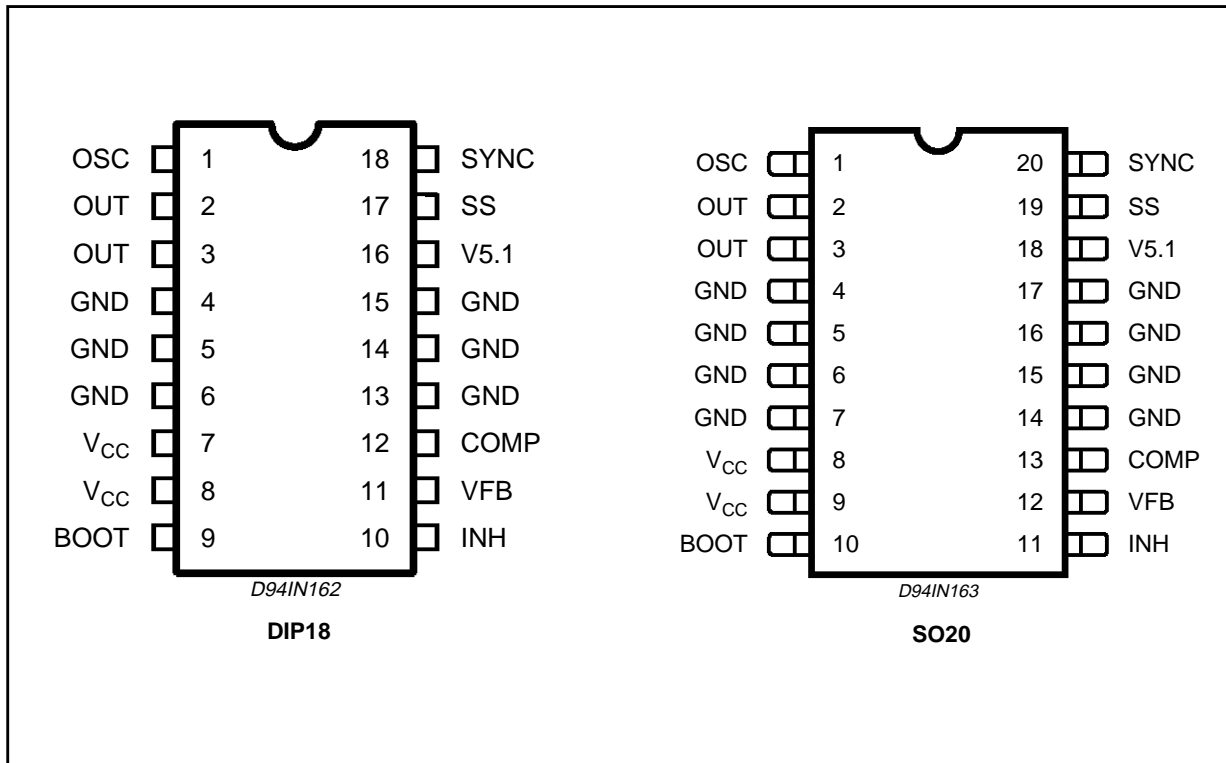

THERMAL DATA

Symbol	Parameter		DIP18	SO20	Unit
$R_{th(j-pin)}$	Thermal Resistance Junction to pin	Max.	12	15	°C/W
$R_{th(j-amb)}$	Thermal Resistance to Ambient	Max.	60 (*)	80 (*)	°C/W

(*) Package mounted on board.

ABSOLUTE MAXIMUM RATINGS

Symbol		Parameter	Value	Unit	
DIP-18	SO-20				
V ₇ ,V ₈	V ₉ ,V ₈	Input voltage	58	V	
V ₂ ,V ₃	V ₂ ,V ₃	Output DC voltage Output peak voltage at t=0.1us f=200KHz	-1 -5	V V	
I ₂ ,I ₃	I ₂ ,I ₃	Maximum output current	int. limit.		
V ₉ -V ₈	V ₁₀ -V ₈		14	V	
V ₉	V ₁₀	Bootstrap voltage	70	V	
V ₁₁ ,V ₁₇ V ₁	V ₁₂ ,V ₁₉ V ₁	Analogs input voltage	14 -0.3	V V	
V ₁₂ ,V ₁₈	V ₁₃ ,V ₂₀		6 -0.3	V V	
V ₁₀	V ₁₁		V _{cc} -0.6	V V	
P _{tot}		Power dissipation a T _{pins} ≤ 90°C (T _{amb} = 70°C no copper area) (T _{amb} = 70°C 4cm copper area on PCB)	DIP-18	5 1.3 2	W W W
		Power dissipation a T _{pins} = 90°C	SO-20L	4	W
T _J ,T _{STG}		Junction and storage temperature	-40 to 150	°C	

PIN FUNCTIONS

PIN DIP-18	PIN SO-20	NAME	DESCRIPTION
11	12	COMP	E/A output to be used for frequency compensation
10	11	INH	A logic signal (active low) disables the device (sleep mode operation)
9	10	BOOT	A capacitor connected between this pin and the output allows to drive the internal D-MOS.
18	20	SYNC	Input/Output synchronization.
7,8	8,9	V _{cc}	Not regulated DC input voltage
2,3	2,3	OUT	Stepdown regulator output.
12	13	VFB	Stepdown feedback input. Connecting directly this pin to the output 3.3V and 5.1V are obtained; a voltage divider is requested for higher output voltages.
16	18	V5.1	Reference voltage externally available.
4,5,6 13,14,15	4,5,6,7 14,15,16,17	GND	Signal ground
1	1	OSC	An external resistor connected between the unregulated input voltage and Pin 1 and a capacitor connected from Pin 1 to ground fixes the switching frequency.(Line feed forward is automatically obtained)
17	19	SS	Soft start time constant. A capacitor connected between this terminal and ground determinates the soft start time.

L4973V3 - L4973V5 - L4973D3 - L4973D5

ELECTRICAL CHARACTERISTICS (Refer to the test circuit, $T_J = 25^\circ\text{C}$, $C_{\text{osc}} = 1.2\text{nF}$, $R_{\text{osc}} = 46.4\text{Kohm}$, $V_{\text{CC}} = 24\text{V}$ unless otherwise specified)

Symbol	Parameter	Test Conditions	Min.	Typ.	Max.	Unit
DYNAMIC CHARACTERISTICS						
	Input Voltage range (*)	$V_o = 3.3\text{V to } 40\text{V}$ $I_o = 3.5\text{A}$	8		55	V
	Output Voltage	$I_o = 0.5\text{A to } 3.5\text{A}$ $V_{\text{CC}} = 8\text{V to } 55\text{V}$ $V_o = 5.1\text{V}$	5	5.1	5.2	V
		$I_o = 0.5\text{A to } 3.5\text{A}$ $V_{\text{CC}} = 8\text{V to } 55\text{V}$, $V_o = 3.3\text{V}$	3.234	3.3	3.366	V
	Dropout voltage	$V_{\text{CC}} = 8\text{V}$, $I_o = 3.5\text{A}$		0.56	0.77	V
	Maximum limiting current	$V_{\text{CC}} = 8\text{V to } 35\text{V}$ $V_{\text{CC}} = 24\text{V to } 55\text{V}$	4	4.5	5	A
η	efficiency	$V_o = 5.1\text{V}$ $I_o = 3.5\text{A}$		90		%
		$V_o = 3.3\text{V}$ $I_o = 3.5\text{A}$		85		%
	Switching frequency		90	100	110	KHz
	Maximum switching frequency (**)	$R_{\text{osc}} = 27\text{Kohm}$, $V_o = V_{\text{ref}}$, $I_o = 1\text{A}$ $C_{\text{osc}} = 1.2\text{nF}$	200			KHz
	Supply Voltage Ripple Rejection	$V_i = V_{\text{CC}} + 2\text{ VRMS}$ $V_o = V_{\text{ref}}$, $I_o = 1\text{A}$, $f_{\text{ripple}} = 100\text{Hz}$	60			dB
$\Delta f_{\text{sw}}/\Delta V_i$	Voltage stability of switching frequency	$V_{\text{CC}} = 8\text{V to } 55\text{V}$		2	5	%
$\Delta f_{\text{sw}}/\Delta T_j$	Temperat. stability of switching frequency	$T_j = 0^\circ \text{ to } 125^\circ\text{C}$		2		%
REFERENCE SECTION						
	Reference voltage		5.02	5.1	5.18	V
	Line regulation	$V_{\text{CC}} = 8\text{V to } 55\text{V}$ $I_{\text{ref}} = 0\text{ mA}$		5	10	mV
	Load regulation	$I_{\text{ref}} = 0\text{ to } 5\text{mA}$ $I_{\text{ref}} = 0\text{ to } 20\text{mA}$		2 6	10 25	mV mV
	Short circuit current		30	65	100	mA
	Reference voltage stability Vs temperature	$T_j = 0^\circ \text{ to } 125^\circ\text{C}$		0.4		mV/°C
SOFT START						
	Soft start charge current		30	40	50	μA
	Soft start discharge current		15	20	25	μA
INHIBIT (not compatible with the 3.3V)						
	High level voltage		3.5			V
	Low level voltage				0.9	V
	Isink High level	$3.5\text{V} < V_{\text{INH}} < 12\text{V}$		1		μA
		$V_{\text{INH}} < 0.9\text{V}$		1		μA
DC CHARACTERISTICS						
	Total operating quiescent current			4	8	mA
	Quiescent current	duty cycle = 0		2	3.5	mA
	Total stand by quiescent current	$V_{\text{CC}} = 24\text{V}$ $V_{\text{CC}} = 55\text{V}$ $V_{\text{INH}} < 0.9$		100 150	200 300	μA μA

(*) Pulse testing with a low duty cycle.

(**) The maximum power dissipation of the packages must be observed.

ELECTRICAL CHARACTERISTICS (continued)

Symbol	Parameter	Test Conditions	Min.	Typ.	Max.	Unit
ERROR AMPLIFIER						
	High level output voltage		11.5			V
	Low level output Voltage				0.65	V
	Source output current		200	300		μ A
	Sink output current		200	300		μ A
	Supply voltage ripple rejection	$V_{COMP} = V_{FB}$ $V_{CC} = 8V \text{ to } 55V$	60	80		dB
	DC open loop gain		60			dB
OSCILLATOR SECTION						
	Ramp valley		0.78	0.85	0.92	V
	Ramp peak	$V_{CC} = 8V$	2.1	2.3	2.5	V
		$V_{CC} = 55V$	10	10.6	11.2	V
	Maximum duty cycle		95	97		%
SYNC FUNCTION						
	High input voltage	$V_{CC} = 8V \text{ to } 55V$	3.5			V
	Low input voltage	$V_{CC} = 8V \text{ to } 55V$			0.9	V
	Slave sink current			0.3	0.5	mA
	Master output amplitude	$I_{source} = 5mA$	4	4.5		V
	Output pulse width	no load, $V_{sync} = 3.5V$	0.15	0.25		μ s

POWERDIP 18 PACKAGE MECHANICAL DATA

DIM.	mm			inch		
	MIN.	TYP.	MAX.	MIN.	TYP.	MAX.
a1	0.51			0.020		
B	0.85		1.40	0.033		0.055
b		0.50			0.020	
b1	0.38		0.50	0.015		0.020
D			24.80			0.976
E		8.80			0.346	
e		2.54			0.100	
e3		20.32			0.800	
F			7.10			0.280
l			5.10			0.201
L		3.30			0.130	
Z			2.54			0.100

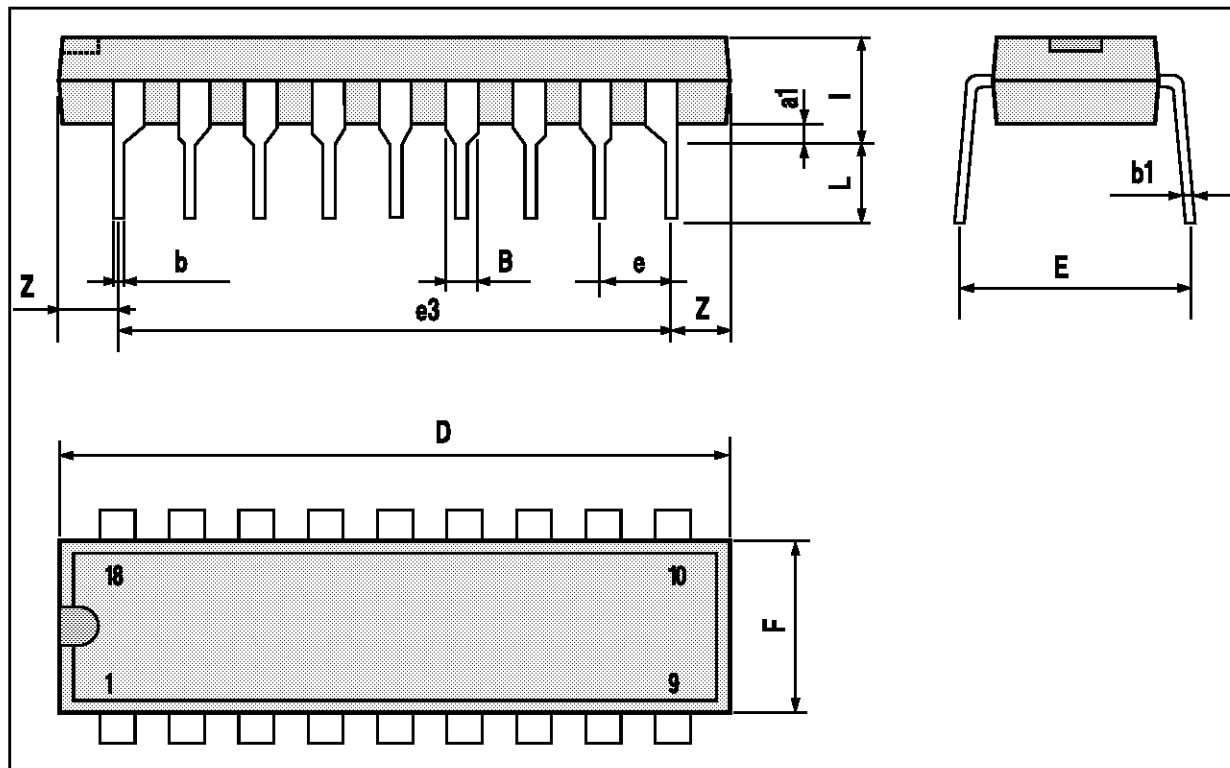

SO20 PACKAGE MECHANICAL DATA

DIM.	mm			inch		
	MIN.	TYP.	MAX.	MIN.	TYP.	MAX.
A			2.65			0.104
a1	0.1		0.3	0.004		0.012
a2			2.45			0.096
b	0.35		0.49	0.014		0.019
b1	0.23		0.32	0.009		0.013
C		0.5			0.020	
c1	45 (typ.)					
D	12.6		13.0	0.496		0.512
E	10		10.65	0.394		0.419
e		1.27			0.050	
e3		11.43			0.450	
F	7.4		7.6	0.291		0.299
L	0.5		1.27	0.020		0.050
M			0.75			0.030
S	8 (max.)					

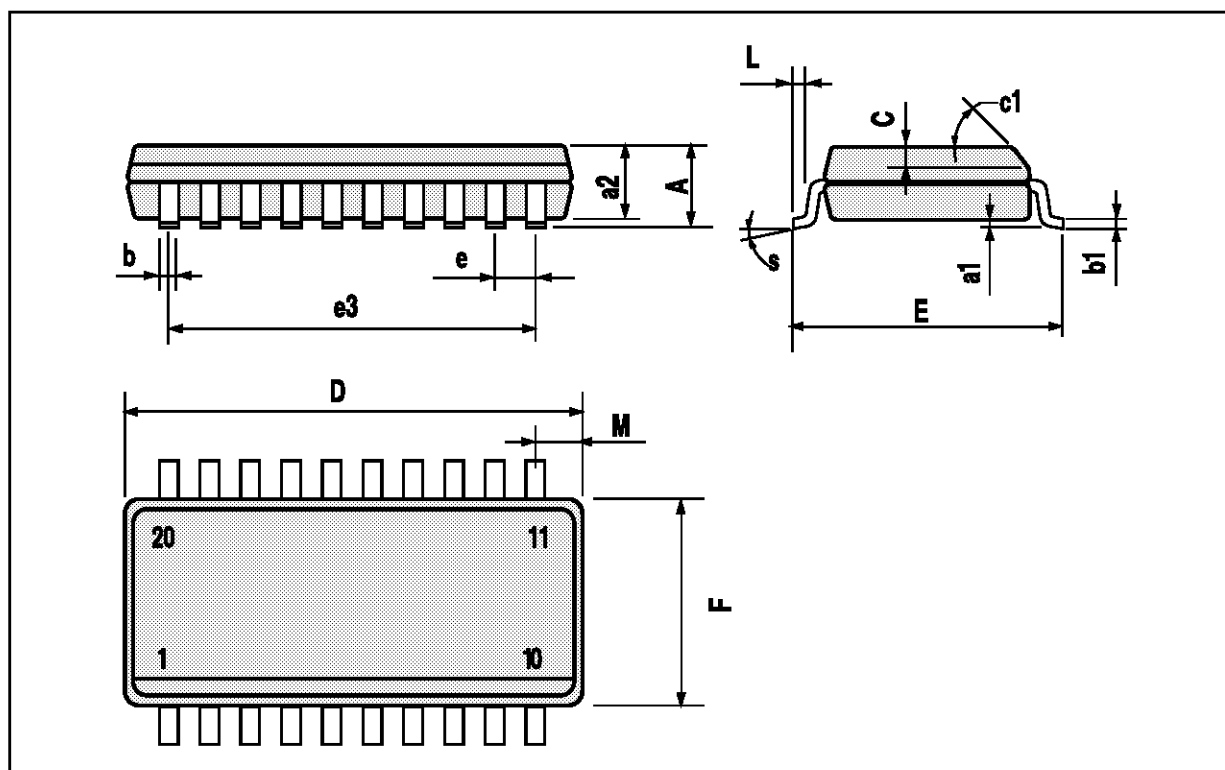

Information furnished is believed to be accurate and reliable. However, SGS-THOMSON Microelectronics assumes no responsibility for the consequences of use of such information nor for any infringement of patents or other rights of third parties which may result from its use. No license is granted by implication or otherwise under any patent or patent rights of SGS-THOMSON Microelectronics. Specifications mentioned in this publication are subject to change without notice. This publication supersedes and replaces all information previously supplied. SGS-THOMSON Microelectronics products are not authorized for use as critical components in life support devices or systems without express written approval of SGS-THOMSON Microelectronics.

© 1994 SGS-THOMSON Microelectronics - All Rights Reserved

SGS-THOMSON Microelectronics GROUP OF COMPANIES

Australia - Brazil - France - Germany - Hong Kong - Italy - Japan - Korea - Malaysia - Malta - Morocco - The Netherlands - Singapore - Spain - Sweden - Switzerland - Taiwan - Thailand - United Kingdom - U.S.A.