

SINGLE CHIP READ & WRITE CHANNEL

ADVANCE DATA

- SUPPORTS 9-32Mbit/s DATA RATE OPERATION IN RLL [1,7] CONSTRAINT
 - Data Rate is Programmable
- SUPPORTS ZONED BIT RECORDING APPLICATIONS
- LOW POWER OPERATION (500mW TYPICAL @ 5V @ 32Mbits/Sec)
- PROVIDES PROGRAMMABILITY THROUGH SERIAL MICROPROCESSOR INTERFACE AND INTERNAL REGISTERS
 - Bi-directional access to internal registers of pulse detector, filter, servo demodulator, frequency synthesizer and data separator.
- PROGRAMMABLE POWER DOWN MODES
 - Full power-down mode (5mW max.)
- POWER SUPPLY RANGE 4.3 to 5.5V

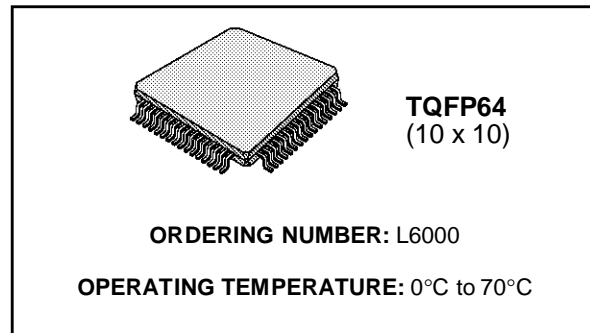

pulse detector, programmable active filter, servo demodulator, frequency synthesizer, and data separator, at data rates up to 32 Mbit/s. A single external resistor sets the reference current for the internal DAC which, in turn, fixes the data rate.

This device is programmed through a serial port and banks of internal registers. It is fully compatible with zoned bit recording applications. External components do not need to be changed when switching between zones. The L6000 is manufactured using an advanced BiCMOS technology.

DESCRIPTION

The L6000 is a 5V single chip read channel IC. It contains all the functions needed to implement a high performance read channel including the

PIN CONNECTION (Top view)

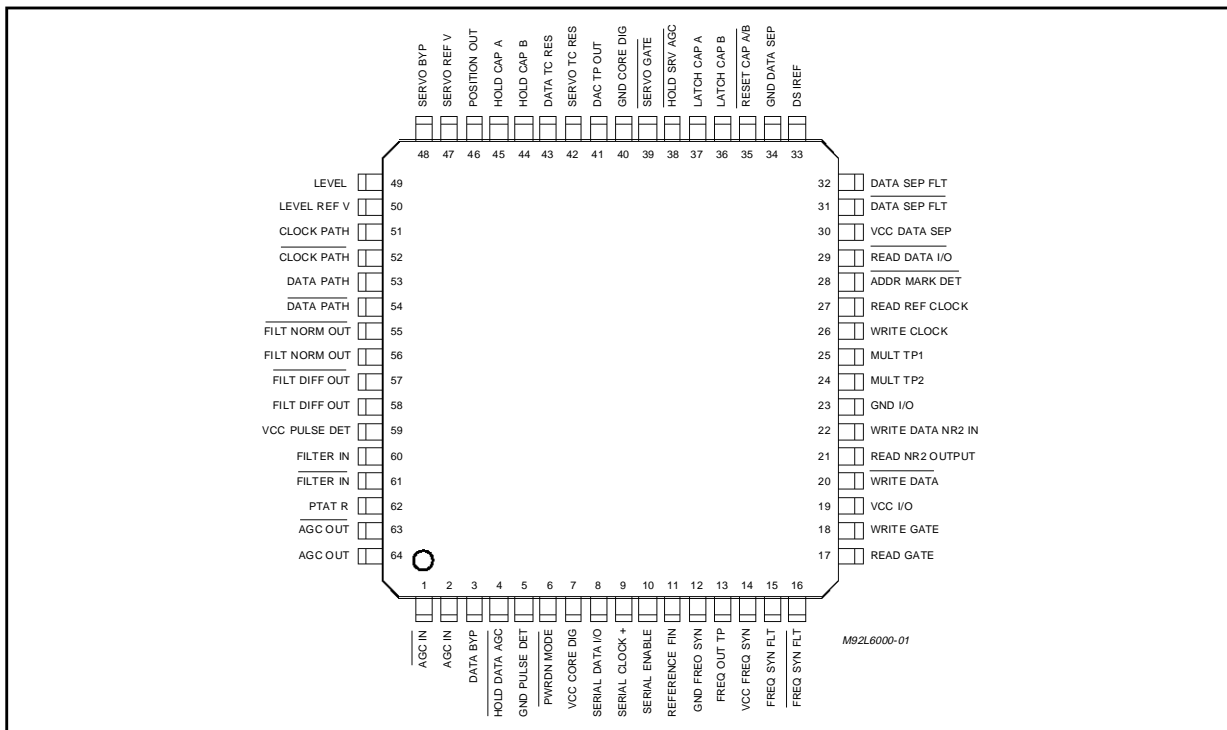

Figure 1a: Block Diagram (1 of 2)

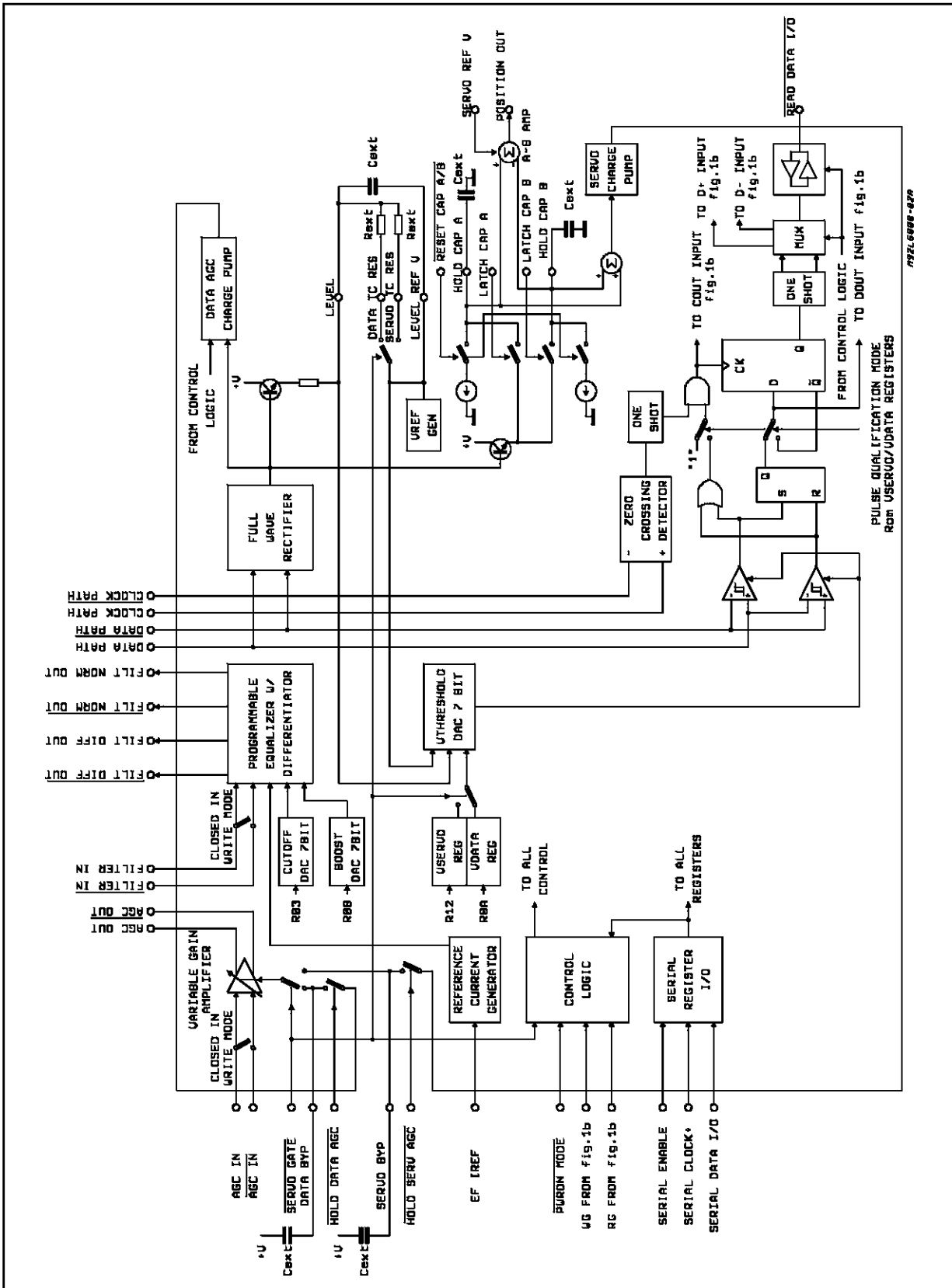
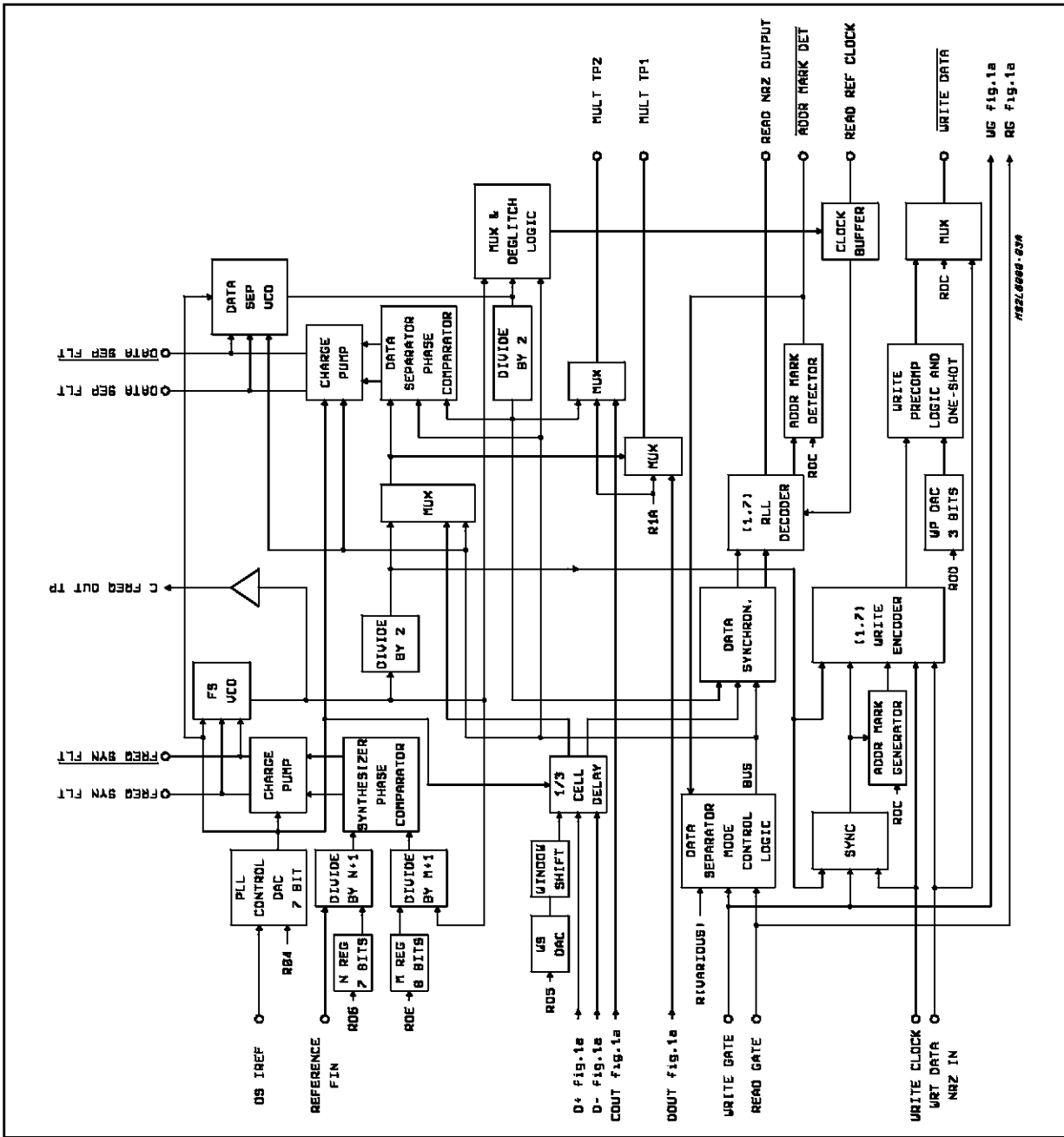

Figure 1b: Block Diagram (2 of 2)



ABSOLUTE MAXIMUM RATINGS

Symbol	Parameter	Value	Unit
Vcc	Positive Supply Voltage	- 0.5 to 7	V
	Voltage Applied to Logic Inputs	- 0.5 to Vccs + 0.5	V
	Voltage Applied to All Other Pins	- 0.5 to Vccs +0.5	V
Tstg	Storage Temperature	- 65 to +150	°C
Tj	Junction Temperature	130	°C

PIN DESCRIPTION

Pin #	Symbol	Type	Description
POWER SUPPLY			
30	Vcc DATA SEP	-	DATA SEPARATOR: PLL analog 5V supply.
14	Vcc FREQ. SYNTH	-	FREQUENCY SYNTHESIZER: PLL analog 5V supply.
7	Vcc CORE DIG	-	Internal ECL, CMOS logic digital supply.
19	Vcc I/O		TTL BUFFER I/O 5V SUPPLY.
59	Vcc PULSE DET	-	Pulse Detector/Servo Demodulator/Filter analog 5V supply.
34	GND DATA SEP	-	DATA SEPARATOR: PLL analog 5V ground.
12	GND FREQ SYN	-	FREQUENCY SYNTHESIZER: PLL analog 5Vground.
40	GND CORE DIG	-	Internal ECL, CMOS logic digital ground.
23	GND I/O	-	TTL Buffer I/O digital ground.
5	GND PULSE DET	-	Pulse Detector/Servo Demodulator/Filter analog circuit ground.
INPUT			
2, 1	<u>AGC IN</u> , AGC IN		AGC AMPLIFIER INPUTS: Differential AGC amplifier input pins.
53, 54	<u>DATA PATH</u> , DATA PATH	I	ANALOG INPUTS FOR DATA PATH: Differential analog inputs to data comparators, full-wave rectifier, and servo demodulator.
51, 52	<u>CLOCK PATH</u> , CLOCK PATH	I	ANALOG INPUTS FOR CLOCK PATH: Differential analog inputs to the clock comparator.
6	<u>PWRDN MODE</u>	I	PWRDN MODE CONTROL: TTL compatible power control pin. Assertion shuts down all circuitry, except the serial port. Deassertion and the appropriate bit set in PD register shuts down the selected circuitry. Active low.
4	<u>HOLD DATA AGC</u>	I	HOLD DATA AGC CONTROL INPUT: TTL compatible power control pin. Assertion disables the AGC charge pump and holds the input AGC amplifier gain. Active low.
38	<u>HOLD SRV AGC</u>	I	HOLD DATA AGC CONTROL INPUT: TTL compatible control pin. Assertion disables the SERVO charge pump. Active low.
47	SERVO REF V	I	SERVO REFERENCE .VOLTAGE INPUT: This voltage is set to half of the Vcc PULSE DET voltage
37	LATCH CAP A	I	LATCH CONTROL INPUT: TTL compatible input. Switches channel A into peak acquisition mode when low. Cap voltage doesn't change when high.
36	LATCH CAP B	I	LATCH CONTROL INPUT: TTL compatible input. Switches channel B into peak acquisition mode when low. Cap voltage doesn't change when high.
35	<u>RESET CAP A/B</u>	I	RESET CONTROL INPUT: TTL compatible input. Enables the discharge of channel A & B hold capacitors when asserted. Active low.
60, 61	<u>FILTER IN</u> , FILTER IN	I	FILTER SIGNAL INPUTS: Self biased differential input signals to active filter.
11	REFERENCE FIN	I	REFERENCE FREQUENCY INPUT: TTL input. Pin REFERENCE FIN has an internal pull up resistor. In the test mode, when frequency synthesizer is bypassed, the REFERENCE FIN frequency required is 3 times the data rate. REFERENCE FIN may be driven by a direct coupled TTL signal.
22	WRT DATA NRZ IN	I	WRITE DATA NRZ INPUT. TTL input. Connected to the READ NRZ OUTPUT pin to form a bidirectional data port. Pin WRT DATA NRZ IN has an internal pull up resistor.
17	READ GATE	I	READ GATE : See clocks and Modes.
26	WRITE CLOCK	I	WRITE CLOCK: TTL input Write mode clock. Must be synchronous with the Write Data NRZ input. For short cable delays, WRITE CLOCK may be connected directly to pin READ REF CLOCK. For long cable delays, WRITE CLOCK should be connected to a READ REF CLOCK return line matched to the NRZ data bus line delay.
18	WRITE GATE	I	WRITE GATE: TTL input. Enables the write mode. See Clocks and Modes.
39	<u>SERVO GATE</u>	I	SERVO GATE: TTL input. Enables the servo read mode. Active low.

PIN DESCRIPTION (continued)

Pin #	Symbol	Type	Description
OUTPUT			
64, 63	AGC OUT, AGC OUT	O	AGC AMPLIFIER OUTPUT: Differential AGC amplifier output pins.
29	READ DATA I/O	I/O	READ DATA I/O: Bi-directional TTL pin. Output is active in the servo mode or when both READ GATE and WRITE GATE are deasserted. In test mode, this is a TTL input used to drive the data separator. The TTL input is enabled by setting RDI in the control register CB.
46	POSITION OUT	O	POSITION ERROR SIGNAL: A Position error signal of A minus B output which is referenced to SERVO REF V.
56, 55	FILT NORM OUT, FILT NORM OUT	O	FILTER DIFFERENTIAL NORMAL OUTPUTS: Low pass & boosted filter output signals. Must be AC coupled to the next stage nominally DATA PATH.
58, 57	FILT DIFF OUT, FILT DIFF OUT	O	FILTER DIFFERENTIAL DIFFERENTIATED OUTPUTS: Differentiated filter outputs should be AC coupled to the next stage nominally CLOCK PATH.
28	ADDR MARK DET	O	ADDRESS MARK DETECT: Tristate output pin with TTL output levels. It is in its high impedance state when WRITE GATE is asserted. When READ GATE is asserted and the register bit is set for soft sector, an address mark search is initiated in the soft sector operation. This output is latched low (true) when an address mark has been detected. Deasserting pin READ GATE deasserts pin ADDR MARK DET.
25	MULT TP1	O	MULTIPLEXED TEST POINT OUTPUT: An open emitter ECL output test point. The test point output is enabled by Setting ED in the control register CB. The controlling signal is PD_TEST in the control register CA. When PD_TEST is low, the test point output is the delayed read data DRD. The positive edges of this signal indicate the data bit position. The positive edges of the DRD and VCOREF outputs can be used to estimate window centering. The time jitter of DRD's positive edge is an indication of media bit jitter. When PD_TEST is high the test point out is the comparator of the pulse qualifier. The positive edge indicates that the input signal has exceeded the positive threshold while a negative edge indicates that the input signal has gone below the negative threshold. Two external resistors are required to use this pin. They should be removed during normal operation to reduce power dissipation.
21	READ NRZ OUTPUT	O	NRZ OUTPUT DATA: Tristate output pin with TTL output levels. It is in its high impedance state when READ GATE is deasserted. Read data output when READ GATE is asserted.
27	READ REF CLOCK	O	READ REFERENCE CLOCK: TTL output. A multiplexed clock source used by the controller, see Clocks and Modes. During a mode change, no glitches are generated and no more than one lost clock pulse will occur. READ REF CLOCK remains Fout/3 after READ GATE is asserted, until after synchronized bits are detected.
24	MULT TP2	O	MULTIPLEXED TEST POINT OUTPUT: An open emitter ECL output test point. This test point output is enabled by using the same control bit enabling the MULT TP1 output. When the controlling signal, PD_TEST is deasserted, the test point output is the VCO reference input (VCOREF) to the phase detector. The positive edges are phase locked to Delayed Read Data (DRD). The negative edges of this open emitter output signal indicate the edges of the decode window. When PD_TEST is high, the test point output represents the state of the clock comparator in the pulse qualifier. The signal transitions indicate zero crossing of the differentiated signal from the electronic filter. Two external resistor are required to use this pin. They should be removed during normal operation to reduce power dissipation.
20	WRITE DATA	O	WRITE DATA: TTL output. Encoded write data output. The data is automatically resynchronized (independent of the delay between READ REF CLOCK and WRITE CLOCK) to the reference clock FSout. Falling edge of the WRITE DATA is the data edge.
13	FREQ OUT TP	O	REFERENCE FREQUENCY OUTPUT: An open emitter ECL output test point. The frequency is the frequency synthesizer output frequency. This output is enabled by control register CA. Two external resistors are required to use this pin. They should be removed during normal operation to reduce power dissipation.

PIN DESCRIPTION (continued)

Pin #	Symbol	Type	Description
ANALOG			
50	LEVEL REF V	O	REFERENCE VOLTAGE: Reference voltage output for LEVEL. LEVEL REF V is derived by referencing VRG (an internal signal) to Vcc PULSE DET.
62	EF IREF	I	REFERENCE RESISTOR INPUT: An external 1% resistor (RX) is connected from this pin to ground to establish a precise reference current for the filter.
3	DATA BYP	–	AGC INTEGRATING CAPACITOR: Connected between DATA BYP and Vcc PULSE DET. This pin is used when data read mode.
48	SERVO BYP	–	AGC INTEGRATING CAPACITOR FOR SERVO: Connected between SERVO BYP and Vcc PULSE DET. This pin is used when in servo read mode
45	HOLD CAP A	–	PEAK HOLDING CAPACITOR A: Tied from this pin to GND PULSE DET.
44	HOLD CAP B	–	PEAK HOLDING CAPACITOR B: Tied from this pin to GND PULSE DET.
49	LEVEL	O	HYSTERESIS LEVEL: An NPN emitter output that provides a full-wave rectified signal from LEVEL to LEVEL REF V to set the hysteresis threshold time constant in conjunction with SERVO TC RES and DATA TC RES. This level used in VTHRESHOLD DAC.
33	DS IREF	I	REFERENCE RESISTOR INPUT: An external 1% resistor (RR) is connected to this pin to establish a precise internal reference current for the data separator and Frequency Synthesizer.
42	SERVO TC RES	I	SERVO TIME CONSTANT RESISTOR INPUT: An external resistor is connected from this pin to LEVEL to establish the hysteresis threshold time constant when not in Servo mode.
15, 16	FREQ SYN FLT, FREQ SYN FLT	–	PLL FILTER: The two connection points for the frequency synthesizer PLL differential filter components.
32, 31	DATA SEP FLT, DATA SEP FLT	–	PLL FILTER: THE Two connection points for the data separator PLL differential filter components.
41	DAC TP OUT	O	DAC OUTPUT: A test point for some of the on-chip DACs. The output of an internal DAC is selected by the values of TDAC1 (MSB) and TDACO (LSB) in the WS register. The selected DAC output and its corresponding select bits are as follows: FC_DAC (00), VTH_DAC (0 1), WS_DAC (1 0), and WP_DAC (1 1). When not using the DAC TP OUT pin, the preferred setting is to select the FC_DAC.
SERIAL PORT			
10	SERIAL ENABLE	I	SERIAL DATA ENABLE: Active high input pin to enable the serial port CMOS input levels.
8	SERIAL DATA I/O	I/O	SERIAL DATA: Input/Output pin for serial data; 8 instruction/address bits are sent first followed by 8 data bits. CMOS Input/Output levels.
9	SERIAL CLOCK+	I	SERIAL DATA CLOCK: Positive edge triggered clock input for the serial data CMOS input levels. The pin has an internal pull-up resistor.

SYSTEM DESCRIPTION

Pulse Detector Section

Fast attack/decay modes for rapid AGC recovery. Dual rate charge pump for fast transient recovery. Low Drift AGC hold circuitry supports programmable gain, non-AGC operation. Temperature compensated, exponential control AGC. Shorted input switch for transient recovery, during Power down & Write to read & Idle mode transitions. Wide Bandwidth, high precision full-wave rectifier. Dual mode pulse qualification circuitry allows either independent positive and negative threshold qualification to suppress error propagation or hysteresis comparison which implements alternating polarities. Differential qualifier comparator. TTL READ DATA I/O signal output available during servo and idle modes. Timing for shorted inputs and fast decay functions set internally. 0.5 ns max. pulse pairing with sine wave input.

Embedded Servo Demodulator Section

Dual servo burst (A/B) capture with Position Error Signal Output. Servo AGC mode which holds sum of A and B bursts constant. Provision for on-chip switching of the hysteresis threshold time constant.

Programmable Filter Section

Programmable filter cutoff frequency ($f_c = 6$ to 18 MHz). Programmable pulse slimming equalization (0 to 9 dB Boost at the filter cutoff frequency). Matched path timing normal and differential low-pass outputs. Differential filter input and outputs for noise rejection $\pm 10\%$ cutoff frequency accuracy. $\pm 2\%$ maximum group delay variation in the passband maintained over the cutoff frequency tuning range ($f_c = 6$ to 18 MHz). Total harmonic distortion less than 1.5%. No external filter components required. Shorted input switch for transient recovery, during Power down & Write to Read & Idle mode transitions.

Frequency Synthesizer and Data Separator Section

1% frequency resolution. Data synchronizer and 1.7 RLL ENDEC. Fast acquisition phase lock loop with zero phase restart both to data and synthesizer. Fully integrated data separator. No external delay lines or active devices required. No external active PLL components required. Active window centering symmetry control via serial port. Window shift control $\pm 30\%$. Includes delayed read data and VCO clock monitor tests points. Programmable write precompensation. Hard and soft sector operation.

THERMAL DATA

Symbol	Parameter	Value	Unit
$R_{th\ j-amb}$	Thermal Resistance Junction-Ambient	100	$^{\circ}C/W$
$R_{th\ j-case}$	Thermal Resistance Junction-Case	20	$^{\circ}C/W$

RECOMMENDED OPERATING CONDITIONS

V_{ccn}	Supply Voltage	4.3 to 5.5	V
T_{amb}	Operating Ambient temperature	0 to 70	$^{\circ}C$
T_j	Junction Temperature	25 to 125	$^{\circ}C$

L6000

ELECTRICAL CHARACTERISTICS: $V_{CCn} = 5V + 10\% - 14\%$, $T_{amb} = 0$ to $70\text{ }^{\circ}\text{C}$, $T_j = 25$ to $125\text{ }^{\circ}\text{C}$, unless otherwise specified.

Symbol	Parameter	Test Condition	Min.	Typ.	Max.	Unit
POWER SUPPLY CURRENT AND POWER DISSIPATION						
I _{cc}	Power Supply Current	Outputs and test point pins open;	–	100	120	mA
P _d	Power Dissipation	T _{amb} = 27°C, 32Mbits/sec	–	500	660	mW
DIGITAL INPUTS AND OUTPUTS						
V _{IL}	Low Level Input Voltage		– 0.3		0.8	V
V _{IH}	High Level Input Voltage		2.0		V _{CC} I/O+0.3	V
I _{IL}	Low Level Input Current	V _{IL} = 0.4V	–		– 0.4	mA
I _{IH}	Low Level Input Current	V _{IH} = 2.4V	–		100	μA
V _{OL}	Low Level Output Voltage	I _{OL} = 4.0mA	–		0.5	V
V _{OH}	High Level Output Voltage	I _{OH} = –400μA	2.4		–	V
CMOS INPUTS: SERIAL ENABLE, SERIAL DATA AND SERIAL CLOCK						
V _{IL}	Low level Input Voltage	5V and 25°C	–		0.5	V
V _{IH}	High Level Input Voltage		4.5		–	V
t _r	Rise Time	4.3V, 70°C and C = 5pF	–		5.0	ns
t _f	Fall Time		–		4.5	ns
CMOS OUTPUTS: SERIAL DATA I/O						
V _{OL}	Low Level Output Voltage	5V and 25°C; I _{OL} = 4.07mA	–		0.5	V
V _{OH}	High Level Output Voltage	5V and 25°C; I _{OH} = +4.83mA	4.5		–	V
t _r	Rise Time	4.3V, 70°C and C = 15pF	–		5.5	ns
t _f	Fall Time		–		5.0	ns
TEST POINT OUTPUT LEVELS						
V _{IL}	Test Point High Level Output (MTP1, MTP2, FOUT)	261Ω to V _{CC} DATA SEP 402Ω to GND DATA SEP, V _{CC} DATA SEP = 5V	V _{CC} DATA SEP- 1.02		–	V
V _{IH}	Test Point Low Level Output (MTP1, MTP2, FOUT)	261Ω to V _{CC} DATA SEP 402Ω to GND DATA SEP, V _{CC} DATA SEP = 5V	–		V _{CC} DATA SEP- 1.62	V

PULSE DETECTOR AND SERVO DEMODULATOR CHARACTERISTICS

Symbol	Parameter	Test Condition	Min.	Typ.	Max.	Unit
AGC Amplifier Section						
The input signals are AC coupled to AGC IN and $\overline{\text{AGC IN}}$. AGC OUT and $\overline{\text{AGC OUT}}$ are AC coupled to FILTER IN and $\overline{\text{FILTER IN}}$. FILT NORM OUT and $\overline{\text{FILT NORM OUT}}$ are AC coupled to DATA PATH and $\overline{\text{DATA PATH}}$. Integrating capacitor C _a = 1000pF is connected between DATA BYP and V _{CC} PULSE DET. Unless otherwise specified, the output is measured differentially at AGC OUT and $\overline{\text{AGC OUT}}$, F _{in} = 4MHz, and the filter boost at FB = 0dB.						
	Input range	Filter Boost at FC = 0dB (bench test condition = 2.2 to 18MHz)	22	–	240	mVpp
	Input range	Filter Boost at FB = 9dB F _{in} = FC = 18MHz (bench test condition = 6 to 18MHz)	14	–	100	mVpp
$\overline{\text{DATA PATH}}/\text{DATA PATH}$	Voltage	AGC IN-AGC IN = 0.1Vpp	0.945	1.05	1.155	Vpp
	Voltage Variation	22mV < $\overline{\text{AGC IN}} = \text{AGC IN}$ < 240mV	–8.0	–	+8.0	%
	Gain Range		1.9	–	22	V/V

PULSE DETECTOR AND SERVO DEMODULATOR CHARACTERISTICS

Symbol	Parameter	Test Condition	Min.	Typ.	Max.	Unit
	Gain Sensitivity with respect to DATA BYP or SERVO BYPS pin voltage changes		27	28		dB/V
$\overline{\text{AGC OUT}}/\text{AGC OUT}$	THD	$\overline{\text{AGCOUT}} - \text{AGCOUT} = 0.75\text{Vpp}$	40	–	–	dB
	Differential Input Impedance	WG = low	4.7	6	8.4	K Ω
	Single Ended Input Impedance	WG = low WG = High or when IN Low - Z mode	2.5	3.5 0.65	4.5 0.8	K Ω K Ω
VOO	Output Offset Voltage	Filter not connected	– 200	–	+200	mV
en	Input Noise Voltage	AGC OUT, Rs = 0 Ω , gain = 22	–	10	15	nV/ $\sqrt{\text{Hz}}$
BW	Bandwidth	gain = 22 (1)	50	–	–	MHz
$\overline{\text{AGC OUT}}/\text{AGC OUT}$	Single ended output resistance	I _O = 0		140	180	Ω
PSRR	Power Supply Rejection Ratio	gain = 22, Fin = 5MHz	45			dB
CMRR	Common Mode Rejection Ratio		40	–	–	dB
	Gain Decay Time	$\overline{\text{AGC IN}} - \text{AGC IN} = 240\text{mVpp}$ to 120mVpp, $\overline{\text{AGC OUT}} - \text{AGC OUT} = 0.9$ Final Value	–	–	53	μs
	Gain Attack Time	$\overline{\text{AGC IN}} - \text{AGC IN} = 120\text{mVpp}$ to 240mVpp, $\overline{\text{AGC OUT}} - \text{AGC OUT} = 1.1$ Final Value	–	–	2	μs
AGC Control Section						
The input signal are AC coupled to DATA PATH and $\overline{\text{DATA PATH}}$, C = 1000pF.						
$\overline{\text{DATA PATH}}/\text{DATA PATH}$	Signal Input range	(bench test only)	–	1	1.5	Vpp
I _d	Discharge Current		2.8	4	5.2	μA
I _{df}	Fast Discharge	During Fast Decay mode Current	20xI _d –30%	20xI _d	20xI _d +30%	μA
I _{ch}	Charge Pump Attack Current	$\overline{\text{DATA PATH}} - \text{DATA PATH} = 1.15\text{Vpp}$	0.126	0.18	0.234	μA
I _{chf}	Charge Pump Fast Attack Current	$\overline{\text{DATA PATH}} - \text{DATA PATH} = 1.45\text{V}$	7xI _{ch} –30%	7xI _{ch}	7xI _{ch} +30%	μA
	DATA BYP Pin Leakage Current	WG = high	–0.1		+0.1	μA
LEVEL REF V	Reference Voltage		V _{cc} PULSE DET- 2.47	–	V _{cc} PULSE DET- 2.0	V
	LEVEL REF V Output Drive		–0.75	–	0.75	mA
	Duration of shorted input and Fast Decay modes	(*)	–	1	–	μs
	Level Output Gain	$\overline{\text{DATA PATH}} - \text{DATA PATH} = 0.5$ to 1Vpp	0.60	0.67	0.75	V/Vpp
	Level Output Bandwidth	f _{IN} = 11MHz	–	–	2	dB (2)
	Level Offset Voltage	Output - LEVEL REF V (I _L = 40 μA)	–40	–	+40	mV (2)

(*) Guaranteed by design.

(1) For correlation automatic test is performed at –3.8dB.

(2) Test limits under evaluation.

PULSE DETECTOR AND SERVO DEMODULATOR CHARACTERISTICS (continued)

Symbol	Parameter	Test Condition	Min.	Typ.	Max.	Unit
Data Comparator Section (The input signals are AC coupled to DATA PATH and $\overline{\text{DATA PATH}}$)						
DATA PATH/ DATA PATH	Signal Range		–	1	1.5	Vpp
	Differential Input resistance		8	–	14	K Ω
	Differential Input capacitance		–	–	5	pF
	Comparator Offset Voltage	(*)	–	–	± 4	mV
	Threshold Voltage Hysteresis	(*)	–	20Kth	–	%
Kth	Threshold Voltage Gain	$0.3 \leq (\text{LEVEL-LEVEL REF V}) \leq 0.75$, $K_{th} = \text{VTHDAC} \cdot 0.651/127$, $38 < \text{VTHDAC} < 125$, $V_{thresh} = K_{th} \cdot (\text{LEVEL-LEVEL REF V})$, also, $\%hyst = \text{VTHDAC} \cdot 97.6\%/127$	Kth-9%	Kth	Kth+9%	V/V
	Minimum Threshold Voltage	$\text{LEVEL-LEVEL REF V} \leq 0.1\text{V}$, $V_{thmin} = \text{VTHDAC} \cdot 0.099/127$ (*)	–	Vthmin	–	V
Clocking Section (The input signals are AC coupled to CLOCK PATH and $\overline{\text{CLOCK PATH}}$)						
	CLOCK PATH-CLOCK PATH Signal Range		–	–	1.5	Vpp
	Comparator Offset Voltage	(*)	–	–	± 4	mV
	Differential Input Resistance		8	–	14	K Ω
	Differential Input Capacitance		–	–	5	pF
	Pulse Paring	$V_s = 1\text{Vpp}$, $F = 4\text{MHz}$	–	–	0.5	ns
	Prpagation Delay to READ DATA I/O	$V_s = 20\text{mVpp}$ sq. wave	4	12	20	ns
Servo Section						
	SERVO REF V Voltage Range	$2.15\text{V} \leq \text{SERVO REF V} \leq 2.75\text{V}$	2.15	2.50	2.75	V
	SERVO REF V Input Bias Current		–1	0.2	1	μA
	Voltage Gain, SERVO REF V to POSITION OUT	$ \text{HOLD CAP A-HOLD CAP B} \leq 0.4\text{V}$	0.98	1.0	1.02	v/v
	POSITION OUT Pin Offset Voltage	HOLD CAP A-HOLD CAP B = 0V, SERVO REF V = 2.50V	–	0	± 12	mV
	POSITION OUT Pin High Level Output Voltage	HOLD CAP A-HOLD CAP B = +1.8V SERVO REF V = 2.50V, I _{source} = 0.5mA	V _{cc} PULSE	–	V _{cc} PULSE	V
	POSITION OUT Pin Low Level Output Voltage	HOLD CAP A-HOLD CAP B = -1.8V SERVO REF V = 2.50V I _{sink} = 0.5mA	GND PULSE	–	GND PULSE	V
RO	POSITION OUT Pin Output Resistance	$\text{VNG} + 1.5\text{V} \leq \text{POSITION OUT} \leq \text{VPG} - 1.5\text{V}$	–	–	50	Ω
	POSITION OUT GAIN	(POSITION OUT-SERVO REF V)/Vpp		1.8		V/Vpp (2)
	HOLD CAP A/B Charge Current	Absolute Value	4	–	–	mA

(*) Guaranteed by design.

(2) Test limits under evaluation.

PULSE DETECTOR AND SERVO DEMODULATOR CHARACTERISTICS (continued)

Symbol	Parameter	Test Condition	Min.	Typ.	Max.	Unit
Id	HOLD CAP A/B Disch. Current	Absolute value	0.8	1.5	2.2	mA
ILKG	HOLD CAP A/B Leakage Cur.		–	–	±0.5	µA
ILKG	SERVO BYP Pin Leakage Cur.	HOLDS = Low	–	–	±0.2	µA
K4	SERVO BYP Pin Charge/Discharge Current		450	640	880	µA/Vpp
K5		$I_{byps} = K4 \cdot [K5 - DATAPATH_{App} - DATAPATH_{Bpp}]$	0.70	1.00	1.30	V/V
	Maximum SERVO BYP Pin Charge Current		190	300	490	µA
Tper	READ DATA I/O Output Pulse Period	CL ≤ 15pF	50	–	–	ns
T1	READ DATA I/O Output Pulse Low Time	RDIO ≤ 0.8V	9	23	33	ns
Th	READ DATA I/O Output Pulse High Time	RDIO ≥ 0.8V	29	–	–	ns
Tf	READ DATA I/O Output Pulse Fail Time	CL ≤ 15pF, 2.0V to 0.8V	–	–	5	ns
Tr	READ DATA I/O Output Pulse Rise Time	CL ≤ 15pF, 0.8V to 2.0V	–	–	8	ns

PROGRAMMABLE FILTER CHARACTERISTICS

Symbol	Parameter	Test Condition	Min.	Typ.	Max.	Unit
Test Condition: Vccn = 5V + 10% - 14%, T _{amb} = 0 to 70°C, T _j = 25 to 125°C, unless otherwise specified. The input signals are AC coupled to FILTER and FILTER IN. C ≥ 22nF.						
FC	Filter Cutoff Frequency, f at -3dB point	FC = 0.141732MHz * FCDAC, 42 ≤ FCDAC ≤ 127, FCDAC is value of frequency DAC	6	–	18	MHz
FCA	Filter fc Accuracy	FCDAC = 127	– 10	–	+10	%
AN	FILT NORM OUT Differential Gain	f = 0.67FC, FBDAC = 0	1.6	2	2.4	V/V
AD	FILT DIFF OUT Differential Gain		0.9AN	–	1.1AN	V/V
FB	Frequency Boost @ FC	FB (dB) = 20log [0.0273 (FBDAC)+1], 0 ≤ FBDAC ≤ 127 FBDAC = 127	–	13	–	dB
		@6dB; FBDAC = 36 @13dB; FBDAC = 127	– 0.75 –2.0	–	+ 0.75 +2.0	dB dB
TGDO	Group Delay Variation without Boost	FC = 6MHz to 18MHz, f = 0.2FC to FC FBDAC = 0	– 3	–	+ 3	% (2)
		FC = 6MHz to 18MHz, FBDAC = 0, f = FC to 1.75FC	– 4	–	+ 4	% (2)
TGDB	Group Delay Variation with Maximum Boost	FC = 6 to 18MHz, f = 0.2 FC to FC, FBDAC = 127	– 3	–	+3	% (2)
		FC = 6MHz to 18MHz, FBDAC = 127, f = FC to 1.75FC	– 4	–	+4	% (2)
VIF	Filter Differential Input Dynamic Range	THD = 1% max, f = 0.67FC, FBDAC = 0	0.5	–	–	Vpp
		THD = 2% max, f = 0.67FC, FBDAC = 0	0.75	–	–	Vpp
RIN	Filter Diff. Input resistance		5.0	–	–	KΩ
RIZ	Filter Diff. Input Resistance with Shorted Inputs	Low – Z mode	100	300	500	Ω
CIN	Filter Diff. Input Capacitance		–	–	7	pF

(2) Test limits under evaluation.

PROGRAMMABLE FILTER CHARACTERISTICS(continued)

Symbol	Parameter	Test Condition	Min.	Typ.	Max.	Unit
EOUT	Output Noise Voltage Differentiated Output	BW = 100MHz, Rs = 50Ω FC = 18MHz, DACS = 0	–	2	7	mVrms
	Output Noise Voltage Normal Output		–	1.2	5	mVrms
	Output Noise Voltage Differentiated Output	BW = 100MHz, Rs = 50Ω FC = 18MHz, DACS = 127	–	4.6	7	mVrms
	Output Noise Voltage Normal Output		–	2	5	mVrms
IO-	Filter Output Sink Current		0.5	–	–	mA
IO+	Filter Output Source Current		2.0	–	–	mA
RO	Filter Output resistance Single Ended		–	–	200	Ω

Note: FBDAC is value of boost DAC (i.e., no boost)

Filter Control Characteristics (RX = 12KΩ)						
VRX	Reference Current Set Output Voltage	T _{amb} = 27°C (**)	–	1.5	–	V

FREQUENCY SYNTHESIZER CHARACTERISTICS (RR = 39KΩ)

FIN	Input Frequency		8		20	MHz
FOUT	Output Frequency		–		96	MHz
JFO	FOUT jitter	TO = 1/F _O ; F _{out} = 30MHz	–		±400	ps(pk)
	M Divide Number		80		255	–
	N Divide Number		25		127	–
TVCO	VCO Center Frequency Period	TO = (9.65 + 0.843 × DR) ⁻¹ FLTR1-FLTR1 = 0 (***)	0.9TO		1.1TO	ns
	VCO Frequency Dynamic Range	-1.5 ≤ FLTR1-FLTR1 ≤ +1.5, F _{out} = 54.0MHz (***)	25		±45	%
KVCO	VCO Control Gain	ω = 2π/TVCO -1.5 ≤ FLTR1-FLTR1 ≤ +1.5	0.14ω _o		0.26ω _o	rad/(V-s)
KD	Phase Detector Gain	KD = 0.7 + 0.43 × DR (***)	0.83KD		1.17KD	μA/rad
	KVCO × KD Product Accuracy		-28		+28	%

Reference Clock Characteristics:

	Reference Clock Low Time		20		–	ns
	Reference Clock High Time		20		–	ns

DATA SEPARATOR DYNAMIC CHARACTERISTICS AND TIMING (Unless otherwise specified, recommended operating conditions apply.)

Real Mode						
TRRC	Read Clock Rise Time	0.8V to 2.0V, CL ≤ 15pF	–		8	ns
TFRC	Read Clock Fall time	2.0V to 0.8V, CL ≤ 15pF	–		5	ns
	RRC Duty Cycle	DR = 32Mbit/s	43		57	%
TNS, TNH	NRZ(out) Set Up and Hold Time	DR ≤ 20Mbit/s (**)	15.5		–	ns
		DR > 20Mbit/s (**)	13		–	ns
TPNRZ	NRZ (out) Propagation Delay	(**)	–		±15	ns

(**) Bench test only.

(***) Preliminary data.

DATA SEPARATOR DYNAMIC CHARACTERISTICS AND TIMING (Continued)

Symbol	Parameter	Test Condition	Min.	Typ.	Max.	Unit
TAS, TAH	AMD Set Up and Hold Time	(**)	13		–	ns
TPAMD	AMD Propagation Delay	(**)	–		±15	ns
TD	1/3 Cell Delay	TD = 1/FSOUT, RR = 39KΩ (***)	0.8TD		1.2TD	ns
Write Mode						
TWD	Write Data Pulse Width	1.5V CL ≤ 15pF	2TFout/3 – 5		2TFout/3 + 5	ns
TRWD	Write Data Rise Time	0.8V to 2.0V, CL ≤ 15pF	–		9	ns
TFWD	Write Data Fall Time	2.0V to 0.8V, CL ≤ 15pF	–		5	ns
TRWC	Write Data Clock Rise Time	0.8V to 2.0V, CL ≤ 15pF	–		10	ns
TFWC	Write Data Clock Fall Time	2.0V to 0.8V, CL ≤ 15pF	–		8	ns
TSNRZ	NRZ Set Up Time		5		–	ns
THNRZ	NRZ Hold Time		5		–	ns
TPC	Precompensation Time Shift Magnitude Accuracy	TPCO = 0.04TREF TPC(max) = 0.28TREF TPC = nTPCO n = 0 1 ≤ n ≤ 7	– 0.5 n(0.8TPCO) – 0.5		+ 0.5 n(1.2TPCO) + 0.5	ns
Data Synchronization						
TVCO	VCO Center Frequency Period	FLTR2-FLTR2 = 0 TO = (8.95 + 0.786 × DR) ⁻¹ , RR = 39kΩ (***)	0.9TO		1.1TO	ns
	VCO Frequency Dynamic range	–1.5 ≤ FLTR-FLTR2 ≤ +1.5 (***)	±25		±45	%
KVCO	VCO Control Gain	$\omega_0 = \frac{2\pi}{T_{VCO}}$ –1.5 ≤ FLTR-FLTR2 ≤ +1.5	0.14Wo		0.26Wo	rad/(Vxs)
KD	Phase Detector Gain	Read: KD = 0.7 + 0.43 × DR, PLL REF = RD 3T Pattern, Non- Read: KD = 0.7 + 0.43 × DR, PLLREF = Fout / 2 (***)	0.83KD		1.17KD	A/rad
	KVCO × KD Product Accuracy		– 28		+ 28	%
	VCO Phase Restart Error		–		4	ns
	Decode Window Cent. Accuracy		–		±1.5	ns
	Decode Window Width		2TORC/3 – 1.5		–	ns

SERIAL PORT TIMING

Symbol	Parameter	Test Condition	Min.	Typ.	Max.	Unit
Tc	SERIAL CLOCK+ Data Clock Period		100		–	ns
Tck1	SERIAL CLOCK+ Low Time		40		–	ns
Tckh	SERIAL CLOCK+ High Time		40		–	ns
Tsens	Enable to Clock Delay Time		35		–	ns
Tsenh	Clock to Disable Delay Time	Delay from SERIAL CLOCK+ falling edge	100		–	ns
Tds	Data Setup Time		15		–	ns
Tdh	Data Hold Time		15		–	ns
Tdskewl	Clock to Valid Data Delay Time	Delay from SERIAL CLOCK+ falling edge	–		27	ns
Tdskewe	End of Valid Data to Clock		–		0	ns
Tsendl	Time to Tri-stated SERIAL DATA I/O	Delay from falling edge of SERIAL ENABLE	–		50	ns
Tturnd	SERIAL DATA I/O Turnaround Time		70		–	ns
Tsl	SERIAL ENABLE Low Time		200		–	ns

(**) Bench test only. (***) Preliminary data.

MODE CONTROL

WRITE GATE	READ GATE	SERVO GATE	PWRDN MODE	PWRDN Mode Register bits					DESCRIPTION
				PD	SD	FLT	DS	FS	
X	X	X	0	X	X	X	X	X	FULL POWER DOWN MODE : Only the serial interface remains operational. Switching from this mode to either Servo, Read or Idle modes initiates certain Read Channel states. Switching direct to Write modes is an illegal sequence. See Circuit Operation.
0	1	1	1	0	0	0	0	0	READ MODE : The entire FRONT END is turned on, the READ DATA I/O pin is inactive, and the AGC amplifier is active, with unshorted inputs (low-impedance mode off) and in tracking mode. The HOLD DATA AGC input is enabled. The Data Separator section initiates its Address Mark search on the assertion of READ GATE. It then starts its phase lock up sequence after Address Mark detection occurs. After $3 \cdot 3T$ following the Address Mark Detection the DS PLL is switched from Fout/2 to DRD and the lock-in sequence is initiated. After $19 \cdot 3T$ RRC switche from Fout/3 to DATA SYNCHRONIZER $V_{co}/3$ and NRZOUT is enabled. After. Read mode is maintained until the deassertion of READ GATE.
1	0	1	1	0	0	0	0	0	WRITE MODE : The FRONT END is inactive. The assertion of WRITE GATE causes the pin WRT DATA NRZ IN to become an active input, and the pins READ NRZ OUTPUT and ADDR MARK DET are floated. The inputs of both the Active filter and AGC amplifier are shorted (i.e. the low-impedance state entered). The PLL is locked to the Frequency Synthesizer divided by 30. n WRITE GATE assertion, two address marks (each 7 0's, 1, 7 0's, 1, 11 0's, 1, 11 0's) are generated and than the preamble of three 3T groups. WRT DATA NRZ IN must be zero until these patterns have been output from WRITE DATA. Write Mode is ended when Write Gate is deasserted. This starts the AGC Amplifier fast attack/decay currents acquisition, as well as unshorting the filter and AGC Amplifier inputs.
0	0	1	1	0	0	0	0	0	IDLE MODE : All the front end circuitry is active and operating. The Data Separator VCO is phase locked to Fout. The READ REF CLOCK outputs is the Frequency Synthesizer divided by 3. The pin READ NRZ OUTPUT is floated, ADDR MARK DET is high, READ DATA I/O is an active output of the pulses detected and HOLD DATA AGC is enabled. The inputs to the AGC Amplifier and filter are unshorted.
0	X	0	1	0	0	0	0	0	SERVO MODE 1 : The Pulse Detector and Servo Demodulator circuitry is operating, and the HOLD DATA AGC input is disabled. The Data Separator is on and it is phase locked to the Frequency Synthesizer which is also on. The pin READ DATA I/O is an active output.
0	X	0	1	0	0	0	1	1	SERVO MODE 2 : This mode has both the Frequency Synthesizer and Data Separator major blocks powered down, otherwise it is the same as SERVO MODE 1 . This mode is intended to reduce power dissipation when the system is just track following. Since only the Pulse Detector and Active Filter are powered on, this is also known as FRONT END TEST MODE.

MODE CONTROL(continued)

WRITE GATE	READ GATE	SERVO GATE	PWRDN MODE	PWRDN Mode Register bits					DESCRIPTION
				PD	SD	FLT	DS	FS	
X	X	X	1	1	1	0	1	1	TEST FILTER MODE : All major blocks except the Active Filter with Boost and Differentiator are powered down via Register (R02).
0	1	1	1	1	1	1	0	0	TEST DATA SEPARATOR READ MODE : Only the Data Separator and Frequency Synthesizer are on, and the pin READ DATA I/O is a test input.
1	0	1	1	1	1	1	0	0	TEST DATA SEPARATOR WRITE MODE : Only the Data Separator Write circuitry and the Frequency Synthesizer are on, for testing this specific circuitry.
X	X	X	1	1	1	1	0	0	TEST FREQUENCY SYNTHESIZER MODE: The front end is powered down. The Frequency Synthesizer is powered on for testing.

CIRCUIT OPERATION

General

The L6000 is a state of the art integrated read channel. The major functional blocks are :

- 1) Pulse Detector and Servo Demodulator, with dual servo burst measurement channels and 2 different qualification schemes for data.
- 2) Tunable Active equiripple filter with tunable Pulse slimming Boost and Active Differentiator.
- 3) (1, 7) RLL Combined Data Separator and ENDEC with active window centering and margin shifting from external commands.
- 4) A (M+1) divide by (N+1) Frequency synthesizer, using an external reference, and with 7 bits of DAC control accuracy.
- 5) A high speed serial interface controlling most functions and adjustment.

The L6000 is designed to be used with data rates as high as 32 Mbits/sec. Selection of a different recording density is done by setting new divisors in the Frequency Synthesizer via serial registers.

Power Management

The serial interface should load all appropriate control registers as soon as Power on Reset clears in the system. This prevents spurious conditions in all the affected blocks. After the registers are written, then the appropriate Power down modes can be used. The power management of the L6000 is under the control of the PWRDN MODE pin and the Power Down Control Register

(R02). The following table defines the power down modes and register bits controlling them:

Bit	Symbol	Function
0	PD	Pulse Detector Power Down
1	SD	Servo Demodulator Power Down
2	FLTR	Filter Power down
3	DS	Data Separator Power Down
4	FS	Frequency Synthesizer Power Down
5-7		Bits 5-7 are Hard-Coded to 111.

When the PWRDN MODE pin is asserted it powers down ALL functions with the exception of the serial port, which remains active in ALL power down modes. When the PWRDN MODE pin is deasserted, each individual major function block can be powered on or OFF separately from the serial port PD register. This feature is useful for sophisticated power saving state machines in systems. Toggling the bit in the register is the only necessary condition to turn on or OFF a major block; PWRDN MODE does not have to be cycled for each separate register load.

Serial Interface

The serial interface consists of the 3 signals SERIAL ENABLE, SERIAL CLOCK and SERIAL DATA I/O. The first two signals are inputs which are always powered on and active. SERIAL DATA I/O is a bidirectional pin which becomes an output on a register read. A value can be put into the L6000 (register WRITE) or a value can be interrogated from the L6000 (register READ). The bottom half of the diagram is a register READ where a value is interrogated from the L6000. To do either operation, SERIAL DATA ENABLE is

L6000

The internal register map for the serial port is shown below:

Address Bits		Blk Diag. Address	Symbol	Function					
LSB	MSB								
0	1	2	3	4	5	6			
0	1	0	0	0	0	0	R02	PD	Power Down Mode Control
1	1	0	0	0	0	0	R03	FCutoff	DACF-Filter cutoff Frequency Control
1	1	0	1	0	0	0	R0B	FBoost	DACS-Filter Boost Control
0	1	0	1	0	0	0	R0A	DVTH	Pulse Detector Voltage Threshold Control (Data Read Mode)
0	1	0	0	1	0	0	R12	SVTH	Pulse Detector Voltage Threshold Control (Servo Read Mode)
0	1	0	1	1	0	0	R1A	CA	Control A (Pulse Detector, Filter, frequency synthesizer Control)
0	1	1	0	0	0	0	R06	PSNN	Counter Value (frequency synthesizer)
0	1	1	1	0	0	0	R0E	PSMM	Counter Value (frequency synthesizer)
0	0	1	0	0	0	0	R04	VCO CENT	VCO Center Frequency
1	0	1	0	0	0	0	R05	WIN SHIFT	Window Shift Magnitude, Direction
1	0	1	1	0	0	0	R0D	WRT PREC	Write Precomp magnitude
0	0	1	1	0	0	0	R0C	CB	Control B (Data Separator, Endec Control)

The bit map of each register (except CA, CB & PD) is as follows:

FCutoff register	X	FC6	FC5	FC4	FC3	FC2	FC1	FC0
FBoost register	X	FB6	FB5	FB4	FB3	FB2	FB1	FB0
DVTH register	DEDC	VD6	VD5	VD4	VD3	VD2	VD1	VD0
SVTH register	SEDC	VS6	VS5	VS4	VS3	VS2	VS1	VS0
PSN register	X	N6	N5	N4	N3	N2	N1	N0
PSM register	M7	M6	M5	M4	M3	M2	M1	M0
VCO CENT register	FSC	DR6	DR5	DR4	DR3	DR2	DR1	DR0
WIN SHIFT register	TDAC1	TDAC0	WSE	WSD	WS3	WS2	WS1	WS0
WRT PREC register	X	X	X	X	WP3	WP2	WP1	WP0

where:

- X = Unused bit or don't care bit
- DEDC = Enable dual comparator qualifier in Data read mode.
- SEDC = Enable dual comparator qualifier in Servo read mode.
- FSC = The frequency synthesizer back comparator state
- TDAC1 = DAC Testing control bit #1
- TDAC0 = DAC Testing control bit #0

Control register CA:			Control register CB:		
Bit	Symbol	Function	Bit	Symbol	Function
0	EPDT	Enable Phase Detector (frequency synthesizer)	0	DW	Direct Write (Bypass Endec)
1	UT	<u>Pump Up</u> (FLTR1 sources current, FLTR1 sinks current) Test mode	1	GS	Enable Phase Detector Gain Switching
2	DT	<u>Pump Down</u> (FLTR1 sinks current, FLTR1 sources current) Test Mode	2	READ DATA IO	Pin Input Control
3	ET	Enable frequency synthesizer Circuit Function	3	EPDD	Enable Phase Detector (Data Separator)
4	BYPT	Bypass frequency synthesizer Circuit Function	4	UD	<u>Pump Up</u> (FLTR2 sources current, FLTR2 sinks current) Test mode
5	PD	TEST Enable Pulse Detector Test Points, COUT and DOUT	5	DD	<u>Pump Down</u> (FLTR sinks current, FLTR2 sources current) Test mode
6	FDCT	Force AGC Charge Pump into Fast Decay Mode	6	ED	Enable Data Separator Test Point Outputs
7		Unused	7	SOFT	Select Soft or Hard Sector Operation

asserted, then the SERIAL CLOCK+ is driven with the positive edge latching the state of SERIAL DATA. The actual data is latched into each register in the L6000 when SERIAL ENABLE is disasserted, so this signal MUST be driven low

after EACH register write; failure to deassert SERIAL ENABLE before a 17th SERIAL CLOCK+ will erase (invalidate) the previous 16 clock cycles. This also precludes SERIAL CLOCK+ from being a free running clock in the system. The

WRITE operation format is the following. The first bit is LOW, meaning write, followed by the 7bit register address, LSB first. The last 8 bits then are the data to be written to the register, also LSB first. During this to entire operation, SERIAL DATA I/O is an active input. The READ operation format is the following. The first bit now is HIGH, meaning read, and that is followed by the 7bit register address, LSB first. Upon receipt of the last bit of address, the pin SERIAL DATA I/O turns and becomes an active output, and outputs the 8 bits stored in the addressed register, LSB first on the following 8 SERIAL CLOCK+s.

Pulse Detector and Servo Demodulator

The purpose of the Pulse Detector is to qualify and detect the position of flux transitions written on the disk. The first stage of the Pulse Detector is the AGC amplifier. It is a wideband, differential amplifier which characteristic (Gain vs. Voltage) is positive slope and linear in DB and thermal compensated. The amplifier inputs have a low-impedance state where the inputs are shorted by a FET switch during modes where transients are likely to occur. The amplifier gain is controlled by 2 capacitors connected to the DATA BYP and SERVO BYP pins. The capacitor which controls the gain is selected by the SERVO GATE signal, asserted meaning Servo. In modes where the AGC is powered on, the selected capacitor will be charged from a dual rate charge pump. When the individual signals HOLD DATA AGC and HOLD SERVO AGC are asserted, the respective capacitors are disconnected from the charge pumps, but they remain in control of the AGC gain. If a fixed gain is desired, a voltage divider can be connected to either DATA BYP or SERVO BYP pin. In order to minimize the time required to restore the correct AGC output amplitude, the input switching to unshorted inputs and the AGC attack/delay currents are under timed, state control. The time to restore the inputs and AGC to normal operation is set to 1 usec. However, the AGC attack is controlled by amplitude and may take longer to settle. The nominal AGC attack (discharge) current is set to 0.18 mA but is increased to 1.3 mA when the AGC amplitude exceeds 1.25 times its set point. The nominal AGC decay current is increased from 0.004 mA to 0.080 mA in the recovery fast/decay mode. The high decay current of 80uA is only on for the second microsecond after the mode switch initiates the AGC reacquisition. Note that the fast Decay current is available in the recovery mode, while any amplitude transient over the threshold will activate the fast Attack current.

The modes where the inputs go from shorted to unshorted are :

- 1) From Full Power Down either Servo mode (SERVO GATE active)
- 2) From Full Power Down to Idle mode.

- 3) From Full Power Down to Read mode.
- 4) From Write to Read mode.
- 5) From Write to Idle mode.

The modes where the inputs go from unshorted to shorted are : 1) From Read to Write mode. 2) From any mode to Full Power Down mode.

The modes where the fast attack and decay currents become active are :

- 1) From Full Power Down to Idle mode.
- 2) From Full Power Down to Read mode.
- 3) From Write to Read mode.

Nominally the AGC amplifier outputs will be AC coupled to the Active Filter outputs and then the Active Filter outputs, both Normal and Differential will be AC coupled back to the Pulse Detector block.

Pulse Detector

This block has 4 inputs, 2 fully differential pairs. The CLOCK PATH inputs are a zero crossing detector, zero crossing assumed to occur at the amplitude peaks of the pulses. This input pairs shall be connected to the Active Filter differentiator. The DATA PATH inputs are amplitude (threshold) qualifiers and are to be connected to the Active Filter normal outputs. Call factory for schematic for the recommended connection in the system. Dual threshold comparators are available in the Pulse Detector. If the DEDC bit is set in the DataVth register (ROA), then separate comparisons are done on negative and positive peaks. If the bit is reset, then the polarity of the next pulse to be qualified must be opposite of the last. This check can lead to a 2 bit missing error for just 1 pulse under threshold. The threshold used for comparison is set in the two threshold register DataVth and ServoVth. These register feed the threshold DAC (VTHDAC) which develops the actual floating hysteresis level and thresholds from the input LEVEL (a buffered signal rectified from the filter normal outputs. The hysteresis is always a percentage, of 0.7 the peak to peak swing at DATA PATH inputs, and is accurate from 10 to 80 % with a 1 % accuracy. The floating hysteresis generator also has a time constant which is developed from the components connected to SERVO TC RES, DATA TC RES, LEVEL, and LEVEL REF V. This time constant is, in effect, a time domain filter implemented in the qualifier channel that has the purpose to realize an envelope detector on the rectified signal feeding the DATA PATH inputs. The two constant is changed depending on SERVO GATE state.. Recommended values for Rext on SERVO TC RES and DATA TC RES is TBD ; for Cext on LEVEL and LEVEL REF V it is TBD. The output of the Pulse Detector block is READ DATA I/O, and this pin is active ONLY in the Idle and Servo modes. It is an approximately 24 nsec negative going TTL com-

patible data pulse. The PD- Test bit of the register CA controls this output being active. NORMAL operation is for this bit to be reset, but for testing the Data Separator as an input, it should be set.

Servo Demodulator

When in Servo mode all circuitry not needed to acquire embedded servo position information is deactivated, the AGC loop is switched to the servo BYP capacitor, the $\overline{\text{READ DATA I/O}}$ output is activated, the $\overline{\text{SERVO TC RES}}$ Servo time constant setting resistor is connected to LEVEL REF V, and the hysteresis threshold level is set to the Servo threshold. Three servo control inputs, $\overline{\text{LATCH CAP A}}$, $\overline{\text{LATCH CAP B}}$, and $\overline{\text{RESET CAP A/B}}$ control the servo peak sample and hold functions. When HOLD SERVO AGC is deasserted, the servo charge pump drives the SERVO BYP hold capacitor. The current magnitude and direction is determined by the formula :

$$I_{\text{byp2}} = g_{m1} \cdot (V_{\text{set}} - V_a(\text{DIN}) - V_b(\text{DIN}))$$

where : $g_{m1} = 640 \mu\text{A/Vpp}$

$$V_{\text{set}} = 1.0\text{Vpp}$$

$V_a/b(\text{DIN})$ pp = peak to peak A or B servo pattern signal voltages across DATA PATH and DATA PATH.

When $\overline{\text{SERVO GATE}}$ is deasserted, there is an automatic 1 usec break before make switch in an action before the capacitor on the DATA BYP pin is reconnected to the AGC gain control.

The POSITION OUT pin outputs a voltage equal to the difference between HOLD CAP A and HOLD CAP B referenced to SERVO REF V.

The DATA BYP and SERVO BYP capacitor voltages will be held constant (subject to leakage current) during sleep mode, when the respective HOLD DATA AGC and HOLD SRV AGC signals are low, and when they are not being used to control the AGC loop.

Test bits and modes

The $\overline{\text{FDCT}}$ bit in the Control A register forces the Charge pump into the fast decay (or 0.08 mA current) mode. This bit should be set during power up in a normal system. The PD_Test bit stands for Pulse Detector Test and should be reset, so that MULT TP1 outputs Delayed Read Data (DRD), and MULT TP2 outputs the Data Separator VCO (divided by two).

Programmable Active Filter

The outputs of the AGC Amplifier of the Pulse Detector block are normally AC coupled to inputs of the Active Filter. The low-pass portion of the active filter is to bandlimit noise. The FCutoff register is used to set the cutoff frequency of this portion. The filter type is a 7 pole 0.05 degree equiripple linear phase error low-pass. Shaping

response may also be introduced, via the boost equalization available. This is done to account for deficiencies in the recording process. The FBoost register sets the amount and polarity of boosting the cutoff frequency in the Active Filter. The amount set is contained in the FB register. The boost is accomplished by a two pole high-pass feed forward section in parallel with the low-pass filter. A differentiator is also part of the Active Filter major block to turn the recovered peaks into zero crossing. The differentiator is a single pole, single zero active type. The Active Filter block has 2 outputs. One set is the differential outputs from the low-pass/equalization portion. The other set is the differential outputs of differentiator portion. Both sets of the outputs have matched delays to maintain timing integrity when re-entering the Pulse Detector major block. The current reference for the FC and FB DAC is developed off of the EF IREF input. The recommended value of the resistor at EF IREF is : $12 \text{Kohm} \pm 1\%$.

The normalized low-pass transfer function is : (i.e. $\omega_c = 2\pi f_c = 1$) are: (see Fig. 2 for reference)

$$\frac{V_{\text{norm}}}{V_i} = \frac{(1 - Ks^2 + 0.75928)}{D(s)} \cdot AN$$

The normalized differentiator transfer function is :

$$\frac{V_{\text{diff}}}{V_i} = \frac{(1 - Ks^2 + 0.75928) \cdot s \cdot 1.16099}{D(s)} \cdot AD$$

$$\text{where } D(s) = (1 + s + 1.27936 + s^2 \cdot 0.75928) \cdot (1 + s \cdot 0.52247 + s^2 \cdot 0.33882) \cdot (1 + s \cdot 0.21323 + s^2 \cdot 0.1862) \cdot (1 + s \cdot 1.16099)$$

AN and AD are adjusted for a gain of 2 at $f_s = (2/3)FC$.

Frequency Synthesizer

The Frequency Synthesizer block is used to develop source recording frequencies for writing data in the system. It is Phase Lock Loop based circuit with divide counters set by registers loaded from the serial interface. The frequency generated, F_{out} , is 3 times the HOST data rate in Mbits/sec, and is 2 times the CODE data rate of pulses written on the disks. The resolution of the frequency is 1%. The filter to the PLL is external, and fully differential on the pins $\overline{\text{FREQ SYN FLT}}$ and $\overline{\text{FREQ SYN FLT}}$. A second order filter is recommended. The F_{out} frequency is used in Read, Write and Idle modes as the reference for the Data Separator PLL. If the ET bit of Control A register is set in these modes the FRE OUT TP pin will output the Synthesizer clock F_{out} . Setting this bit in Read mode is not recommended in order to reduce jitter and decrease power dissipation. To set the frequency, the input REFERENCE FIN is fed to the divide by N+1 counter, and this counter output is the reference input of the Frequency

Figure 2: Normalized block diagram for filter

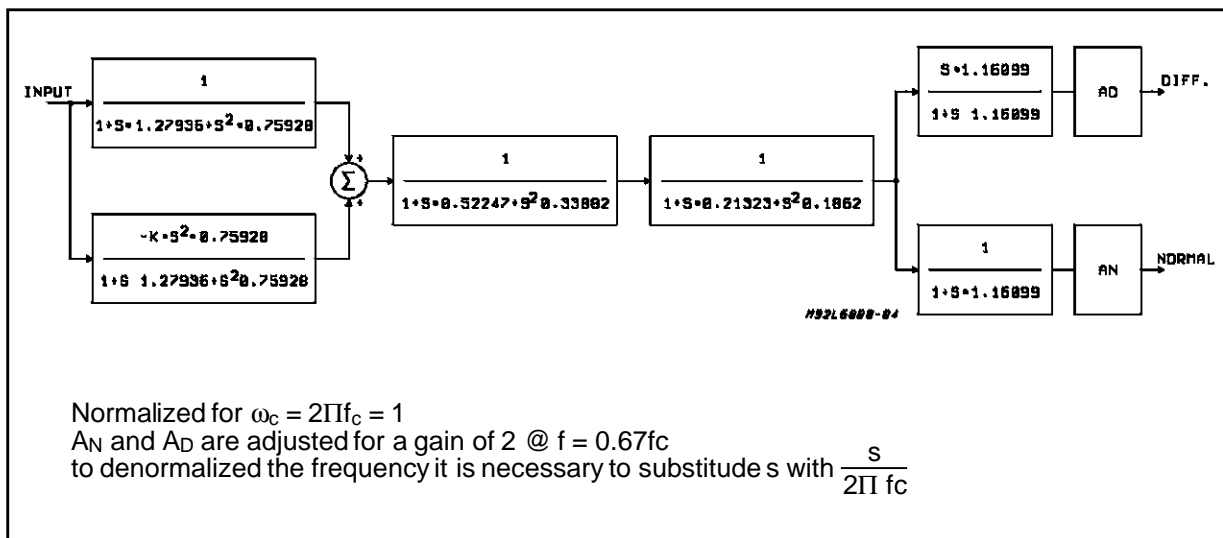

Synthesizer phase comparator. The Frequency Synthesizer VCO is fed to divide by M+1 counter, and the counter output is the other phase comparator input.

This develops the frequency:

$$F_{out} = \frac{(M+1)}{(N+1)} F_{REF}$$

Note : For the new value in the M and N registers to be transferred to their respective counters, the VCO Center Frequency DAC register must be loaded with its value. This means the normal order of register writes to change the Frequency Synthesizer output frequency would be:

- 1) Write M and/or N register with its (their) new value (s).
- 2) Write the VCO Center Frequency register with its new value.

The RREF is chosen to set the frequency range of both the FDSVCO and the DSVCO.

CLOCKS AND MODES

WRITE GATE	READ GATE	VCO REF	RRC	DECCLK	ENCCLK	MODE
0	0	Fout/2	Fout/3	Fout/2	Fout/2	IDLE
0	1	DRD	VCO/3	VCO/2	Fout/2	READ
1	0	Fout/2	Fout/3	Fout/2	Fout/2	WRITE

Notes: 1 Until the VCO locks to the new source, the VCO/2 entries will be FREQ OUT TP/2.

2: Until the VCO locks to the new source, the VCO/3 entries will be FREQ OUT TP/3

3: WRITE GATE = READ GATE = 1 is undefined and illegal

Data Separator

The data separator circuit is a complete 1.7 RLL ENDEC data recovery circuit. In the read mode, the circuit performs data synchronization, sync field search and detect, address mark detect, Read-back clock generation and data decoding. In the write mode, the circuit converts NRZ data into the (1.7) RLL format described in the Table

1, performs write precompensation, generates the preamble field and inserts address marks as requested.

The data rate used for recovery is determined by the VCO Center Frequency DAC, otherwise called the PLL Control DAC and the external resistor RREF connected to the pin DS IREF and Data Separator GND. The differential filter connected to the pins DATA SEP FLT and DATA SEP FLT determine the loop gain, bandwidth and damping. A second order filter is recommended in most systems, and the filter will determine the system characteristics. The phase comparator of the Data Separator PLL utilizes phase only comparisons when locked to the disk data stream, only making a phase comparison when a data bit is available. In the frequency comparison mode, a phase compare is done to every VCO transition. This latter is done whenever the PLL is powered on and data is NOT being read from the disk. By acquiring both phase and frequency lock to the input reference frequency and utilizing a zero phase restart technique, VCO transients are minimized and false lock to READ DATA is eliminated. The two control inputs READ GATE and WRITE GATE directly switch the operations of the Data Separator. In addition, there are two further submodes split between the Hard Sector mode of operation and the Soft Sector. Hard Sector operation is selected by resetting the SOFT bit control B register via the serial interface. The assertion of READ GATE causes the Data Separator to enter the lock up sequence, and Read mode. Read mode continues until READ GATE deassertion. The assertion of WRITE GATE causes the Separator to enter Write mode. WRITE GATE should not be deasserted until the last bit is written on the disk. Assertion of BOTH signals at once is illegal and will lead to unpredictable results.

1.7 RLL ENCODING

Previous RLL Code Word Last Bits		NRZ Data Bits				RLL Code Bits		
		Present	Next					
X	0	1	0	0	X	1	0	1
X	0	1	0	1	X	1	1	0
X	0	1	1	0	0	0	1	0
X	0	1	1	*	*	1	0	0
1	0	0	0	0	X	0	0	1
1	0	0	0	1	X	0	0	0
0	0	0	1	0	X	0	0	1
0	0	0	1	1	X	0	0	0
X	1	0	0	0	X	0	0	1
X	1	0	0	1	X	0	1	0
X	1	0	1	0	0	0	1	0
X	1	0	1	*	*	0	0	0
Y2'	Y3	D1	D2	D3	D4	Y1	Y2	Y3

X = Do Not Care
* = Not All Zeros
1, 7 RLL CODE SET

Read Mode

The phase comparator enters its phase only compare mode after three cycles of a 3T pattern. This means that the leading edge of READ DATA arms the comparator and then the phase comparison is done between the trailing edge of READ DATA and the rising edge of the closest VCO cycle. The time between the two READ DATA edges is 1 VCO cycle, or 1/3 bit cell and is generated by an internal one-shot and the PLL Control DAC.

The Window Shift function of the L6000 is provided for testing purposes, and advanced recovery from read errors. To shift the bit position from its nominal centered position in the decode window, a value is written to the WinShift register via the serial interface. The shift value will take effect after SERIAL ENABLE is deasserted. The direction is determined by the Direction bit in the register. See the Register Definition section for the complete set of values and their effect. To do the Window shift function, the WinShift register sets a current in the WS DAC which then adds or subtracts current in the 1/2 VCO cycle delay for the Data Synchronizer. This then changes the position of the trailing edge of the READ DATA pulse at the Synchronizer ONLY. Since the edge position doesn't change relative to the VCO at the phase lock is unaffected, and only the bit position is moved inside the decode window in the Synchronizer.

The VCO has a zero phase restart feature which allows for very quick acquisition of the READ DATA phase being recovered from the disk. The VCO is kept at frequency Fout during Idle mode, and when Preamble is detected, the zero phase restart first turn OFF the VCO, then restarts it in phase with the first received data bit.

ABOVE VOLTAGE MONITOR

The above voltage bit is used to actively center the bit in the window by trimming the operating current of PLL Control DAC to its midpoint of operation.

To optimize this time from temperature and process variations, the Above Voltage check should be performed on a periodic (at least every frequency switch) basis. This will center the operating point of the VCO and set the 1/2 VCO cycle delay closest to nominal.

Above Voltage monitor bit (Register 4, B7):

This feature allows the drive microprocessor to set the VCO to the center of its capture range, and to remove any offset error from the delay one-shots in the Data Separator. By changing the setting of the VCO center register (04), the drive microprocessor can maximize the loop lock range (and minimize margin timing error at power up). The comparator driving this bit allows for setting the VCO DAC (Register 04) to place the Data Separator VFO to its mid-point of operation. It is intended for use a power-up time calibration, but can be done at any time power is applied to the L6000. The microprocessor which loads the register values monitors this bit in the following algorithm:

1. Set the Numerator and Denominator values for the first data rate in Register 0E and 06, respectively.
2. Write the nominal value chosen to the VCO, DAC, Register 04.
3. Read the Above Voltage bit: if it is HIGH, decrease the value in Register 04 by 1. If it is LOW, increase the value in Register 04 by 1.
4. Read the bit again; if it has reversed polarity store the value written to Register 04 as the Calibrated VCO DAC Register 2 value for future use when in that zone. If it has not, repeat step 3.
5. Repeat the same procedure (steps 1 to 4) for all zones and store the Calibrated Register 2 values for future use.

Soft Sector - Read Back

The assertion of READ GATE initiates the lock up sequence. The lock up sequence proceeds as follows:

1. An Address Mark is searched for. The Address Mark consists of two sets of 7 0s, 1, 11 0s, 1, 11 0s, 1. When the L6000 detects 6 0s, then detects 9 0s, TWICE, it generates the Address Mark found condition, and asserts ADDR MARK DET. ADDR MARK DET will remain asserted until the end of the Read operation. If the 9 0s are not detected within 5 data bits of the 6 0s field, the circuit will auto-

matically restart the Address Mark search.

2. Preamble is recognized upon the presence of three cycles of a 3T pattern.
3. Recognition of preamble switches phase detector input from the Fout divide by 2 reference clock to delayed readback data (DRD)
4. The VCO is zero phase error restarted to the 3 x 3T readback pulse seen after switching of the phase detector input.
5. Depending on the state of the GS bit in the Control B register:

If GS is set:

- a) The IC will count 8 more data bits (3T periods) and then will decrease the charge pump current to 1/3 its lock up value. After 8 more data bits, the data Synchronizer starts to decode NRZ. The switchover for READ REF CLOCK from Fout divided by 3 to VCO divided by 3 is made, without glitches.

If GS is reset:

- b) The IC will count 16 more data bits (3T periods) and the charge pump current is NOT changed. All operations as in GS set then occur. Decoding specifically starts later by 8 bits if GS is reset.

6. RRC clock is output from the pin READ REF CLOCK and decoded data is output from the pin READ NRZ OUTPUT until READ GATE deasserts.

Hard Sector - Read Back

In Hard Sector, the SOFT bit in Control B register has been reset. The lock up sequence proceeds as follows:

1. An Address Mark is not searched for and ADDR MARK DET remains inactive.
2. Preamble is recognized upon the presence of three cycles of a 3T pattern.
3. Recognition of preamble switches phase detector input from the Fout divide by 2 reference clock to delayed readback data (DRD).
4. The VCO is zero phase error restarted to the first readback pulse seen after switching of the phase detector input.
5. The rest of the Read mode sequence is identical to the Soft Sector submode.

Window Shift Control

Window shift magnitude is set by the value in the Window Shift (WS) register. The register bits are defined as follows:

Bit	Symbol	Description
0	WS0	Window Shift LSB
1	WS1	Window Shift
2	WS2	Window Shift
3	WS3	Window Shift MSB
4	WSD	Window Shift Direction
5	WSE	Enable Window Shift
6	TDACO	Control Bit for DAC Testing
7	TDAC1	Control Bit for DAC Testing

WSD - Window Shift direction control

0 ≥ Early window (+TS)

1 ≥ Late window (-TS)

Window Shift magnitude control bits:

WS3	WS2	WS1	WS0	Shift Magnitude (% of the decode window)
1	1	1	1	No shift
1	1	1	0	2% Minimum shift
1	1	0	1	4%
1	1	0	0	6%
1	0	1	1	8%
1	0	1	0	10%
1	0	0	1	12%
1	0	0	0	14%
0	1	1	1	16%
0	1	1	0	18%
0	1	0	1	20%
0	1	0	0	22%
0	0	1	1	24%
0	0	1	0	26%
0	0	0	1	28%
0	0	0	0	30% Maximum shift

for example the shift magnitude corresponding to 2% at 10 Mbit/s data rate is 0.667ns. This is 2% of TVCO since the decode window is 2*TVCO. Its tolerance is ±25%. WSE, WSD, WS3, WS2, WS1, and WS0 are programmed through the serial port during the idle or write mode.

Write Mode

Write mode takes WRT DATA NRZ IN and WRITE CLOCK as input, which this mode then encodes to (1,7) RLL format pulse stream. Again, there is a SOFT and HARD sector mode for Writes. WRITE GATE must be asserted no less than 1 RRC clock period AFTER READ GATE has been deasserted. This is to allow for clock deglitching. There is a register which becomes important only during Write Mode: the Write Pre-compensation register (R0D). If the WPE bit is set, the data being written to the disk will be pre-compensated by the magnitude specified, and according to the algorithm in the following Table.

Soft Sector

The write operation sequence is:

1. WRITE GATE input is asserted and WRT DATA NRZ IN should be a pattern of 80H or FFH followed by 8 bytes of 0. This is to allow

for the generation of the Address Mark and 19 cycles 3T patterns of preamble (the preamble's minimum length).

2. WRITE CLOCK should be present and READ REF CLOCK can be used if the propagation delay relative to WRT DATA NRZ IN is short.
3. First TWO Address Marks of 7 0s, 1, 7 0s, 1, 11 0s, 1, 11, 0s are output from the WRITE DATA pin.
4. Next 19 3T patterns (0 1 0) are written.
5. At this point, WRT DATA NRZ IN should be active and inputting the disk data to be written. For a longer Preamble, hold WRT DATA NRZ IN low and more 3T patterns will be generated.
6. WRITE GATE must be held asserted until all data is output from the (1, 7) Encoder. There is a maximum of 15 bits delay, so WRITE GATE should not deassert until after data has been flushed from the Encoder.

Hard Sector - Write

The Hard Sector write operation is identical to the Soft sector, except that at the start, no Address Mark is generated. WRT DATA NRZ IN should be held low (rather than have 80 or FF at the start).

The appropriate tables for write precompensation are:

WRITE PRECOMPENSATION ALGORITHM

RLL Bit Pattern:					Compensation
N-2	N-1	N	N+1	N+2	BIT N
1	0	1	0	1	NONE
0	0	1	0	0	NONE
1	0	1	0	0	EARLY
0	0	1	0	1	LATE

LATE: Bit N is time shifted (delayed) from its normal time position towards the Bit N+1 time position
 EARLY: Bit N is time shifted (Advanced) from its normal time position towards the Bit N-1 time position

Write Precompensation Control

Write precompensation magnitude is set using the Write Precompensation register. The write precompensation register bits are defined as follows:

Bit	Symbol	Description
0	WO	Write Precomp LSB
1	W1	Write Precomp
2	W2	Write Precomp MSB
3	WPE	Write Precomp Enable
4-7	Unused	

W2, W1, WO - Write precomp magnitude control bits:

- 000 > 7x (maximum) shift
- 001 > 6x shift
- 010 > 5x shift
- 011 > 4x shift
- 100 > 3x shift
- 101 > 2x shift
- 110 > 1x shift
- 111 > No shift

Test Mode

This part has a secondary Write mode. When the Direct Write bit is set in the Control B register, the waveform present on the WRT DATA NRZ IN pin is passed directly through the L6000 to the preamp WDI pin. This allows for operations like servowriting to be done with the drive PCB attached to the mechanics. Care should be taken with the bit in normal system operation.

TQFP64 PACKAGE MECHANICAL DATA

DIM.	mm			inch		
	MIN.	TYP.	MAX.	MIN.	TYP.	MAX.
A			1.85			0.073
A1			0.25			0.010
A2	1.30	1.40	1.50	0.051	0.055	0.059
B	0.18	0.23	0.28	0.007	0.009	0.011
C	0.12	0.16	0.20	0.0047	0.0063	0.0079
D			12.60			0.496
D1		10.00			0.394	
D3		7.50			0.295	
e		0.50			0.0197	
E			12.60			0.496
E1		10.00			0.394	
E3		7.50			0.295	
L	0.40	0.50	0.60	0.0157	0.0197	0.0236
L1			1.30			0.052
K	0°(min.), 5°(max.)					

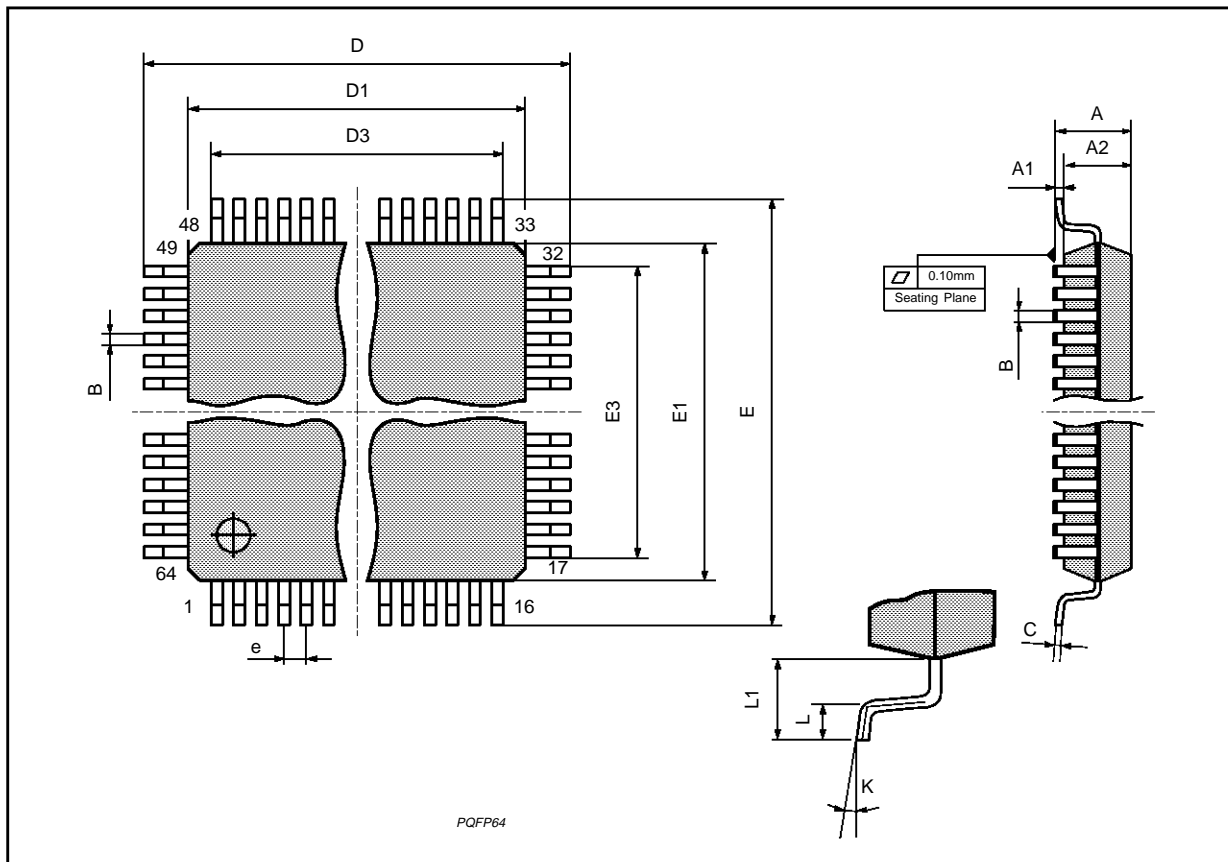

Information furnished is believed to be accurate and reliable. However, SGS-THOMSON Microelectronics assumes no responsibility for the consequences of use of such information nor for any infringement of patents or other rights of third parties which may result from its use. No license is granted by implication or otherwise under any patent or patent rights of SGS-THOMSON Microelectronics. Specifications mentioned in this publication are subject to change without notice. This publication supersedes and replaces all information previously supplied. SGS-THOMSON Microelectronics products are not authorized for use as critical components in life support devices or systems without express written approval of SGS-THOMSON Microelectronics.

© 1994 SGS-THOMSON Microelectronics - All Rights Reserved

SGS-THOMSON Microelectronics GROUP OF COMPANIES

Australia - Brazil - France - Germany - Hong Kong - Italy - Japan - Korea - Malaysia - Malta - Morocco - The Netherlands - Singapore - Spain - Sweden - Switzerland - Taiwan - Thailand - United Kingdom - U.S.A.