

## 28 CHANNEL INK JET DRIVER

ADVANCE DATA

- 40V DMOS OUTPUT BREAKDOWN
- TWO DECODER OPTIONS ARE INCLUDED
- PRECISE OUTPUT ENERGY
- ESD OUTPUT PROTECTION WITH CLAMPING DIODES
- VERY LOW QUIESCENT CURRENT
- PLCC44 OR PQFP44 (10 x 10mm)

### DESCRIPTION

The L6450 is realized in Multipower BCD Technology which combines isolated DMOS power transistors with CMOS and Bipolar circuits on the same IC. By using mixed technology it has been possible to optimize the logic circuitry and the power stage to achieve the best possible performances.

Intended to be used in ink jet Printer Applications as 4 to 28 (2 x 14) or 3 to 28 (4 x 7) lines selectable decoder/driver, the L6450 device driver has the advantages of low power CMOS inputs and logic, with 28 high current and high voltage DMOS outputs capable of sustaining a maximum of 40V.

On system power up the output drivers are locked out using the chip enable function; four enable in-

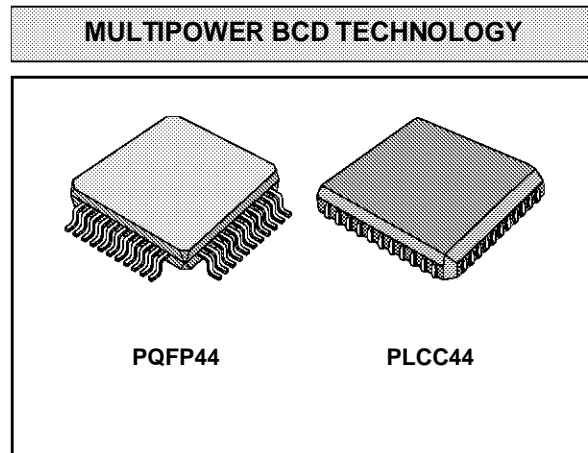

puts are available for the different driver banks.

An internal power-on system is implemented in order to avoid wrong output commutation during the supply voltage transients.

Using a mask option during manufacturing allows a different decoding.

Control of the energy delivered to the print head is made by means of a special circuitry.

All driver outputs are capable of withstanding a contact discharge of  $\pm 8\text{KV}$  with the IC biased.

### BLOCK DIAGRAM (case of 4 bit)

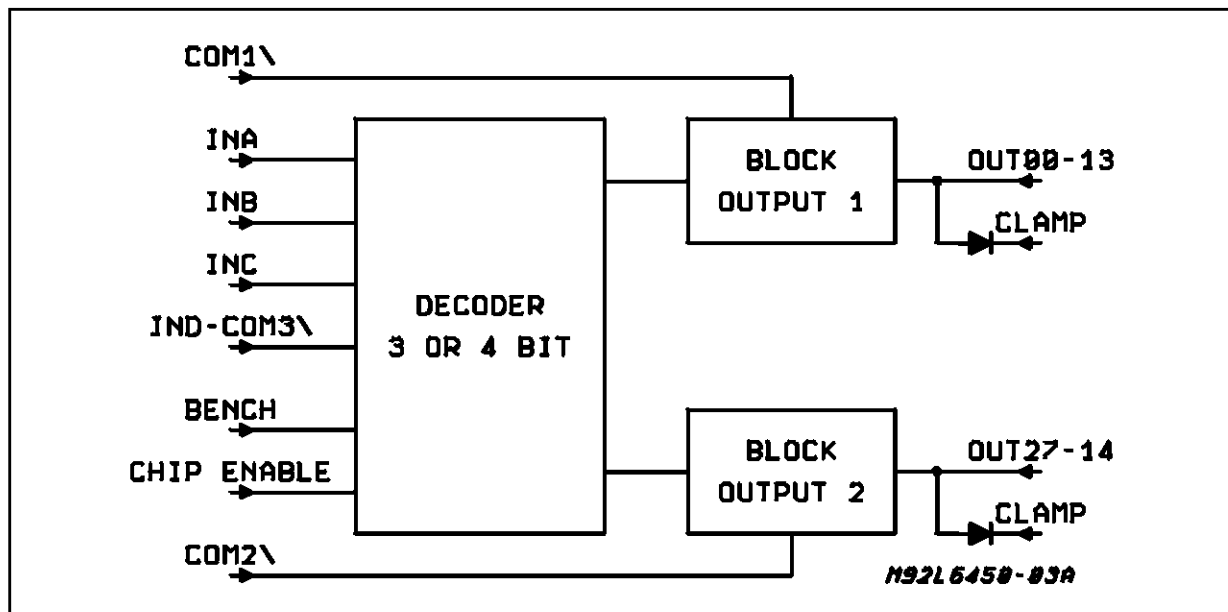

BLOCK DIAGRAM (case of 3 bit)

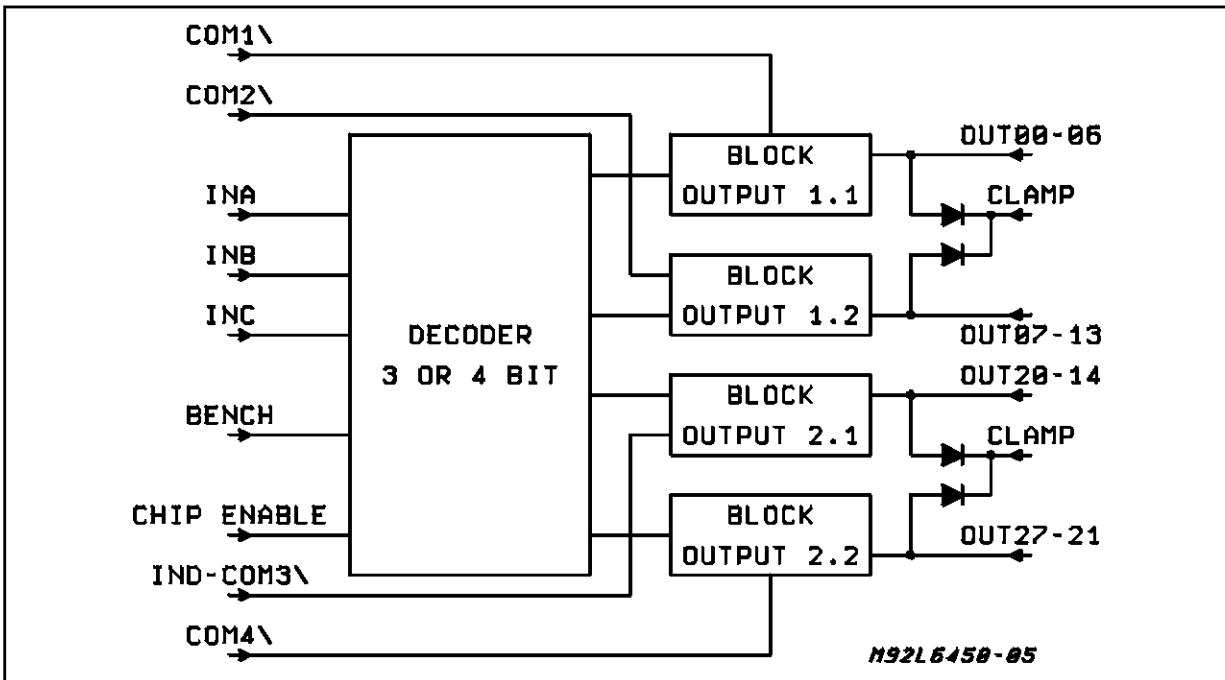

PQFP44 PIN CONNECTION (Top view)

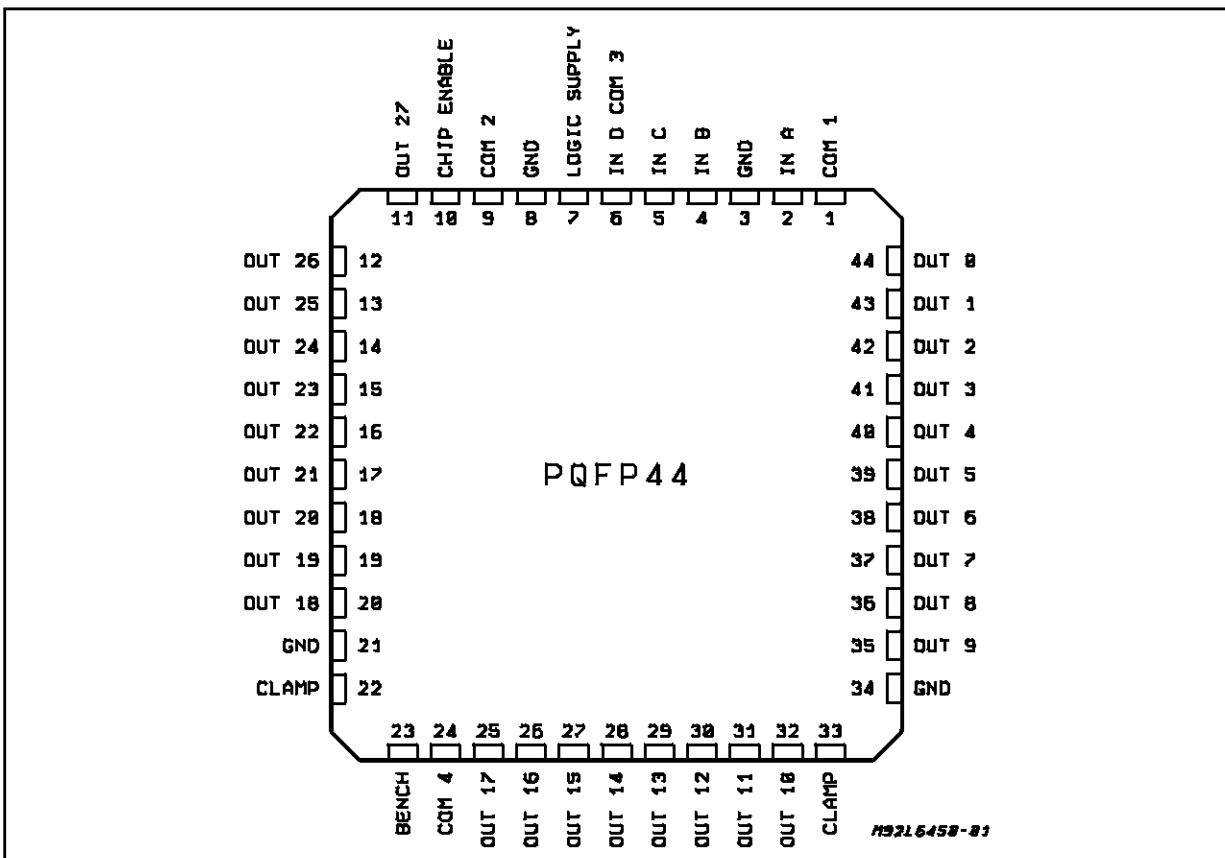

## PLCC44 PIN CONNECTION (Top view)

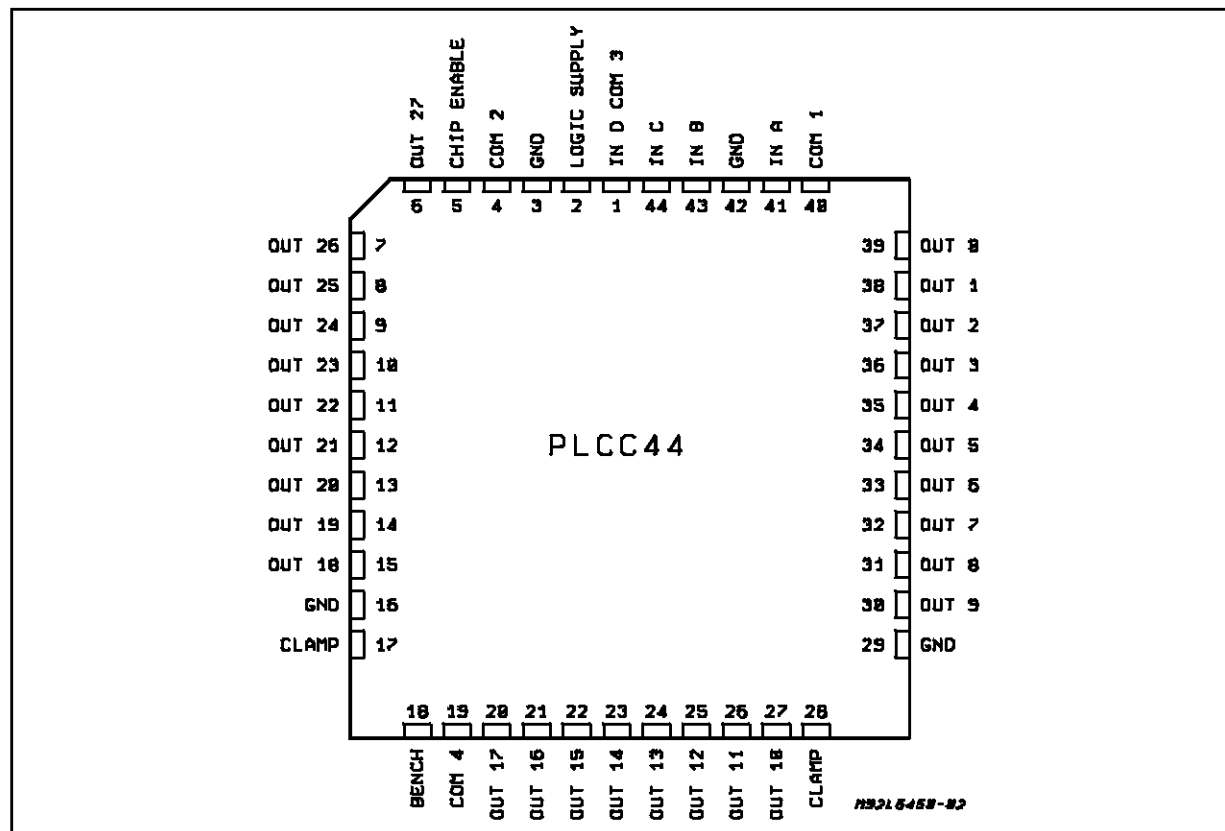

## PIN FUNCTIONS

Name	Function
V <sub>DD</sub>	5V Logic Supply.
GND	Logic and Power Ground.
OUT0 to OUT27	DMOS Outputs.
CLAMP	This pins have to be connected to the power supply voltage of the head resistors, each of the output DMOS have their drain connected with the anode of a protection diode, all the catodes of the protection diodes are collected to the pins clamp. If the CLAMP pins are not connected to the power, the device is not supplied.
INA, INB, INC, IND	Decoder inputs. The input IND shares the pin with the other input $\overline{\text{COM3}}$ , the two different functions are selected by the pin Bench.
$\overline{\text{COM1}}$ , $\overline{\text{COM2}}$ , $\overline{\text{COM3}}$ , $\overline{\text{COM4}}$	A low logic input on this pins enable the outputs selected by the decoder inputs according to the logic level of the pin bench. The input COM3 shares the pin with the other input IND, the two different functions are selected by the pin Bench.
CHIP ENABLE	A logic high enable the chip.

## THERMAL DATA

Symbol	Parameter	PQFP44	PLCC44	Unit
R <sub>th j-amb</sub>	Thermal Resistance Junction-Ambient	Max. 55 (*)	65 (*)	°C/W

(\*) device mounted on PCB.

## ABSOLUTE MAXIMUM RATINGS

Symbol	Parameter	Value	Unit
V <sub>OUT</sub>	Output Voltage	40	V
V <sub>CLAMP</sub>	Output Clamping Voltage	40	V
I <sub>OUT</sub>	Output Continuous Current	0.8	A
I <sub>PEAK</sub>	Output Peak Current (with duty cycle = 10% T <sub>ON</sub> = 4μs)	2	A
T <sub>J</sub>	Junction Temperature	150	°C
V <sub>DD</sub>	Logic Supply Voltage	7	V
V <sub>IN</sub>	Input Voltage Range	-0.3V to V <sub>S</sub> +0.3	V
T <sub>amb</sub>	Operating Temperature Range	0 to 70	°C
T <sub>stg</sub>	Storage Temperature Range	-55 to 150	°C

D.C. ELECTRICAL CHARACTERISTICS at T<sub>amb</sub> = 25°C, V<sub>DD</sub> = 5V, V<sub>clamp</sub> = 18V (unless otherwise specified).

Symbol	Parameter	Test Condition	Min.	Typ.	Max.	Unit
V <sub>DD</sub>	Logic Supply Voltage		4.75	5	5.25	V
V <sub>CLAMP</sub>	Clamping Voltage		9		38	V
V <sub>IL</sub>	Low Level Input Voltage				1.2	V
V <sub>IH</sub>	High Level Input Current		V <sub>DD</sub> -1.2			V
I <sub>LL</sub>	Low Level Input Current	V <sub>IN</sub> = V <sub>IL</sub>			-200	μA
I <sub>LH</sub>	High Level Input Current	V <sub>IN</sub> = V <sub>IH</sub>			10	μA
I <sub>DD</sub>	Logic Supply Current	(Independent from the output conditions)			5	mA
V <sub>OUT</sub>	Output Saturation Voltage	T <sub>j</sub> 25 °C D.C. 0.4A T <sub>j</sub> 25 °C D.C. 0.5A T <sub>j</sub> 90 °C D.C. 0.4A T <sub>j</sub> 90 °C D.C. 0.5A		0.9 1.1 1.4 1.7		V V V V
ΔV <sub>CE</sub>	Output saturation absolute voltage variation around the typ. values for extended temperature ranges	T <sub>j</sub> = 25°C to 90°C D.C.: 0.4A T <sub>j</sub> = 25°C to 90°C D.C.: 0.5A			±0.2 ±0.25	V V
R <sub>DS ON</sub>				2.2		Ω

A.C. ELECTRICAL CHARACTERISTICS at T<sub>amb</sub> = 25°C, V<sub>DD</sub> = 5V.

Symbol	Signal Name	Parameter	Test Condition	Min.	Typ.	Max.	Unit
T <sub>S</sub>	INA, INB, INC, IND Vs COMn	SET - UP Time		30			ns
T <sub>H</sub>	INA, INB, INC, IND Vs COMn	HOLD Time		0			ns
T <sub>on</sub>	COM1,2,3,4 Vs OUT 0 to N	TURN - ON Time	I <sub>OUT</sub> = 0.5A, R <sub>L</sub> = 39Ω T <sub>j</sub> = 25 to 90°C		150		ns
T <sub>off</sub>	COM1,2,3,4 Vs OUT 0 to N	TURN - OFF Time	I <sub>OUT</sub> = 0.5A, R <sub>L</sub> = 39Ω T <sub>j</sub> = 25 to 90°C		150		ns
t <sub>r</sub>		Rise Time			100		ns
t <sub>f</sub>		Fall Time			100		ns
T <sub>wout</sub>		Output Pulse Width	T <sub>win</sub> = 3.5μs R <sub>L</sub> = 40Ω I <sub>OUT</sub> = 0.5A	- 20	T <sub>win</sub>	+ 80	ns
ΔP <sub>D</sub>		Maximum allowable variation of the output power transmitted by each driver to the resistive load	R <sub>L</sub> = 39Ω V <sub>CLAMP</sub> = 18V			±4	%

Figure 1: Timing Waveforms

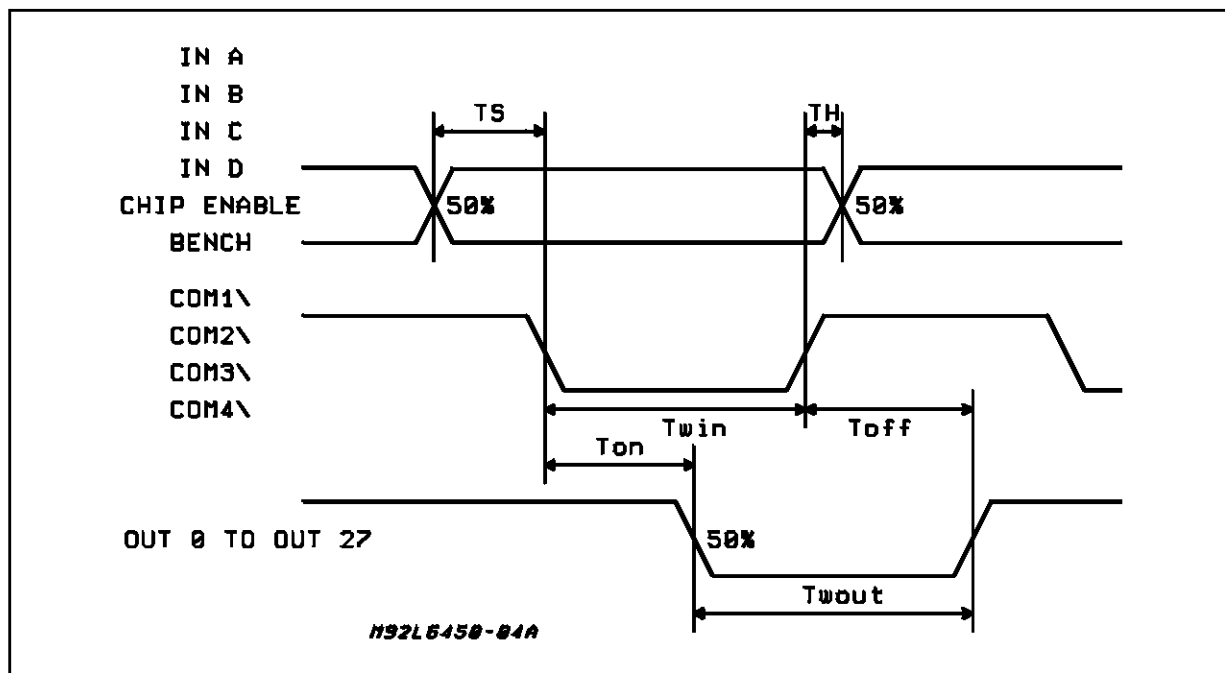

**OUTPUT SELECTION**

1) Decoder Truth Table when the BENCH = HIGH;  
 IND/COM3 = is selected as input decoder ind;  
 COM1 = a low input enable the OUT0 to OUT13;  
 COM2 = A Low Input Enable the OUT14 to OUT27

IND	INC	INB	INA (LSB)	OUTPUTS
0	0	0	0	0.27
0	0	0	1	1.26
0	0	1	0	2.25
0	0	1	1	3.24
0	1	0	0	4.23
0	1	0	1	5.22
0	1	1	0	6.21
0	1	1	1	7.20
1	0	0	0	8.19
1	0	0	1	9.18
1	0	1	0	10.17
1	0	1	1	11.16
1	1	0	0	12.15
1	1	0	1	13.14
1	1	1	0	ALL OFF
1	1	1	1	ALL OFF

2) Decoder Truth Table when the BENCH = LOW;  
 IND/COM3 = is selected as COM3  
 COM1: A Low Input Enable the OUT0 to OUT6  
 COM2: A Low Input Enable the OUT7 to OUT13  
 COM3: A Low Input Enable the OUT14 to OUT20  
 COM4: A Low Input Enable the OUT21 to OUT27

INC	INB	INA (LSB)	OUTPUTS
0	0	0	0, 7, 27, 20
0	0	1	1, 8, 26, 19
0	1	0	2, 9, 25, 18
0	1	1	3, 10, 24, 17
1	0	0	4, 11, 23, 16
1	0	1	5, 12, 22, 15
1	1	0	6, 13, 21, 14
1	1	1	ALL OFF

# L6450

Figure 2: Application Circuit

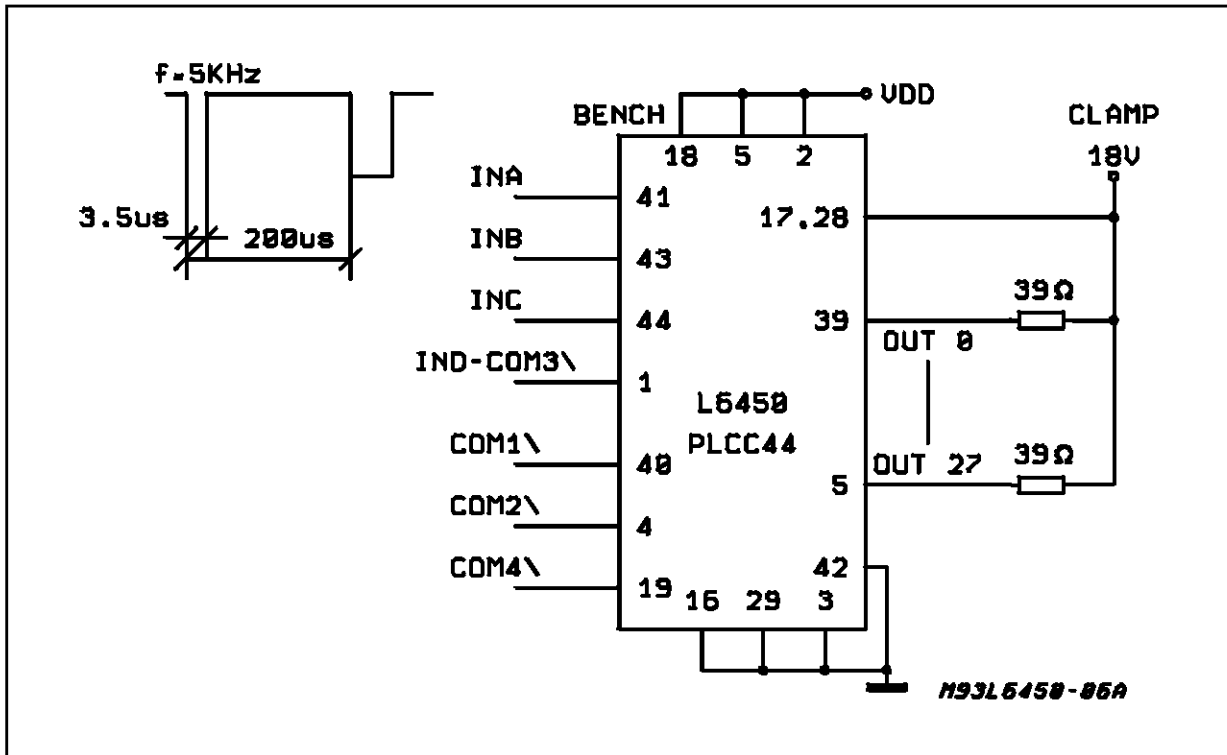

## PQFP44 (14 x 14) PACKAGE MECHANICAL DATA

DIM.	mm			inch		
	MIN.	TYP.	MAX.	MIN.	TYP.	MAX.
A			3.40			0.134
A1	0.25			0.0098		
A2	2.55	2.80	3.05	0.100	0.110	0.120
B	0.35		0.50	0.0138		0.0197
C	0.13		0.23	0.005		0.009
D	16.95	17.20	17.45	0.667	0.677	0.687
D1	13.90	14.00	14.10	0.547	0.551	0.555
D3		10.00			0.394	
e		1.00			0.039	
E	16.95	17.20	17.45	0.667	0.677	0.687
E1	13.90	14.00	14.10	0.547	0.551	0.555
E3		10.00			0.394	
L	0.65	0.80	0.95	0.025	0.0315	0.0374
L1		1.60			0.063	
K	0°(min.), 7°(max.)					

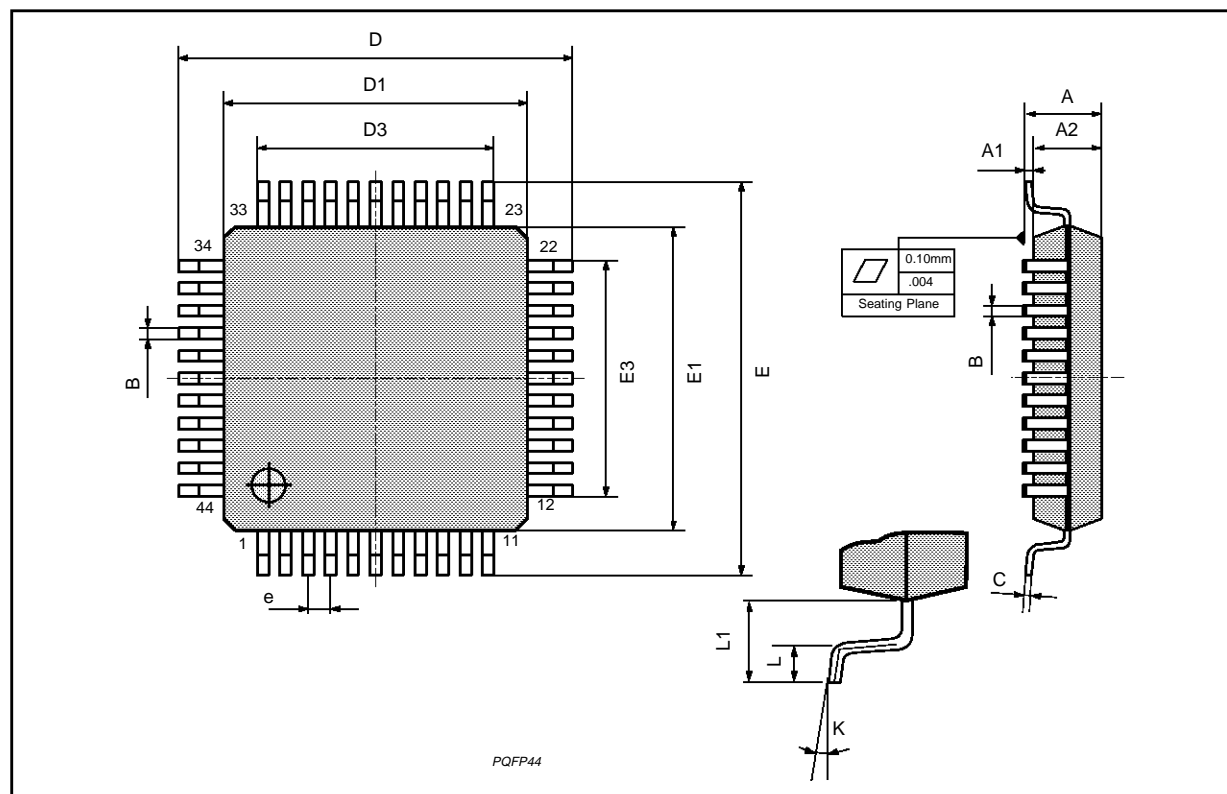

## PLCC44 PACKAGE MECHANICAL DATA

DIM.	mm			inch		
	MIN.	TYP.	MAX.	MIN.	TYP.	MAX.
A	17.4		17.65	0.685		0.695
B	16.51		16.65	0.650		0.656
C	3.65		3.7	0.144		0.146
D	4.2		4.57	0.165		0.180
d1	2.59		2.74	0.102		0.108
d2		0.68			0.027	
E	14.99		16	0.590		0.630
e		1.27			0.050	
e3		12.7			0.500	
F		0.46			0.018	
F1		0.71			0.028	
G			0.101			0.004
M		1.16			0.046	
M1		1.14			0.045	

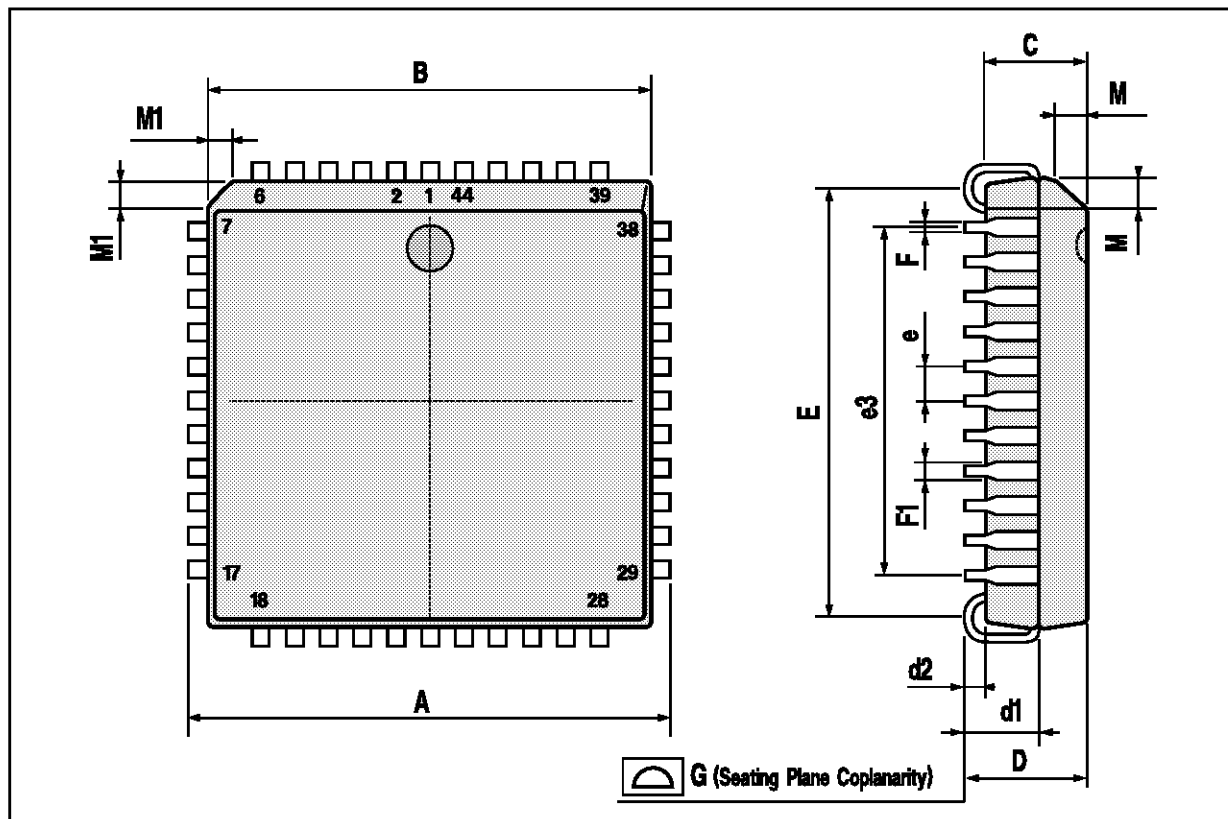

Information furnished is believed to be accurate and reliable. However, SGS-THOMSON Microelectronics assumes no responsibility for the consequences of use of such information nor for any infringement of patents or other rights of third parties which may result from its use. No license is granted by implication or otherwise under any patent or patent rights of SGS-THOMSON Microelectronics. Specifications mentioned in this publication are subject to change without notice. This publication supersedes and replaces all information previously supplied. SGS-THOMSON Microelectronics products are not authorized for use as critical components in life support devices or systems without express written approval of SGS-THOMSON Microelectronics.

© 1994 SGS-THOMSON Microelectronics - All Rights Reserved

SGS-THOMSON Microelectronics GROUP OF COMPANIES

Australia - Brazil - France - Germany - Hong Kong - Italy - Japan - Korea - Malaysia - Malta - Morocco - The Netherlands - Singapore - Spain - Sweden - Switzerland - Taiwan - Thailand - United Kingdom - U.S.A.