

L78M00ML Series

T-58-11-13



3100

Monolithic Linear IC

5 to 24V 0.5A 3-Pin Voltage Regulator

©2607

Features

- Output voltage L78M05ML:5V L78M06ML:6V L78M07ML:7V L78M08ML:8V
L78M09ML:9V L78M10ML:10V L78M12ML:12V L78M15ML:15V
L78M18ML:18V L78M20ML:20V L78M24ML:24V
- Output current: 500mA
- On-chip thermal protector
- On-chip overcurrent limiter
- On-chip ASO protector
- TO-220ML package facilitating easy mounting and thermal design
- Micaless version that insulates the package from each pin, requiring no insulation for mounting

[Common to L78M00ML series]

Maximum Ratings at Ta=25°C

				unit
Maximum Supply Voltage	V _{CC} max	Pin1	35	V
Allowable Power Dissipation	Pd max		2	W
	Pd	(Tc=25°C)	7.5	W
Operating Temperature	Topg		-20 to +80	°C
Storage Temperature	Tstg		-40 to +150	°C

[L78M05ML]

Recommended Operating Conditions at Ta=25°C

			unit
Input Voltage	V _{IN}	7.5 to 20	V
Output Current	I _{OUT}	5 to 500	mA

Operating Characteristics at Ta=25°C, V_{IN}=10V, I_{OUT}=350mA,

			min	typ	max	unit
Output Voltage	V _{OUT}	Tj=25°C	4.8	5.0	5.2	V
Line Regulation	ΔV _{oline}	Tj=25°C, 7V ≤ V _{IN} ≤ 25V, I _{OUT} =200mA	3.0	50	mV	
		Tj=25°C, 8V ≤ V _{IN} ≤ 20V, I _{OUT} =200mA	1.0	25	mV	

Continued on next page.

Equivalent Circuit

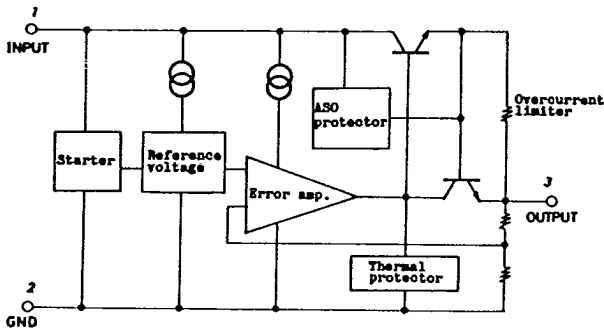

Case Outline 3100-S3TR (unit:mm)

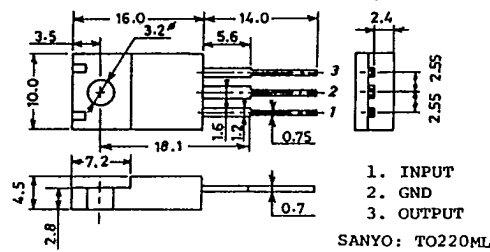

9147TA, TS No.2607-1/7

513

L78M00ML Series

T-58-11-13

Continued from preceding page.

			min	typ	max	unit
Load Regulation	ΔV_{load}	$T_j=25^\circ\text{C}, 5\text{mA} \leq I_{\text{OUT}} \leq 500\text{mA}$ $T_j=25^\circ\text{C}, 5\text{mA} \leq I_{\text{OUT}} \leq 200\text{mA}$			100	mV
Output Voltage	V_{OUT}	$7\text{V} \leq V_{\text{IN}} \leq 20\text{V}, 5\text{mA} \leq I_{\text{OUT}} \leq 350\text{mA}$	4.75		5.25	V
Current Dissipation	I_{CC}	$T_j=25^\circ\text{C}$		4.5	6.0	mA
Current Dissipation Variation (Line)	ΔI_{CCline}	$8\text{V} \leq V_{\text{IN}} \leq 25\text{V}, I_{\text{OUT}}=200\text{mA}$			0.8	mA
Current Dissipation Variation (Load)	ΔI_{CCload}	$5\text{mA} \leq I_{\text{OUT}} \leq 350\text{mA}$			0.5	mA
Output Noise Voltage	V_{NO}	$10\text{Hz} \leq f \leq 100\text{kHz}$		40		μV
Ripple Rejection	R_{rej}	$f=120\text{Hz}$ $I_{\text{OUT}}=100\text{mA}$ $8\text{V} \leq V_{\text{IN}} \leq 19\text{V}$ $I_{\text{OUT}}=300\text{mA}$ $T_j=25^\circ\text{C}$	62		80	dB
Minimum Input-Output Voltage Drop	V_{drop}	$I_{\text{OUT}}=350\text{mA}$		2.0		V
Short Current	I_{OS}	$T_j=25^\circ\text{C}, V_{\text{IN}}=35\text{V}, \text{to GND}$		300		mA
Peak Output Current	I_{op}	$T_j=25^\circ\text{C}$		0.7		A

[L78M06ML]

Recommended Operating Conditions at $T_a=25^\circ\text{C}$

		unit
Input Voltage	V_{IN}	8.5 to 21 V
Output Current	I_{OUT}	5 to 500 mA

Operating Characteristics at $T_a=25^\circ\text{C}, V_{\text{IN}}=11\text{V}, I_{\text{OUT}}=350\text{mA}$,
See specified Test Circuit.

			min	typ	max	unit
Output Voltage	V_{OUT}	$T_j=25^\circ\text{C}$	5.75	6.0	6.25	V
Line Regulation	ΔV_{oline}	$T_j=25^\circ\text{C}, 8\text{V} \leq V_{\text{IN}} \leq 25\text{V}, I_{\text{OUT}}=200\text{mA}$ $T_j=25^\circ\text{C}, 9\text{V} \leq V_{\text{IN}} \leq 20\text{V}, I_{\text{OUT}}=200\text{mA}$		5.0	60	mV
Load Regulation	ΔV_{oload}	$T_j=25^\circ\text{C}, 5\text{mA} \leq I_{\text{OUT}} \leq 500\text{mA}$ $T_j=25^\circ\text{C}, 5\text{mA} \leq I_{\text{OUT}} \leq 200\text{mA}$		1.5	30	mV
Output Voltage	V_{OUT}	$8\text{V} \leq V_{\text{IN}} \leq 21\text{V}, 5\text{mA} \leq I_{\text{OUT}} \leq 350\text{mA}$	5.7		6.3	V
Current Dissipation	I_{CC}	$T_j=25^\circ\text{C}$		4.5	6.0	mA
Current Dissipation Variation (Line)	ΔI_{CCline}	$9\text{V} \leq V_{\text{IN}} \leq 25\text{V}, I_{\text{OUT}}=200\text{mA}$			0.8	mA
Current Dissipation Variation (Load)	ΔI_{CCload}	$5\text{mA} \leq I_{\text{OUT}} \leq 350\text{mA}$			0.5	mA
Output Noise Voltage	V_{NO}	$10\text{Hz} \leq f \leq 100\text{kHz}$		45		μV
Ripple Rejection	R_{rej}	$f=120\text{Hz}$ $I_{\text{OUT}}=100\text{mA}$ $9\text{V} \leq V_{\text{IN}} \leq 20\text{V}$ $I_{\text{OUT}}=300\text{mA}$ $T_j=25^\circ\text{C}$	59		80	dB
Minimum Input-Output Voltage Drop	V_{drop}	$I_{\text{OUT}}=350\text{mA}$		2.0		V
Short Current	I_{OS}	$T_j=25^\circ\text{C}, V_{\text{IN}}=35\text{V}, \text{to GND}$		300		mA
Peak Output Current	I_{op}	$T_j=25^\circ\text{C}$		0.7		A

[L78M07ML]

Recommended Operating Conditions at $T_a=25^\circ\text{C}$

		unit
Input Voltage	V_{IN}	9.5 to 22 V
Output Current	I_{OUT}	5 to 500 mA

T-58-11-13

L78M00ML Series

Operating Characteristics at Ta=25°C, V_{IN}=12V, I_{OUT}=350mA,
See specified Test Circuit.

			min	typ	max	unit
Output Voltage	V _{OUT}	Tj=25°C	6.72	7.0	7.28	V
Line Regulation	ΔV _{oline}	Tj=25°C, 9V ≤ V _{IN} ≤ 25V, I _{OUT} =200mA	6.0	60		mV
Load Regulation	ΔV _{oload}	Tj=25°C, 10V ≤ V _{IN} ≤ 20V, I _{OUT} =200mA	2.0	30		mV
		Tj=25°C, 5mA ≤ I _{OUT} ≤ 500mA		140		mV
Output Voltage	V _{OUT}	Tj=25°C, 5mA ≤ I _{OUT} ≤ 200mA		70		mV
Output Voltage	V _{OUT}	9V ≤ V _{IN} ≤ 22V, 5mA ≤ I _{OUT} ≤ 350mA	6.6		7.4	V
Current Dissipation	I _{CC}	Tj=25°C	4.6	6.0		mA
Current Dissipation	ΔI _{CCline}	10V ≤ V _{IN} ≤ 25V, I _{OUT} =200mA		0.8		mA
Variation (Line)						
Current Dissipation	ΔI _{CCload}	5mA ≤ I _{OUT} ≤ 350mA		0.5		mA
Variation (Load)						
Output Noise Voltage	V _{NO}	10Hz ≤ f ≤ 100kHz		48		μV
Ripple Rejection	R _{rej}	f=120Hz	58			dB
		10V ≤ V _{IN} ≤ 21V	58	80		dB
		Tj=25°C				
Minimum Input-Output	V _{drop}	I _{OUT} =350mA	2.0			V
Voltage Drop						
Short Current	I _{OS}	Tj=25°C, V _{IN} =35V, to GND	300			mA
Peak Output Current	I _{op}	Tj=25°C	0.7			A

[L78M08ML]

Recommended Operating Conditions at Ta=25°C

			unit
Input Voltage	V _{IN}	10.5 to 23	V
Output Current	I _{OUT}	5 to 500	mA

Operating Characteristics at Ta=25°C, V_{IN}=15V, I_{OUT}=350mA,
See specified Test Circuit.

			min	typ	max	unit
Output Voltage	V _{OUT}	Tj=25°C	7.7	8.0	8.3	V
Line Regulation	ΔV _{oline}	Tj=25°C, 10.5V ≤ V _{IN} ≤ 25V, I _{OUT} =200mA	6.0	60		mV
Load Regulation	ΔV _{oload}	Tj=25°C, 11V ≤ V _{IN} ≤ 20V, I _{OUT} =200mA	2.0	30		mV
		Tj=25°C, 5mA ≤ I _{OUT} ≤ 500mA		160		mV
Output Voltage	V _{OUT}	Tj=25°C, 5mA ≤ I _{OUT} ≤ 200mA		80		mV
Output Voltage	V _{OUT}	10.5V ≤ V _{IN} ≤ 23V, 5mA ≤ I _{OUT} ≤ 350mA	7.6		8.4	V
Current Dissipation	I _{CC}	Tj=25°C	4.6	6.0		mA
Current Dissipation	ΔI _{CCline}	11V ≤ V _{IN} ≤ 25V, I _{OUT} =200mA		0.8		mA
Variation (Line)						
Current Dissipation	ΔI _{CCload}	5mA ≤ I _{OUT} ≤ 350mA		0.5		mA
Variation (Load)						
Output Noise Voltage	V _{NO}	10Hz ≤ f ≤ 100kHz		50		μV
Ripple Rejection	R _{rej}	f=120Hz	56			dB
		11.5V ≤ V _{IN} ≤ 22V	56	80		dB
		Tj=25°C				
Minimum Input-Output	V _{drop}	I _{OUT} =350mA	2.0			V
Voltage Drop						
Short Current	I _{OS}	Tj=25°C, V _{IN} =35V, to GND	300			mA
Peak Output Current	I _{op}	Tj=25°C	0.7			A

T-58-11-13

L78M00ML Series

[L78M09ML]

Recommended Operating Conditions at Ta=25°C

			unit
Input Voltage	V _{IN}	12 to 25	V
Output Current	I _{OUT}	5 to 500	mA

Operating Characteristics at Ta=25°C, V_{IN}=16V, I_{OUT}=350mA,

See specified Test Circuit.

			min	typ	max	unit
Output Voltage	V _{OUT}	T _j =25°C	8.6	9.0	9.4	V
Line Regulation	ΔV _{oline}	T _j =25°C, 11.5V ≤ V _{IN} ≤ 25V, I _{OUT} =200mA	6.0	100		mV
		T _j =25°C, 12V ≤ V _{IN} ≤ 20V, I _{OUT} =200mA	2.0	50		mV
Load Regulation	ΔV _{oload}	T _j =25°C, 5mA ≤ I _{OUT} ≤ 500mA			180	mV
		T _j =25°C, 5mA ≤ I _{OUT} ≤ 200mA			90	mV
Output Voltage	V _{OUT}	11.5V ≤ V _{IN} ≤ 25V, 5mA ≤ I _{OUT} ≤ 350mA	8.5		9.5	V
Current Dissipation	I _{CC}	T _j =25°C		4.6	6.0	mA
Current Dissipation Variation (Line)	ΔI _{CCline}	12.5V ≤ V _{IN} ≤ 25V, I _{OUT} =200mA			0.8	mA
		5mA ≤ I _{OUT} ≤ 350mA			0.5	mA
Current Dissipation Variation (Load)	ΔI _{CCload}	5mA ≤ I _{OUT} ≤ 350mA			0.5	mA
Output Noise Voltage	V _{NO}	10Hz ≤ f ≤ 100kHz		60		uV
Ripple Rejection	R _{rej}	f=120Hz I _{OUT} =100mA	56			dB
		12V ≤ V _{IN} ≤ 23V I _{OUT} =300mA	56	80		dB
Minimum Input-Output Voltage Drop	V _{drop}	I _{OUT} =350mA		2.0		V
Short Current	I _{OS}	T _j =25°C, V _{IN} =35V, to GND		300		mA
Peak Output Current	I _{op}	T _j =25°C		0.7		A

[L78M10ML]

Recommended Operating Conditions at Ta=25°C

			unit
Input Voltage	V _{IN}	13 to 25	V
Output Current	I _{OUT}	5 to 500	mA

Operating Characteristics at Ta=25°C, V_{IN}=17V, I_{OUT}=350mA,

See specified Test Circuit.

			min	typ	max	unit
Output Voltage	V _{OUT}	T _j =25°C	9.6	10.0	10.4	V
Line Regulation	ΔV _{oline}	T _j =25°C, 12.5V ≤ V _{IN} ≤ 25V, I _{OUT} =200mA	7.0	100		mV
		T _j =25°C, 13V ≤ V _{IN} ≤ 22V, I _{OUT} =200mA	2.0	50		mV
Load Regulation	ΔV _{oload}	T _j =25°C, 5mA ≤ I _{OUT} ≤ 500mA			200	mV
		T _j =25°C, 5mA ≤ I _{OUT} ≤ 200mA			100	mV
Output Voltage	V _{OUT}	12.5V ≤ V _{IN} ≤ 25V, 5mA ≤ I _{OUT} ≤ 350mA	9.5		10.5	V
Current Dissipation	I _{CC}	T _j =25°C		4.6	6.0	mA
Current Dissipation Variation (Line)	ΔI _{CCline}	13.5V ≤ V _{IN} ≤ 25V, I _{OUT} =200mA			0.8	mA
		5mA ≤ I _{OUT} ≤ 350mA			0.5	mA
Current Dissipation Variation (Load)	ΔI _{CCload}	5mA ≤ I _{OUT} ≤ 350mA			0.5	mA
Output Noise Voltage	V _{NO}	10Hz ≤ f ≤ 100kHz		65		uV
Ripple Rejection	R _{rej}	f=120Hz I _{OUT} =100mA	55			dB
		13V ≤ V _{IN} ≤ 25V I _{OUT} =300mA	55	80		dB
Minimum Input-Output Voltage Drop	V _{drop}	I _{OUT} =350mA		2.0		V
Short Current	I _{OS}	T _j =25°C, V _{IN} =35V, to GND		300		mA
Peak Output Current	I _{op}	T _j =25°C		0.7		A

L78M00ML Series

T-58-11-13

[L78M12ML]**Recommended Operating Conditions at Ta=25°C**

			unit
Input Voltage	V_{IN}	15 to 25	V
Output Current	I_{OUT}	5 to 500	mA

Operating Characteristics at Ta=25°C, $V_{IN}=19V$, $I_{OUT}=350mA$,

See specified Test Circuit.

			min	typ	max	unit
Output Voltage	V_{OUT}	Tj=25°C	11.5	12.0	12.5	V
Line Regulation	ΔV_{oline}	Tj=25°C, 14.5V ≤ V_{IN} ≤ 30V, $I_{OUT}=200mA$	8.0	100		mV
Load Regulation	ΔV_{oload}	Tj=25°C, 16V ≤ V_{IN} ≤ 25V, $I_{OUT}=200mA$	2.0	50		mV
		Tj=25°C, 5mA ≤ I_{OUT} ≤ 500A		240		mV
Output Voltage	V_{OUT}	Tj=25°C, 5mA ≤ I_{OUT} ≤ 200mA		120		mV
Output Voltage	V_{OUT}	14.5V ≤ V_{IN} ≤ 27V, 5mA ≤ I_{OUT} ≤ 350mA	11.4		12.6	V
Current Dissipation	I_{CC}	Tj=25°C	4.8	6.0		mA
Current Dissipation Variation (Line)	ΔI_{CCline}	15V ≤ V_{IN} ≤ 30V, $I_{OUT}=200mA$		0.8		mA
Current Dissipation Variation (Load)	ΔI_{CCload}	5mA ≤ I_{OUT} ≤ 350mA		0.5		mA
Output Noise Voltage	V_{NO}	10Hz ≤ f ≤ 100kHz		75		uV
Ripple Rejection	R_{rej}	f=120Hz	55	80		dB
		15V ≤ V_{IN} ≤ 25V $I_{OUT}=100mA$ Tj=25°C $I_{OUT}=300mA$	55	80		
Minimum Input-Output Voltage Drop	V_{drop}	$I_{OUT}=350mA$	2.0			V
Short Current	I_{OS}	Tj=25°C, $V_{IN}=35V$, to GND	300			mA
Peak Output Current	I_{op}	Tj=25°C	0.7			A

[L78M15ML]**Recommended Operating Conditions at Ta=25°C**

			unit
Input Voltage	V_{IN}	18 to 30	V
Output Current	I_{OUT}	5 to 500	mA

Operating Characteristics at Ta=25°C, $V_{IN}=23V$, $I_{OUT}=350mA$,

See specified Test Circuit.

			min	typ	max	unit
Output Voltage	V_{OUT}	Tj=25°C	14.4	15.0	15.6	V
Line Regulation	ΔV_{oline}	Tj=25°C, 17.5V ≤ V_{IN} ≤ 30V, $I_{OUT}=200mA$	10.0	100		mV
Load Regulation	ΔV_{oload}	Tj=25°C, 19V ≤ V_{IN} ≤ 30V, $I_{OUT}=200mA$	3.0	50		mV
		Tj=25°C, 5mA ≤ I_{OUT} ≤ 350mA		300		mV
Output Voltage	V_{OUT}	Tj=25°C, 5mA ≤ I_{OUT} ≤ 200mA		150		mV
Output Voltage	V_{OUT}	17.5V ≤ V_{IN} ≤ 30V, 5mA ≤ I_{OUT} ≤ 350mA	14.25		15.75	V
Current Dissipation	I_{CC}	Tj=25°C	4.8	6.0		mA
Current Dissipation Variation (Line)	ΔI_{CCline}	17.5V ≤ V_{IN} ≤ 30V, $I_{OUT}=200mA$		0.8		mA
Current Dissipation Variation (Load)	ΔI_{CCload}	5mA ≤ I_{OUT} ≤ 350mA		0.5		mA
Output Noise Voltage	V_{NO}	10Hz ≤ f ≤ 100kHz		90		uV
Ripple Rejection	R_{rej}	f=120Hz	54	70		dB
		18.5V ≤ V_{IN} ≤ 28.5V $I_{OUT}=100mA$ Tj=25°C $I_{OUT}=300mA$	54	70		
Minimum Input-Output Voltage Drop	V_{drop}	$I_{OUT}=350mA$	2.0			V
Short Current	I_{OS}	Tj=25°C, $V_{IN}=35V$, to GND	300			mA
Peak Output Current	I_{op}	Tj=25°C	0.7			A

T-58-11-13

L78M00ML Series

[L78M18ML]**Recommended Operating Conditions at Ta=25°C**

			unit
Input Voltage	V_{IN}	21 to 33	V
Output Current	I_{OUT}	5 to 500	mA

**Operating Characteristics at Ta=25°C, $V_{IN}=27V$, $I_{OUT}=350mA$,
See specified Test Circuit.**

			min	typ	max	unit
Output Voltage	V_{OUT}	$T_j=25^\circ C$	17.3	18.0	18.7	V
Line Regulation	ΔV_{oline}	$T_j=25^\circ C, 21V \leq V_{IN} \leq 35V, I_{OUT}=200mA$	10.0	100		mV
		$T_j=25^\circ C, 22V \leq V_{IN} \leq 35V, I_{OUT}=200mA$	5.0	50		mV
Load Regulation	ΔV_{oload}	$T_j=25^\circ C, 5mA \leq I_{OUT} \leq 500mA$			360	mV
		$T_j=25^\circ C, 5mA \leq I_{OUT} \leq 200mA$			180	mV
Output Voltage	V_{OUT}	$21V \leq V_{IN} \leq 33V, 5mA \leq I_{OUT} \leq 350mA$	17.1		18.9	V
Current Dissipation	I_{CC}	$T_j=25^\circ C$	4.9		6.0	mA
Current Dissipation	ΔI_{CCline}	$21V \leq V_{IN} \leq 33V, I_{OUT}=200mA$			0.8	mA
Variation (Line)						
Current Dissipation	ΔI_{CCload}	$5mA \leq I_{OUT} \leq 350mA$			0.5	mA
Variation (Load)						
Output Noise Voltage	V_{NO}	$10Hz \leq f \leq 100kHz$		100		μV
Ripple Rejection	R_{rej}	$f=120Hz$	53			dB
		$22V \leq V_{IN} \leq 33V$ $T_j=25^\circ C$	53	70		dB
		$I_{OUT}=100mA$ $I_{OUT}=300mA$				
Minimum Input-Output	V_{drop}	$I_{OUT}=350mA$	2.0			V
Voltage Drop						
Short Current	I_{OS}	$T_j=25^\circ C, V_{IN}=35V, to GND$	300			mA
Peak Output Current	I_{op}	$T_j=25^\circ C$	0.7			A

[L78M20ML]**Recommended Operating Conditions at Ta=25°C**

			unit
Input Voltage	V_{IN}	23 to 35	V
Output Current	I_{OUT}	5 to 500	mA

**Operating Characteristics at Ta=25°C, $V_{IN}=29V$, $I_{OUT}=350mA$,
See specified Test Circuit.**

			min	typ	max	unit
Output Voltage	V_{OUT}	$T_j=25^\circ C$	19.2	20.0	20.8	V
Line Regulation	ΔV_{oline}	$T_j=25^\circ C, 23V \leq V_{IN} \leq 35V, I_{OUT}=200mA$	10.0	100		mV
		$T_j=25^\circ C, 24V \leq V_{IN} \leq 35V, I_{OUT}=200mA$	5.0	50		mV
Load Regulation	ΔV_{oload}	$T_j=25^\circ C, 5mA \leq I_{OUT} \leq 500mA$			400	mV
		$T_j=25^\circ C, 5mA \leq I_{OUT} \leq 200mA$			200	mV
Output Voltage	V_{OUT}	$23V \leq V_{IN} \leq 35V, 5mA \leq I_{OUT} \leq 350mA$	19.0		21.0	V
Current Dissipation	I_{CC}	$T_j=25^\circ C$	4.9		6.0	mA
Current Dissipation	ΔI_{CCline}	$23V \leq V_{IN} \leq 35V, I_{OUT}=200mA$			0.8	mA
Variation (Line)						
Current Dissipation	ΔI_{CCload}	$5mA \leq I_{OUT} \leq 350mA$			0.5	mA
Variation (Load)						
Output Noise Voltage	V_{NO}	$10Hz \leq f \leq 100kHz$		110		μV
Ripple Rejection	R_{rej}	$f=120Hz$	53			dB
		$24V \leq V_{IN} \leq 34V$ $T_j=25^\circ C$	53	70		dB
		$I_{OUT}=100mA$ $I_{OUT}=300mA$				
Minimum Input-Output	V_{drop}	$I_{OUT}=350mA$	2.0			V
Voltage Drop						
Short Current	I_{OS}	$T_j=25^\circ C, V_{IN}=35V, to GND$	300			mA
Peak Output Current	I_{op}	$T_j=25^\circ C$	0.7			A

L78M00ML Series

T-58-11-13

[L78M24ML]

Recommended Operating Conditions at Ta=25°C

			unit
Input Voltage	V _{IN}	27 to 35	V
Output Current	I _{OUT}	5 to 500	mA

Operating Characteristics at Ta=25°C, V_{IN}=33V, I_{OUT}=350mA, See specified Test Circuit.

			min	typ	max	unit
Output Voltage	V _{OUT}	T _j =25°C	23.0	24.0	25.0	V
Line Regulation	ΔV _{oline}	T _j =25°C, 27V ≤ V _{IN} ≤ 35V, I _{OUT} =200mA	10.0	100		mV
		T _j =25°C, 28V ≤ V _{IN} ≤ 35V, I _{OUT} =200mA	5.0	50		mV
Load Regulation	ΔV _{oload}	T _j =25°C, 5mA ≤ I _{OUT} ≤ 500mA			480	mV
		T _j =25°C, 5mA ≤ I _{OUT} ≤ 200mA			240	mV
Output Voltage	V _{OUT}	27V ≤ V _{IN} ≤ 35V, 5mA ≤ I _{OUT} ≤ 350mA	22.8		25.2	V
Current Dissipation	I _{CC}	T _j =25°C	5.0	6.0		mA
Current Dissipation	ΔI _{CCline}	27V ≤ V _{IN} ≤ 35V, I _{OUT} =200mA		0.8		mA
Current Dissipation	ΔI _{CCload}	5mA ≤ I _{OUT} ≤ 350mA		0.5		mA
Current Dissipation	ΔI _{CCload}	5mA ≤ I _{OUT} ≤ 350mA		0.5		mA
Output Noise Voltage	V _{NO}	10Hz ≤ f ≤ 100kHz		170		uV
Ripple Rejection	R _{rej}	f=120Hz	50			dB
		28V ≤ V _{IN} ≤ 35V, I _{OUT} =100mA	50	70		dB
		T _j =25°C, I _{OUT} =300mA				
Minimum Input-Output	V _{drop}	I _{OUT} =350mA		2.0		V
Voltage Drop						
Short Current	I _{OS}	T _j =25°C, V _{IN} =35V, to GND		300		mA
Peak Output Current	I _{op}	T _j =25°C		0.7		A

Test Circuit (Common to L78M00ML Series)

