

ISO INTERFACE

- WIDE OPERATING POWER SUPPLY VOLTAGE RANGE 4.5V VS 45V
- REVERSE SUPPLY (BATTERY) PROTECTED DOWN TO VS -24V
- LOW QUIESCENT CURRENT IN OFF CONDITION $I_{Q\text{TYP}} = 100\mu\text{A}$
- TTL COMPATIBLE TX INPUT
- BIDIRECTIONAL K-I/O PIN WITH SUPPLY VOLTAGE DEPENDENT INPUT THRESHOLD
- OVERTEMPERATURE SHUT DOWN FUNCTION SELECTIVE TO K-I/O PIN
- HIGH SIGNAL VOLTAGE RANGE -24V VK +45V
- OUTPUT CURRENT LIMITATION $I_K = 60\text{MA}$
- DEFINED OFF OUTPUT STATUS IN UNDERVOLTAGE OR VS OR GND LACK CONDITION
- CONTROLLED OUTPUT SLOPE FOR LOW EMI
- HIGH INPUT IMPEDANCE DURING VS OR GND LACK
- DEFINED OUTPUT ON STATUS OF LO OR RX DURING INPUT SIGNAL LACK AT LI OR K
- DEFINED K OUTPUT OFF DURING TX INPUT SIGNAL LACK

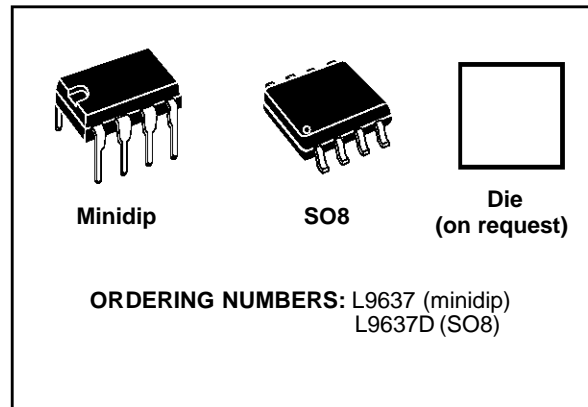

- SEPARATE L COMPARATOR WITH K - I EQUAL FUNCTIONALITY
- INTEGRATED PULL UP RESISTANCES
- EMV ROBUSTNESS OPTIMIZED
- ESD: ALL PINS ARE GUARANTED TILL 600V

DESCRIPTION

The L9637 is a monolithic integrated circuit containing the whole standard ISO 9141 compatible interface functions.

BLOCK DIAGRAM

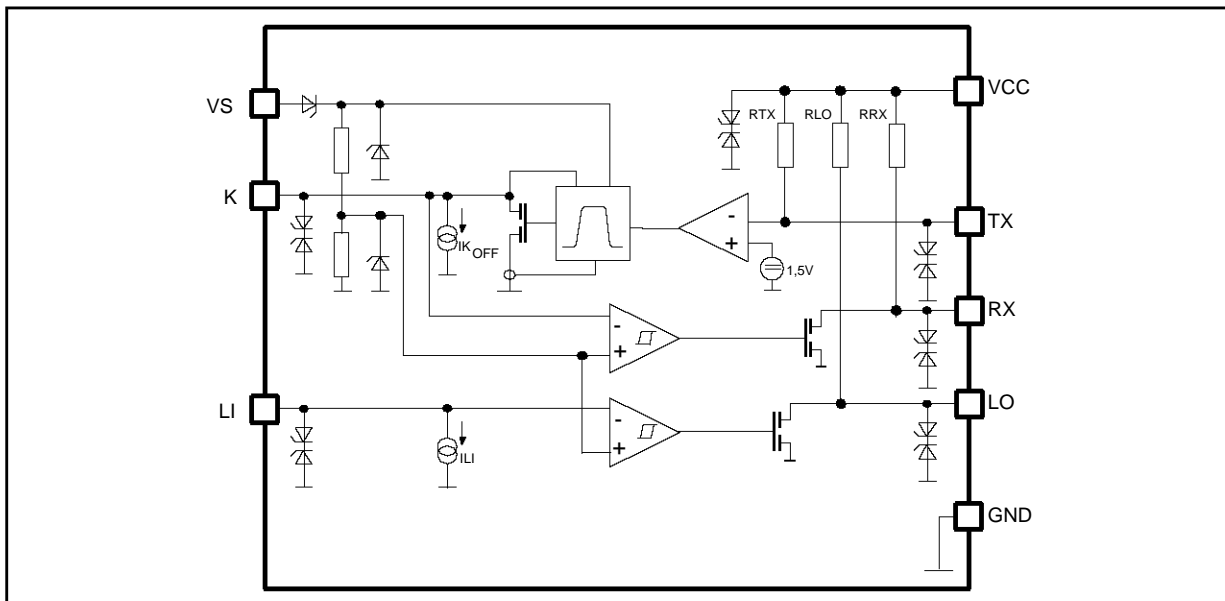

ABSOLUTE MAXIMUM RATINGS (No damage or latch)

Symbol	Parameter	Value	Unit
V _S	Supply Voltage	-24 to +45	V
V _{CC}	Stabilized Voltage	-0.3 to +10	V
V _{IN}	Input Voltage @ LI Input Voltage @ TX	-24 to +45 -24 to +10	V V
V _{out}	Output Voltage @ K, RX, LO	-24 to +45	V
i _{PIN}	Transient pin current t < 2ms to survive interference "Schaffner" pulses in connection with suitable external series resistance	-30 to +30	mA

PIN CONNECTION (Top view)

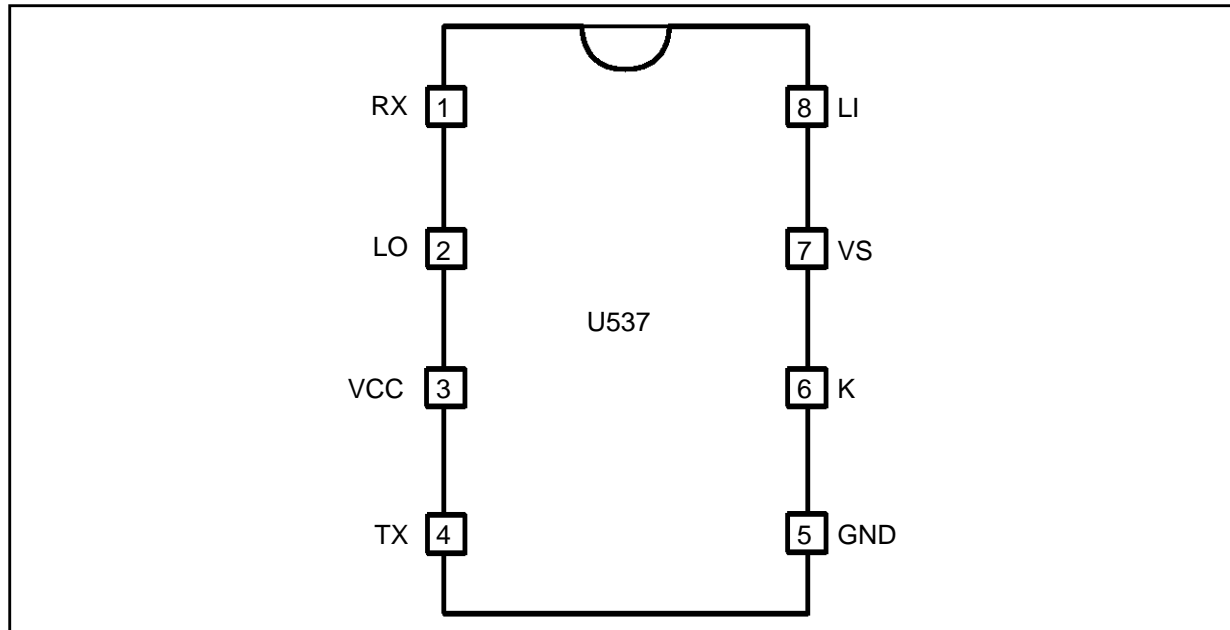

THERMAL DATA

Symbol	Parameter	Min.	Typ.	Max.	Unit
T _{jMonitor}	Temperature K switch off	160	175	190	°C
	Temperature K switch on	140	155	170	°C
R _{th j-amb} (*)	Thermal steady state junction to ambient resistance for SO8	130	155	180	°C/W
	Thermal steady state junction to ambient resistance for Minidip	80	100	120	°C/W

(*) Referring to "Thermal Management in Surface Mount Technology" ST-databook

PIN DESCRIPTION

N.	Name	Function
1	RX	Output for K as input
2	LO	Output L comparator
3	VCC	Stabilized voltage supply
4	TX	Input for K as output
5	GND	Common GND
6	K	Bidirectional I/O
7	VS	Supply voltage
8	LI	Input L comparator

OPERATING RANGE (The electrical characteristics are valid within the below defined operating range, unless otherwise specified).

Symbol	Parameter	Test Condition	Min.	Typ.	Max.	Unit
V _S	Supply Voltage		4.5	12	36	V
V _{CC}	Stabilized Voltage		2	5	10	V
T _j	Junction temperature		-40		85 *)	°C

*) Functionally will be guaranteed by design until T_{JMon OFF}

ELECTRICAL CHARACTERISTIC

Symbol	Parameter	Test Condition	Min.	Typ.	Max.	Unit
VK _{low}	Input Voltage Low state	RX output status LOW 4.5V ≤ V _S ≤ 20V	-24		0.45V _S	V
		RX output status LOW 20V ≤ V _S	-24		8	V
VK _{high}	Input Voltage High state	RX output status HIGH 4.5V ≤ V _S ≤ 20V	0.55V _S		45	V
		RX output status HIGH 20V ≤ V _S	12		45	V
VK _{hys}	Input Threshold Hysteresis			0.025 V _S	0.8	V
IK _{off}	Input Current	V _{TX} ≥ V _{TXhigh} 2 < VK ≤ 45V -24V ≤ VK ≤ 2V	1 -5	2	10 25	μA μA
RK _{ON}	Output ON Impedance	V _{TX} ≤ V _{TXlow} @ V _S > 6.5V @ V _S ≥ 4.5V		10 45	30 90	Ω Ω
IK _{SC}	Short Circuit Current		30	60	100	mA
V _{TXlow}	Input voltage LOW state		-24		1	V
V _{TXhigh}	Input voltage HIGH state		2		10	V
		@ V _S > 16V	2.5		10	V
RR _{XO} RLO _O	Output ON Impedance	VK ≤ VK _{low} ; VLI ≤ VLI _{low} @ V _S > 6.5V @ V _S ≥ 4.5V		40 180	90 360	Ω Ω
IR _{XSC} ILO _{SC}	Output Short Circuit Current		9	20	30	mA
VR _{XH} VLO _H	Output Voltage HIGH state	10MΩ ≤ R _{LRX} 10MΩ ≤ R _{LRX}	V _{CC} - 0.25	V _{CC} - 0.1	V _{CC}	V
RLO RRX	Output pull-up resistance	Output status = (HIGH) -0.15V ≤ VLO ≤ V _{CC} + 0.15V -0.15V ≤ VRX ≤ V _{CC} + 0.15V	6	10	18	KΩ
RTX	Input pull up resistance	-0.15V ≤ V _{TX} ≤ V _{CC} + 0.15V	12	20	36	KΩ
VLI _{low}	Input voltage LOW state	LO output status LOW 4.5V ≤ V _S ≤ 20V	-24		0.45V _S	V
		LO output status LOW 20V ≤ V _S	-24		8	V
VLI _{high}	Input voltage HIGH state	LO output status HIGH 4.5V ≤ V _S ≤ 20V	0.55V _S		45	V
		LO output status HIGH 20V ≤ V _S	12		45	V
VLI _{hys}	Input threshold hysteresis			0.025V _S	0.8	V
ILI	Input current	2V < VLI ≤ 45V	1	2	10	mA
		-24V ≤ VLI ≤ 2V	-5	2	10	μA

ELECTRICAL CHARACTERISTIC (continued)

Symbol	Parameter	Test Condition	Min.	Typ.	Max.	Unit
$C_{ki, LO, RX}$	Internal output capacities				20	pF
f_{LI-LO} f_{K-RX} f_{TX-K}	Transmission Frequency	$9V < V_S < 16V$ (external loads) $R_{KO} = 510\Omega, C_K \leq 1.3nF$	50	100		kHz
t_{rLI-LO} t_{rK-RX} t_{rTX-K}	Rise Time	for the definition of t_1, t_2 see fig.1.		2	6	μs
t_{fLI-LO} t_{fK-RX} t_{fTX-K}	Fall Time	$9V < V_S < 16V$ (external loads) $R_{KO} = 510\Omega, C_K \leq 1.3nF$		2	6	μs
$t_{OFF, LI-LO}$ $t_{OFF, K-RX}$ $t_{OFF, TX-K}$	Switch OFF time	for the definition of t_{on}, t_{OFF} see fig.1.		4	17	μs
$t_{ON, LI-LO}$ $t_{ON, K-RX}$ $t_{ON, TX-K}$	Switch ON time	$9V < V_S < 16V$ (external loads) $R_{KO} = 510\Omega, C_K \leq 1.3nF$		4	2.3	μs
I_{CC}	Supply Current	$V_{CC} \leq 5.5V, V_{TX} = 0V$ $V_{LI} \geq V_{LI_{high}}$ $V_{TX} \geq V_{TX_{high}}$ @ $V_{CC} \leq 5.5V, T_j \leq 85^\circ C$	-5	<1	5	μA
I_S	Supply current	$V_S \leq 16V, V_{LI}, V_{TX} = 0V$ $V_{LI} \geq V_{LI_{high}}$ $V_{TX} \geq V_{TX_{high}}$ @ $V_S \leq 12V, T_j \leq 85^\circ C$		1.2	2	μA

Figure 1.

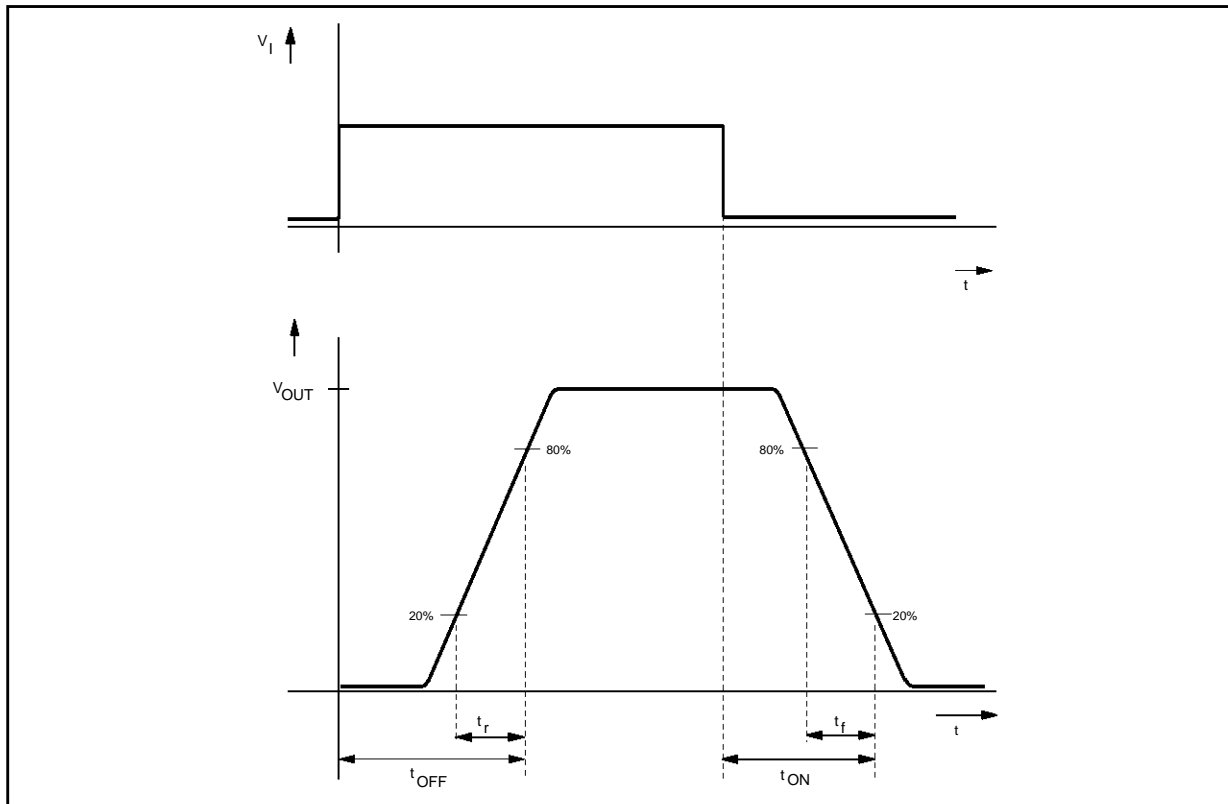
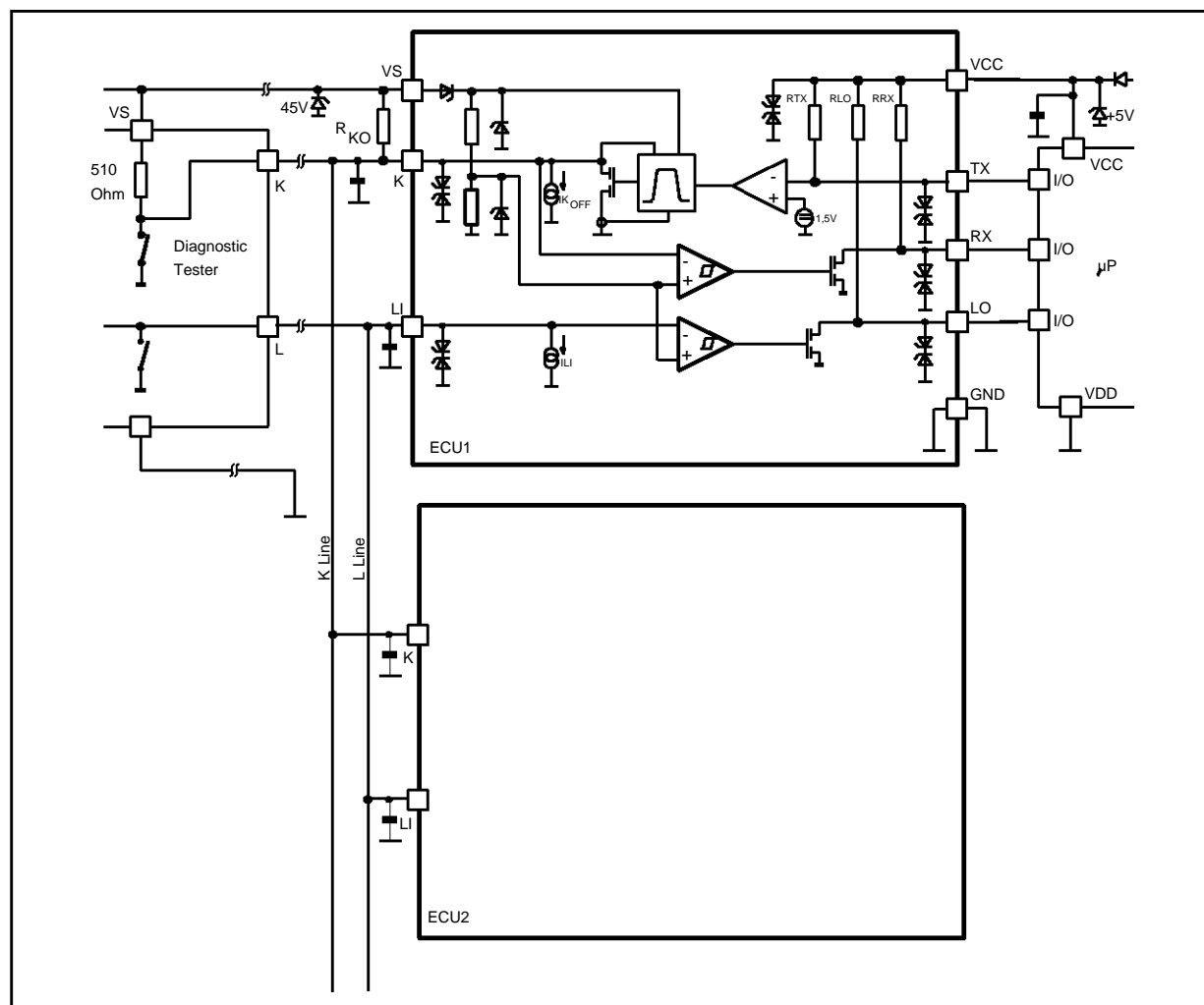

Figure 2: ISO Application Circuit



FUNCTIONAL DESCRIPTION

The L9637 is a monolithic bus driver designed to provide bidirectional serial communication in automotive diagnostic applications according to the specification "Diagnostic Systems ISO9141".

The device provides a bidirectional link, called K, to the V_{Bat} related diagnosis bus. It also includes a separate comparator L which is also able to be linked to the V_{Bat} bus. The input TX and output RX of K are related to V_{CC} with her integrated pull up resistances. Also the L comparator output LO has a pull up resistance connected to V_{CC} .

The maximum external pull up resistance at K related to V_S should not be higher than $R_{K0} \leq 5K\Omega$ to achieve clear output conditions.

All V_{Bat} bus defined inputs LI and K have supply voltage dependent thresholds together with sufficient hysteresis to suppress line spikes. These pins are protected against overvoltages, shorts to GND and V_S and can also be driven beyond V_S

and GND. These features are also given for TX, RX and LI only taking into account the behaviour of the internal pull up resistances. The thermal shut down function switches OFF the K output if the chip temperature increases above the thermal shut down threshold. To achieve no fault for V_S undervoltage conditions the outputs will be switched OFF and stay at high impedance. The device is also protected against reverse battery condition. During lack of V_S or GND all pins shows high impedance characteristic. To realize a lack of the V_S related bus line LI and K the outputs LO and RX shows defined ON status. Suppressing all 4 classes of "Schaffner" signals all pins can be load with short current pulses $t \leq 2ms$ of max. $\pm 30mA$. All these features together with a high possible baud rate $>100Kbaud$, controlled output slopes for low EMI, a wide power supply voltage range and a very small quiescent current during OFF condition $I_q \leq 80\mu A$ make this device high efficient for ISO diagnosis bus systems.

SO8 PACKAGE MECHANICAL DATA

DIM.	mm			inch		
	MIN.	TYP.	MAX.	MIN.	TYP.	MAX.
A			1.75			0.069
a1	0.1		0.25	0.004		0.010
a2			1.65			0.065
a3	0.65		0.85	0.026		0.033
b	0.35		0.48	0.014		0.019
b1	0.19		0.25	0.007		0.010
C	0.25		0.5	0.010		0.020
c1	45° (typ.)					
D	4.8		5.0	0.189		0.197
E	5.8		6.2	0.228		0.244
e		1.27			0.050	
e3		3.81			0.150	
F	3.8		4.0	0.15		0.157
L	0.4		1.27	0.016		0.050
M			0.6			0.024
S	8° (max.)					

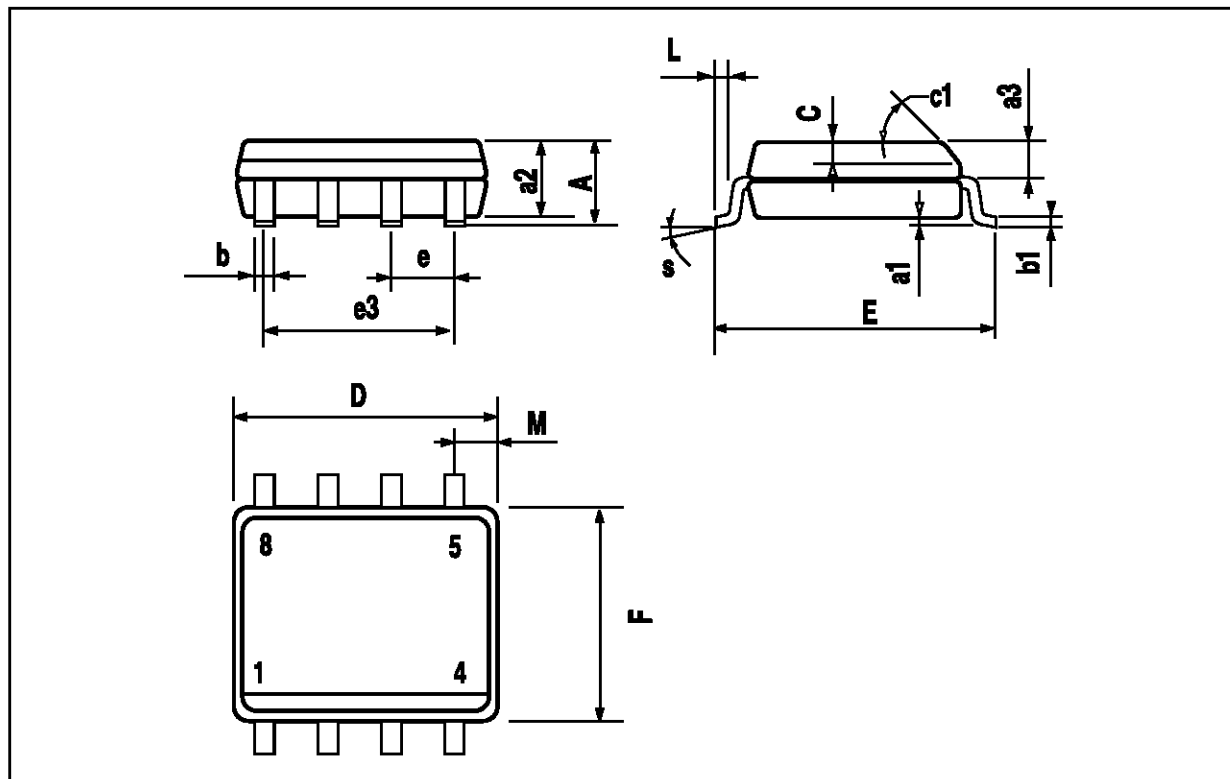

MINIDIP PACKAGE MECHANICAL DATA

DIM.	mm			inch		
	MIN.	TYP.	MAX.	MIN.	TYP.	MAX.
A		3.32			0.131	
a1	0.51			0.020		
B	1.15		1.65	0.045		0.065
b	0.356		0.55	0.014		0.022
b1	0.204		0.304	0.008		0.012
D			10.92			0.430
E	7.95		9.75	0.313		0.384
e		2.54			0.100	
e3		7.62			0.300	
e4		7.62			0.300	
F			6.6			0.260
I			5.08			0.200
L	3.18		3.81	0.125		0.150
Z			1.52			0.060

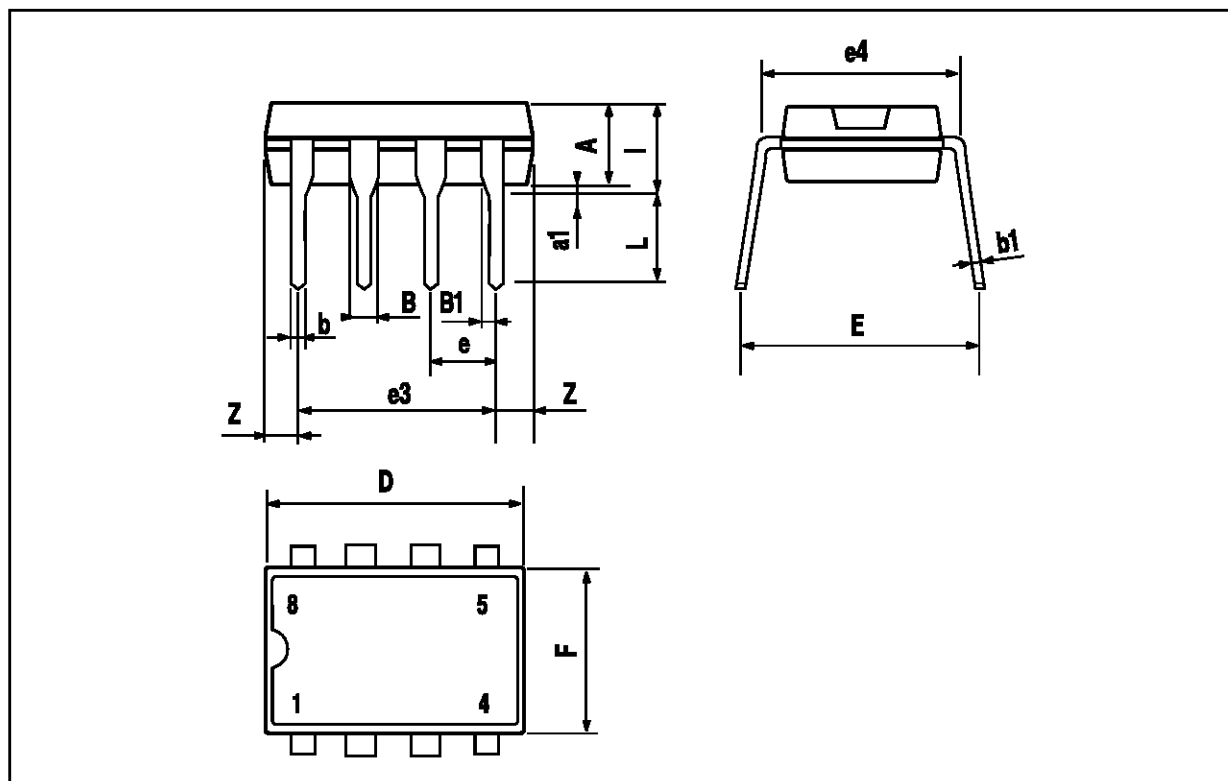

Information furnished is believed to be accurate and reliable. However, SGS-THOMSON Microelectronics assumes no responsibility for the consequences of use of such information nor for any infringement of patents or other rights of third parties which may result from its use. No license is granted by implication or otherwise under any patent or patent rights of SGS-THOMSON Microelectronics. Specifications mentioned in this publication are subject to change without notice. This publication supersedes and replaces all information previously supplied. SGS-THOMSON Microelectronics products are not authorized for use as critical components in life support devices or systems without express written approval of SGS-THOMSON Microelectronics.

© 1994 SGS-THOMSON Microelectronics - All Rights Reserved

SGS-THOMSON Microelectronics GROUP OF COMPANIES

Australia - Brazil - France - Germany - Hong Kong - Italy - Japan - Korea - Malaysia - Malta - Morocco - The Netherlands - Singapore - Spain - Sweden - Switzerland - Taiwan - Thailand - United Kingdom - U.S.A.