

OCTAL SUPPLY CONTACT MONITORING CIRCUIT

- OPERATING DC SUPPLY VOLTAGE RANGE 5V TO 25V
- SUPPLY OVERVOLTAGE PULSE UP TO 40V
- VERY LOW STANDBY QUIESCENT CURRENT 0.2mA
- INTERNAL CLAMPING DIODES AT CONTACT INPUTS TO V_S AND GND
- INPUT PULSE CURRENT CAPABILITY UP TO + 50mA, - 75mA
- NOMINAL CONTACT CURRENTS OF 10mA DEFINED BY EXTERNAL CONTACT SERIES RESISTORS R_{IN1-8}
- CONTACT STATUS MONITORING BY COMPARING THE RESISTANCE AT CONTACT SENSE INPUTS WITH THE INTERNAL REFERENCE RESISTOR VALUE
- HIGH IMMUNITY DUE TO RESISTANCE COMPARISON WITH HYSTERESIS

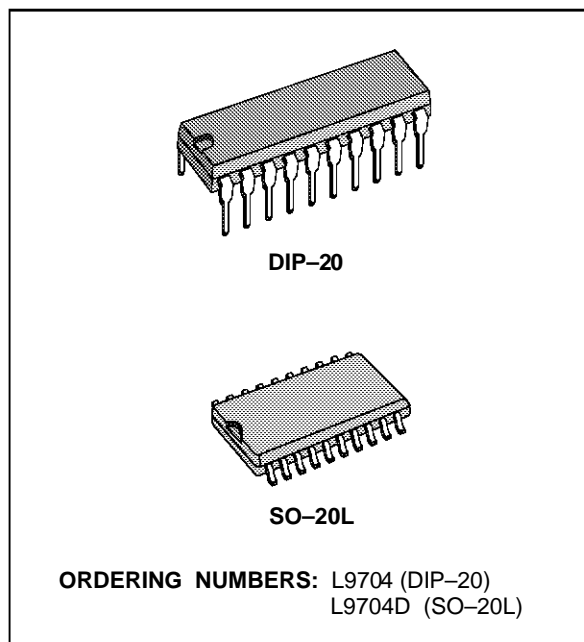

DESCRIPTION

The L9704 is a bipolar monolithic integrated circuit for monitoring the status of up to eight contacts connected to the power supply (battery).

It contains eight contact sense inputs and eight microcomputer compatible three-state outputs.

BLOCK DIAGRAM

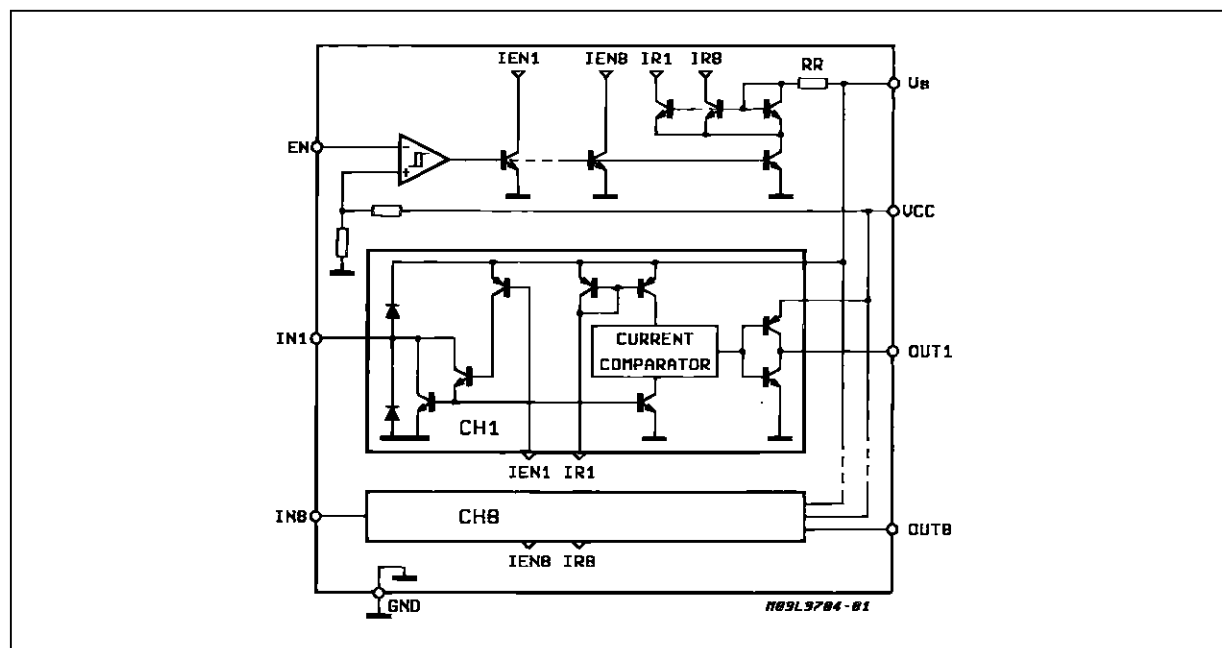

L9704

ABSOLUTE MAXIMUM RATINGS

Symbol	Parameter	Test Conditions	Unit
V _S	Transient Supply Voltage (t ≤ 1s)	+40	V
V _{CC}	Logic Supply Voltage	7	V
I _{IN DC}	Input DC Current	±40	mA
I _{INP}	Input DC Pulse (test pulse specification: 0 < t _P < 2ms, f ≤ 0.2Hz, n = 25000)	50 -75	mA mA
I _O	Output Current	Internally Limited	
V _{EN}	Enable Input Voltage	V _{CC} +0.3 -0.3	V V
P _O	Power Dissipation at T _{amb} = 80°C DIP20 SO20	875 420	mW mW
T _{stg,TJ}	Storage and Junction Temperature Range	-55 to 150	°C

THERMAL DATA

Symbol	Parameter	DIP20	SO20	Unit
R _{th j-amb}	Thermal Resistance Junction to Ambient MAX.	80	165	°C/W

PIN CONNECTION (top view)

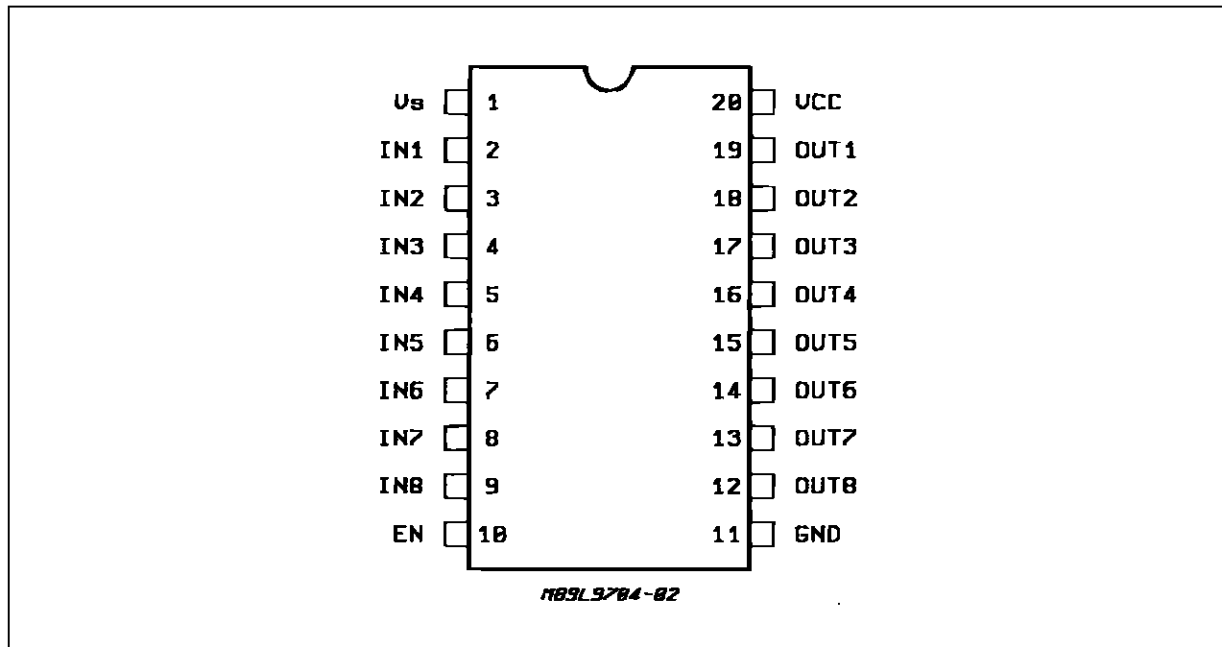

ELECTRICAL CHARACTERISTICS ($5V \leq V_S \leq 25V$; $-40^\circ\text{C} \leq T_j \leq 125^\circ\text{C}$; $4.75V \leq V_{CC} \leq 5.25V$ unless otherwise specified; the currents flowing in the arrow direction are assumed positive as marked in the application circuit diagram, fig. 1).

Symbol	Parameter	Test Conditions	Min.	Typ.	Max.	Unit			
V_{ENL}	Enable Input Voltage LOW (device activated)				0.8	V			
V_{ENH}	Enable Input Voltage HIGH		2.4			V			
V_{ENhyst}	Enable Input Hysteresis		200	300	800	mV			
I_{EN}	Enable Input Current	$2.4V < V_{EN} < V_{CC}$			5	μA			
		$0V < V_{EN} < 0.8V$	-5	-1		μA			
V_{OUTH}	Output Voltage HIGH	$0 < I_{OUT} < 100\mu\text{A}$	4.0	$V_{CC} - 0.1$	V_{CC}	V			
V_{OUTL}	Output Voltage LOW	$I_{OUT} = -1\text{mA}$	0.05	0.2	0.4	V			
I_{OUTTS}	Output TRISTATE Current	$0 < V_{OUT} < V_{CC}$			0.5	μA			
V_{IN}	Input Voltage (device active)	EN = LOW $R_{IN} = 1\text{k}\Omega$	0.4	1.5	2	V			
V_{IN}	Input Voltage During Clamping (device disabled)	EN = HIGH $I_{IN} = 30\text{mA}$ $I_{IN} = -30\text{mA}$	$V_S + 0.3$ -2	$V_S + 1$ -1	$V_S + 2$ -0.3	V V			
I_{OUT}	Output Current	OUT = HIGH $V_{OUT} = 0$			2	mA			
I_{OUT}	Output Current	OUT = LOW $V_{OUT} = 5.5V$			-20	mA			
R_{IL}	Input Resistor (note 1) LOW Threshold	$5V < V_S < 16V$ $ \Delta V_{GND} \leq 0.1V_S$	1.1	4.8		$\text{K}\Omega$			
R_{IH}	Input Resistor (note 1) HIGH Threshold						6.5	29	$\text{K}\Omega$
$\frac{R_{IL}}{R_{IH}}$	Input Resistor Threshold Ratio (note1)						0.65	0.75	0.85
I_{QC}	Quiescent Current	EN = HIGH ($t_{ENH} \geq 80\mu\text{s}$) $5V < V_S < 16V$ $-40^\circ\text{C} \leq T_j \leq 100^\circ\text{C}$ All Inputs Open		0.12	0.16	mA			
I_{QS}							0.04	mA	
S_{IIN2}	Input Leakage Current	All Inputs Closed $V_{BAT} \leq V_{D1}$			0.24	mA			
I_{QC} I_{QS}	Quiescent Current	EN = LOW			13	mA			
					2	mA			
t_{do}	Delay Time/Output (EN LOW to output data ready)	$C_{OUT} \leq 50\text{pF}$			15 $+3R_{IN}C_{IN}$	μs			
t_{dTS}	Delay Time/Tristate (EN HIGH to output TRISTATE)	$C_{OUT} \leq 50\text{pF}$			10	μs			

Notes :

1. The input resistor threshold value is a resistor value from the IN-pin to battery at which the corresponding output changes its status (see fig. 3)

2: S_{IIN} is the sum of the input currents $S_{IIN} = \sum_{i=1}^8 I_{INi}$.

APPLICATION CIRCUIT DIAGRAM

Figure 1 : Typical application diagram for the L9704 circuit. The current flowing in the arrow direction is assumed positive. The external capacitors C_{IN} and C_{OUT} represent the total wiring capacitance at the corresponding pins.

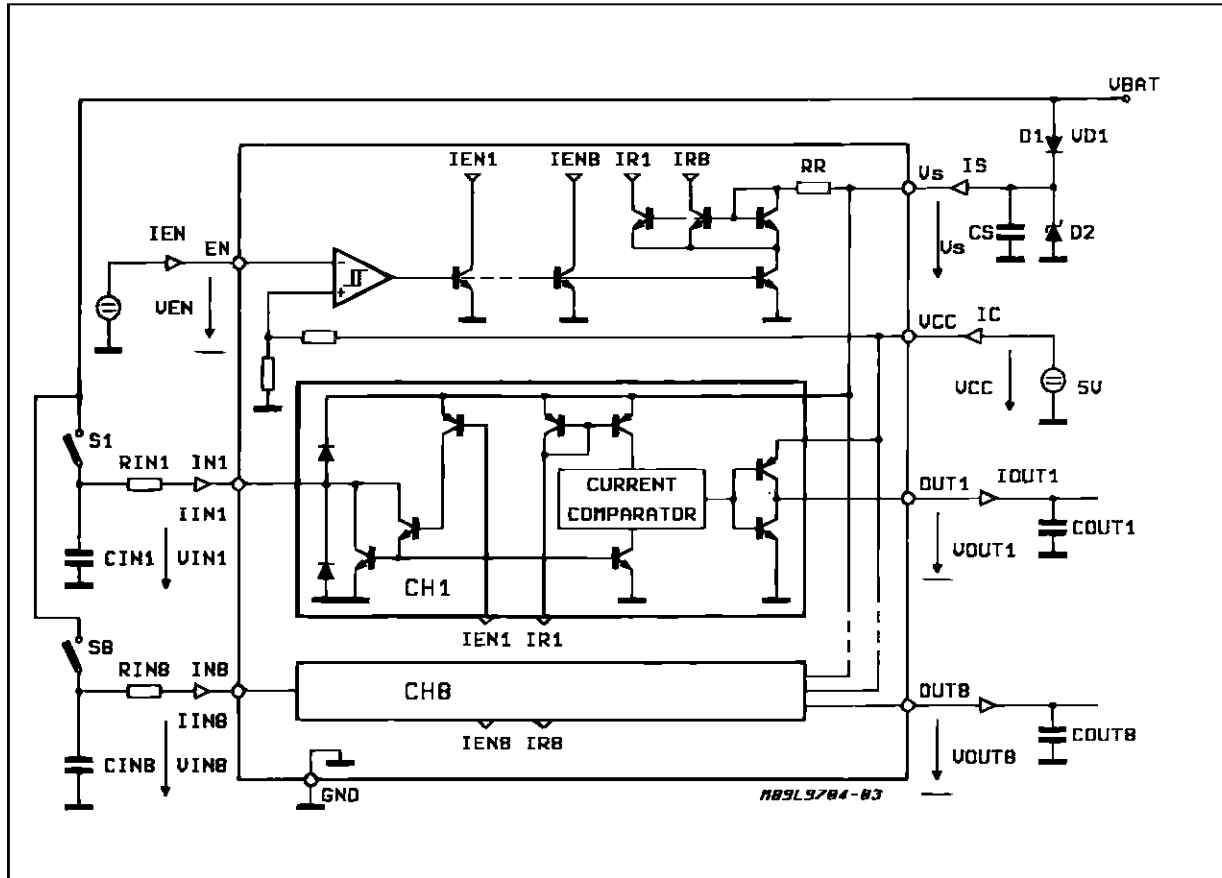

FUNCTIONAL DESCRIPTION

The L9704 circuit monitors the status of the contacts connected to battery and through the series external resistors R_{IN} to the contact sense input pins. The contacts equivalent circuit is supposed to be as shown in fig. 2.

The L9704 circuit compares the input current with the current through the internal reference resistor. The device is designed to work with an external input series resistor of R_{IN1-8} = 1kΩ. With this input resistor the contact current, when the contact is closed and the device activated (EN = LOW) is

$$I_{IN} = \frac{V_{BAT} + \Delta V_{BAT} - 2V}{1K\Omega} \quad (1)$$

For this calculation the limit value of the V_{IN} (saturation voltage of 2V) was considered so that the lowest limit value of I_{IN} is calculated in (1).

The function of the circuit can be demonstrated with the transfer characteristics, showing the output

status as a function of the input resistor R_I, shown in figure 3. The input resistor is a sum of the R_{IN} and the contact resistance R_{CON} or R_{COFF}, for the closed contact :

$$R_I = R_{IN} + R_{CON}, \quad (2)$$

and for the open contact :

$$R_I = R_{IN} + R_{COFF}. \quad (3)$$

The output goes HIGH when the input resistance increases above 6.5kΩ (typical value) and goes LOW, when the input resistance decreases below 4.8kΩ (typical value). The limit values of R_I = 1.1kΩ for LOW and R_I = 29kΩ for HIGH implies that a contact with R_{CON} = 100Ω (at I_{IN} = 10mA) will be recognized as ON = LOW and a contact with R_{COFF} = 28kΩ will be recognized as OFF = HIGH. These limits are valid within the supply voltage range 5V ≤ V_S ≤ 16V, the battery voltage potential difference of |ΔV_{BAT}| ≤ 0.1V_{BAT} and the variation of the reverse battery protection diode D1 voltage from 0.5V to 1V.

The internal clamping diodes at the contact monitoring inputs, together with the external contact series resistors R_{IN} , allows the device to withstand transients at the contact connection. The contact series resistor R_{IN} limits the input current at the transient.

The dynamic behaviour of the circuit is defined by the times t_{do} and t_{dTS} . When the contact becomes open, the input capacitor C_{IN} must be charged

through the resistor R_{IN} . In this case the total delay time may also be influenced by the time constant $R_{IN} C_{IN}$. The delay time t_{dTS} , when disabling the device is defined only by the internal circuitry. In both cases, an external output capacitance less than 50pF is assumed, the internal output capacitances of the three-state buffers are less than 5pF.

Figure 2 : The Contact Sense Input Connection with the Contact Equivalent Circuit.

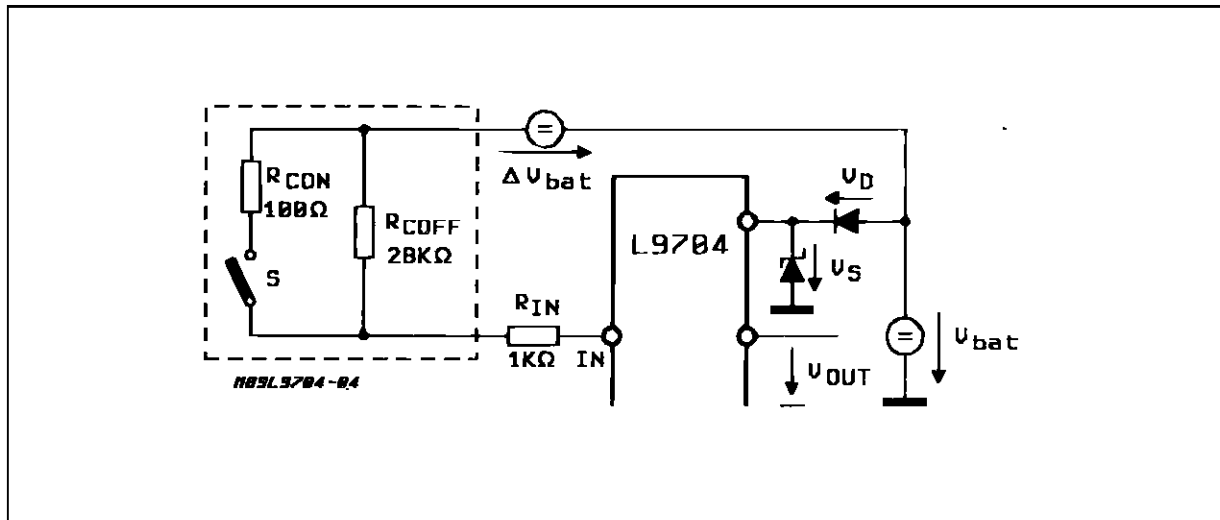
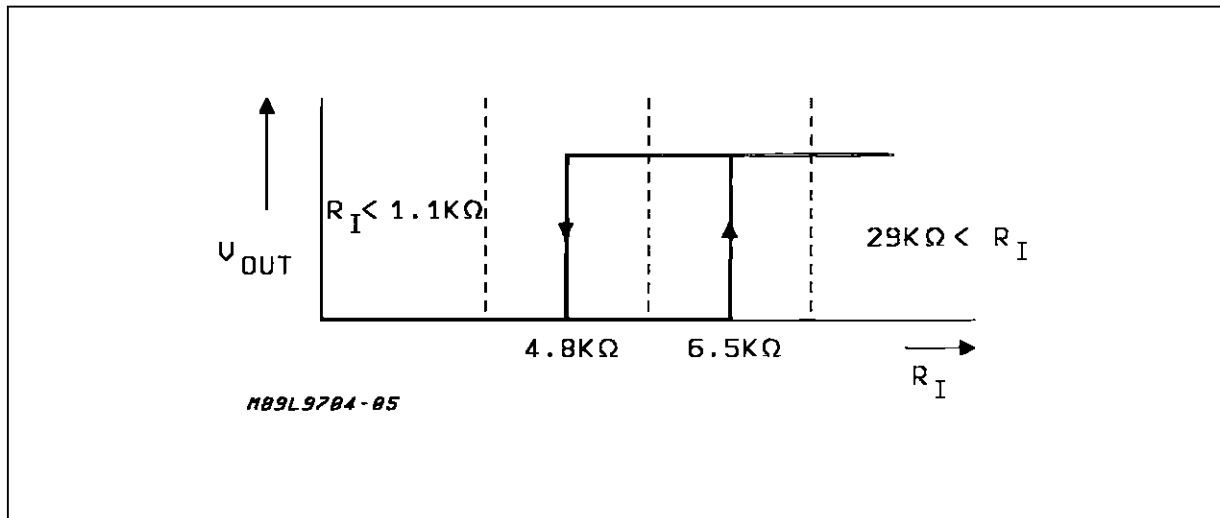
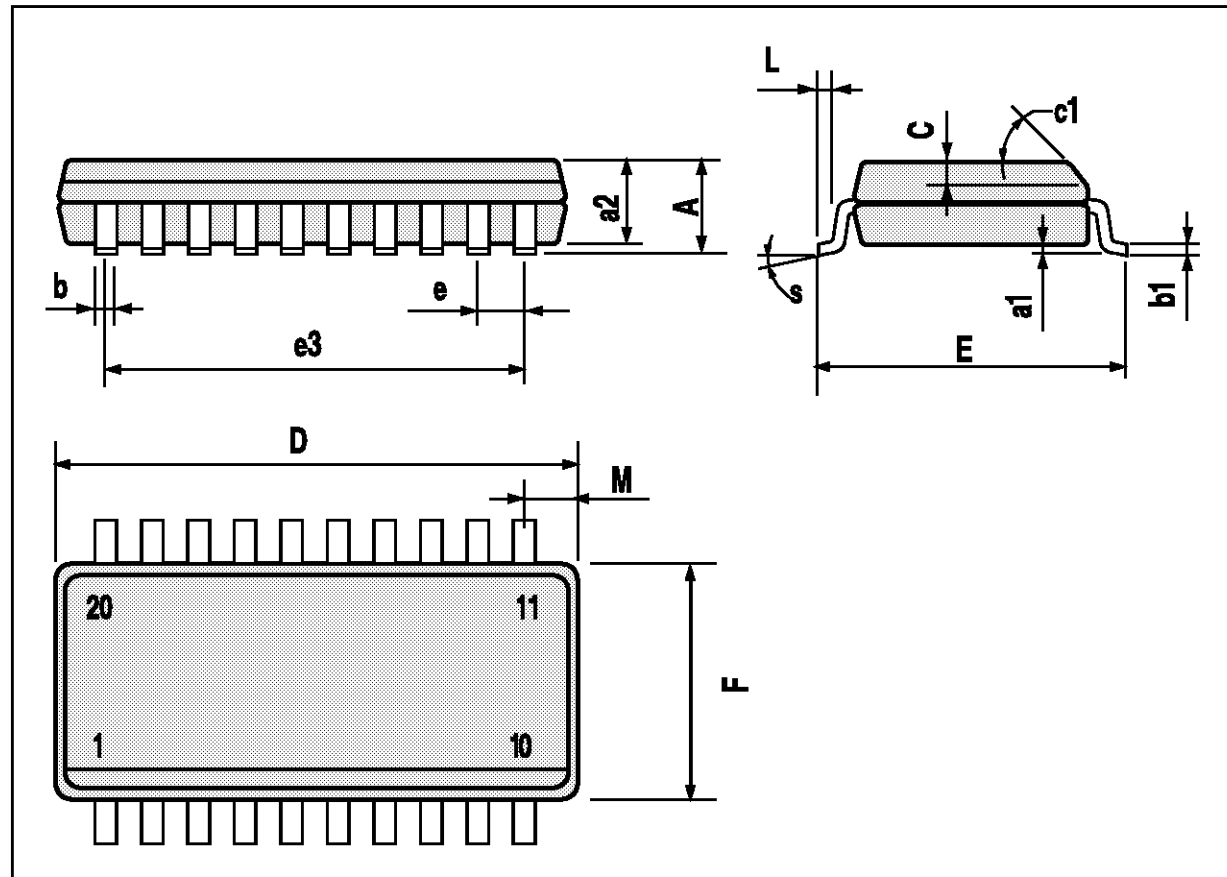

Figure 3 : The Output Voltage as a Function of the Input Resistance at the Corresponding Contact Sense Input.



SO20 PACKAGE MECHANICAL DATA

DIM.	mm			inch		
	MIN.	TYP.	MAX.	MIN.	TYP.	MAX.
A			2.65			0.104
a1	0.1		0.3	0.004		0.012
a2			2.45			0.096
b	0.35		0.49	0.014		0.019
b1	0.23		0.32	0.009		0.013
C		0.5			0.020	
c1	45 (typ.)					
D	12.6		13.0	0.496		0.512
E	10		10.65	0.394		0.419
e		1.27			0.050	
e3		11.43			0.450	
F	7.4		7.6	0.291		0.299
L	0.5		1.27	0.020		0.050
M			0.75			0.030
S	8 (max.)					



DIP20 PACKAGE MECHANICAL DATA

DIM.	mm			inch		
	MIN.	TYP.	MAX.	MIN.	TYP.	MAX.
a1	0.254			0.010		
B	1.39		1.65	0.055		0.065
b		0.45			0.018	
b1		0.25			0.010	
D			25.4			1.000
E		8.5			0.335	
e		2.54			0.100	
e3		22.86			0.900	
F			7.1			0.280
l			3.93			0.155
L		3.3			0.130	
Z			1.34			0.053

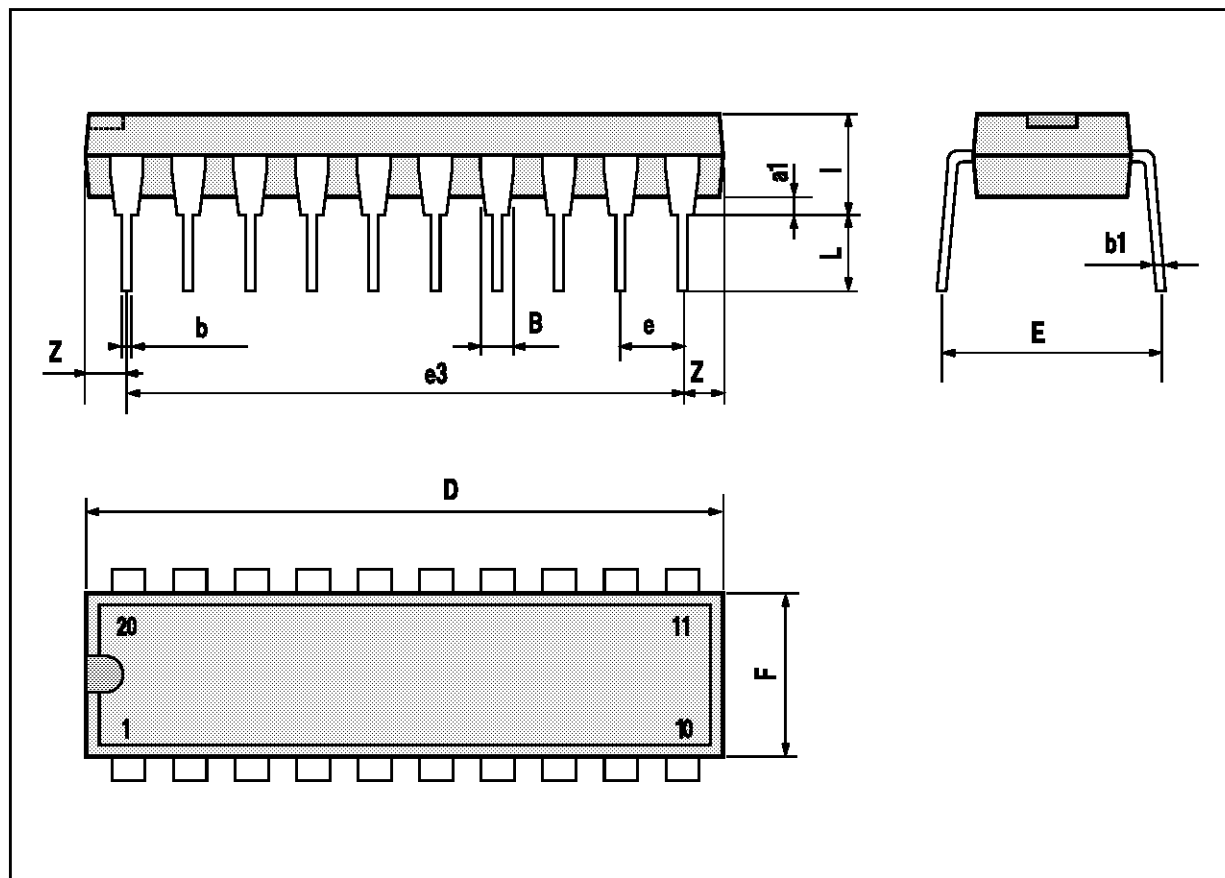

Information furnished is believed to be accurate and reliable. However, SGS-THOMSON Microelectronics assumes no responsibility for the consequences of use of such information nor for any infringement of patents or other rights of third parties which may result from its use. No license is granted by implication or otherwise under any patent or patent rights of SGS-THOMSON Microelectronics. Specifications mentioned in this publication are subject to change without notice. This publication supersedes and replaces all information previously supplied. SGS-THOMSON Microelectronics products are not authorized for use as critical components in life support devices or systems without express written approval of SGS-THOMSON Microelectronics.

© 1994 SGS-THOMSON Microelectronics - All Rights Reserved

SGS-THOMSON Microelectronics GROUP OF COMPANIES

Australia - Brazil - France - Germany - Hong Kong - Italy - Japan - Korea - Malaysia - Malta - Morocco - The Netherlands - Singapore - Spain - Sweden - Switzerland - Taiwan - Thailand - United Kingdom - U.S.A.