

SANYO	No. ※ 5560B	LC19001A010
		Digitizer Controller

Preliminary

Overview

The LC19001A010 provides rapid and precise position detection for the resistive membrane pressure-sensitive digitizers used in PDAs and other portable information-processing equipment. It implements, in a single chip, the coordinate readout processing required for pen input operations.

This controller provides the following functions: digitizer voltage A/D conversion, noise exclusion, conversion to display coordinates, and data transfer to the host CPU.

Features

- Detects input coordinate values from resistive membrane pressure-sensitive digitizers at readout speeds up to 190 points per second using a 10-bit A/D converter.
- Compact size, low power, and the 3.3 V power supply operation appropriate for PDAs and other portable information-processing equipment
- Menu area registration, duplicate coordinate processing, and 4-byte packets reduce the host CPU processing load.
- Logical exclusion of abnormal coordinates and averaging processing to remove both pen chattering noise and noise from the LCD system
- Controller functions can be programmed by sending command data from the host CPU.

Package Dimensions

unit: mm

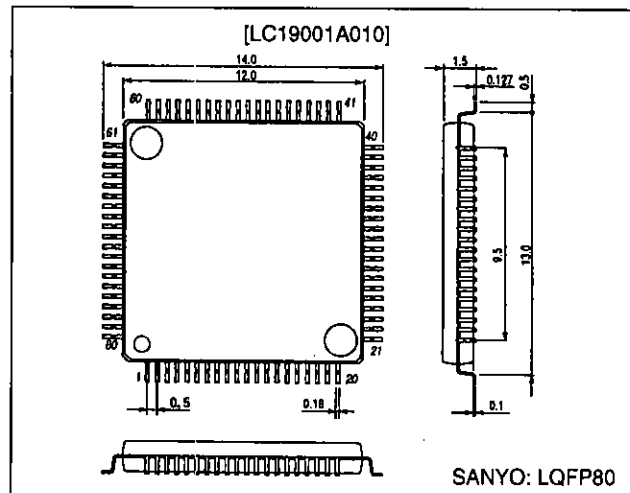
3326-LQFP80

LC19001A010

Pin Assignment

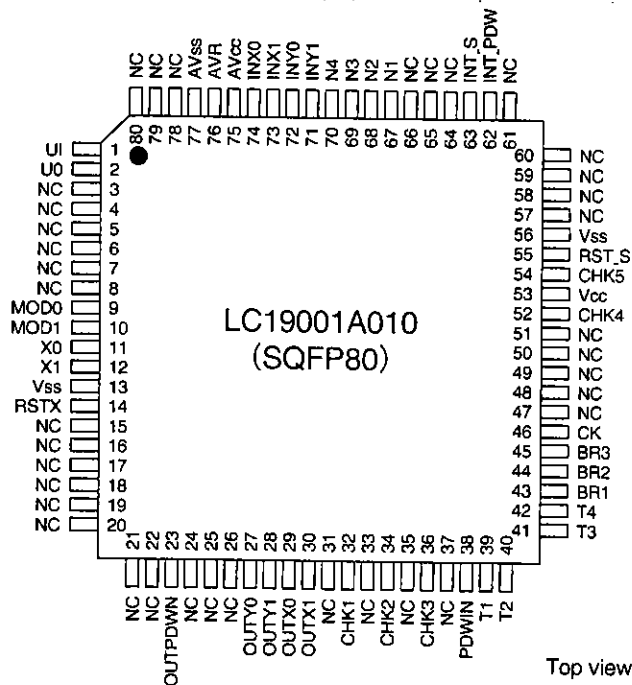

Block Diagram

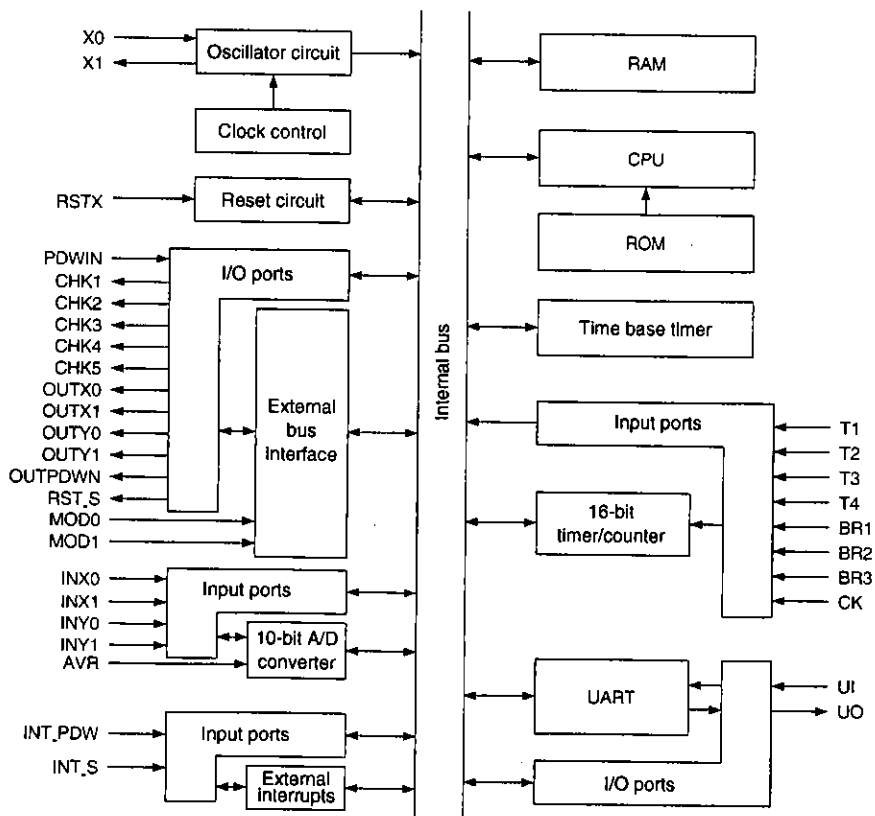

LC19001A010

Pin Functions

Pin No.	Pin	I/O	Function
1	UI	In	RS-232C receive data input (CMOS level)
2	UO	Out	RS-232C send data output (CMOS level)
3	NC	Out	
4	NC	Out	
5	NC	Out	
6	NC	Out	
7	NC	Out	
8	NC	Out	
9	MOD0	In	GND
10	MOD1	In	GND
11	X0		Clock oscillator connection
12	X1		Clock oscillator connection
13	V _{SS}		GND
14	RSTX	In	Reset input (active low)
15	NC	Out	
16	NC	Out	
17	NC	Out	
18	NC	Out	
19	NC	Out	
20	NC	Out	
21	NC	Out	
22	NC	Out	
23	OUTPDWN	Out	Pen down switch output port
24	NC	In	
25	NC	In	
26	NC	In	
27	OUTY0	Out	Digitizer electrode switching output: Y (Y0)
28	OUTY1	Out	Digitizer electrode switching output: Y (Y1)
29	OUTX0	Out	Digitizer electrode switching output: X (X0)
30	OUTX1	Out	Digitizer electrode switching output: X (X1)
31	NC	In	
32	CHK1	Out	Internal state verification output port 1
33	NC	In	
34	CHK2	Out	Internal state verification output port 2
35	NC	In	
36	CHK3	Out	Internal state verification output port 3
37	NC	In	
38	PDWIN	In	Pen down level detection
39	T1	In	Communication format setting input port 1
40	T2	In	Communication format setting input port 2
41	T3	In	Communication format setting input port 3
42	T4	In	Communication format setting input port 4

Continued on next page

LC19001A010

Continued from preceding page

Pin No.	Pin	I/O	Function
43	BR1	In	Baud rate setting input port 1
44	BR2	In	Baud rate setting input port 2
45	BR3	In	Baud rate setting input port 3
46	CK	In	Operating frequency setting input port (See the external switch settings)
47	NC	In	
48	NC	In	
49	NC	In	
50	NC	In	
51	NC	In	
52	CHK4	Out	Internal state verification output port 4. (High in sleep or stop modes)
53	V _{CC}		Power supply
54	CHK5	Out	Internal state verification output port 5
55	RST_S	Out	Reset notification signal
56	V _{SS}		GND
57	NC	Out	
58	NC	Out	
59	NC	In	
60	NC	In	
61	NC	In	
62	INT_PDW	In	Pen down interrupt (level)
63	INT_S	In	Stop mode clear interrupt (Connect with UI)
64	NC	In	
65	NC	In	
66	NC	In	
67	NC	In	GND
68	NC	In	GND
69	NC	In	GND
70	NC	In	GND
71	INY1	In	Digitizer analog input: Y (Y1)
72	INY0	In	Digitizer analog input: Y (Y0)
73	INX1	In	Digitizer analog input: X (X1)
74	INX0	In	Digitizer analog input: X (X0)
75	AV _{CC}		Analog system power supply (A/D converter power supply)
76	AVR	In	A/D converter reference voltage input
77	AV _{SS}		Analog system ground (A/D converter ground)
78	NC	In	
79	NC	Out	
80	NC	Out	

Specifications
Absolute Maximum Ratings

Parameter	Symbol	Conditions	Rated value		Unit
			min	max	
Supply voltage	V _{CC}		V _{SS} - 0.3	V _{SS} + 7.0	V
	AV _{CC}	Must not exceed V _{CC} . *1	V _{SS} - 0.3	V _{CC} + 0.3	V
A/D converter reference input voltage	AVR	Must not exceed AV _{CC} + 0.3 V.	V _{SS} - 0.3	V _{CC} + 0.3	V
Input voltage	V _I	*2	V _{SS} - 0.3	V _{CC} + 0.3	V
Output voltage	V _{O1}	*2	V _{SS} - 0.3	V _{CC} + 0.3	V
Maximum low-level output current	I _{OL}			20	mA
Average low-level output current	I _{OLAV}	The average value of (operating current x operating ratio)		4	mA
Maximum total low-level output current	ΣI _{OL}			100	mA
Average total low-level output current	ΣI _{OLAV}	The average value of (operating current x operating ratio)		40	mA
Maximum high-level output current	I _{OH}			-20	mA
Average high-level output current	I _{OHAV}	The average value of (operating current x operating ratio)		-4	mA
Maximum total high-level output current	ΣI _{OH}			-50	mA
Average total high-level output current	ΣI _{OHAV}	The average value of (operating current x operating ratio)		-20	mA
Power dissipation	Pd			300	mW
Operating temperature	Ta		-40	+85	°C
Storage temperature	Tstg		-55	+150	°C

Note: 1. The LC19001A010 must be used with AV_{CC} and V_{CC} at the same potential.
Also, applications must assure that AV_{CC} does not exceed V_{CC} at power on.
2. V_I and V_{O1} must not exceed V_{CC} + 0.3 V.

<Notes> This LSI can be permanently damaged by use at stresses in excess of the absolute maximum ratings.
It is desirable that the LC19001A010 be operated within the recommended operating conditions during normal operation. In particular, the LSI's reliability may be adversely affected if these conditions are exceeded.

Recommended Conditions at AV_{SS} = V_{SS} = 0 V

Parameter	Symbol	Conditions	Rated value		Unit
			min	max	
Supply voltage	V _{CC}	Guaranteed range for normal operation*	2.2*	6.0*	V
		RAM state retention in stop mode	1.5	6.0	V
A/D converter reference input voltage	AVR		0.0	AV _{CC}	V
Operating temperature	Ta		-40	+85	°C

Note: The guaranteed analog ranges vary with the frequency used.

DC Standards at Ta = -40 to 85°C

Parameter	Symbol	Pins	Conditions	Ratings			Unit	Operating frequency	
				min	typ	max			
Current drain	I _{CC1}	V _{CC}	Normal	V _{CC} = 5.0 V	12	20	mA	10 MHz	
	I _{CC2}			V _{CC} = 3.3 V		12	mA	8 MHz	
	I _{CCS1}		Sleep mode	V _{CC} = 5.0 V	3	7	mA	10 MHz	
	I _{CCS2}			V _{CC} = 3.3 V	1	1.5	mA	8 MHz	
	I _{CCH}		Stop mode	Ta = 25°C			1	μA	8 MHz
	I _A		AV _{CC}	A/D converter active			4	mA	8 MHz
I _{AH}	A/D converter stopped	Ta = 25°C				1	μA	10 MHz	
Input capacitance	Cin	Pins other than AV _{CC} , AV _{SS} , V _{CC} and V _{SS}	f = 1 MHz		10		pF		

LC19001A010

Digitizer Controller Provisional Specifications

*Initial values

Parameter	Function	Description												
Coordinate calculation method	Source data mode (Normalized data mode)*	A/D converted data is sent to the host CPU. Normalized data is sent to the host CPU.												
Interface	Serial communications	Asynchronous serial communications												
Communication rates (transfer rates)	1200, 2400, 4800, 9600, 19200 (bps)	External switches are used to set the initial communication rate. See the "External Switch Settings" charts. However, the LC19001A010 does not support 19200-bps communication at 8 MHz. The rate can be changed by command.												
Communication format	Data length: 8 bits Parity: none, even, odd Stop bits: 1 or 2	External switches are used to set the initial communication format. See the "External Switch Settings" charts.												
Output rate (sampling rate)	Can be set to an arbitrary value. Initial value 10 MHz: 100 P/S 8 MHz: 80 P/S	10 MHz: Maximum normalized data rate: 150 p/s Maximum source data rate: 190 p/s (When the baud rate is 19200) 8 MHz: Maximum normalized data rate: 120 p/s Maximum source data rate: 150 p/s (When the baud rate is 9600) Note: The above values apply when no menu area is registered.												
Coordinate data format	4-byte binary	See the "Coordinate Data Format" charts.												
Data output mode	Point (Stream)*	When the pen is down, coordinate values are output one point at a time. While the pen remains down, coordinate values are output continuously.												
Power dissipation (chip)	<table border="1"> <tr> <td>5-V drive</td> <td>140 mW (MAX)</td> <td>At a 10-MHz operating frequency, with the pen down</td> </tr> <tr> <td>3.3-V drive</td> <td>52.8 mW (MAX)</td> <td>At an 8-MHz operating frequency, with the pen down</td> </tr> </table>		5-V drive	140 mW (MAX)	At a 10-MHz operating frequency, with the pen down	3.3-V drive	52.8 mW (MAX)	At an 8-MHz operating frequency, with the pen down						
5-V drive	140 mW (MAX)	At a 10-MHz operating frequency, with the pen down												
3.3-V drive	52.8 mW (MAX)	At an 8-MHz operating frequency, with the pen down												
Low power functions	<ul style="list-style-type: none"> Events that recover from sleep mode: Pen down, reset, command reception Events that recover from stop mode: Pen down, reset, stop clear command 	<table border="1"> <thead> <tr> <th>Chip power dissipation</th> <th>Sleep mode</th> <th>Stop mode</th> <th>Operating frequency</th> </tr> </thead> <tbody> <tr> <td>5-V drive</td> <td>35 mW (MAX)</td> <td>5 μW (MAX)</td> <td>10 MHz</td> </tr> <tr> <td>3.3-V drive</td> <td>4.95 mW (MAX)</td> <td>3.3 μW (MAX)</td> <td>8 MHz</td> </tr> </tbody> </table> <p>Sleep: CPU operation is stopped, but all other circuits operate. Stop: The oscillator circuit is stopped.</p>	Chip power dissipation	Sleep mode	Stop mode	Operating frequency	5-V drive	35 mW (MAX)	5 μW (MAX)	10 MHz	3.3-V drive	4.95 mW (MAX)	3.3 μW (MAX)	8 MHz
Chip power dissipation	Sleep mode	Stop mode	Operating frequency											
5-V drive	35 mW (MAX)	5 μW (MAX)	10 MHz											
3.3-V drive	4.95 mW (MAX)	3.3 μW (MAX)	8 MHz											
	Methods for switching modes:	There are two types of command that are used to switch to the low power modes as follows: Direct: The LC19001A010 switches to the low power mode after the command is accepted. Auto: After the last coordinate input, if there is no input for a preset time, the LC19001A010 switches to the low power mode.												
	Direct													
	Auto													
	Transition times	<ul style="list-style-type: none"> Transition from normal mode to low power mode: about 5 μs Transition from low power mode to normal mode: Sleep mode: about 5 μs Stop mode: The oscillator stabilization period plus 5 μs 												
Drive voltage	3.3 to 6 V	An 8 MHz clock frequency must be used when the drive voltage is 3.3 V.												
Clock frequency	8 MHz, 10 MHz													
Package	LQFP80 (SQFP80)													
Chip size (mm)	14 × 14 × 1.5													
A/D converter resolution	10-bit	Linearity error: ±2 LSB (5 V, 10 MHz operation) Linearity error: ±2 LSB (3.3 V, 8 MHz operation)												

Continued on next page.

LC19001A010

Continued from preceding page.

Parameter	Function	Description
Reset	Hardware reset Software reset Power on reset	There are four types of reset: hardware reset, software reset, power on reset, and watchdog reset. Operation starts after the oscillator stabilization period has elapsed when stop mode is cleared and after a power on reset.
	Watchdog reset	A reset function operates automatically if the application software fails.
Status diagnostic function	Control setting state verification	Sends the controller's current state of the settings to the host CPU. Information sent includes the coordinate calculation method, the data output mode, and the output rate.
Interface diagnostic function	Interface verification	Uses arbitrary data to verify whether communication between the controller and the host CPU is functioning normally.
Menu area function	Menu area registration	A menu area can be registered at an arbitrary location. Up to 24 menu items can be registered.
Reference value setup function	Matching positions	Accepts A/D values and reference coordinate values from the host CPU for use in normalizing the A/D converted data and in matching positions.
Duplicate coordinate processing function	Duplicate coordinates are not transmitted	Compares the coordinate values transferred in the previous operation with the current coordinate data and if the coordinate values are the same (i.e., if they are duplicate coordinate values) the LC19001A010 does not send the current coordinate data. (Only valid in stream mode)
Timeout function	Sets the timeout time	If the required data was not received within the preset timeout time, the controller sends F3h to the host CPU.
Noise exclusion function	Sets the parameters used to reduce noise levels	Normally set to be about 10% of the number of pixels. (only valid in normalized mode) Initial values: X = 64, Y = 48
Lock function	Starts and clears the lock function	If a lock command is issued, after transmitting the coordinate data currently being transmitted, the controller halts transmission. The lock state is cleared by sending a lock clear command.

Coordinate Data Output Format: 4-byte structure

bit	7	6	5	4	3	2	1	0	
	Ph	0	0	P	X3	X2	X1	X0	First byte
	0	0	X9	X8	X7	X6	X5	X4	Second byte
	0	0	0	0	Y3	Y2	Y1	Y0	Third byte
	0	0	Y9	Y8	Y7	Y6	Y5	Y4	Fourth byte

- Ph: Phase bit, always set to 1.
 - 0: Zero bits, always cleared to 0.
 - X0 to X9: Horizontal axis value (X) as a binary value (X9 is the high-order bit)
 - Y0 to Y9: Vertical axis value (Y) as a binary value (Y9 is the high-order bit)
 - P: Pen status (pen down = 1, pen up = 0)
- When the pen is in the up state, the LC19001A010 sends a single byte with the value 80 h.

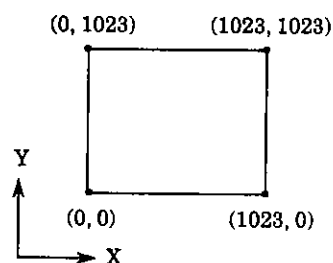

Menu Area Number Output Format: 1-byte structure

bit	7	6	5	4	3	2	1	0	
	Ph	1	0	M4	M3	M2	M1	M0	First byte

- Ph: Phase bit, always set to 1.
 - 1: One bit, always set to 1.
 - 0: Zero bit, always cleared to 0.
 - M0 to M4: Menu number M (range: 1 to 24) as a binary value (M4 is the high-order bit)
- When the pen is in the up state, the LC19001A010 sends a single byte with the value 80 h.

Note : Coordinate data and menu area data can be differentiated by inspecting bit 6. (See the data format descriptions above.)

External Switch Settings

Operating frequency

Pin No.	46
Frequency (MHz)	CK
10	L
8*	H

Note: Can not be used at 19200 bps.

Communication speed
(transfer rate)

Pin No.		43	44	45
Mode	Baud rate (bps)	BR1	BR2	BR3
0	1200	L	L	L
1	2400	H	L	L
2	4800	L	H	L
3	9600	L	L	H
4	19200	H	H	H

Communication
format

Pin No.			39	40	41	42	
Data length	Parity	Stop bits	T1	T2	T3	T4	
8 bits	None	1	L	L	L	H	
		2	L	L	L	L	
	Present	Even	1	L	H	L	L
			2	L	H	L	H
		Odd	1	L	H	H	L
			2	L	H	H	H

- No products described or contained herein are intended for use in surgical implants, life-support systems, aerospace equipment, nuclear power control systems, vehicles, disaster/crime-prevention equipment and the like, the failure of which may directly or indirectly cause injury, death or property loss.
- Anyone purchasing any products described or contained herein for an above-mentioned use shall:
 - ① Accept full responsibility and indemnify and defend SANYO ELECTRIC CO., LTD., its affiliates, subsidiaries and distributors and all their officers and employees, jointly and severally, against any and all claims and litigation and all damages, cost and expenses associated with such use:
 - ② Not impose any responsibility for any fault or negligence which may be cited in any such claim or litigation on SANYO ELECTRIC CO., LTD., its affiliates, subsidiaries and distributors or any of their officers and employees jointly or severally.
- Information (including circuit diagrams and circuit parameters) herein is for example only; it is not guaranteed for volume production. SANYO believes information herein is accurate and reliable, but no guarantees are made or implied regarding its use or any infringements of intellectual property rights or other rights of third parties.

This catalog provides information as of October, 1996. Specifications and information herein are subject to change without notice.