

SANYO

No. 4163A

256 K (32768 words × 8 bits) SRAM

Overview

The LC36256AL, AML are fully asynchronous silicon gate CMOS static RAMs with an 32768 words × 8 bits configuration.

This series have \overline{CE} chip enable pin for device select/nonselct control and an \overline{OE} output enable pin for output control, and features high speed as well as low power dissipation.

For these reasons, the series is especially suited for use in systems requiring high speed, low power, and battery backup, and it is easy to expand memory capacity.

Features

- Access time

70 ns (max.) : LC36256AL-70, LC36256AML-70

85 ns (max.) : LC36256AL-85, LC36256AML-85

100 ns (max.) : LC36256AL-10, LC36256AML-10

120 ns (max.) : LC36256AL-12, LC36256AML-12

- Low current dissipation

During standby

2 μ A (max.) / $T_a = 25^\circ\text{C}$

5 μ A (max.) / $T_a = 0$ to $+40^\circ\text{C}$

25 μ A (max.) / $T_a = 0$ to $+70^\circ\text{C}$

During data retention

1 μ A (max.) / $T_a = 25^\circ\text{C}$

2 μ A (max.) / $T_a = 0$ to $+40^\circ\text{C}$

10 μ A (max.) / $T_a = 0$ to $+70^\circ\text{C}$

During operation (DC)

10 mA (max.)

- Single 5 V power supply: 5 V \pm 10%
- Data retention power supply voltage: 2.0 to 5.5 V
- No clock required (Fully static memory)
- All input/output levels are TTL compatible
- Common input/output pins, with three output states
- Packages
 - DIP 28 -pin (600 mil) plastic package : LC36256AL
 - SOP 28-pin (450 mil) plastic package : LC36256AML

Package Dimensions

unit : mm

3012A - DIP28

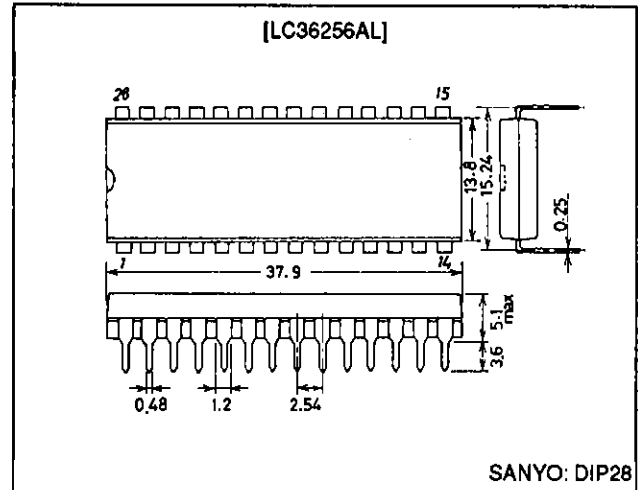

unit : mm

3187 - SOP28D

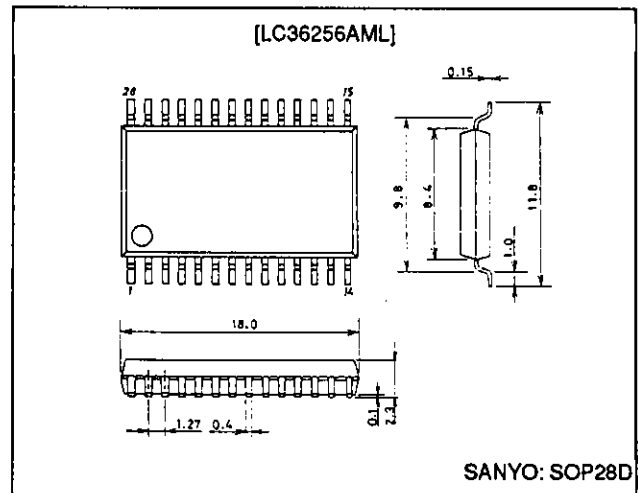

Pin Assignment

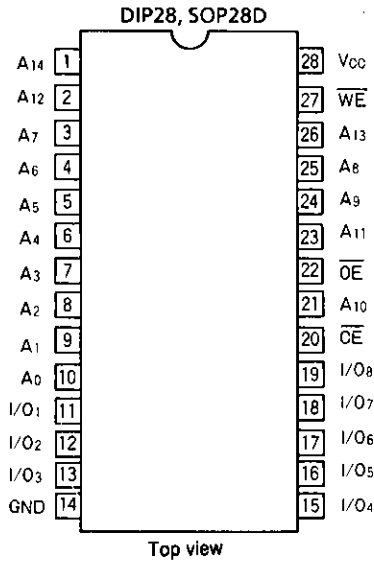

Block Diagram

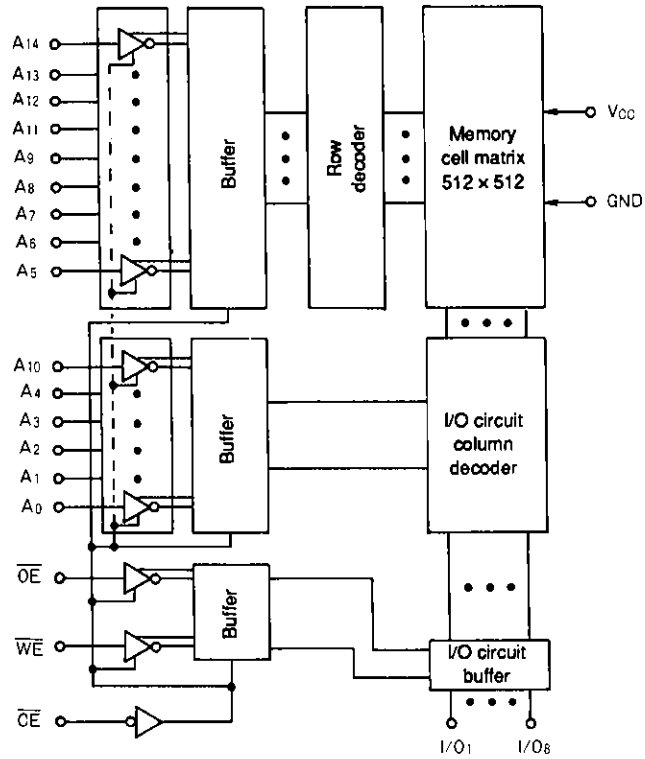

Pin Functions

A0 to A14	Address input
WE	Read/write control input
OE	Output enable input
CE	Chip enable input
I/O1 to I/O8	Data input/output
VCC, GND	Power supply pins

Functions

Mode	CE	OE	WE	I/O	Supply current
Read cycle	L	L	H	Data output	I _{CCA}
Write cycle	L	X	L	Data input	I _{CCA}
Output disable	L	H	H	High impedance	I _{CCA}
Nonselect	H	X	X	High impedance	I _{CCS}

X : H or L

Specifications

Absolute Maximum Ratings at $T_a=25^\circ\text{C}$

Parameter	Symbol	Conditions	Ratings	Unit
Maximum supply voltage	VCC max		7.0	V
Input pin voltage	V _{IN}		-0.5* to V _{CC} +0.5	V
I/O pin voltage	V _{I/O}		-0.5* to V _{CC} +0.5	V
Allowable power dissipation	Pd max	LC36256AL	1.0	W
		LC36256AML	0.7	W
Operating temperature range	Topr		0 to +70	°C
Storage temperature range	Tstg		-55 to +150	°C

* -3.0 V when pulse width is less than 50 ns

DC Recommended Operating Ranges at $T_a = 0$ to $+70^\circ\text{C}$

Parameter	Symbol	min	typ	max	Unit
Power supply voltage	VCC	4.5	5.0	5.5	V
Input high level voltage	V _{IH}	2.2		V _{CC} +0.3	V
Input low level voltage	V _{IL}	-0.3*		+0.8	V

* -3.0 V when pulse width is less than 50 ns

DC Electrical Characteristics at $T_a = 0$ to $+70^\circ\text{C}$, $V_{CC} = 5\text{ V} \pm 10\%$

Parameter	Symbol	Conditions		min	typ*	max	Unit
Input leakage current	I _{LI}	V _{IN} = 0 to V _{CC}		-0.5		+0.5	μA
I/O leakage current	I _{LO}	V _{CE} = V _{IH} or V _{CE} = V _{IH} , V _{I/O} = 0 to V _{CC}		-0.5		+0.5	μA
Output high level voltage	V _{OH}	I _{OH} = -1.0mA		2.4			V
Output low level voltage	V _{OL}	I _{OL} = 2.1mA				0.4	V
Operating supply current (DC)	I _{CCA1}	V _{CE} ≤ 0.2V, V _{IN} ≤ 0.2V or V _{IN} ≥ V _{CC} -0.2V			1	5	mA
	I _{CCA2}	V _{CE} = V _{IL} , I _{I/O} =0mA			3	10	mA
Average operating supply current	I _{CCA3}	min cycle Duty = 100% I _{I/O} = 0mA	Access time	70ns	30	50	mA
				85ns	25	50	
		100ns	23	50			
		120ns	20	50			
Standby supply current	I _{CCS1}	V _{CE} ≥ V _{CC} -0.2V		0 to +70°C		25	μA
				0 to +40°C		5	
	I _{CCS2}	V _{CE} = V _{IH}		25°C	0.5	2	
					0.4	2	mA

* Reference values at V_{CC} = 5 V, T_a = 25°C

Input/Output Capacitance at Ta = 25°C, f = 1 MHz

Parameter	Symbol	Conditions	min	typ	max	Unit
Input/output capacitance	C _{I/O}	V _{I/O} = 0V			8	pF
Input capacitance	C _{IN}	V _{IN} = 0V			6	pF

Note: These parameters were obtained through sampling, and not full-lot measurement.

AC Electrical Characteristics at Ta = 0 to +70°C, V_{CC} = 5 V ±10%

AC testing conditions

- Input pulse voltage level : 0.8 V, 2.2 V
- Input rise and fall time : 5 ns
- Input - output timing level : 1.5 V
- Output load : 1 TTL gate + C_L = 100 pF (85 ns/100 ns/120 ns)
1 TTL gate + C_L = 30 pF (70 ns)
(including scope and jig capacitance)

Read Cycle

Parameter	Symbol	LC36256AL, AML								Unit
		-70		-85		-10		-12		
		min	max	min	max	min	max	min	max	
Read cycle time	t _{RC}	70		85		100		120		ns
Address access time	t _{AA}		70		85		100		120	ns
CE access time	t _{CA}		70		85		100		120	ns
OE access time	t _{OA}		35		45		50		60	ns
Output hold time	t _{OH}	20		20		20		20		ns
CE output enable time	t _{COE}	10		10		10		10		ns
OE output enable time	t _{OOE}	5		5		5		5		ns
OE output disable time	t _{COD}	0	30	0	30	0	30	0	30	ns
OE output disable time	t _{OOD}	0	30	0	30	0	30	0	30	ns

Write Cycle

Parameter	Symbol	LC36256AL, AML								Unit
		-70		-85		-10		-12		
		min	max	min	max	min	max	min	max	
Write cycle time	t _{WC}	70		85		100		120		ns
Address valid to end of write	t _{AW}	65		75		80		100		ns
Address setup time	t _{AS}	0		0		0		0		ns
Write pulse width	t _{WP}	50		50		60		70		ns
CE setup time	t _{CW}	65		75		80		100		ns
Write recovery time (WE)	t _{WR}	0		0		0		0		ns
Write recovery time (CE)	t _{WR1}	0		0		0		0		ns
Data setup time	t _{DS}	30		30		35		40		ns
Data hold time	t _{DH}	0		0		0		0		ns
WE output enable time	t _{WOE}	10		10		10		10		ns
WE output disable time	t _{WOD}	0	25	0	25	0	25	0	25	ns

Timing Chart

- Read Cycle (1): $\overline{CE} = \overline{OE} = V_{IL}, \overline{WE} = V_{IH}$

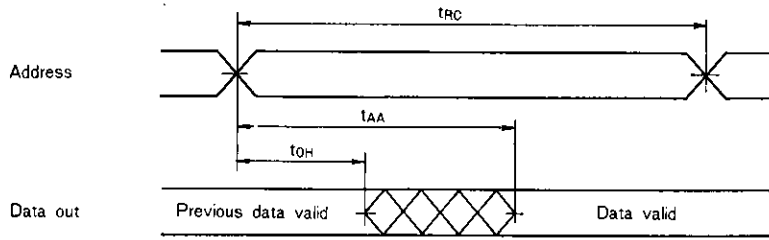

- Read Cycle (2): $\overline{WE} = V_{IH}$

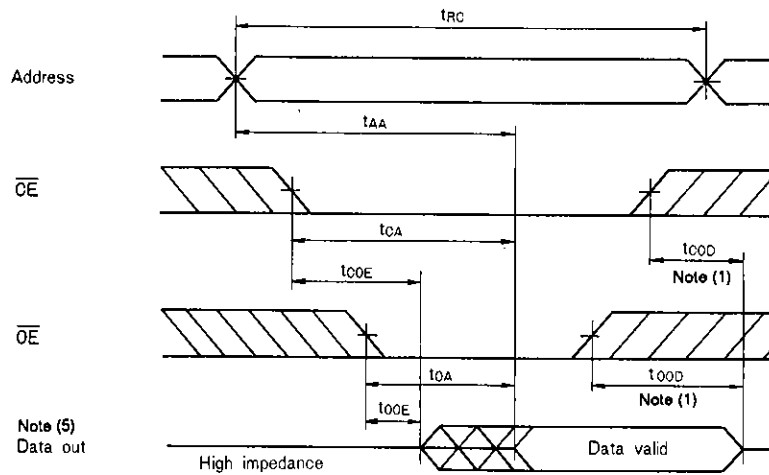

- Write Cycle (1): \overline{WE} Control Note (6)

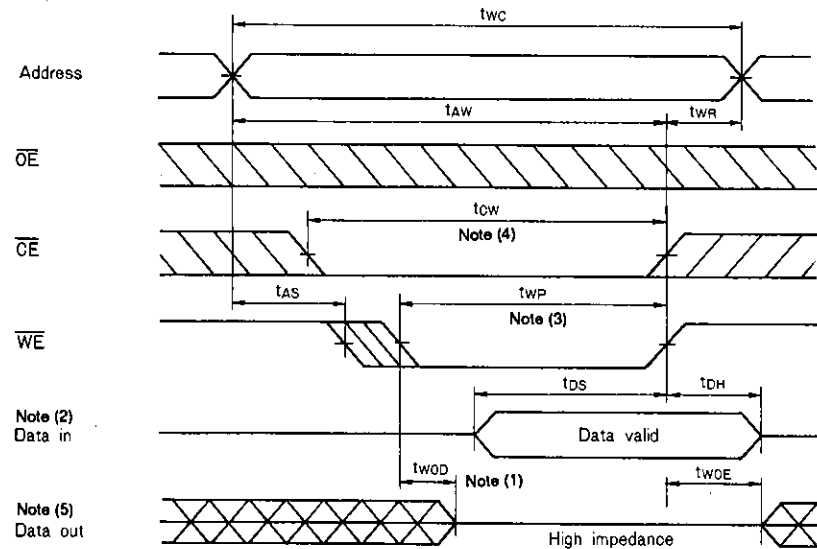

• Write Cycle (2): \overline{CE} Control Note (6)

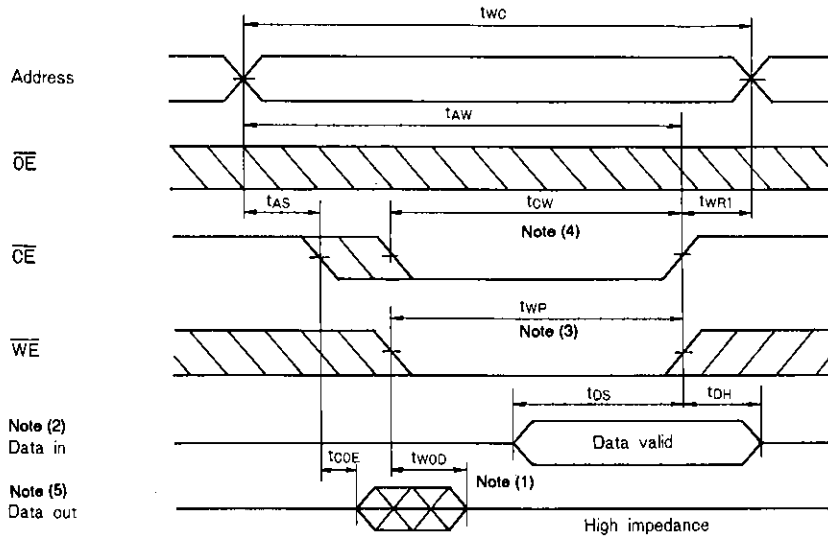

- Notes
- (1) t_{COD} , t_{OOD} , and t_{wOD} are defined as the time at which the outputs becomes the high impedance state and are not referred to output voltage levels.
 - (2) An external antiphase signal must not be applied when DOUT is in the output state.
 - (3) t_{WP} is the time interval that \overline{CE} and \overline{WE} are low-level and is defined as the interval from the falling of \overline{WE} to the rising of \overline{CE} or \overline{WE} whichever is earlier.
 - (4) t_{CW} is the time interval that \overline{CE} and \overline{WE} are low-level and is defined as the time from the falling of \overline{CE} to the rising of \overline{CE} or \overline{WE} whichever is earlier.
 - (5) DOUT goes to the high-impedance state when either \overline{OE} is high-level, \overline{CE} is high-level, or \overline{WE} is low-level.
 - (6) When \overline{OE} is high-level during the write cycle, DOUT goes to the high-impedance state.

Data Retention Characteristics at $T_a = 0$ to $+70^\circ\text{C}$

Parameter	Symbol	Conditions	min	typ*	max	Unit
Data retention supply voltage	VDR	$V_{CE} \geq V_{CC} - 0.2V$	2.0		5.5	V
Data retention supply current	ICCDR1	$V_{CC} = 3.0V,$ $V_{CE} \geq 2.8V$	0 to $+70^\circ\text{C}$		10	μA
			0 to $+40^\circ\text{C}$		2	
			25 $^\circ\text{C}$	0.25	1	
	ICCDR2	$V_{CC} = 2.0$ to $5.5V,$ $V_{CE} \geq V_{CC} - 0.2V$		0.5	25	μA
CE setup time	t_{CDR}		0			ns
CE hold time	t_R		t_{RC}^{**}			ns

* Reference values at $V_{CC} = 5V, T_a = 25^\circ\text{C}$ ** t_{RC} = Read Cycle time

Data Retention Waveform

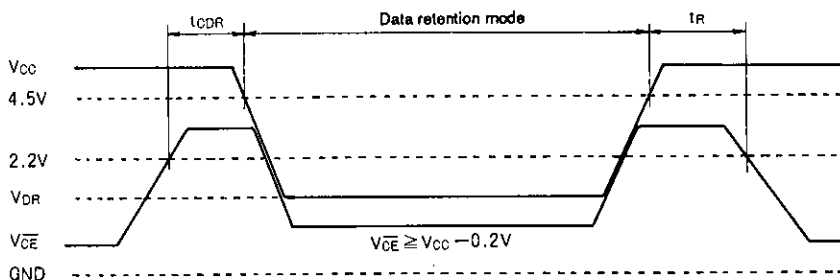

- No products described or contained herein are intended for use in surgical implants, life-support systems, aerospace equipment, nuclear power control systems, vehicles, disaster/crime-prevention equipment and the like, the failure of which may directly or indirectly cause injury, death or property loss.
- Anyone purchasing any products described or contained herein for an above-mentioned use shall:
 - ① Accept full responsibility and indemnify and defend SANYO ELECTRIC CO., LTD., its affiliates, subsidiaries and distributors and all their officers and employees, jointly and severally, against any and all claims and litigation and all damages, cost and expenses associated with such use:
 - ② Not impose any responsibility for any fault or negligence which may be cited in any such claim or litigation on SANYO ELECTRIC CO., LTD., its affiliates, subsidiaries and distributors or any of their officers and employees jointly or severally.
- Information (including circuit diagrams and circuit parameters) herein is for example only; it is not guaranteed for volume production. SANYO believes information herein is accurate and reliable, but no guarantees are made or implied regarding its use or any infringements of intellectual property rights or other rights of third parties.

This catalog provides information as of February, 1996. Specifications and information herein are subject to change without notice.