

LM2907/LM2917 Frequency to Voltage Converter

General Description

The LM2907, LM2917 series are monolithic frequency to voltage converters with a high gain op amp/comparator designed to operate a relay, lamp, or other load when the input frequency reaches or exceeds a selected rate. The tachometer uses a charge pump technique and offers frequency doubling for low ripple, full input protection in two versions (LM2907-8, LM2917-8) and its output swings to ground for a zero frequency input.

The op amp/comparator is fully compatible with the tachometer and has a floating transistor as its output. This feature allows either a ground or supply referred load of up to 50 mA. The collector may be taken above V_{CC} up to a maximum V_{CE} of 28V.

The two basic configurations offered include an 8-pin device with a *ground referenced tachometer* input and an internal connection between the tachometer output and the op amp non-inverting input. This version is well suited for single speed or frequency switching or fully buffered frequency to voltage conversion applications.

The more versatile configurations provide differential tachometer input and uncommitted op amp inputs. With this version the tachometer input may be floated and the op amp becomes suitable for active filter conditioning of the tachometer output.

Both of these configurations are available with an active shunt regulator connected across the power leads. The regulator clamps the supply such that stable frequency to voltage and frequency to current operations are possible with any supply voltage and a suitable resistor.

Advantages

- Output swings to ground for zero frequency input

- Easy to use; $V_{OUT} = f_{IN} \times V_{CC} \times R1 \times C1$
- Only one RC network provides frequency doubling
- Zener regulator on chip allows accurate and stable frequency to voltage or current conversion (LM2917)

Features

- Ground referenced tachometer input interfaces directly with variable reluctance magnetic pickups
- Op amp/comparator has floating transistor output
- 50 mA sink or source to operate relays, solenoids, meters, or LEDs
- Frequency doubling for low ripple
- Tachometer has built-in hysteresis with either differential input or ground referenced input
- Built-in zener on LM2917
- $\pm 0.3\%$ linearity typical
- Ground referenced tachometer is fully protected from damage due to swings above V_{CC} and below ground

Applications

- Over/under speed sensing
- Frequency to voltage conversion (tachometer)
- Speedometers
- Breaker point dwell meters
- Hand-held tachometer
- Speed governors
- Cruise control
- Automotive door lock control
- Clutch control
- Horn control
- Touch or sound switches

Block and Connection Diagrams Dual-In-Line and Small Outline Packages, Top Views

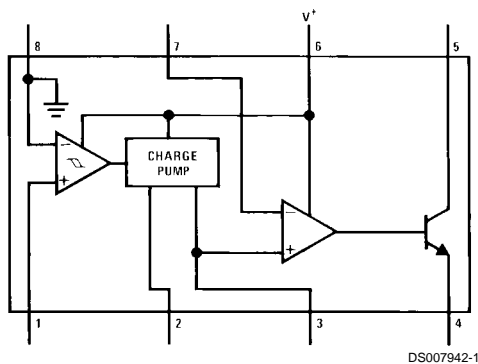

Order Number LM2907M-8 or LM2907N-8
See NS Package Number M08A or N08E

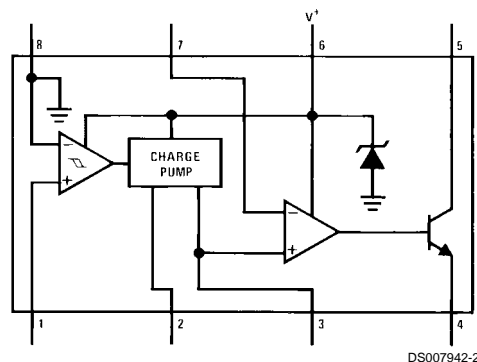

Order Number LM2917M-8 or LM2917N-8
See NS Package Number M08A or N08E

Absolute Maximum Ratings (Note 1)

If Military/Aerospace specified devices are required, please contact the National Semiconductor Sales Office/Distributors for availability and specifications.

Supply Voltage	28V
Supply Current (Zener Options)	25 mA
Collector Voltage	28V
Differential Input Voltage	
Tachometer	28V
Op Amp/Comparator	28V
Input Voltage Range	
Tachometer	
LM2907-8, LM2917-8	±28V
LM2907, LM2917	0.0V to +28V
Op Amp/Comparator	0.0V to +28V

Power Dissipation

LM2907-8, LM2917-8	1200 mW
LM2907-14, LM2917-14	1580 mW
See (Note 1)	

Operating Temperature Range	-40°C to +85°C
Storage Temperature Range	-65°C to +150°C

Soldering Information

Dual-In-Line Package	
Soldering (10 seconds)	260°C
Small Outline Package	
Vapor Phase (60 seconds)	215°C
Infrared (15 seconds)	220°C

See AN-450 "Surface Mounting Methods and Their Effect on Product Reliability" for other methods of soldering surface mount devices.

Electrical Characteristics

$V_{CC} = 12 V_{DC}$, $T_A = 25^\circ C$, see test circuit

Symbol	Parameter	Conditions	Min	Typ	Max	Units
TACHOMETER						
	Input Thresholds	$V_{IN} = 250 \text{ mVp-p @ 1 kHz}$ (Note 2)	±10	±25	±40	mV
	Hysteresis	$V_{IN} = 250 \text{ mVp-p @ 1 kHz}$ (Note 2)		30		mV
	Offset Voltage	$V_{IN} = 250 \text{ mVp-p @ 1 kHz}$ (Note 2)				
	LM2907/LM2917			3.5	10	mV
	LM2907-8/LM2917-8			5	15	mV
	Input Bias Current	$V_{IN} = \pm 50 \text{ mV}_{DC}$		0.1	1	µA
V_{OH}	Pin 2	$V_{IN} = +125 \text{ mV}_{DC}$ (Note 3)		8.3		V
V_{OL}	Pin 2	$V_{IN} = -125 \text{ mV}_{DC}$ (Note 3)		2.3		V
I_2, I_3	Output Current	$V_2 = V_3 = 6.0V$ (Note 4)	140	180	240	µA
I_3	Leakage Current	$I_2 = 0, V_3 = 0$			0.1	µA
K	Gain Constant	(Note 3)	0.9	1.0	1.1	
	Linearity	$f_{IN} = 1 \text{ kHz}, 5 \text{ kHz}, 10 \text{ kHz}$ (Note 5)	-1.0	0.3	+1.0	%
OP/AMP COMPARATOR						
V_{OS}		$V_{IN} = 6.0V$		3	10	mV
I_{BIAS}		$V_{IN} = 6.0V$		50	500	nA
	Input Common-Mode Voltage		0		$V_{CC} - 1.5V$	V
	Voltage Gain			200		V/mV
	Output Sink Current	$V_C = 1.0$	40	50		mA
	Output Source Current	$V_E = V_{CC} - 2.0$		10		mA
	Saturation Voltage	$I_{SINK} = 5 \text{ mA}$		0.1	0.5	V
		$I_{SINK} = 20 \text{ mA}$			1.0	V
		$I_{SINK} = 50 \text{ mA}$		1.0	1.5	V
ZENER REGULATOR						
	Regulator Voltage	$R_{DROP} = 470\Omega$		7.56		V
	Series Resistance			10.5	15	Ω
	Temperature Stability			+1		mV/°C
	TOTAL SUPPLY CURRENT			3.8	6	mA

Note 1: For operation in ambient temperatures above 25°C, the device must be derated based on a 150°C maximum junction temperature and a thermal resistance of 101°C/W junction to ambient for LM2907-8 and LM2917-8, and 79°C/W junction to ambient for LM2907-14 and LM2917-14.

Note 2: Hysteresis is the sum $+V_{TH} - (-V_{TH})$, offset voltage is their difference. See test circuit.

Note 3: V_{OH} is equal to $\frac{3}{4} \times V_{CC} - 1 V_{BE}$, V_{OL} is equal to $\frac{1}{4} \times V_{CC} - 1 V_{BE}$ therefore $V_{OH} - V_{OL} = V_{CC}/2$. The difference, $V_{OH} - V_{OL}$, and the mirror gain, I_2/I_3 , are the two factors that cause the tachometer gain constant to vary from 1.0.

Note 4: Be sure when choosing the time constant $R1 \times C1$ that $R1$ is such that the maximum anticipated output voltage at pin 3 can be reached with $I_3 \times R1$. The maximum value for $R1$ is limited by the output resistance of pin 3 which is greater than 10 MΩ typically.

Electrical Characteristics (Continued)

Note 5: Nonlinearity is defined as the deviation of V_{OUT} (@ pin 3) for $f_{IN} = 5$ kHz from a straight line defined by the V_{OUT} @ 1 kHz and V_{OUT} @ 10 kHz. $C1 = 1000$ pF, $R1 = 68k$ and $C2 = 0.22$ mFd.

Test Circuit and Waveform

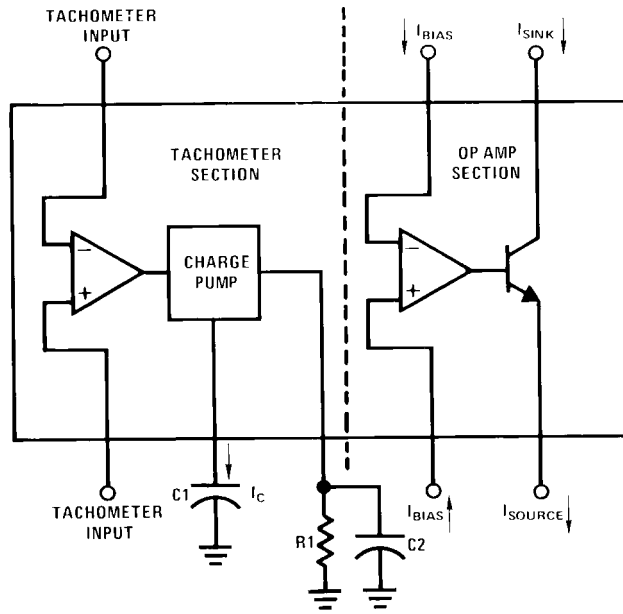

DS007942-6

Tachometer Input Threshold Measurement

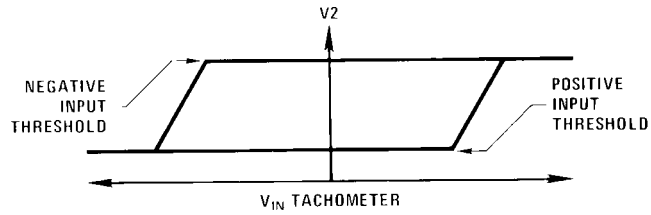

DS007942-7

Typical Applications

Minimum Component Tachometer

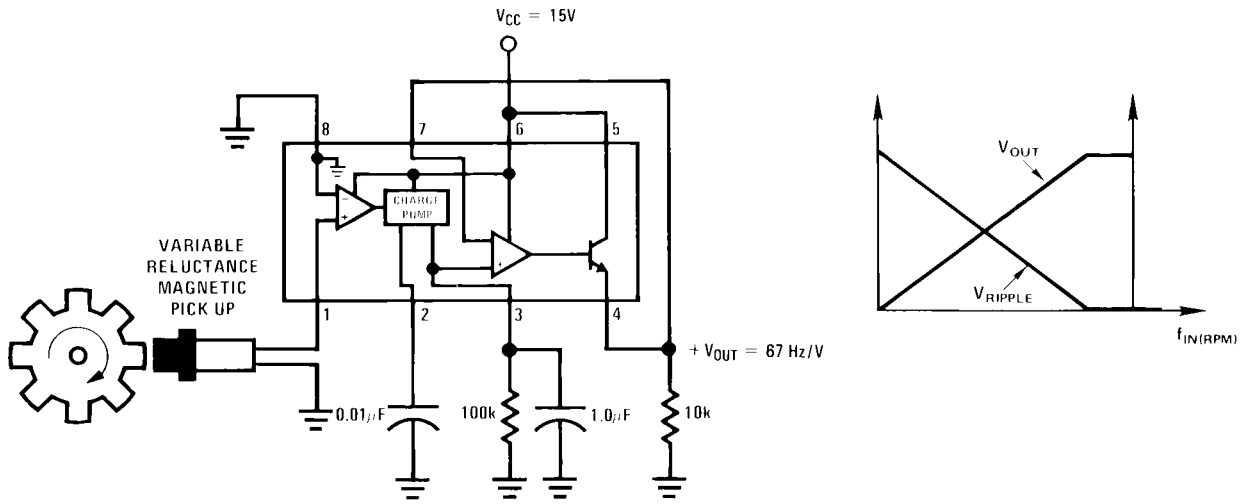

DS007942-8

"Speed Switch" Load is Energized When $f_{IN} \geq \frac{1}{2RC}$

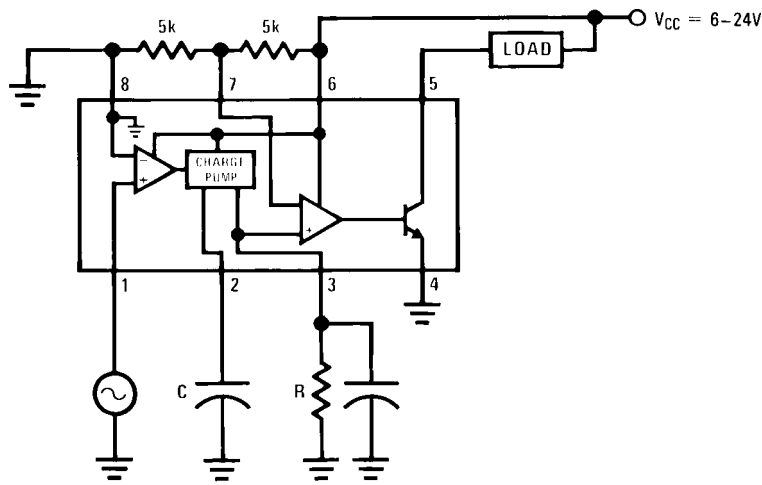

DS007942-9

Typical Applications (Continued)

Zener Regulated Frequency to Voltage Converter

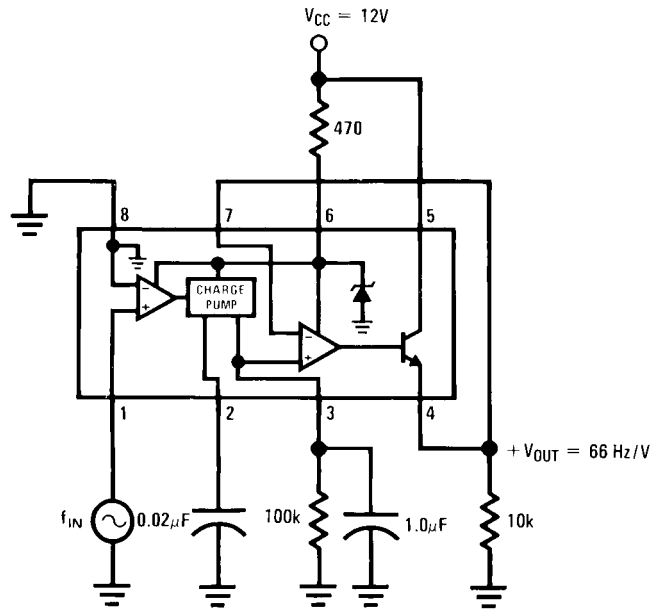

DS007942-10

Breaker Point Dwell Meter

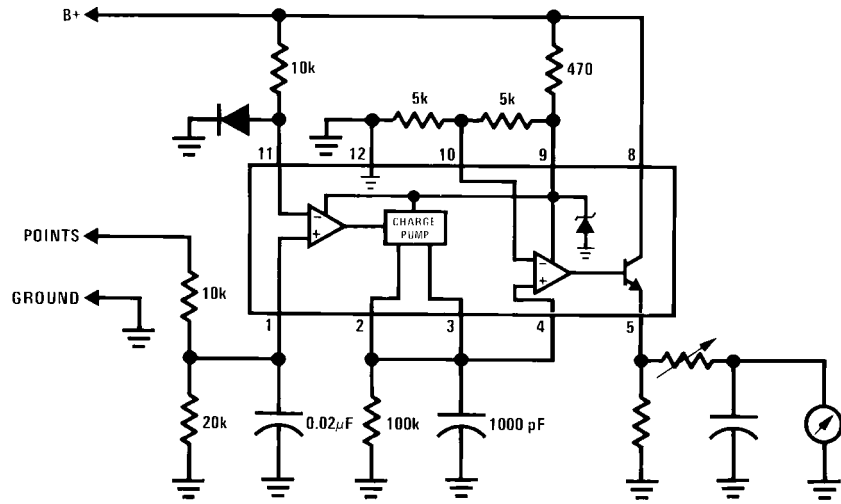

DS007942-11

Typical Applications (Continued)

Voltage Driven Meter Indicating Engine RPM
 $V_o = 6V @ 400 \text{ Hz or } 6000 \text{ ERPM (8 Cylinder Engine)}$

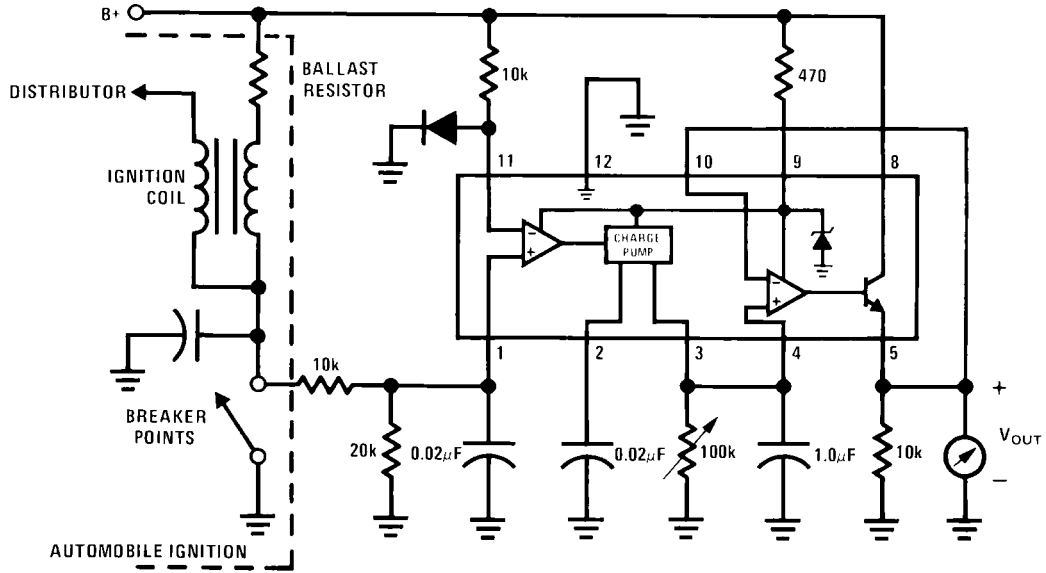

DS007942-12

Current Driven Meter Indicating Engine RPM
 $I_o = 10 \text{ mA @ } 300 \text{ Hz or } 6000 \text{ ERPM (6 Cylinder Engine)}$

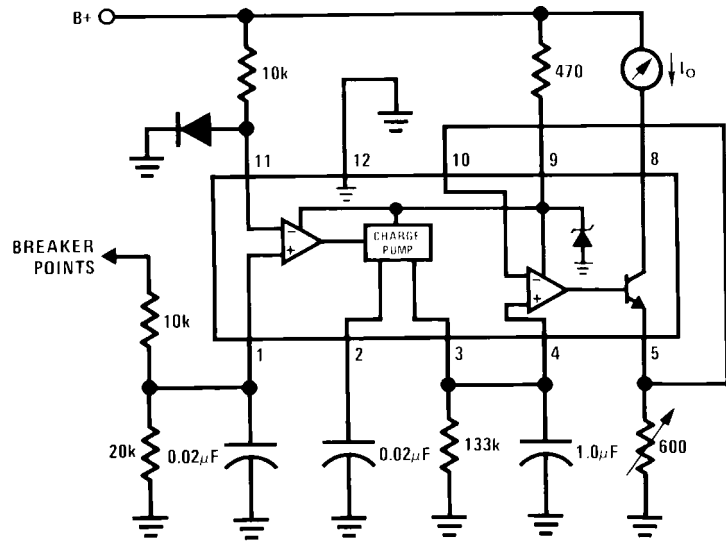

DS007942-13

Typical Applications (Continued)

Capacitance Meter
 $V_{OUT} = 1V-10V$ for $C_X = 0.01$ to 0.1 mFd
 $(R = 111k)$

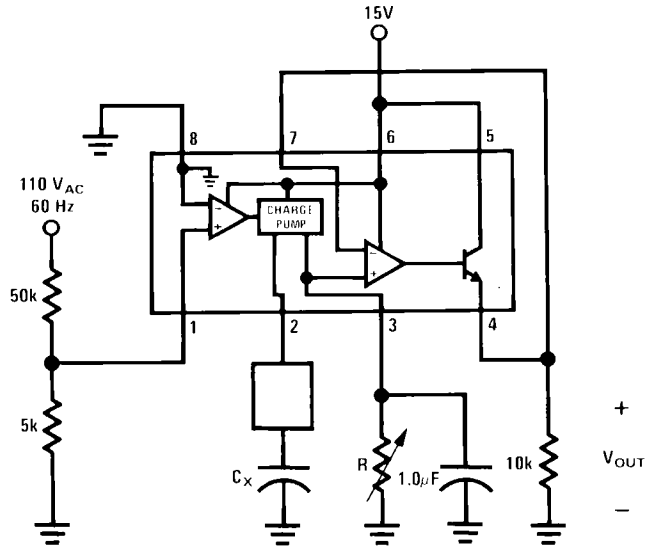

DS007942-14

Two-Wire Remote Speed Switch

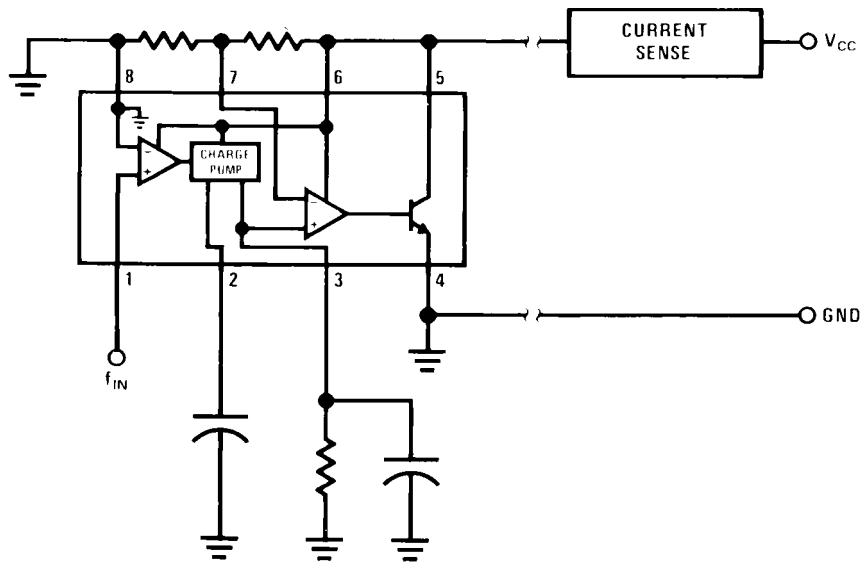

DS007942-15

Typical Applications (Continued)

100 Cycle Delay Switch

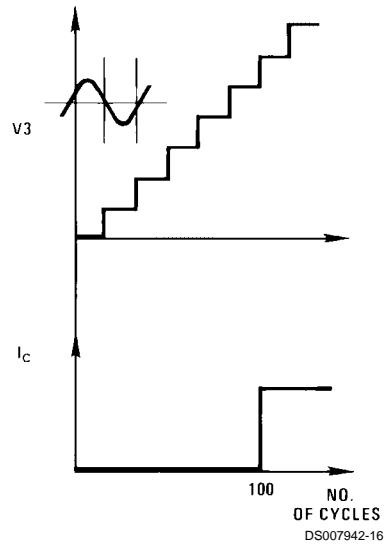
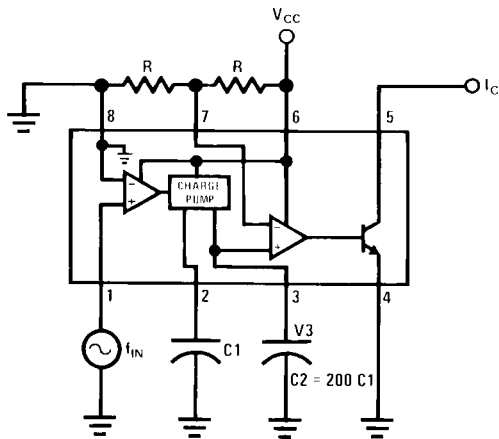

V3 steps up in voltage by the amount $\frac{V_{CC} \times C1}{C2}$ for each complete input cycle (2 zero crossings)

Example:

if $C2 = 200 C1$ after 100 consecutive input cycles.

$$V3 = 1/2 V_{CC}$$

Variable Reluctance Magnetic Pickup Buffer Circuits

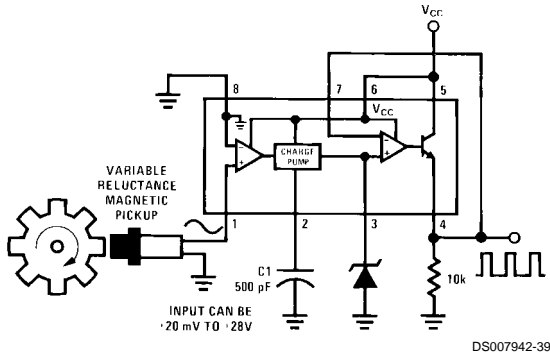

Precision two-shot output frequency equals twice input frequency.

$$\text{Pulse width} = \frac{V_{CC}}{2} \frac{C1}{I2}$$

$$\text{Pulse height} = V_{ZENER}$$

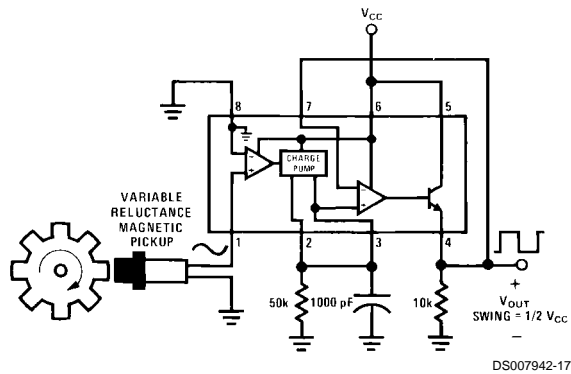

Typical Applications (Continued)

Finger Touch or Contact Switch

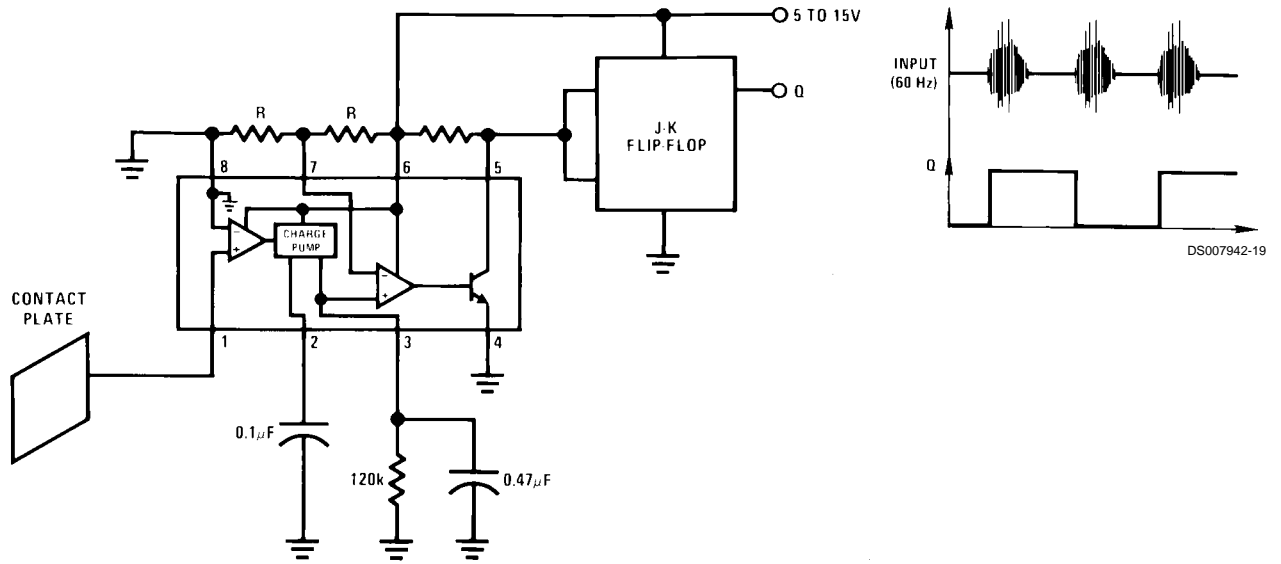

Flashing LED Indicates Overspeed

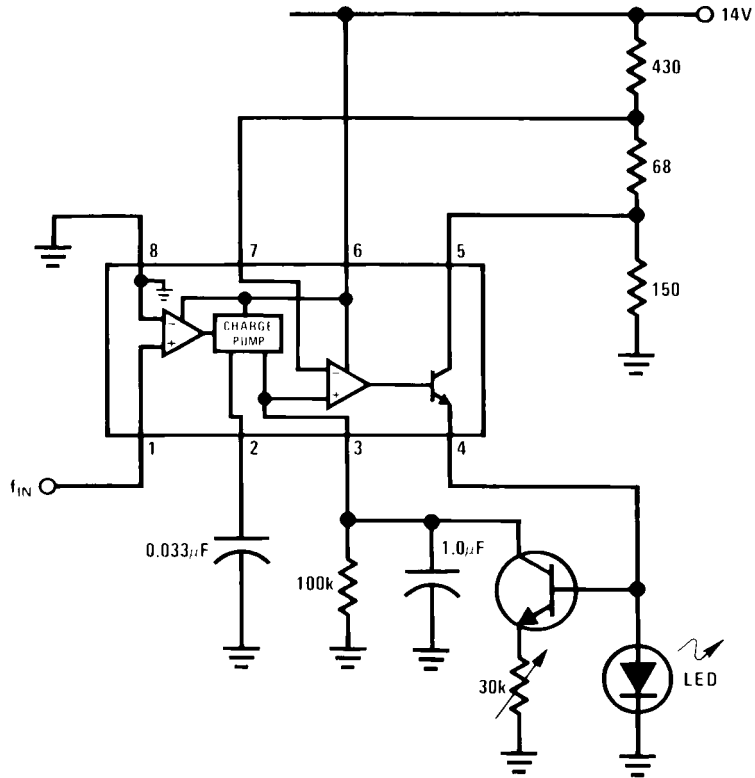

Flashing begins when $f_{IN} \geq 100$ Hz.
Flash rate increases with input frequency increase beyond trip point.

Typical Applications (Continued)

Frequency to Voltage Converter with 2 Pole Butterworth Filter to Reduce Ripple

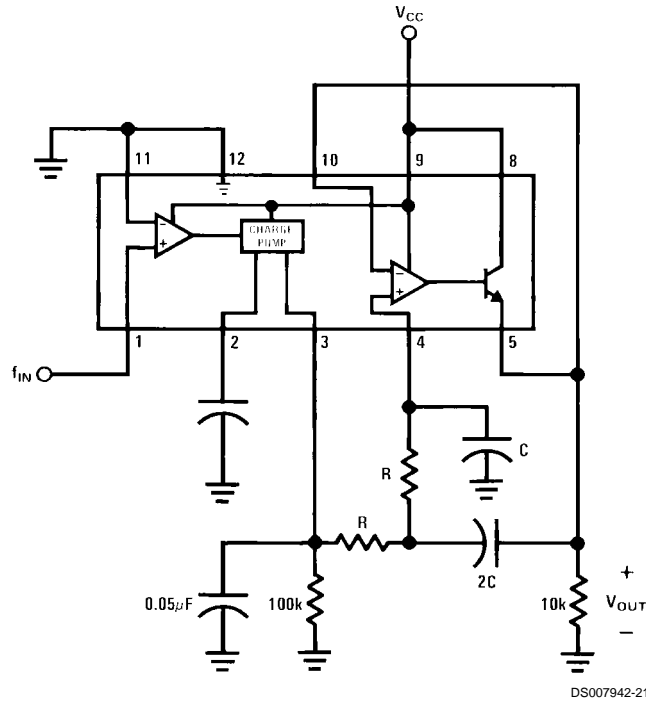

DS007942-21

$$f_{POLE} = \frac{0.707}{2\pi RC}$$

$$\tau_{RESPONSE} = \frac{2.57}{2\pi f_{POLE}}$$

Overspeed Latch

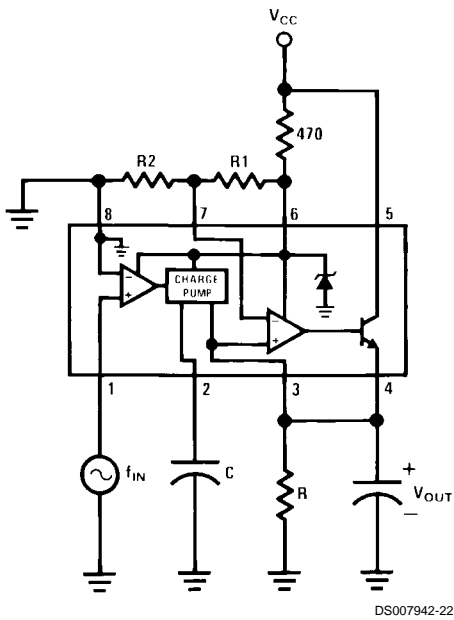

DS007942-22

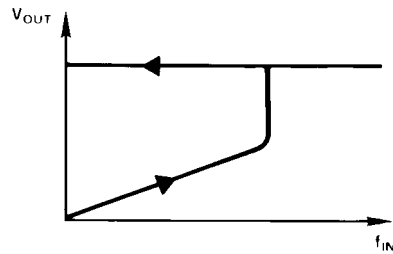

DS007942-23

Output latches when

$$f_{IN} = \frac{R2}{R1 + R2} \frac{1}{RC}$$

Reset by removing V_{CC}.

Typical Applications (Continued)

Some Frequency Switch Applications May Require Hysteresis in the Comparator Function Which can be Implemented in Several Ways:

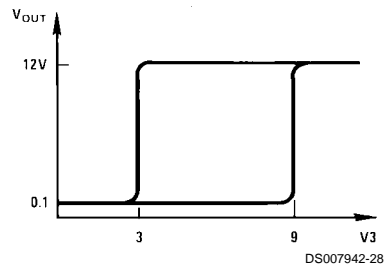
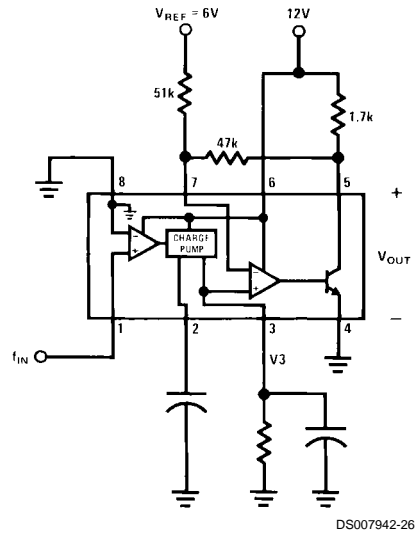
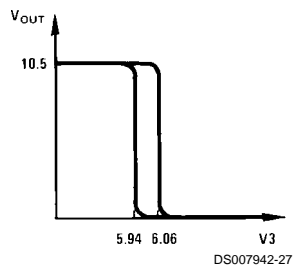
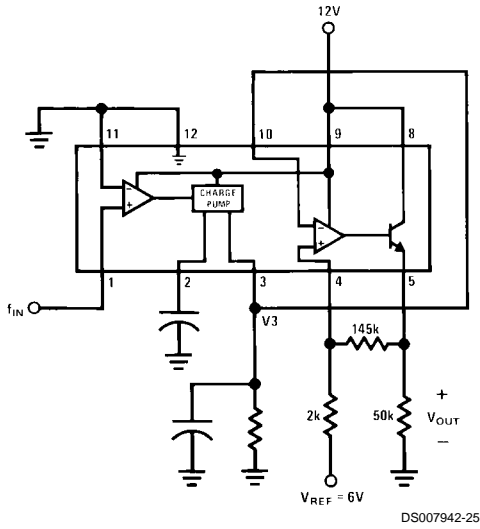
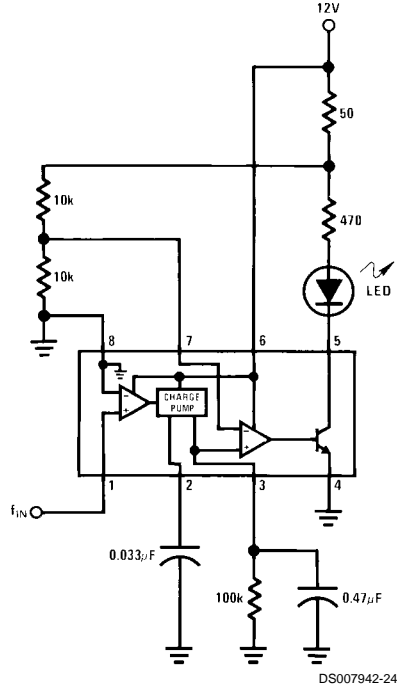

Typical Applications (Continued)

Changing the Output Voltage for an Input Frequency of Zero

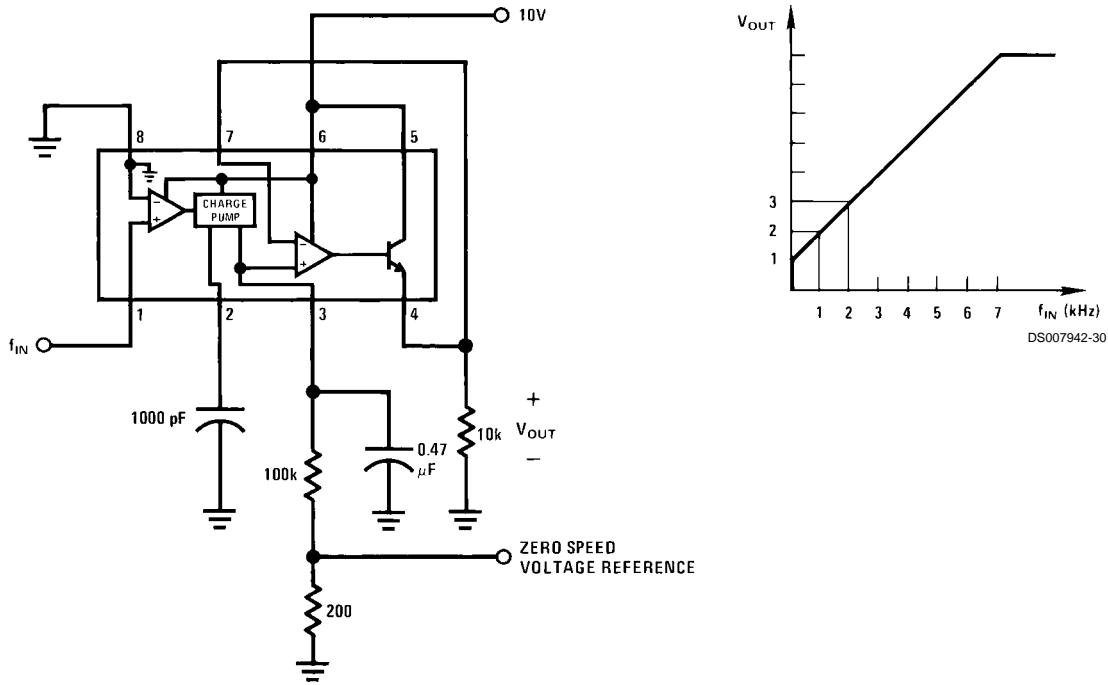

Changing Tachometer Gain Curve or Clamping the Minimum Output Voltage

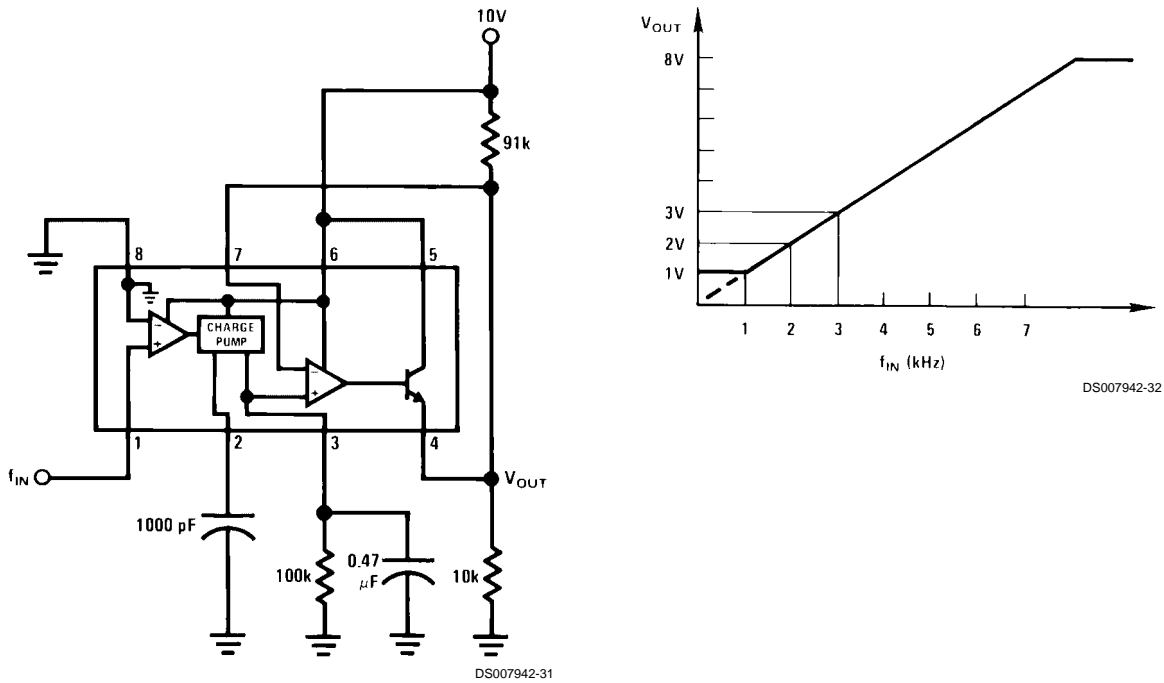

Anti-Skid Circuit Functions

“Select-Low” Circuit

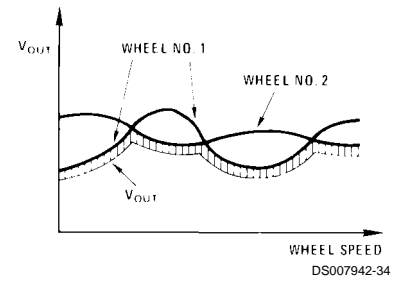
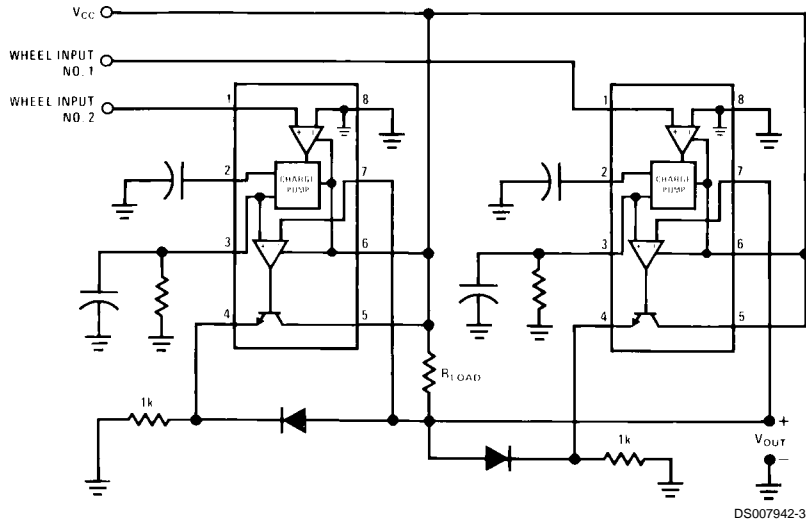

V_{OUT} is proportional to the lower of the two input wheel speeds.

“Select-High” Circuit

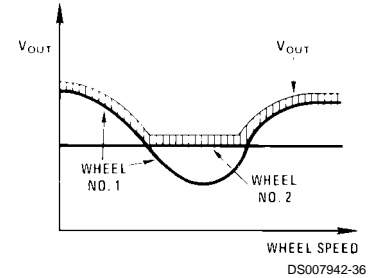
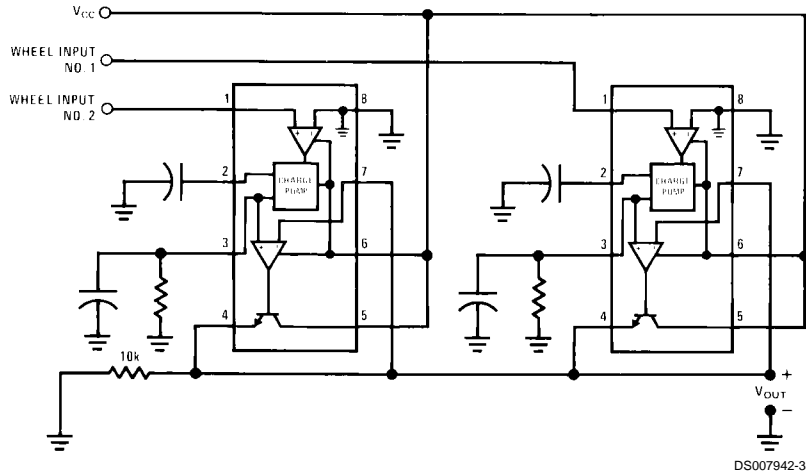

V_{OUT} is proportional to the higher of the two input wheel speeds.

“Select-Average” Circuit

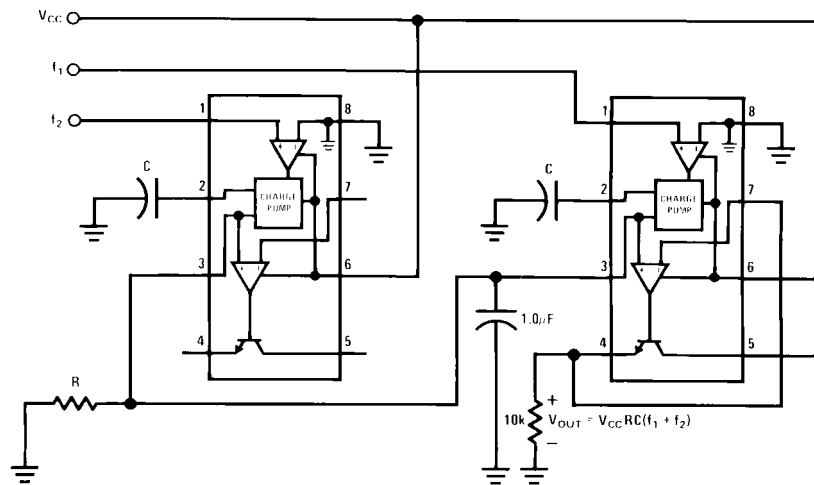

$V_{OUT} = V_{CC}RC(I_1 + I_2)$

Equivalent Schematic Diagram

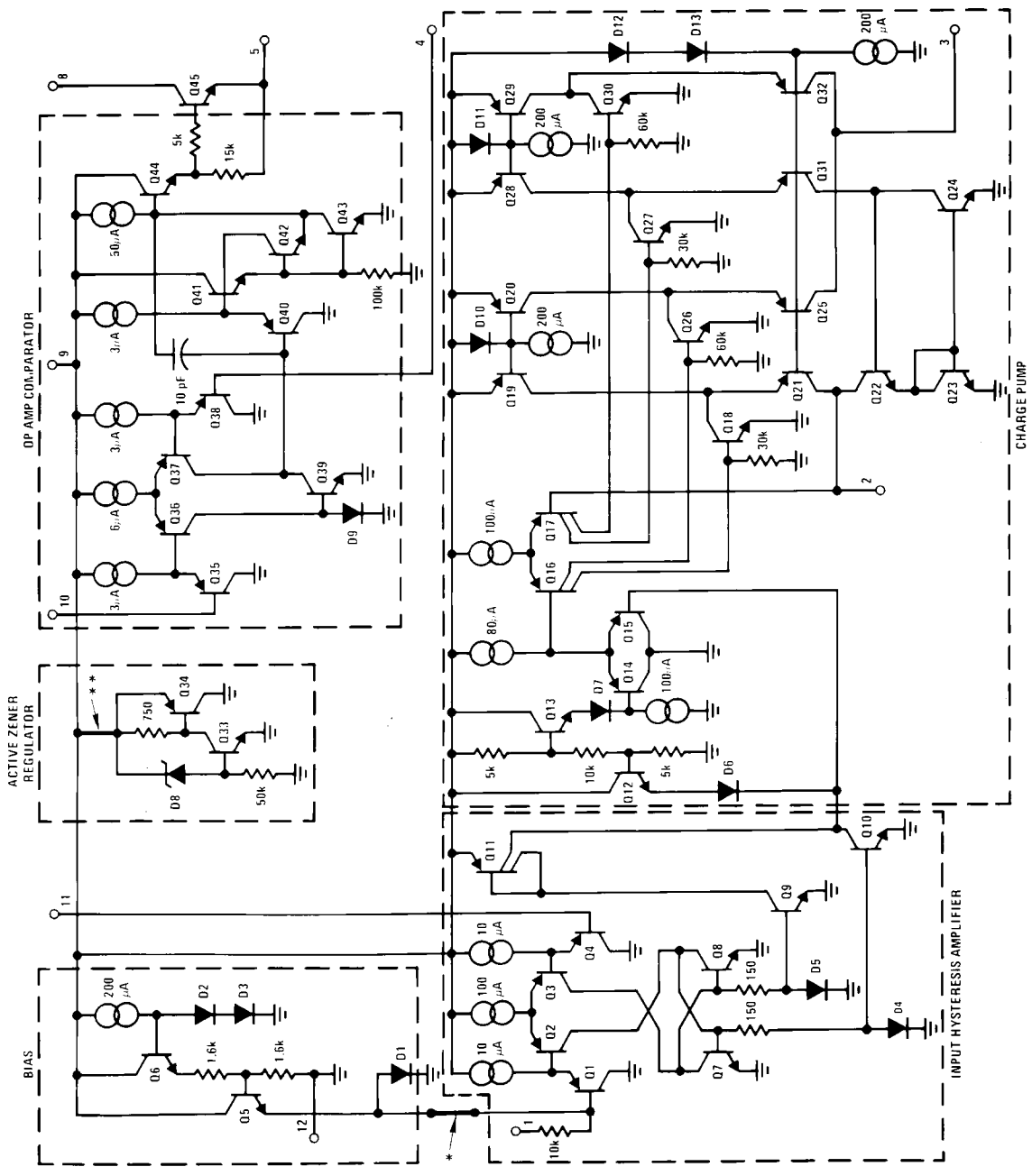

DS007942-38

*This connection made on LM2907-8 and LM2917-8 only.
 **This connection made on LM2917 and LM2917-8 only.

Physical Dimensions inches (millimeters) unless otherwise noted

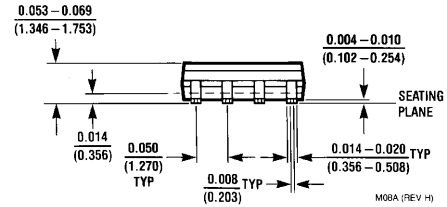
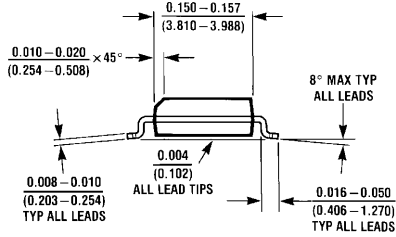
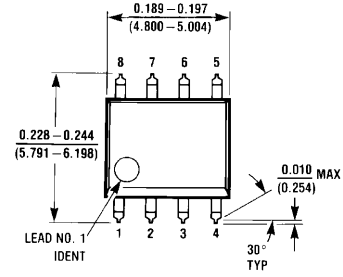

8-Lead (0.150" Wide) Molded Small Outline Package, JEDEC
Order Number LM2907M-8 or LM2917M-8
NS Package Number M08A

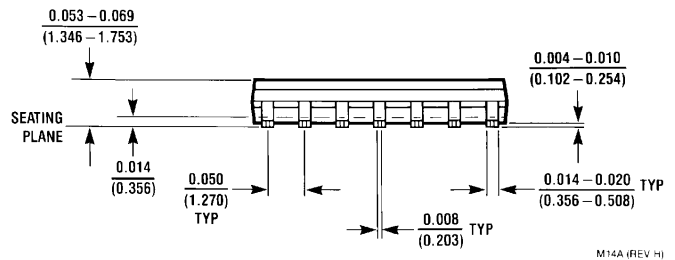
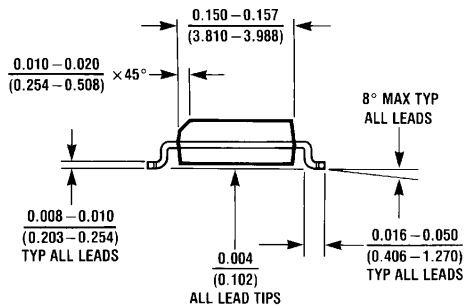
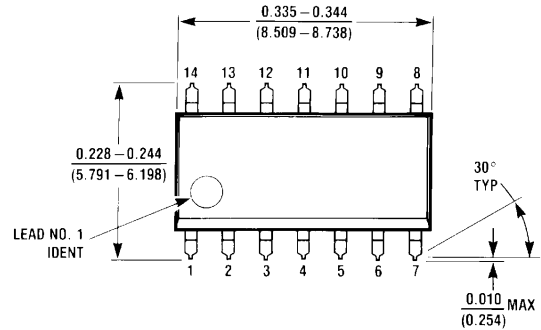

Molded SO Package (M)
Order Number LM2907M or LM2917M
NS Package Number M14A

Physical Dimensions inches (millimeters) unless otherwise noted (Continued)

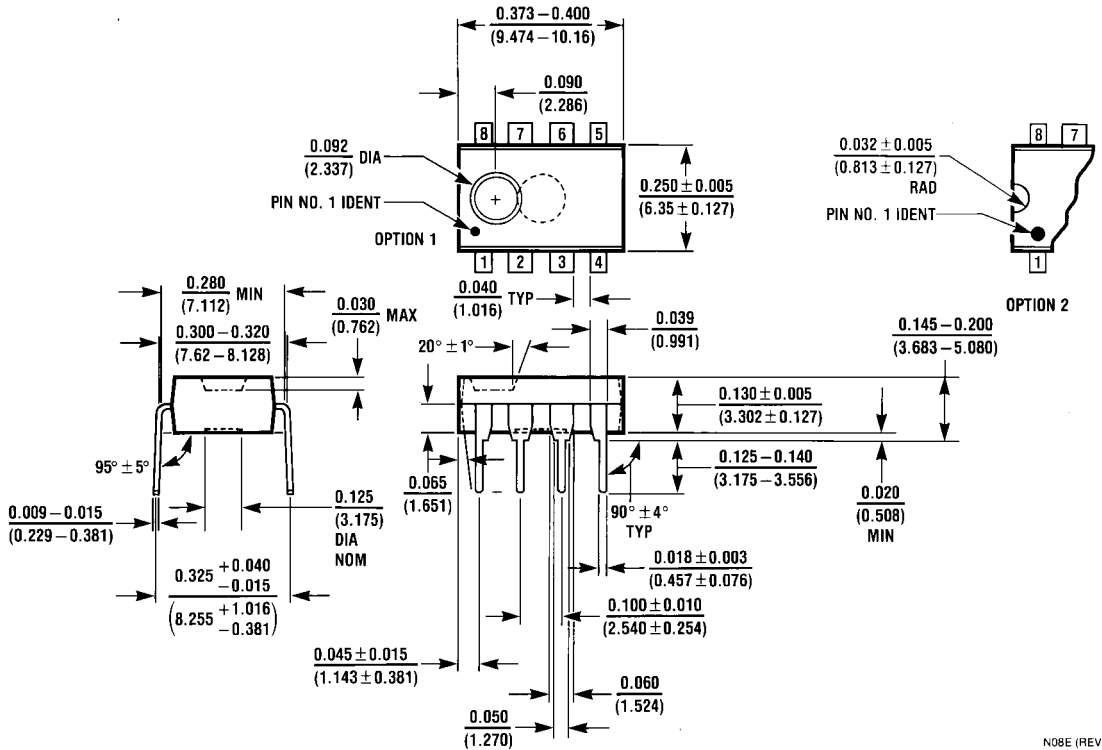

Molded Dual-In-Line Package (N)
Order Number LM2907N-8 or LM2917N-8
NS Package Number N08E

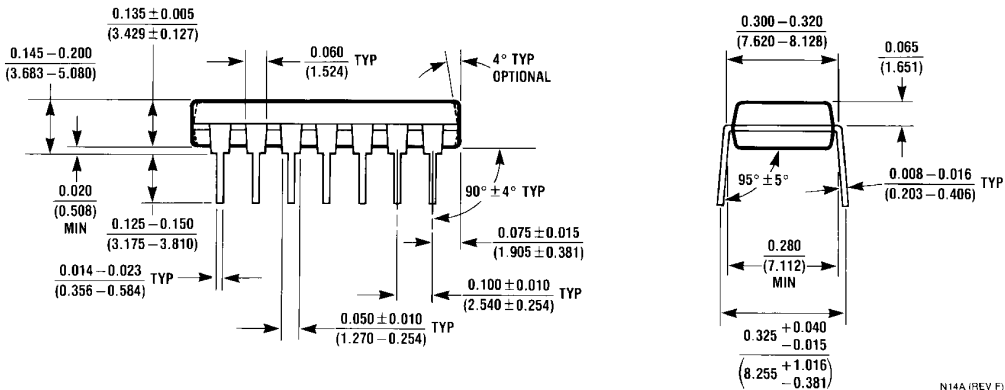
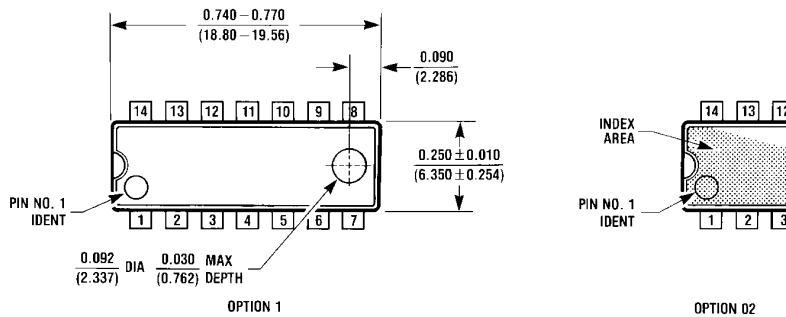

Molded Dual-In-Line Package (N)
Order Number LM2907N or LM2917N
NS Package Number N14A