



LM358W-LM358AW

Low Power Dual Operational Amplifiers

- Internally frequency compensated
- Large DC voltage gain: 100dB
- Wide bandwidth (unity gain): 1.1MHz (temperature compensated)
- Very low supply current/op (500 μ A) essentially independent of supply voltage
- Low input bias current: 20nA (temperature compensated)
- Low input offset voltage: 2mV
- Low input offset current: 2nA
- Input common-mode voltage range includes ground
- Differential input voltage range equal to the power supply voltage
- Large output voltage swing 0V to ($V_{CC} - 1.5V$)
- ESD internal protection: 1.5kV

Description

These circuits consist of two independent, high-gain, internally frequency-compensated which were designed specifically to operate from a single power supply over a wide range of voltages. The low power supply drain is independent of the magnitude of the power supply voltage.

Application areas include transducer amplifiers, DC gain blocks and all the conventional op-amp circuits which now can be more easily implemented in single power supply systems. For example, these circuits can be directly supplied with the standard +5V which is used in logic systems and will easily provide the required interface electronics without requiring any additional power supply.

In the linear mode the input common-mode voltage range includes ground and the output voltage can also swing to ground, even though operated from only a single power supply voltage.

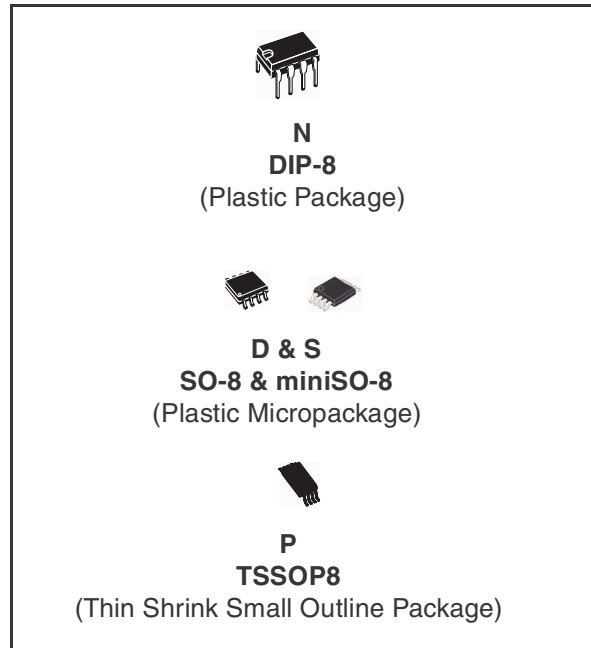

Pin Connections (top view)

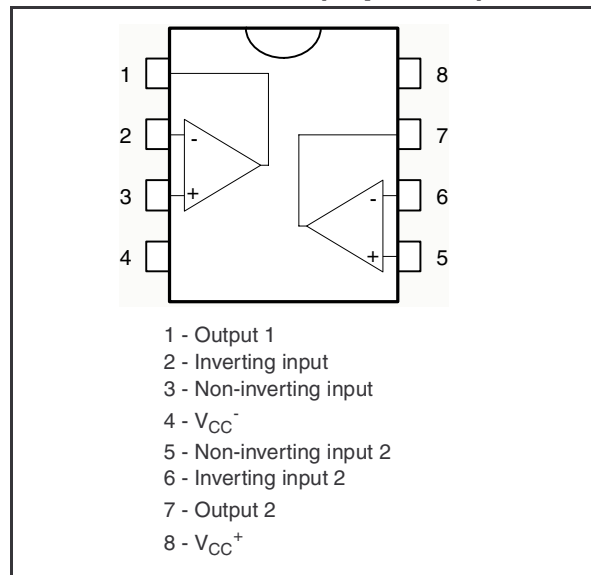

Order Codes

Part Number	Temperature Range	Package	Packaging	Marking
LM358WN	0°C, +70°C	DIP-8	Tube	LM358WN
LM358WD		SO-8	Tube or Tape & Reel	358W
LM358WDT				358AW
LM358AWD				
LM358AWDT				

1 Absolute Maximum Ratings

Table 1. Key parameters and their absolute maximum ratings

Symbol	Parameter	LM158W,AW	LM258W,AW	LM358W,AW	Unit
V_{CC}	Supply voltage	+32			V
V_i	Input Voltage	-0.3 to +32			V
V_{id}	Differential Input Voltage	+32			V
P_{tot}	Power Dissipation ⁽¹⁾	500			mW
	Output Short-circuit Duration ⁽²⁾	Infinite			
I_{in}	Input Current ⁽³⁾	50			mA
T_{oper}	Operating Free-air Temperature Range	-55 to +125	-40 to +105	0 to +70	°C
T_{stg}	Storage Temperature Range	-65 to +150			°C
ESD	HBM: Human Body Model ⁽⁴⁾	1.5			kV
	MM: Machine Model ⁽⁵⁾	200			V
	CDM: Charged Device Model	1.5			kV

1. Power dissipation must be considered to ensure maximum junction temperature (T_j) is not exceeded.
2. Short-circuits from the output to V_{CC} can cause excessive heating if $V_{CC} > 15V$. The maximum output current is approximately 40mA independent of the magnitude of V_{CC} . Destructive dissipation can result from simultaneous short-circuit on all amplifiers.
3. This input current only exists when the voltage at any of the input leads is driven negative. It is due to the collector-base junction of the input PNP transistor becoming forward biased and thereby acting as input diodes clamps. In addition to this diode action, there is also NPN parasitic action on the IC chip. this transistor action can cause the output voltages of the Op-amps to go to the V_{CC} voltage level (or to ground for a large overdrive) for the time duration than an input is driven negative. This is not destructive and normal output will set up again for input voltage higher than -0.3V.
4. Human body model, 100pF discharged through a 1.5k Ω resistor into pin of device.
5. Machine model ESD, a 200pF cap is charged to the specified voltage, then discharged directly into the IC with no external series resistor (internal resistor < 5 Ω), into pin to pin of device.

2 Typical Application Schematic

Figure 1. Schematic diagram (1/2 LM158W)

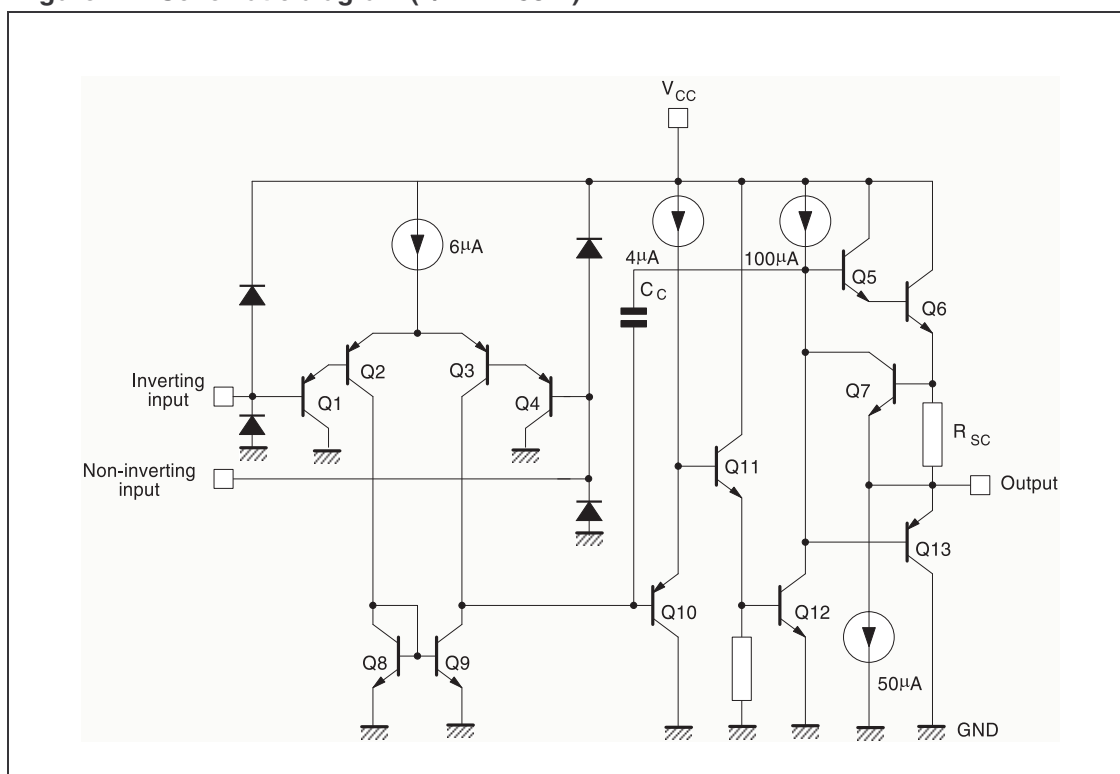

3 Electrical Characteristics

Table 2. $V_{CC}^+ = +5V$, $V_{CC}^- = \text{Ground}$, $V_o = 1.4V$, $T_{amb} = +25^\circ C$ (unless otherwise specified)

Symbol	Parameter	LM158AW-LM258AW LM358AW			LM158W-LM258W LM358W			Unit
		Min.	Typ.	Max.	Min.	Typ.	Max.	
V_{io}	Input Offset Voltage - note ⁽¹⁾ $T_{amb} = +25^\circ C$ LM158, LM258 LM158A $T_{min} \leq T_{amb} \leq T_{max}$ LM158, LM258		1	3		2	7 5	mV
I_{io}	Input Offset Current $T_{amb} = +25^\circ C$ $T_{min} \leq T_{amb} \leq T_{max}$		2	10 30		2	30 40	nA
I_{ib}	Input Bias Current - note ⁽²⁾ $T_{amb} = +25^\circ C$ $T_{min} \leq T_{amb} \leq T_{max}$		20	50 100		20	150 200	nA
A_{vd}	Large Signal Voltage Gain $V_{CC} = +15V$, $R_L = 2k\Omega$, $V_o = 1.4V$ to $11.4V$ $T_{amb} = +25^\circ C$ $T_{min} \leq T_{amb} \leq T_{max}$	50 25	100		50 25	100		V/ mV
SVR	Supply Voltage Rejection Ratio ($R_s \leq 10k\Omega$) $V_{CC}^+ = 5V$ to $30V$ $T_{amb} = +25^\circ C$ $T_{min} \leq T_{amb} \leq T_{max}$	65 65	100		65 65	100		dB
I_{CC}	Supply Current, all Amp, no load $T_{min} \leq T_{amb} \leq T_{max}$, $V_{CC} = +5V$ $T_{min} \leq T_{amb} \leq T_{max}$, $V_{CC} = +30V$		0.7	1.2 1		0.7	1.2 2	mA
V_{icm}	Input Common Mode Voltage Range $V_{CC} = +30V$ - note ⁽³⁾ $T_{amb} = +25^\circ C$ $T_{min} \leq T_{amb} \leq T_{max}$	0 0		$V_{CC}^+ - 1.5$ $V_{CC}^+ - 2$	0 0		$V_{CC}^+ - 1.5$ $V_{CC}^+ - 2$	V
CMR	Common Mode Rejection Ratio ($R_s \leq 10k\Omega$) $T_{amb} = +25^\circ C$ $T_{min} \leq T_{amb} \leq T_{max}$	70 60	85		70 60	85		dB
I_{source}	Output Current Source $V_{CC} = +15V$, $V_o = +2V$, $V_{id} = +1V$	20	40	60	20	40	60	mA
I_{sink}	Output Sink Current ($V_{id} = -1V$) $V_{CC} = +15V$, $V_o = +2V$ $V_{CC} = +15V$, $V_o = +0.2V$	10 12	20 50		10 12	20 50		mA μA

Table 2. $V_{CC}^+ = +5V$, $V_{CC}^- = \text{Ground}$, $V_o = 1.4V$, $T_{amb} = +25^\circ\text{C}$ (unless otherwise specified)

Symbol	Parameter	LM158AW-LM258AW LM358AW			LM158W-LM258W LM358W			Unit
		Min.	Typ.	Max.	Min.	Typ.	Max.	
V_{OPP}	Output Voltage Swing ($R_L = 2k\Omega$) $T_{amb} = +25^\circ\text{C}$ $T_{min} \leq T_{amb} \leq T_{max}$	0 0		$V_{CC}^+ - 1.5$ $V_{CC}^+ - 2$	0 0		$V_{CC}^+ - 1.5$ $V_{CC}^+ - 2$	
V_{OH}	High Level Output Voltage ($V_{CC}^+ = 30V$) $T_{amb} = +25^\circ\text{C}$, $R_L = 2k\Omega$ $T_{min} \leq T_{amb} \leq T_{max}$ $T_{amb} = +25^\circ\text{C}$, $R_L = 10k\Omega$ $T_{min} \leq T_{amb} \leq T_{max}$	26 26 27 27	27 28		26 26 27 27	27 28		V
V_{OL}	Low Level Output Voltage ($R_L = 10k\Omega$) $T_{amb} = +25^\circ\text{C}$ $T_{min} \leq T_{amb} \leq T_{max}$		5	20 20		5	20 20	mV
SR	Slew Rate $V_{CC} = 15V$, $V_i = 0.5$ to $3V$, $R_L = 2k\Omega$, $C_L = 100pF$, unity Gain	0.3	0.6		0.3	0.6		V/ μs
GBP	Gain Bandwidth Product $V_{CC} = 30V$, $f = 100kHz$, $V_{in} = 10mV$, $R_L = 2k\Omega$, $C_L = 100pF$	0.7	1.1		0.7	1.1		MHz
THD	Total Harmonic Distortion $f = 1kHz$, $A_v = 20dB$, $R_L = 2k\Omega$, $V_o = 2V_{pp}$, $C_L = 100pF$, $V_o = 2V_{pp}$		0.02			0.02		%
e_n	Equivalent Input Noise Voltage $f = 1kHz$, $R_s = 100\Omega$, $V_{CC} = 30V$		55			55		$\frac{nV}{\sqrt{Hz}}$
DV_{io}	Input Offset Voltage Drift		7	15		7	30	$\mu\text{V}/^\circ\text{C}$
DI_{lio}	Input Offset Current Drift		10	200		10	300	$pA/^\circ\text{C}$
V_{o1}/V_{o2}	Channel Separation - note (4) $1kHz \leq f \leq 20kHz$		120			120		dB

- $V_o = 1.4V$, $R_s = 0\Omega$, $5V < V_{CC}^+ < 30V$, $0 < V_{ic} < V_{CC}^+ - 1.5V$
- The direction of the input current is out of the IC. This current is essentially constant, independent of the state of the output so no loading change exists on the input lines.
- The input common-mode voltage of either input signal voltage should not be allowed to go negative by more than 0.3V. The upper end of the common-mode voltage range is $V_{CC}^+ - 1.5V$, but either or both inputs can go to +32V without damage.
- Due to the proximity of external components insure that coupling is not originating via stray capacitance between these external parts. This typically can be detected as this type of capacitance increases at higher frequencies.

Figure 2. Open loop frequency response

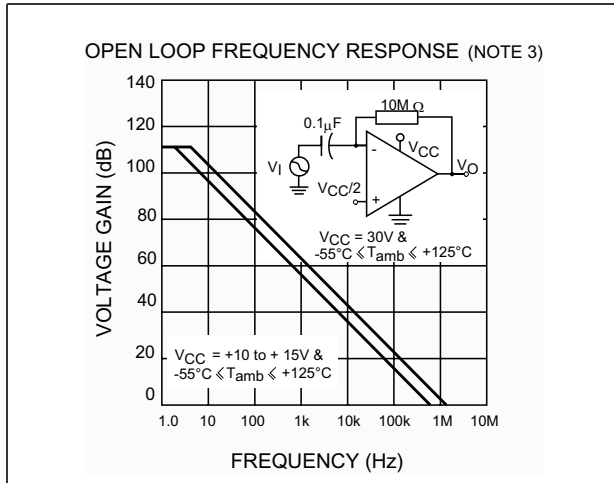

Figure 3. Large signal frequency response

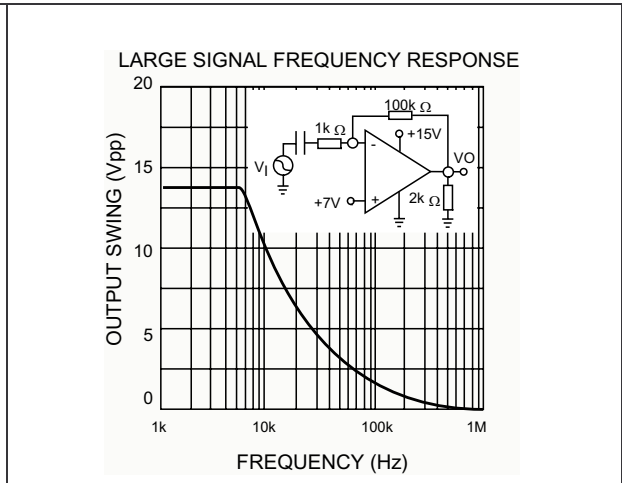

Figure 4. Voltage follower pulse response

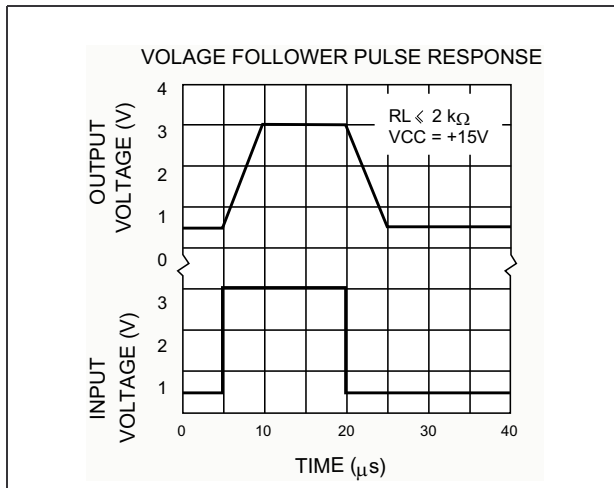

Figure 5. Voltage follower pulse response

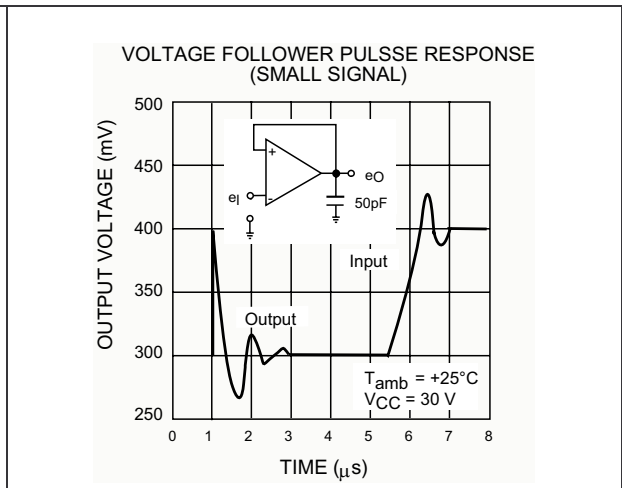

Figure 6. Input current

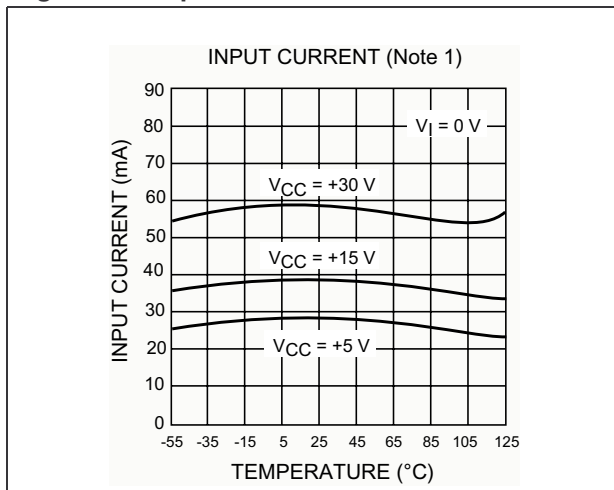

Figure 7. Output characteristics

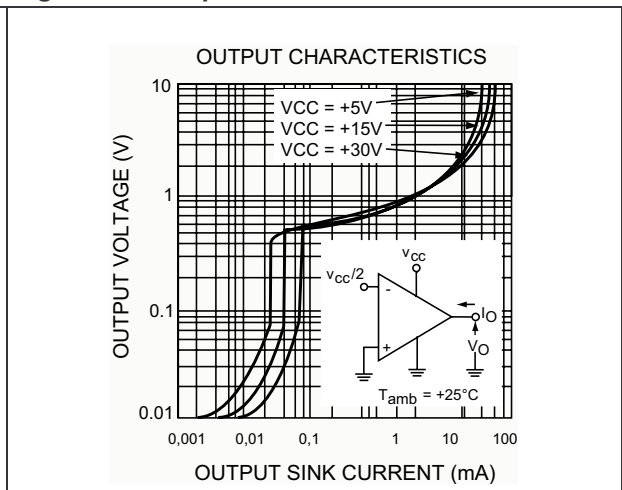

Figure 8. Output characteristics

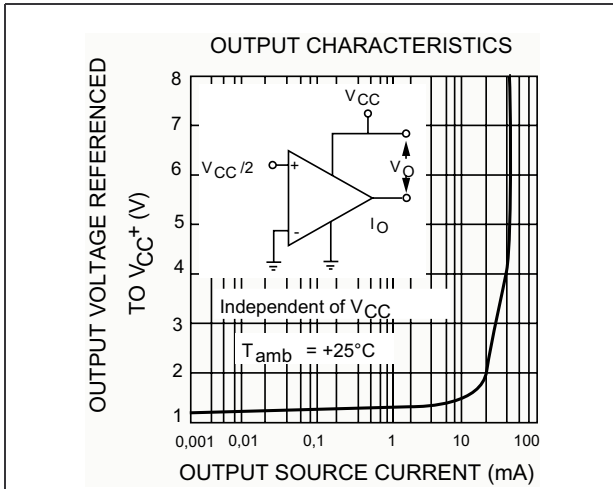

Figure 9. Current limiting

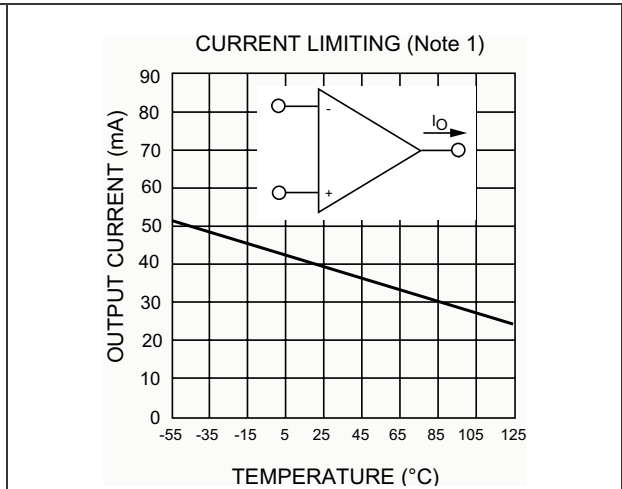

Figure 10. Input voltage range

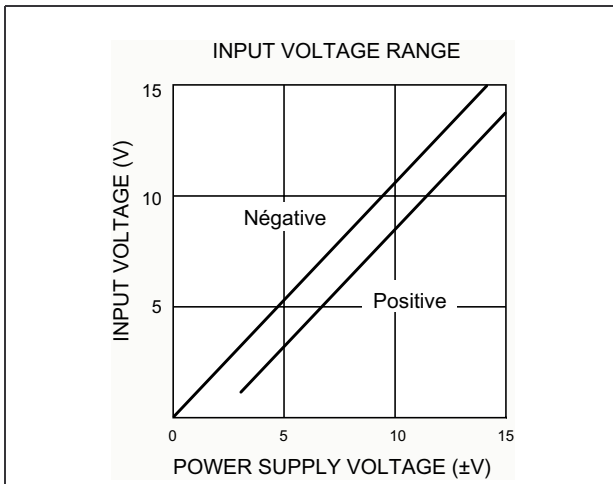

Figure 11. Positive supply voltage

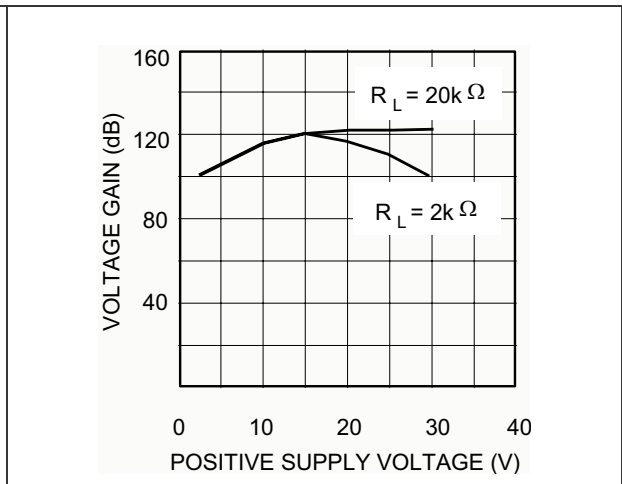

Figure 12. Input voltage range

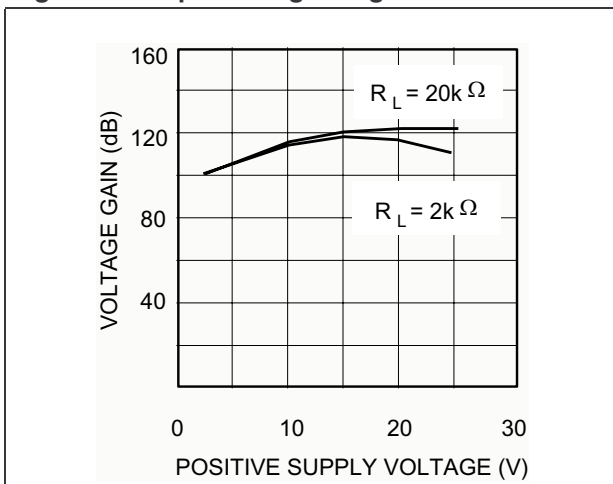

Figure 13. Supply current

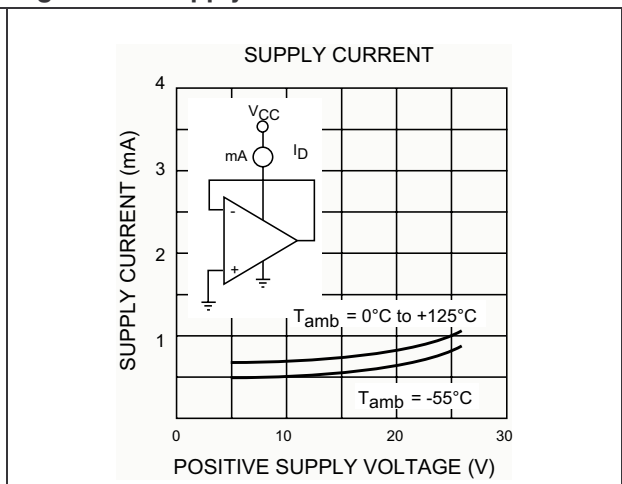

Figure 14. Input current

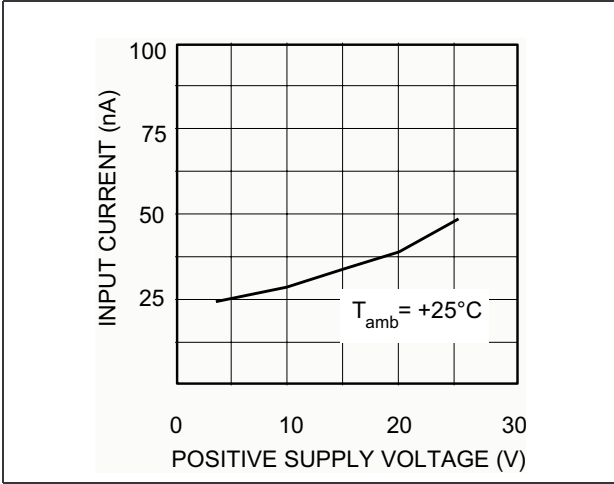

Figure 15. Gain bandwidth product

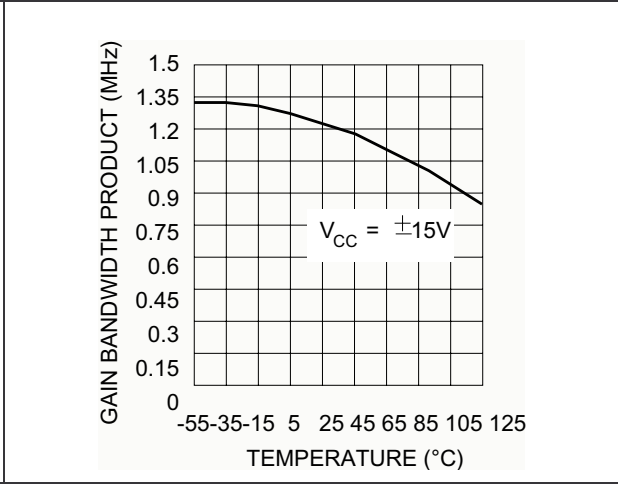

Figure 16. Power supply rejection ratio

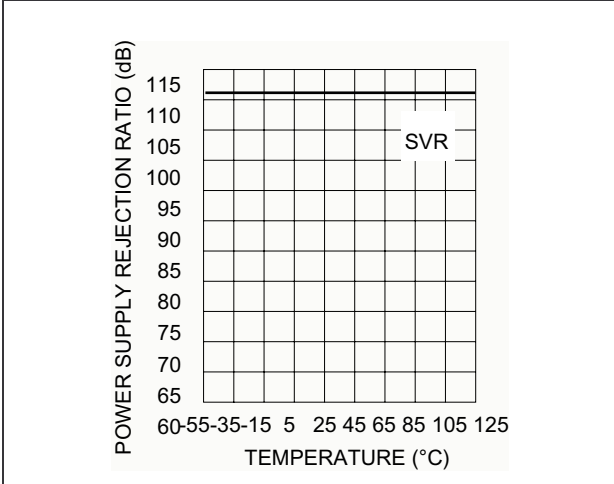
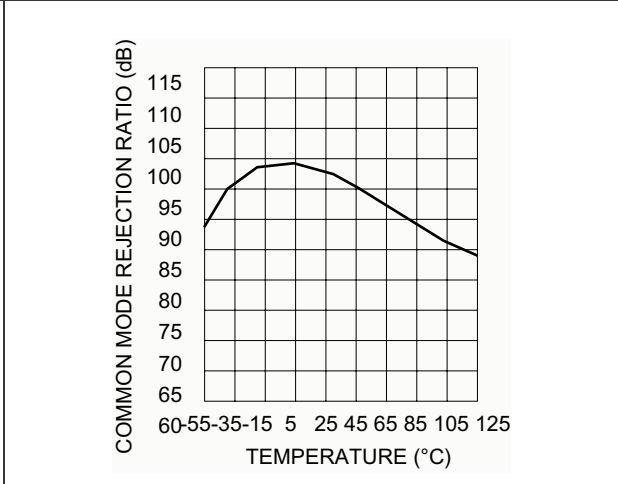

Figure 17. Common mode rejection ratio



4 Typical Applications

(single supply voltage) $V_{CC} = +5V_{dc}$

Figure 18. AC coupled inverting amplifier

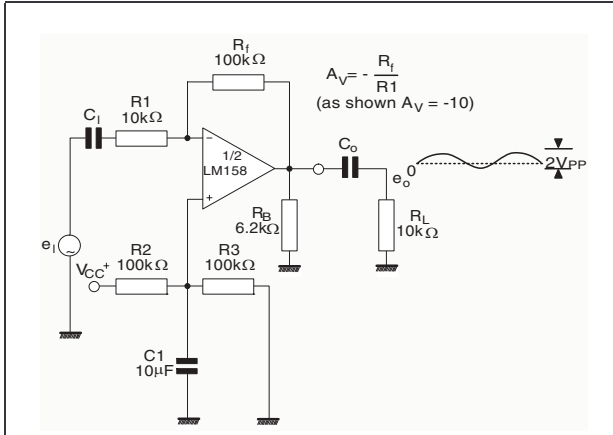

Figure 19. Non-inverting DC amplifier

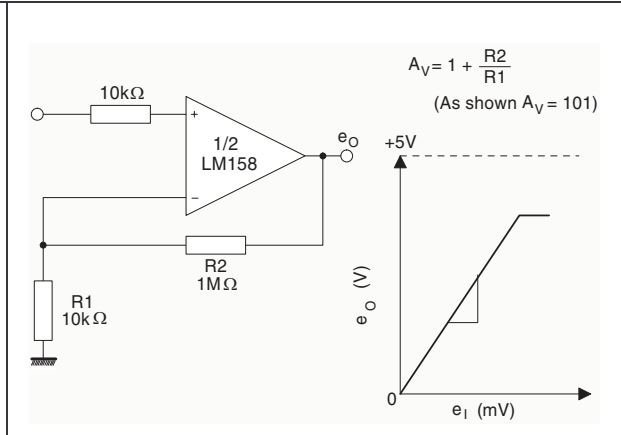

Figure 20. AC coupled non-inverting amplifier

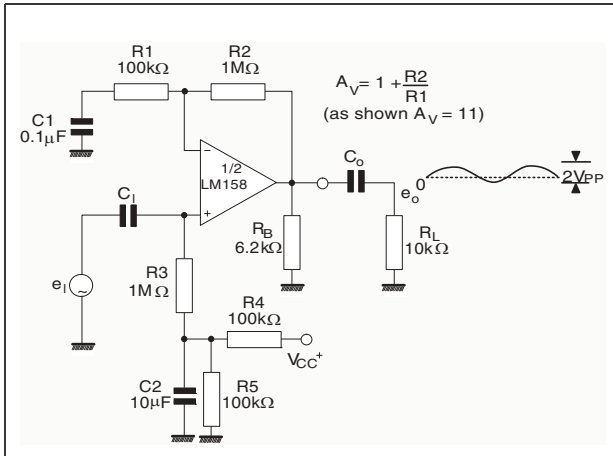

Figure 21. DC summing amplifier

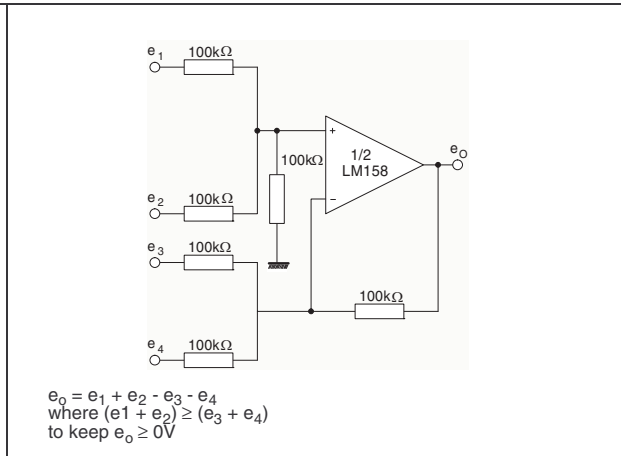

Figure 22. High input Z, DC differential amplifier

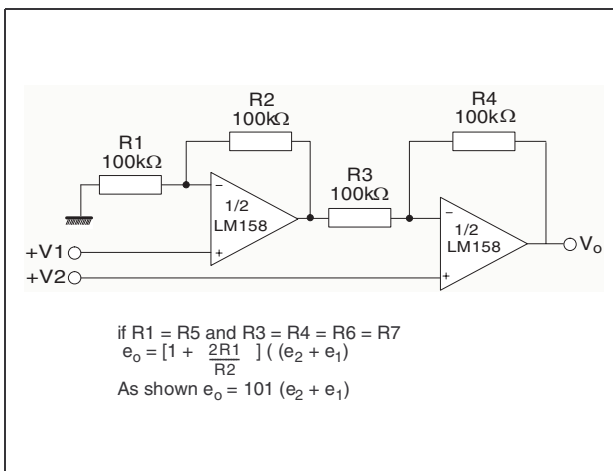

Figure 23. High input Z adjustable gain DC instrumentation amplifier

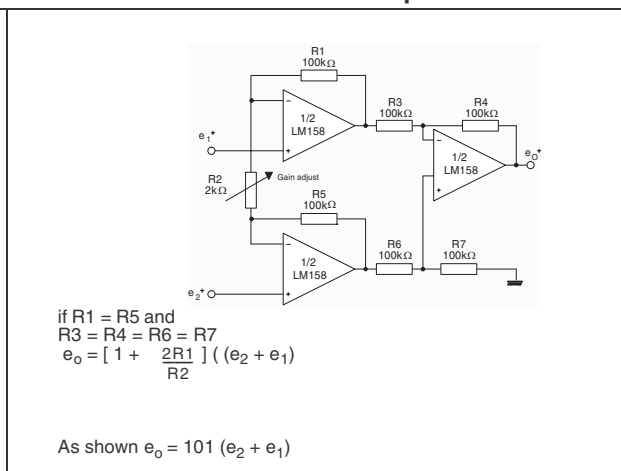

Figure 24. Using symmetrical amplifiers to reduce input current

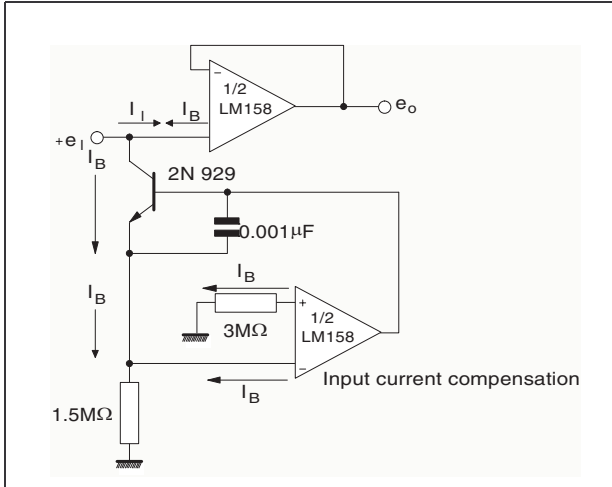

Figure 25. Low drift peak detector

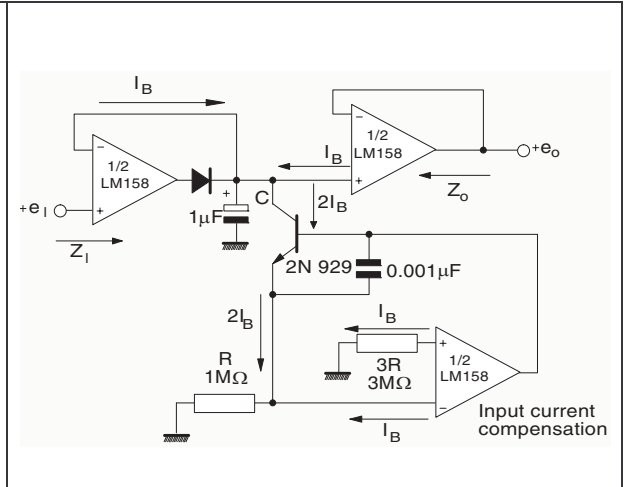
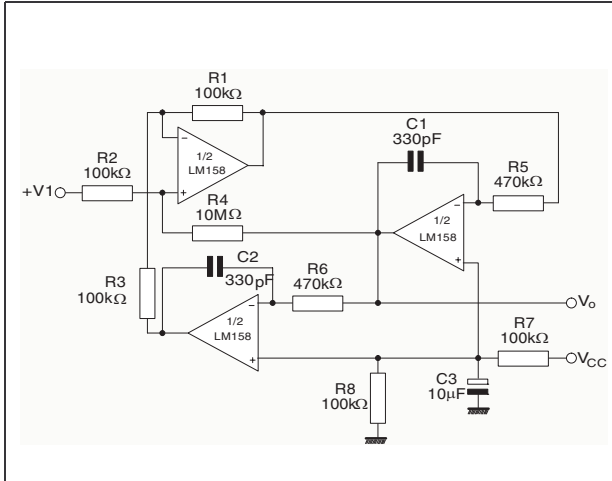

Figure 26. Active band-pass filter



5 Package Mechanical Data

In order to meet environmental requirements, ST offers these devices in ECOPACK[®] packages. These packages have a Lead-free second level interconnect. The category of second level interconnect is marked on the package and on the inner box label, in compliance with JEDEC Standard JESD97. The maximum ratings related to soldering conditions are also marked on the inner box label. ECOPACK is an ST trademark. ECOPACK specifications are available at: www.st.com.

5.1 DIP8 Package

Plastic DIP-8 MECHANICAL DATA

DIM.	mm.			inch		
	MIN.	TYP.	MAX.	MIN.	TYP.	MAX.
A		3.3			0.130	
a1	0.7			0.028		
B	1.39		1.65	0.055		0.065
B1	0.91		1.04	0.036		0.041
b		0.5			0.020	
b1	0.38		0.5	0.015		0.020
D			9.8			0.386
E		8.8			0.346	
e		2.54			0.100	
e3		7.62			0.300	
e4		7.62			0.300	
F			7.1			0.280
I			4.8			0.189
L		3.3			0.130	
Z	0.44		1.6	0.017		0.063

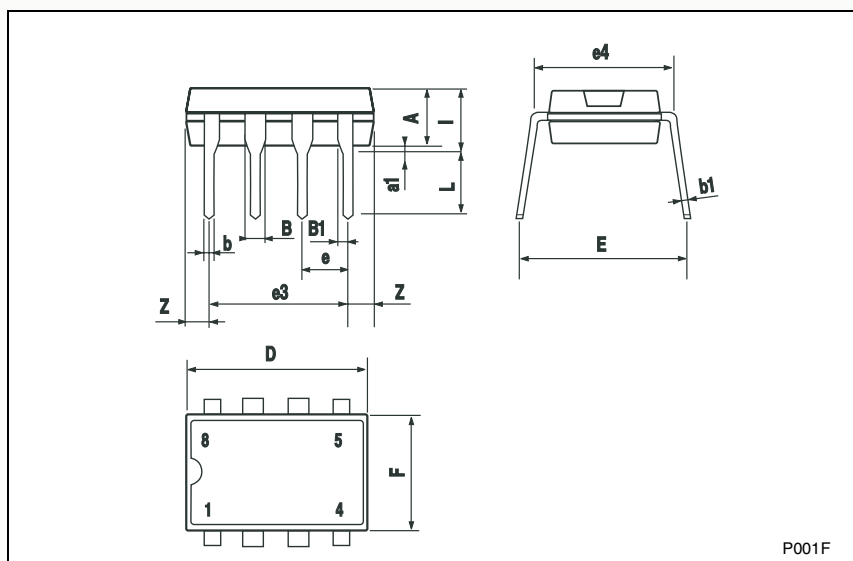

P001F

5.2 SO-8 Package

SO-8 MECHANICAL DATA

DIM.	mm.			inch		
	MIN.	TYP.	MAX.	MIN.	TYP.	MAX.
A	1.35		1.75	0.053		0.069
A1	0.10		0.25	0.04		0.010
A2	1.10		1.65	0.043		0.065
B	0.33		0.51	0.013		0.020
C	0.19		0.25	0.007		0.010
D	4.80		5.00	0.189		0.197
E	3.80		4.00	0.150		0.157
e		1.27			0.050	
H	5.80		6.20	0.228		0.244
h	0.25		0.50	0.010		0.020
L	0.40		1.27	0.016		0.050
k	8° (max.)					
ddd			0.1			0.04

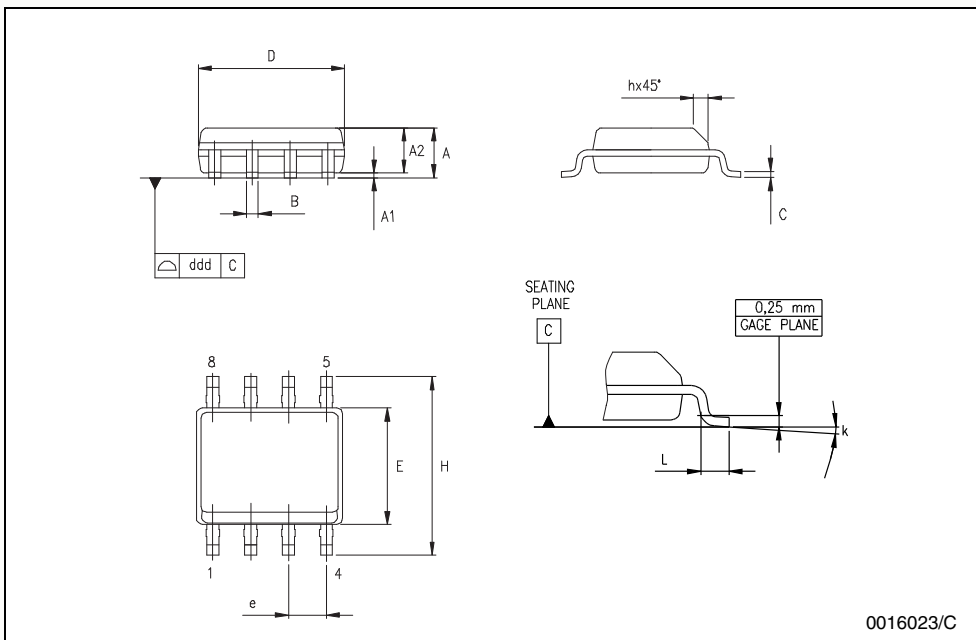

5.3 MiniSO-8 Package

miniSO-8 MECHANICAL DATA

DIM.	mm.			inch		
	MIN.	TYP	MAX.	MIN.	TYP.	MAX.
A			1.1			0.043
A1	0.05	0.10	0.15	0.002	0.004	0.006
A2	0.78	0.86	0.94	0.031	0.031	0.037
b	0.25	0.33	0.40	0.010	0.13	0.013
c	0.13	0.18	0.23	0.005	0.007	0.009
D	2.90	3.00	3.10	0.114	0.118	0.122
E	4.75	4.90	5.05	0.187	0.193	0.199
E1	2.90	3.00	3.10	.0114	0.118	0.122
e		0.65			0.026	
K	0°		6°	0°		6°
L	0.40	0.55	0.70	0.016	0.022	0.028
L1			0.10			0.004

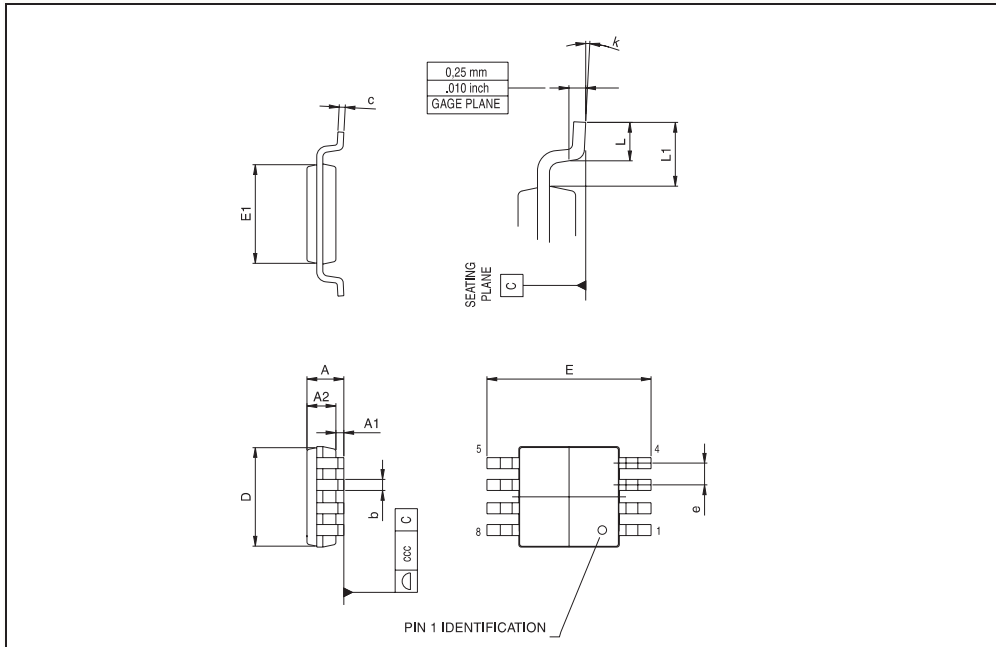

5.4 TSSOP8 Package

TSSOP8 MECHANICAL DATA

DIM.	mm.			inch		
	MIN.	TYP	MAX.	MIN.	TYP.	MAX.
A			1.2			0.047
A1	0.05		0.15	0.002		0.006
A2	0.80	1.00	1.05	0.031	0.039	0.041
b	0.19		0.30	0.007		0.012
c	0.09		0.20	0.004		0.008
D	2.90	3.00	3.10	0.114	0.118	0.122
E	6.20	6.40	6.60	0.244	0.252	0.260
E1	4.30	4.40	4.50	0.169	0.173	0.177
e		0.65			0.0256	
K	0°		8°	0°		8°
L	0.45	0.60	0.75	0.018	0.024	0.030
L1		1			0.039	

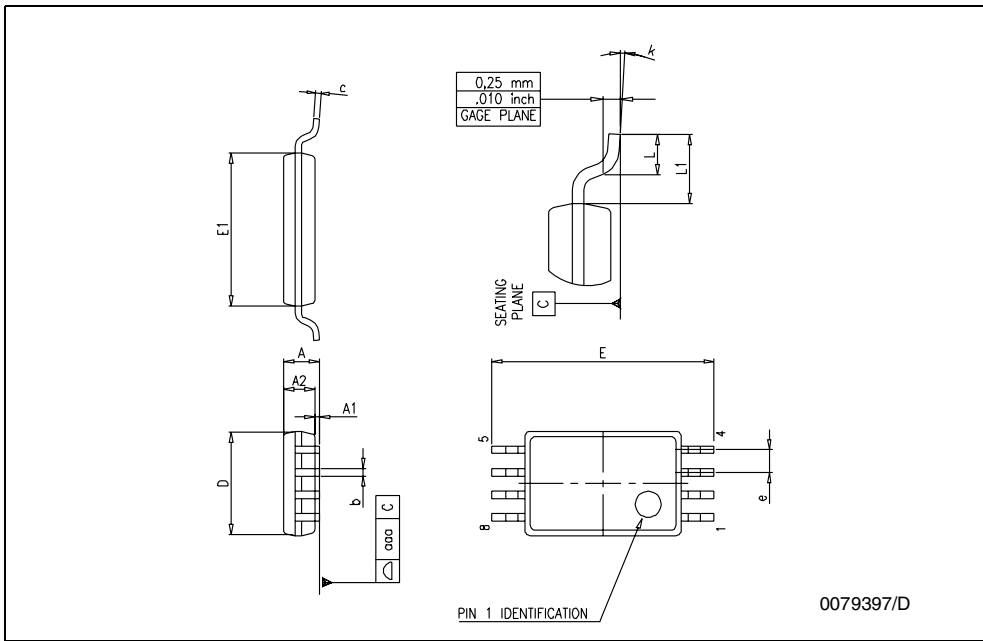

6 Revision History

Date	Revision	Changes
Nov. 2002	1	First Release
July 2005	3	ESD protection inserted in <i>Table 1 on page 3</i>

Information furnished is believed to be accurate and reliable. However, STMicroelectronics assumes no responsibility for the consequences of use of such information nor for any infringement of patents or other rights of third parties which may result from its use. No license is granted by implication or otherwise under any patent or patent rights of STMicroelectronics. Specifications mentioned in this publication are subject to change without notice. This publication supersedes and replaces all information previously supplied. STMicroelectronics products are not authorized for use as critical components in life support devices or systems without express written approval of STMicroelectronics.

The ST logo is a registered trademark of STMicroelectronics.
All other names are the property of their respective owners

© 2005 STMicroelectronics - All rights reserved

STMicroelectronics group of companies

Australia - Belgium - Brazil - Canada - China - Czech Republic - Finland - France - Germany - Hong Kong - India - Israel - Italy - Japan - Malaysia - Malta - Morocco - Singapore - Spain - Sweden - Switzerland - United Kingdom - United States of America

www.st.com

Copyright © Each Manufacturing Company.

All Datasheets cannot be modified without permission.

This datasheet has been download from :

www.AllDataSheet.com

100% Free DataSheet Search Site.

Free Download.

No Register.

Fast Search System.

www.AllDataSheet.com