

SPECIFICATION FOR COTCO LED LAMP

MODEL : LP377THR1-70G
REF. : A 01B07

DESCRIPTIONS:

70 DEGREE 7.6×7.6MM LED
LAMP IN HIGH RED COLOR
WITH WATER TRANSPARENT
LENS AND STOPPER



COTCO LUMINANT DEVICE (HUIZHOU) LTD.

DOC. NO. :	SPE/LP377THR1-70G
REF:	A 01B07

DIMENSION DRAWING

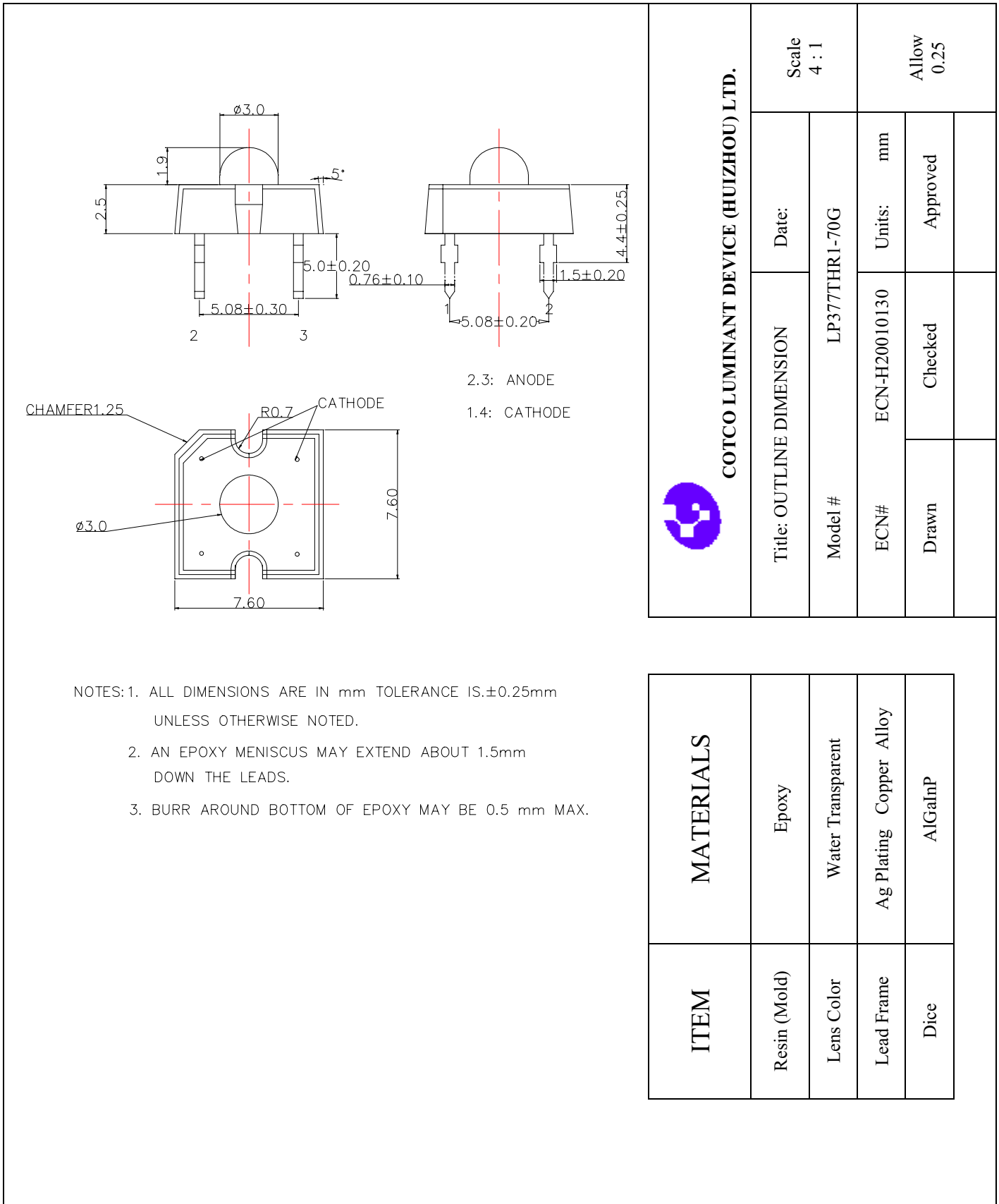

- NOTES: 1. ALL DIMENSIONS ARE IN mm TOLERANCE IS ± 0.25 mm UNLESS OTHERWISE NOTED.
2. AN EPOXY MENISCUS MAY EXTEND ABOUT 1.5mm DOWN THE LEADS.
3. BURR AROUND BOTTOM OF EPOXY MAY BE 0.5 mm MAX.

 **COTCO LUMINANT DEVICE (HUIZHOU) LTD.**

Title: OUTLINE DIMENSION	Date:	Scale 4 : 1	Units: mm	Allow 0.25
	Model #	LP377THR1-70G		
ECN#	ECN-H20010130	Checked	Approved	
Drawn				

ITEM	MATERIALS
Resin (Mold)	Epoxy
Lens Color	Water Transparent
Lead Frame	Ag Plating Copper Alloy
Dice	AlGaInP

DOC. NO. :	SPE/LP377THR1-70G
REF:	A 01B07

These specification shall be applied to the LED model # LP377THR1-70G,
which is supplied by Cotco Luminant Device (HUIZHOU) Ltd.

SPECIFICATION

Absolute Maximum Rating (T_a = 25°C)

Items	Symbol	Absolute maximum Rating	Unit
Forward Current	I _F	70	mA
Peak Forward Current pulse width ≤ 0.1msec duty ≤ 1/10	I _{FP}	200	mA
Reverse Voltage	V _R	5	V
Power Dissipation	P _D	150	mW
Operation Temperature	T _{opr}	-40 ~ +100	°C
Storage Temperature	T _{stg}	-40 ~ +100	°C
Lead Soldering Temperature	T _{sol}	260°C for 5sec (3mm from the base of the epoxy bulb)	

Initial Electrical/Optical Characteristics (T_a = 25°C)

Items	Symbol	Condition	Min.	Typ.	Max.	Unit
Forward Voltage	V _F	I _F = 70mA	2.2	2.6	3.0	V
Reverse Current	I _R	V _R = 5V	---	---	100	μA
Wavelength	λ _D	I _F = 70mA	625	628	635	nm
Luminous Flux	Φ _V	I _F = 70mA	2200	4000	---	mlm
50% Power Angle	2θ _½	I _F = 70mA	---	70	---	deg

Luminous Flux Combination *

Rank	R	S	T
Luminous Flux (I _f =70mA)	2200-3000 mlm	3000-4180 mlm	4180-5860 mlm

One normal delivery will include all ranks listed above.

The quantity ratio of the ranks is decided by COTCO.

Measurement Uncertainty of the Luminous flux : ±15%

*Φ_V test condition: I_f=70mA.

DOC. NO. :	SPE/LP377THR1-70G
REF:	A 01B07

RELIABILITY

Test Items And Results

Type	Test Item	REF. Standard	Test Condition	Note	Number of Damaged
Environmental Sequence	Temperature Cycle	JIS C 7021 (1977)A-4	-40°C ⇒ 25°C ⇒ 100°C ⇒ 25°C 30mins, 5mins, 30mins, 5mins	100 cycles	0 / 100
	Thermal Shock	MIL-STD-107D	-40°C ⇒ 100°C 15mins, 15mins	100 cycles	0 / 100
	High Humidity Heat Cycle	JIS C 7021 (1977)A-5	30°C ⇒ 65°C 90%RH 24hrs/1cycle	10 cycles	0 / 100
	High Temperature Storage	JIS C 7021 (1977)B-10	T _a = 100°C	1000hrs	0 / 100
	Humidity Heat Storage	JIS C 7021 (1977)B-11	T _a = 60°C RH = 90%	1000hrs	0 / 100
	Low Temperature Storage	JIS C 7021 (1977)B-12	T _a = -40°C	1000hrs	0 / 100
Operation Sequence	Life Test	JIS C 7035 (1985)	T _a = 25°C I _F = 70mA	1000hrs	0 / 100
	High Humidity Heat Life Test	*	60°C RH=90% I _F = 70mA	500hrs	0 / 100
	Low Temperature Life Test	*	T _a = -30°C I _F = 70mA	1000hrs	0 / 100
Destructive Sequence	Resistance to Soldering Heat	JIS C 7021 (1977)A-11	T _{sol} = 260±5°C , 10sec (3mm from the base of the epoxy bulb)	1 time	0 / 20
	Solderability	JIS C 7021 (1977)A-2	T _{sol} = 235±5°C , 5sec (using flux)	1 time (over 95%)	0 / 20
	Lead Pull/Bend Test	JIS C 7021 (1977)A-11	Load 2.5N (0.25kgf) 0° ⇒ 90° ⇒ 0° bend 3 times	No noticeable damage	0 / 20

*Refer to reliability test standard specification for in this line.

Criteria for Judging The Damage

Item	Symbol	Test Condition	Criteria for Judgment	
			Min.	Max.
Forward Voltage	V _F	I _F = 70mA	---	Initial Data × 1.2
Reverse Current	I _R	V _R = 5V	---	100μA
Luminous Flux	Φ _V	I _F = 70mA	Initial Data x 0.65 (Total degradation) Initial Data x 0.5 (single lamp degradation)	---
Dominant Wavelength	λ _D	I _F = 70mA	Initial Data ±2nm	

DOC. NO. :	SPE/LP377THR1-70G
REF:	A 01B07

GRAPHS

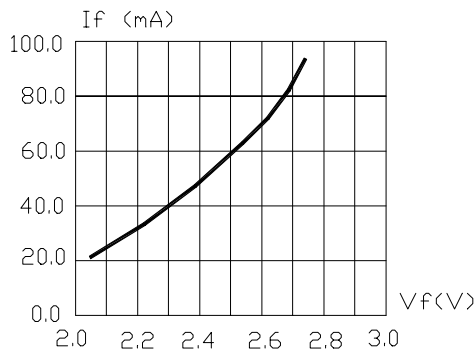

FIG.1 FORWARD CURRENT VS. FORWARD VOLTAGE.

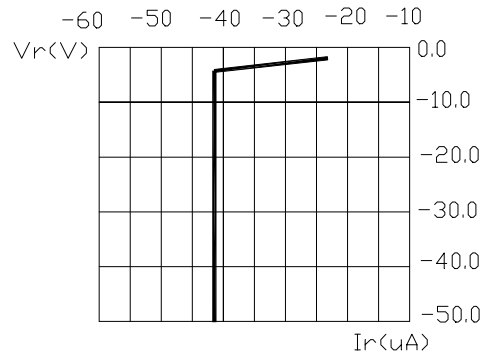

FIG.2 REVERSE CURRENT VS. REVERSE VOLTAGE.

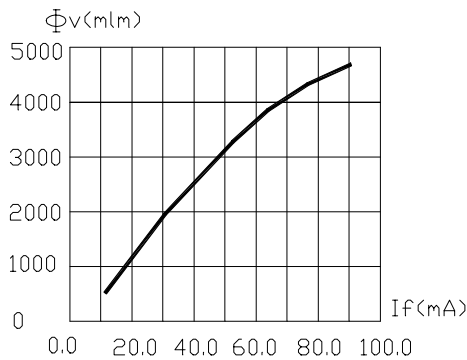

FIG.3 RELATIVE FLUX VS. FORWARD CURRENT.

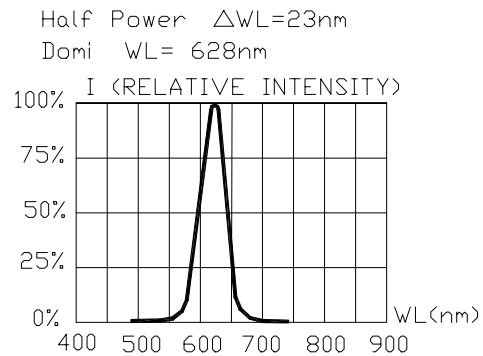

FIG.4 RELATIVE INTENSITY VS. WAVE LENGTH.

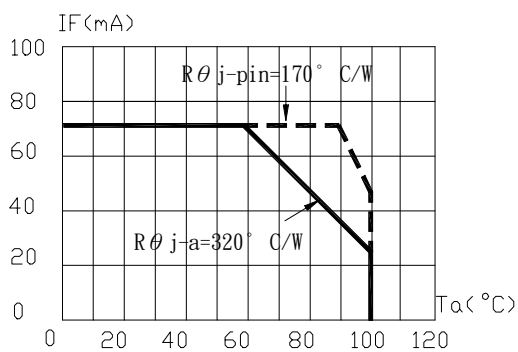

FIG.5 MAXIMUM FORWARD DC CURRENT VS TEMPERATURE, DERATING BASED ON $T_{jmax}=120^{\circ}C$

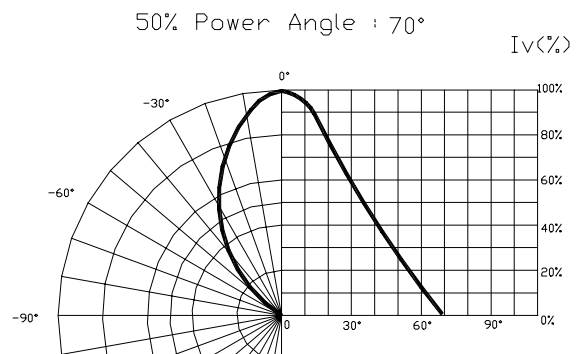

FIG.6 SPATIAL DISTRIBUTION.

1. Cathode PAD Area ($0.18 \times 0.18 \times 2 \text{inch}^2$)
2. Height above nominal seating plane in inches(0.3inch)

DOC. NO. :	SPE/LP377THR1-70G
REF:	A 01B07

TERMS AND CONDITIONS

1. Cotco warrants that its LEDs conform to the foregoing specifications and that Cotco will convey good title to all LEDs sold.
2. Cotco disclaims all other warranties including the implied warranties of merchantability and fitness for a particular purpose.
3. In the event any LED supplied by Cotco is found not to conform to the foregoing specifications within ninety days of receipt. Cotco will repair or replace the LED, at Cotco's option, provided that user
 - a) promptly notifies Cotco in writing of the details of the defect
 - b) ships the LED at user's expense to Cotco for examination, and the defect is due to the negligence of Cotco and not mishandling or misuse by user.
4. Cotco cannot take any responsibility for any troubles that are caused by using the LEDs at conditions exceeding our specifications.
5. These specifications are applied only when a LED stands alone and it is strongly recommended that the user of the LED confirms the properties upon assembly. Cotco is not responsible for failures caused during and after assembling.
6. A claim report stating details about the defect shall be made when returning defective LEDs. Cotco will investigate the report immediately and inform the user of the results.
7. These LEDs are designed and manufactured for standard applications such as electric home appliances, communication equipment, office equipment, electronic instrumentation and so on. It is recommended to consult with Cotco in advance if user's application requires any particular quality or reliability that concerns human life. Examples would be medical equipment, aerospace applications, traffic signals, safety system equipment and so on.
8. Cotco's liability for defective lamps shall be limited to replacement and in no event shall Cotco be liable for consequential damages or lost profits.
9. Both Cotco and the user confirm that any agreement regarding the quality is based only on the specifications herein. The agreement confirmed before this specifications shall become ineffective if it is not stated in these specifications.
10. Both parties shall sincerely try to find a solution when any inconvenience is found in these specifications.
11. The user's approval shall be required when Cotco modifies the design or the manufacturing process that would affect the characteristics, performance reliability and so on.
12. These specifications can be revised on mutual agreement.
13. Cotco understands that user accepts the content of this specification, if user does not return these specifications with your signature within 3 weeks after your receipt.

COTCO

USER

PREPARED: _____

CHECKED: _____

APPROVED: _____

COTCO LUMINANT DEVICE (HUIZHOU) LTD.

DOC. NO. :	SPE/LP377THR1-70G
REF:	A 01B07

BULK PACKAGING

PACKING SPECIFICATIONS :

- 1).The packing only appropriate for P4 LED lamps
- 2).packing quantity : 60pcs/tube
- 3).The cardboard box A contains 50 tube
- 4).The cardboard box B contains 6 cardboard box A at maximum.

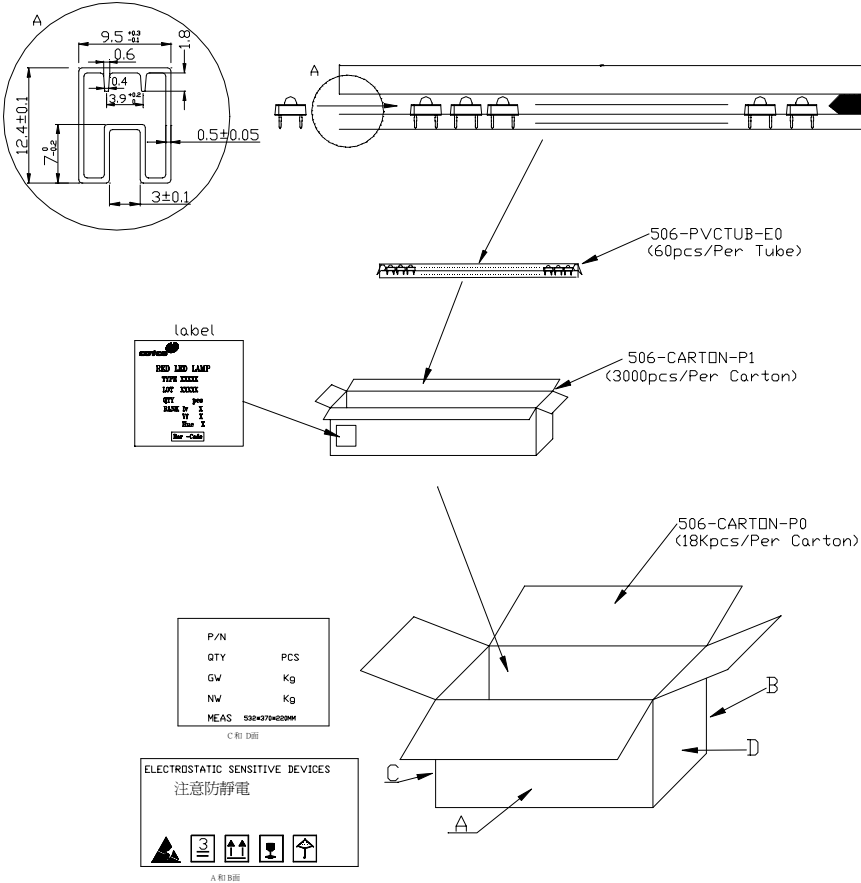

COTCO LUMINANT DEVICE (HUIZHOU) LTD.	Scale 4 : 1		Allow 0.25	
	Title: OUTLINE DIMENSION	Date:	Units: mm	Approved
	Model #	LP377THR1-70G		Checked
	ECN#	ECN-H20010130		
DRFT BY	YINBX			
CHANGE DESCRIPTION	FIRST RELEASE			
REF	A 01B07			