

## High Input Voltage SMPS Start-up / Linear Regulator

### Ordering Information

Max. Input Voltage	Order Number / Package				
	TO-92	TO-243AA*	TO-220	SO-8	Die
450V	LR645N3	LR645N8	LR645N5	LR645LG	LR645ND

\*Same as SOT-89. Product supplied on 2000 piece carrier tape reels.

### Features

- Accepts inputs from 15V to 450V
- Compatible with industry standard PWM ICs. See application note AN-H28.
- Output currents up to 3mA continuous, 30mA peak
- Supply current typically 50µA
- Line regulation typically 0.1mV/V
- Output can be trimmed from 8.0V to 12V
- Output current can be increased to 150mA with external FET

### Applications

- Off-line SMPS startup circuits (pulse loads)
- Low power off-line regulators
- Regulators for noisy inputs

### Caution

The LR6 does NOT provide galvanic isolation. When operated from an AC line, potentially lethal voltages can be present on the IC. Adequate means of protecting the end user from such voltages must be provided by the circuit developer.

### Absolute Maximum Ratings

Input Voltage	450V
Output Voltage	15.5V
Operating and Storage Temperature	-55°C to +150°C
Soldering Temperature*	300°C

\*Distance of 1.6mm from case for 10 seconds

For detailed circuit and application information, please refer to application note AN-H28.

### General Description

The Supertex LR6 is a high input voltage, low output current linear regulator. It has a 3-terminal fixed output voltage version available in TO-92, TO-220 and SOT-89 packages as well as an adjustable voltage version available in 8 pin SOIC package. The 3-terminal version functions like any other low voltage 3-terminal regulator except it allows the use of much higher input voltages. When used in a SMPS start-up circuit, it eliminates the need for large power resistors. In this application, current is drawn from the high voltage line only during start-up. Only leakage current flows after start-up thereby reducing the continuous power dissipation to a few milliwatts.

The adjustable voltage version allows trimming of the output voltage from 8V to 12V. This version can also be connected to an external depletion mode MOSFET for increased output current. When used in conjunction with Supertex depletion mode MOSFET DN2540N5, up to a 150mA is achieved.

(continued on page 14-3)

### Pin Configuration

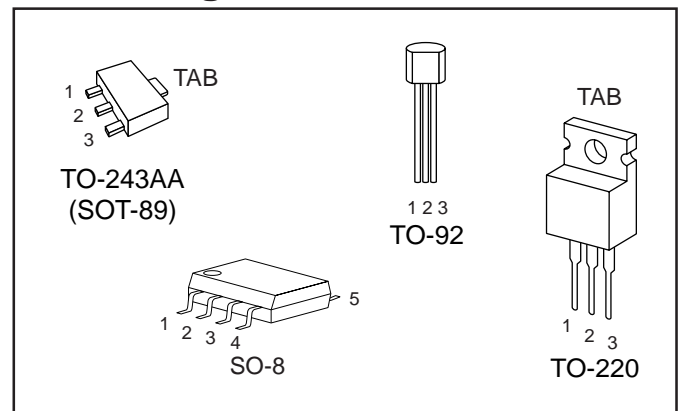

	+V <sub>IN</sub>	GND	V <sub>OUT</sub>	Trim	Gate
TO-92	1	2	3	—	—
TO-243AA	1	2, TAB	3	—	—
TO-220	1	2, TAB	3	—	—
P-DIP	1	3	4	5	7



General Description (Continued from page 14-1)

**LR6: SMPS Start-Up Circuit**

One of the main applications for the LR6 is a start-up circuit for off-line switch-mode power supplies (SMPS) as shown in Figure 1. A minimum output capacitance of 0.01μF is recommended for stability. The wide operating input voltage range of the LR6 allows the SMPS to operate and start-up from rectified AC or a DC voltage 15V to 450V without adjustment.

During start-up, the LR6 powers the V<sub>CC</sub> line of the PWM IC with a nominal output voltage of 10V. The auxiliary voltage connected through a diode to the V<sub>OUT</sub> pin of the LR6 will start to increase. When the auxiliary voltage becomes larger than the output voltage the LR6 turns OFF its internal high voltage input line and output voltage allowing the auxiliary voltage to power the V<sub>CC</sub> line of the PWM IC. The input current drawn by the LR6 from the high voltage line after start-up will therefore only be leakage current of the internal MOSFET switch, which is typically 0.1μA.

The 3-terminal version shown in Figure 1 has load regulation guaranteed from 0 to 3.0mA at a fixed nominal output voltage of 10V. Applications requiring higher output current and/or a different output voltage can use the 8 pin adjustable version.

**LR6: High Current SMPS Start-Up Circuit**

The 8 pin version of the LR6 has connections for an external depletion-mode MOSFET for higher output current and external resistors for adjustable output voltage. As shown in Figure 2, the output current is increased to 150mA by using the Supertex 400V depletion-mode MOSFET DN2540. The maximum operating input voltage will be limited by the drain-to-source breakdown voltage of the external MOSFET, but cannot exceed the 450V rating of LR6.

The output voltage can be adjusted from 8V to 12V with 2 external resistors, R1 and R2. The ratio of R2/R1 determines the output voltage. R2 is connected between the V<sub>OUT</sub> and Trim pins. R1 is connected between Trim and GND pins. Figure 5 is a curve showing output voltage versus resistor ratio R2/R1. The optimum range for R1 + R2 is 200KΩ to 300KΩ. This minimizes loading and optimizes accuracy of the output voltage. Figure 5 uses an R1 + R2 of 250KΩ.

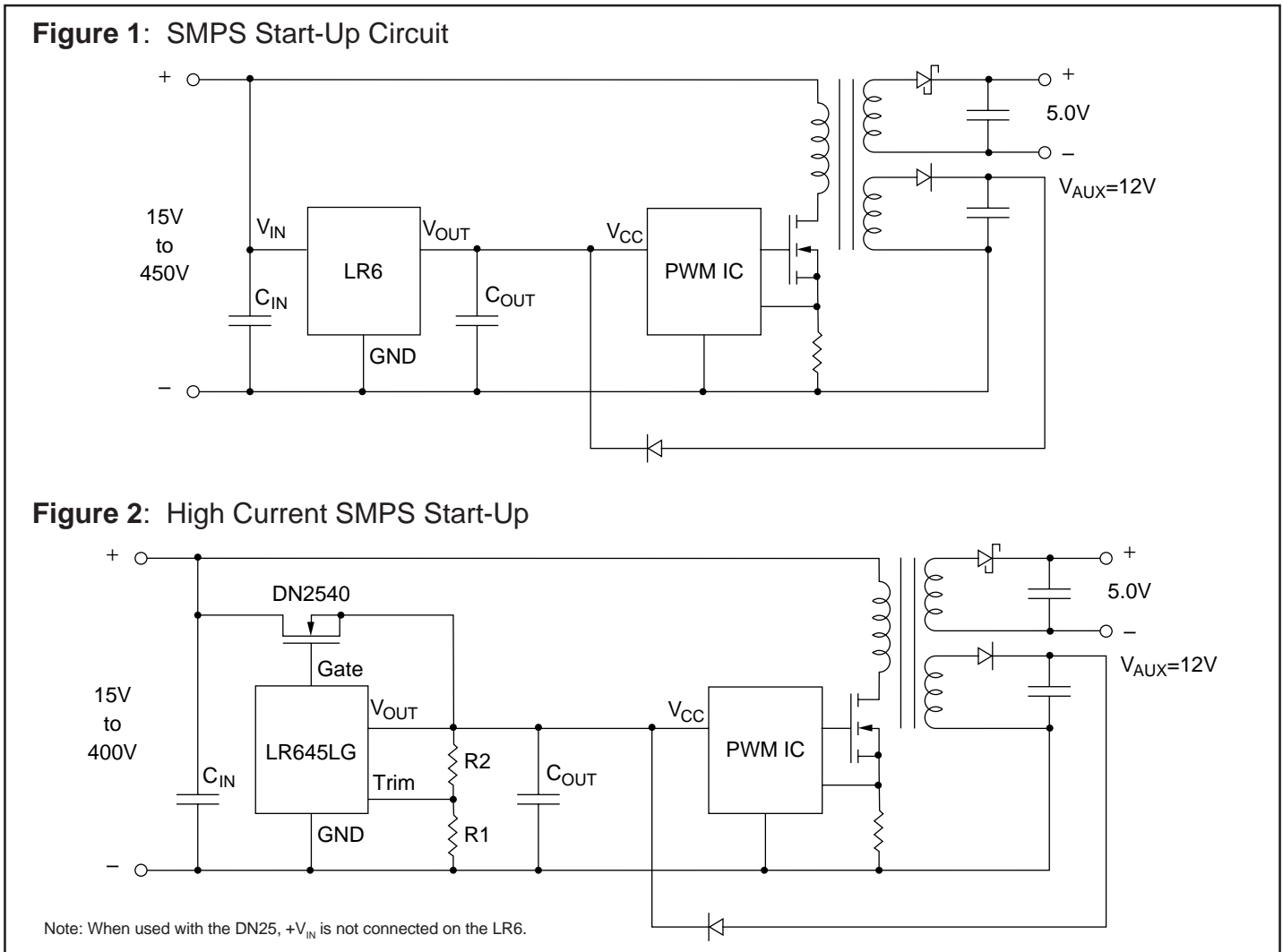

## LR6:Off Line Linear Regulator

Circuits requiring low voltages to operate logic and analog circuits benefit from the LR6. The conventional use of step down transformers can be eliminated thereby saving space and cost. Some examples of these applications are proximity controlled light switches, street lamp control, and low voltage power supplies for appliances such as washing machines, dishwashers, and refrigerators.

The wide operating input voltage range of 15V to 450V as well as the ripple rejection ratio of 50dB minimum allow the use of small high voltage input capacitor. The input AC line can be either full-wave or half-wave rectified. A minimum output capacitance of 0.01µF is recommended for output stability.

Figure 3 shows the LR6 as a pre-regulator to a precision regulator for high precision regulation. Higher output current is also possible by using an external depletion-mode MOSFET DN2540N5 as shown in Figure 4.

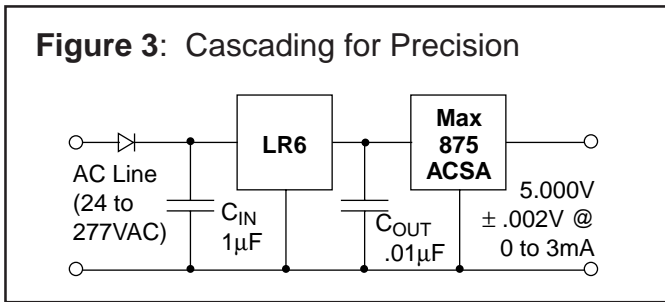

## Power Dissipation Considerations

The LR6 is a true linear regulator. Its power dissipation is therefore a function of input voltage and output load current. For example, if the LR6 is providing a continuous load current of 3mA at 10V while its input voltage is 400V, total dissipation in the LR6

will be:

$$\begin{aligned}
 P_{DISS} &= (V_{IN} - V_{OUT}) \times (I_{OUT} + I_{MAX\ QUIESCENT}) \\
 &= (400V - 10V) \times (3.0mA + 150\mu A) \\
 &= 1.23\text{ Watts}
 \end{aligned}$$

The 1.23 watts is for continuous operation. This is within the dissipation capabilities of the TO-220 and SOT-89 packages. See Page 14-2, thermal characteristics, for deratings.

For SMPS start-up applications, the output current is usually required only during start-up. This duration depends upon the auxiliary supply output capacitor and C<sub>OUT</sub> but is typically a few hundred milliseconds.

All package types of the LR6 have been characterized for use with a C<sub>OUT</sub> of at least 10µF , and an AC line of 277V.

**Figure 5:**  
Typical Output Voltage vs. Resistor Ratio

