

## High Transfer Efficiency AC Input Type Photocoupler LTV-8141 Series

### Features

- AC input response
- High current transfer ratio  
(CTR : MIN. 600% at  $I_F = \pm 1\text{mA}$ ,  $V_{CE} = 2\text{V}$ )
- High input-output isolation voltage:  
( $V_{ISO} : 5,000V_{rms}$ )
- Compact dual-in-line package  
LTV-8141 : 1-channel type  
LTV-8241 : 2-channel type  
LTV-8441 : 4-channel type
- UL approved (No. E113898)
- TUV approved (No. R9653630)
- CSA approved (No. CA91533-1)
- FIMKO approved (No. 193422)
- NEMKO approved (No. P96103013)
- DEMKO approved (No. 303986)
- SEMKO approved (No. 9646047/01-30)
- Options available :
  - Leads with 0.4"(10.16mm)spacing (M Type)
  - Leads bends for surface mounting(S Type)
  - Tape and Reel of Type I for SMD(Add"-TA"Suffix)
  - Tape and Reel of Type II for SMD(Add"-TA1"Suffix)

### Applications

1. System appliances, measuring instruments.
2. Industrial robots.
3. Copiers, automatic vending machines.
4. Signal transmission between circuits of different potentials and impedances.

### Package Dimensions

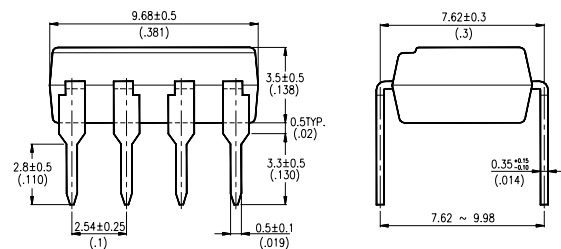
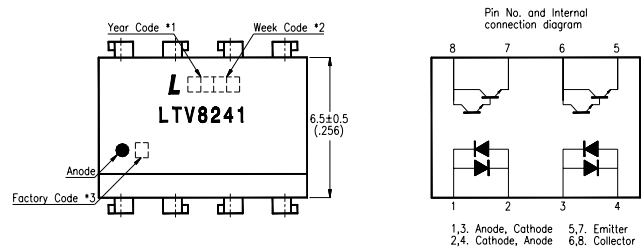
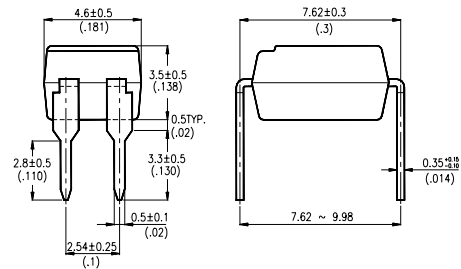
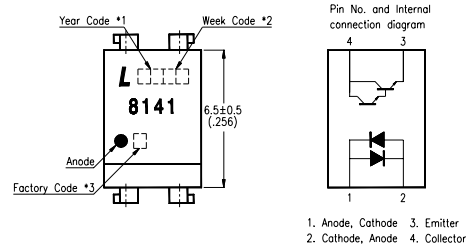

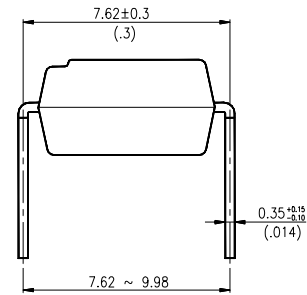
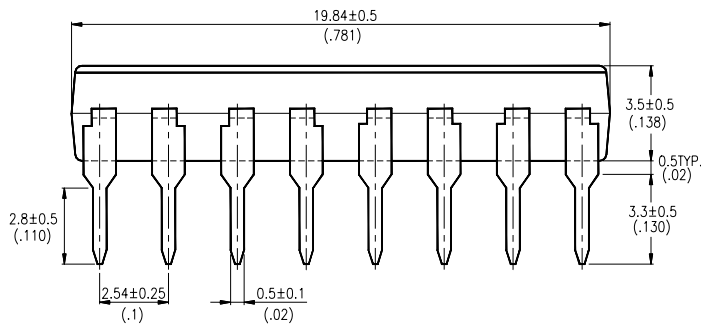
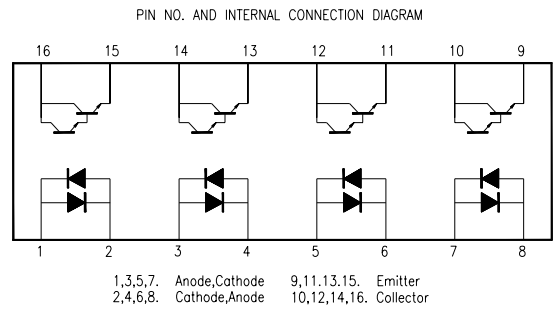
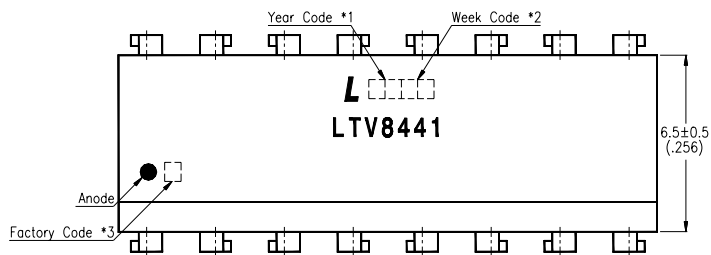

**Note:**

1. Year date code.
2. 2-digit work week.
3. Factory code shall be marked (Z : Taiwan, Y : Thailand).
4. All dimensions are in millimeters (inches).
5. Tolerance is  $\pm 0.25\text{mm}$  (.010") unless otherwise noted.
6. Specifications are subject to change without notice.

**Ordering Information**

Part Number	Package	Safety Standard Approval	Application part number	
LTV-8141 LTV-8141M LTV-8141S LTV-8141S-TA LTV-8141S-TA1	4-pin DIP 4-pin (leads with 0.4" spacing) 4-pin (lead bends for surface mount) 4-pin (tape and reel packaging of type I) 4-pin (tape and reel packaging of type II)	<ul style="list-style-type: none"> <li>• UL approved</li> <li>• TUV approved</li> <li>• CSA approved</li> <li>• FIMKO approved</li> <li>• NEMKO approved</li> <li>• SEMKO approved</li> <li>• DEMKO approved</li> </ul>	LTV-8141	
LTV-8241 LTV-8241M LTV-8241S LTV-8241S-TA LTV-8241S-TA1	8-pin DIP 8-pin (leads with 0.4" spacing) 8-pin (lead bends for surface mount) 8-pin (tape and reel packaging of type I) 8-pin (tape and reel packaging of type II)		LTV-8241	
LTV-8441 LTV-8441M LTV-8441S LTV-8441S-TA LTV-8441S-TA1	16-pin DIP 16-pin (leads with 0.4" spacing) 16-pin (lead bends for surface mount) 16-pin (tape and reel packaging of type I) 16-pin (tape and reel packaging of type II)		LTV-8441	
LTV8141-V LTV8141M-V LTV8141S-V LTV8141STA-V LTV8141STA1-V	4-pin DIP 4-pin (leads with 0.4" spacing) 4-pin (lead bends for surface mount) 4-pin (tape and reel packaging of type I) 4-pin (tape and reel packaging of type II)		<ul style="list-style-type: none"> <li>• VDE approved</li> </ul>	LTV-8141
LTV8241-V LTV8241M-V LTV8241S-V LTV8241STA-V LTV8241STA1-V	8-pin DIP 8-pin (leads with 0.4" spacing) 8-pin (lead bends for surface mount) 8-pin (tape and reel packaging of type I) 8-pin (tape and reel packaging of type II)			LTV-8241
LTV8441-V LTV8441M-V LTV8441S-V LTV8441STA-V LTV8441STA1-V	16-pin DIP 16-pin (leads with 0.4" spacing) 16-pin (lead bends for surface mount) 16-pin (tape and reel packaging of type I) 16-pin (tape and reel packaging of type II)			LTV-8441

## Absolute Maximum Ratings

(Ta=25°C)

Parameter		Symbol	Rating	Unit
Input	Forward Current	I <sub>F</sub>	± 50	mA
	Power Dissipation	P	70	mW
Output	Collector-Emitter Voltage	V <sub>CEO</sub>	35	V
	Emitter-Collector Voltage	V <sub>ECO</sub>	6	V
	Collector Current	I <sub>C</sub>	80	mA
	Collector Power Dissipation	P <sub>C</sub>	150	mW
Total Power Dissipation		P <sub>tot</sub>	200	mW
Operating Temperature		T <sub>opr</sub>	-30~+100	°C
Storage Temperature		T <sub>stg</sub>	-55~+125	°C
*1.Isolation Voltage		V <sub>iso</sub>	5	KV <sub>rms</sub>
*2.Soldering Temperature		T <sub>sol</sub>	260	°C

\*1. AC for 1 minute, R.H. = 40 ~ 60%

• Isolation voltage shall be measured using the following method.

(1)Short between anode and cathode on the primary side and between collector, emitter and base on the secondary side.

(2)The isolation voltage tester with zero-cross circuit shall be used.

(3)The waveform of applied voltage shall be a sine wave.

\*2. For 10 seconds.

## Electrical/Optical Characteristics

(Ta=25°C)

Parameter		Symbol	Min.	Typ.	Max.	Unit	Conditions
Input	Forward Voltage	V <sub>F</sub>	—	1.2	1.4	V	I <sub>F</sub> = ± 20mA
	Terminal Capacitance	C <sub>t</sub>	—	50	250	pF	V=0, f=1KHz
Output	Collector Dark Current	I <sub>CEO</sub>	—	—	1	μA	V <sub>CE</sub> =10V
	Collector-Emitter Breakdown Voltage	BV <sub>CEO</sub>	35	—	—	V	I <sub>C</sub> =0.1mA
	Emitter-Collector Breakdown Voltage	BV <sub>ECO</sub>	6	—	—	V	I <sub>E</sub> =10 μA
Transfer Characteristics	Collector Current	I <sub>C</sub>	6	—	75	mA	I <sub>F</sub> = ± 1mA V <sub>CE</sub> =2V
	*Current Transfer Ratio	CTR	600	—	7,500	%	
	Collector-emitter Saturation Voltage	V <sub>CE(sat)</sub>	—	0.8	1.0	V	I <sub>F</sub> = ± 20mA, I <sub>C</sub> =5mA
	Isolation Resistance	R <sub>ISO</sub>	50	100	—	GΩ	DC500V, 40~60% R.H.
	Floating Capacitance	C <sub>f</sub>	—	0.6	1.0	pF	V=0, f=1MHz
	Cut-off Frequency	f <sub>c</sub>	1	6	—	KHz	V <sub>CE</sub> =5V, I <sub>C</sub> =2mA R <sub>L</sub> =100 Ω, -3dB
	Response Time (Rise)	t <sub>r</sub>	—	60	300	μs	V <sub>CE</sub> =2V, I <sub>C</sub> =10mA
Response Time (Fall)	t <sub>f</sub>	—	53	250	μs	R <sub>L</sub> =100 Ω	

\*CTR=  $\frac{I_C}{I_F} \times 100\%$