

**NMOS 16K (2K x 8) UV EPROM**

- 2048 x 8 ORGANIZATION
- 525mW Max ACTIVE POWER, 132mW Max STANDBY POWER
- ACCESS TIME:
  - M2716-1 is 350ns
  - M2716 is 450ns
- SINGLE 5V SUPPLY VOLTAGE
- STATIC-NO CLOCKS REQUIRED
- INPUTS and OUTPUTS TTL COMPATIBLE DURING BOTH READ and PROGRAM MODES
- THREE-STATE OUTPUT with TIED-OR-CAPABILITY
- EXTENDED TEMPERATURE RANGE
- PROGRAMMING VOLTAGE: 25V

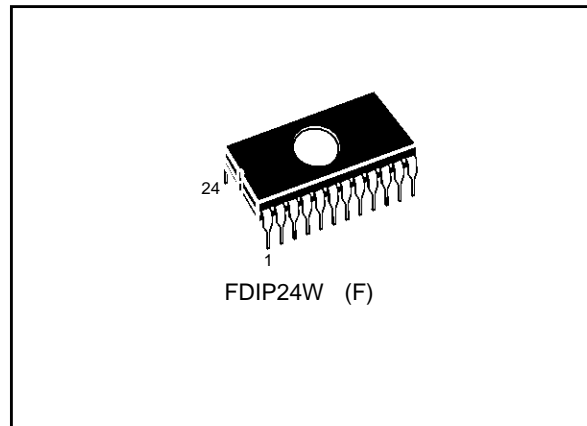

**DESCRIPTION**

The M2716 is a 16,384 bit UV erasable and electrically programmable memory EPROM, ideally suited for applications where fast turn around and pattern experimentation are important requirements.

The M2716 is housed in a 24 pin Window Ceramic Frit-Seal Dual-in-Line package. The transparent lid allows the user to expose the chip to ultraviolet light to erase the bit pattern. A new pattern can then be written to the device by following the programming procedure.

**Figure 1. Logic Diagram**

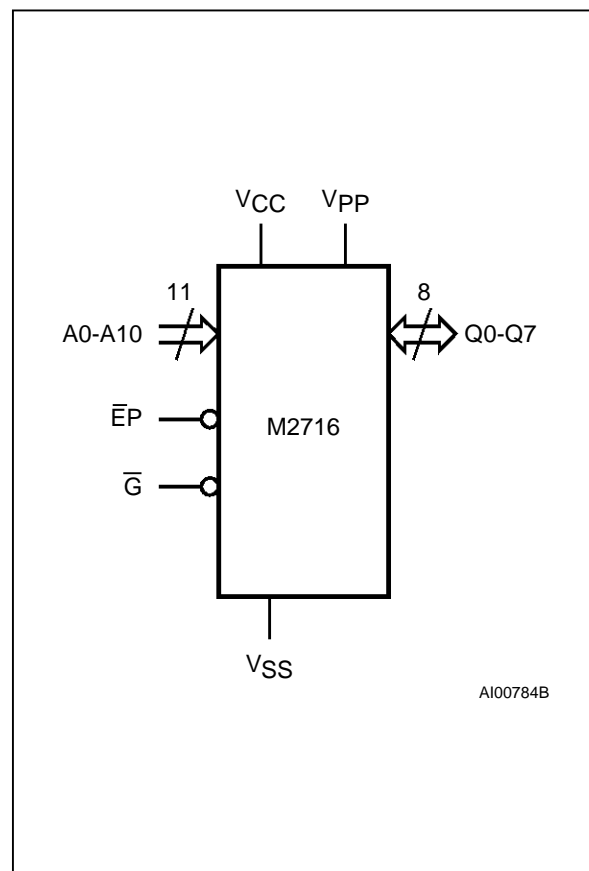

**Table 1. Signal Names**

A0 - A10	Address Inputs
Q0 - Q7	Data Outputs
$\bar{E}P$	Chip Enable / Program
$\bar{G}$	Output Enable
V <sub>PP</sub>	Program Supply
V <sub>CC</sub>	Supply Voltage
V <sub>SS</sub>	Ground

Table 2. Absolute Maximum Ratings

Symbol	Parameter	Value	Unit
$T_A$	Ambient Operating Temperature grade 1 grade 6	0 to 70 -40 to 85	°C
$T_{BIAS}$	Temperature Under Bias grade 1 grade 6	-10 to 80 -50 to 95	°C
$T_{STG}$	Storage Temperature	-65 to 125	°C
$V_{CC}$	Supply Voltage	-0.3 to 6	V
$V_{IO}$	Input or Output Voltages	-0.3 to 6	V
$V_{PP}$	Program Supply	-0.3 to 26.5	V
$P_D$	Power Dissipation	1.5	W

**Note:** Except for the rating "Operating Temperature Range", stresses above those listed in the Table "Absolute Maximum Ratings" may cause permanent damage to the device. These are stress ratings only and operation of the device at these or any other conditions above those indicated in the Operating sections of this specification is not implied. Exposure to Absolute Maximum Rating conditions for extended periods may affect device reliability. Refer also to the SGS-THOMSON SURE Program and other relevant quality documents.

Figure 2. DIP Pin Connections

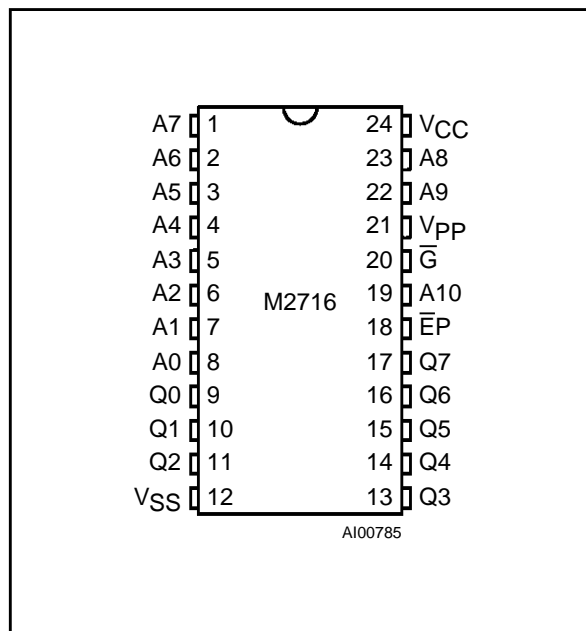

## DEVICE OPERATION

The M2716 has 3 modes of operation in the normal system environment. These are shown in Table 3.

**Read Mode.** The M2716 read operation requires that  $\bar{G} = V_{IL}$ ,  $\bar{EP} = V_{IL}$  and that addresses A0-A10 have been stabilized. Valid data will appear on the output pins after time  $t_{AVQV}$ ,  $t_{GLQV}$  or  $t_{ELQV}$  (see Switching Time Waveforms) depending on which is limiting.

**Deselect Mode.** The M2716 is deselected by making  $\bar{G} = V_{IH}$ . This mode is independent of  $\bar{EP}$  and the condition of the addresses. The outputs are Hi-Z when  $\bar{G} = V_{IH}$ . This allows tied-OR of 2 or more M2716's for memory expansion.

**Standby Mode (Power Down).** The M2716 may be powered down to the standby mode by making  $\bar{EP} = V_{IH}$ . This is independent of  $\bar{G}$  and automatically puts the outputs in the Hi-Z state. The power is reduced to 25% (132 mW max) of the normal operating power.  $V_{CC}$  and  $V_{PP}$  must be maintained at 5V. Access time at power up remains either  $t_{AVQV}$  or  $t_{ELQV}$  (see Switching Time Waveforms).

## Programming

The M2716 is shipped from SGS-THOMSON completely erased. All bits will be at "1" level (output high) in this initial state and after any full erasure. Table 3 shows the 3 programming modes.

**Program Mode.** The M2716 is programmed by introducing "0"s into the desired locations. This is done 8 bits (a byte) at a time. Any individual address, sequential addresses, or addresses chosen at random may be programmed. Any or all of the 8 bits associated with an address location may be programmed with a single program pulse applied to the  $\bar{EP}$  pin. All input voltage levels including the program pulse on chip enable are TTL compatible.

The programming sequence is: with  $V_{PP} = 25V$ ,  $V_{CC} = 5V$ ,  $\bar{G} = V_{IH}$  and  $\bar{EP} = V_{IL}$ , an address is selected and the desired data word is applied to the output pins ( $V_{IL} = "0"$  and  $V_{IH} = "1"$  for both address and data). After the address and data signals are stable the program pin is pulsed from  $V_{IL}$  to  $V_{IH}$  with a

**DEVICE OPERATION** (cont'd)

pulse width between 45ms and 55ms. Multiple pulses are not needed but will not cause device damage. No pins should be left open. A high level ( $V_{IH}$  or higher) must not be maintained longer than  $t_{PHPL}$  (max) on the program pin during programming. M2716's may be programmed in parallel in this mode.

**Program Verify Mode.** The programming of the M2716 may be verified either one byte at a time during the programming (as shown in Figure 6) or by reading all of the bytes out at the end of the programming sequence. This can be done with  $V_{PP} = 25V$  or  $5V$  in either case.  $V_{PP}$  must be at  $5V$  for all operating modes and can be maintained at  $25V$  for all programming modes.

**Program Inhibit Mode.** The program inhibit mode allows several M2716's to be programmed simultaneously with different data for each one by controlling which ones receive the program pulse. All similar inputs of the M2716 may be paralleled. Pulsing the program pin (from  $V_{IL}$  to  $V_{IH}$ ) will program a unit while inhibiting the program pulse to a unit will keep it from being programmed and keeping  $\bar{G} = V_{IH}$  will put its outputs in the Hi-Z state.

**ERASURE OPERATION**

The M2716 is erased by exposure to high intensity ultraviolet light through the transparent window. This exposure discharges the floating gate to its initial state through induced photo current. It is recommended that the M2716 be kept out of direct sunlight. The UV content of sunlight may cause a partial erasure of some bits in a relatively short period of time.

An ultraviolet source of  $2537 \text{ \AA}$  yielding a total integrated dosage of  $15 \text{ watt-seconds/cm}^2$  power rating is used. The M2716 to be erased should be placed 1 inch away from the lamp and no filters should be used.

An erasure system should be calibrated periodically. The erasure time is increased by the square of the distance (if the distance is doubled the erasure time goes up by a factor of 4). Lamps lose intensity as they age, it is therefore important to periodically check that the UV system is in good order.

This will ensure that the EPROMs are being completely erased. Incomplete erasure will cause symptoms that can be misleading. Programmers, components, and system designs have been erroneously suspected when incomplete erasure was the basic problem.

**Table 3. Operating Modes**

Mode	$\bar{EP}$	$\bar{G}$	$V_{PP}$	Q0 - Q7
Read	$V_{IL}$	$V_{IL}$	$V_{CC}$	Data Out
Program	$V_{IH}$ Pulse	$V_{IH}$	$V_{PP}$	Data In
Verify	$V_{IL}$	$V_{IL}$	$V_{PP}$ or $V_{CC}$	Data Out
Program Inhibit	$V_{IL}$	$V_{IH}$	$V_{PP}$	Hi-Z
Deselect	X	$V_{IH}$	$V_{CC}$	Hi-Z
Standby	$V_{IH}$	X	$V_{CC}$	Hi-Z

Note: X =  $V_{IH}$  or  $V_{IL}$ .

**AC MEASUREMENT CONDITIONS**

Input Rise and Fall Times  $\leq 20\text{ns}$   
 Input Pulse Voltages 0.45V to 2.4V  
 Input and Output Timing Ref. Voltages 0.8V to 2.0V

Note that Output Hi-Z is defined as the point where data is no longer driven.

**Figure 3. AC Testing Input Output Waveforms**

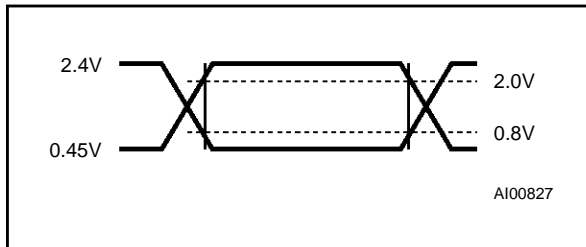

**Figure 4. AC Testing Load Circuit**

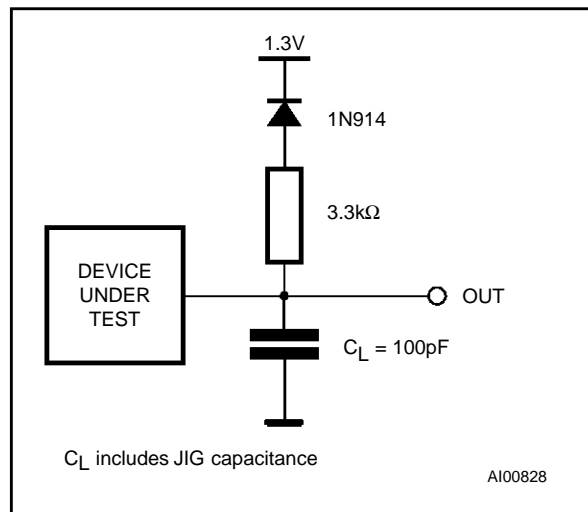

**Table 4. Capacitance<sup>(1)</sup>** ( $T_A = 25\text{ }^\circ\text{C}$ ,  $f = 1\text{ MHz}$ )

Symbol	Parameter	Test Condition	Min	Max	Unit
$C_{IN}$	Input Capacitance	$V_{IN} = 0V$		6	pF
$C_{OUT}$	Output Capacitance	$V_{OUT} = 0V$		12	pF

Note: 1. Sampled only, not 100% tested.

**Table 5. Read Mode DC Characteristics<sup>(1)</sup>**

( $T_A = 0\text{ to }70\text{ }^\circ\text{C}$  or  $-40\text{ to }85\text{ }^\circ\text{C}$ ;  $V_{CC} = 5V \pm 5\%$  or  $5V \pm 10\%$ ;  $V_{PP} = V_{CC}$ )

Symbol	Parameter	Test Condition	Min	Max	Unit
$I_{LI}$	Input Leakage Current	$0 \leq V_{IN} \leq V_{CC}$		$\pm 10$	$\mu\text{A}$
$I_{LO}$	Output Leakage Current	$V_{OUT} = V_{CC}$ , $\bar{E}P = V_{CC}$		$\pm 10$	$\mu\text{A}$
$I_{CC}$	Supply Current	$\bar{E}P = V_{IL}$ , $\bar{G} = V_{IL}$		100	mA
$I_{CC1}$	Supply Current (Standby)	$\bar{E}P = V_{IH}$ , $\bar{G} = V_{IL}$		25	mA
$I_{PP}$	Program Current	$V_{PP} = V_{CC}$		5	mA
$V_{IL}$	Input Low Voltage		-0.1	0.8	V
$V_{IH}$	Input High Voltage		2	$V_{CC} + 1$	V
$V_{OL}$	Output Low Voltage	$I_{OL} = 2.1\text{mA}$		0.45	V
$V_{OH}$	Output High Voltage	$I_{OH} = -400\mu\text{A}$	2.4		V

Note: 1.  $V_{CC}$  must be applied simultaneously with or before  $V_{PP}$  and removed simultaneously or after  $V_{PP}$ .

**Table 6. Read Mode AC Characteristics <sup>(1)</sup>**(T<sub>A</sub> = 0 to 70 °C or -40 to 85 °C; V<sub>CC</sub> = 5V ± 5% or 5V ± 10%; V<sub>PP</sub> = V<sub>CC</sub>)

Symbol	Alt	Parameter	Test Condition	M2716				Unit
				-1		blank		
				Min	Max	Min	Max	
t <sub>AVQV</sub>	t <sub>ACC</sub>	Address Valid to Output Valid	$\overline{EP} = V_{IL}, \overline{G} = V_{IL}$		350		450	ns
t <sub>ELQV</sub>	t <sub>CE</sub>	Chip Enable Low to Output Valid	$\overline{G} = V_{IL}$		350		450	ns
t <sub>GLQV</sub>	t <sub>OE</sub>	Output Enable Low to Output Valid	$\overline{EP} = V_{IL}$		120		120	ns
t <sub>EHQZ</sub> <sup>(2)</sup>	t <sub>OD</sub>	Chip Enable High to Output Hi-Z	$\overline{G} = V_{IL}$	0	100	0	100	ns
t <sub>GHQZ</sub> <sup>(2)</sup>	t <sub>DF</sub>	Output Enable High to Output Hi-Z	$\overline{EP} = V_{IL}$	0	100	0	100	ns
t <sub>AXQX</sub>	t <sub>OH</sub>	Address Transition to Output Transition	$\overline{EP} = V_{IL}, \overline{G} = V_{IL}$	0		0		ns

**Notes:** 1. V<sub>CC</sub> must be applied simultaneously with or before V<sub>PP</sub> and removed simultaneously or after V<sub>PP</sub>.

2. Sampled only, not 100% tested.

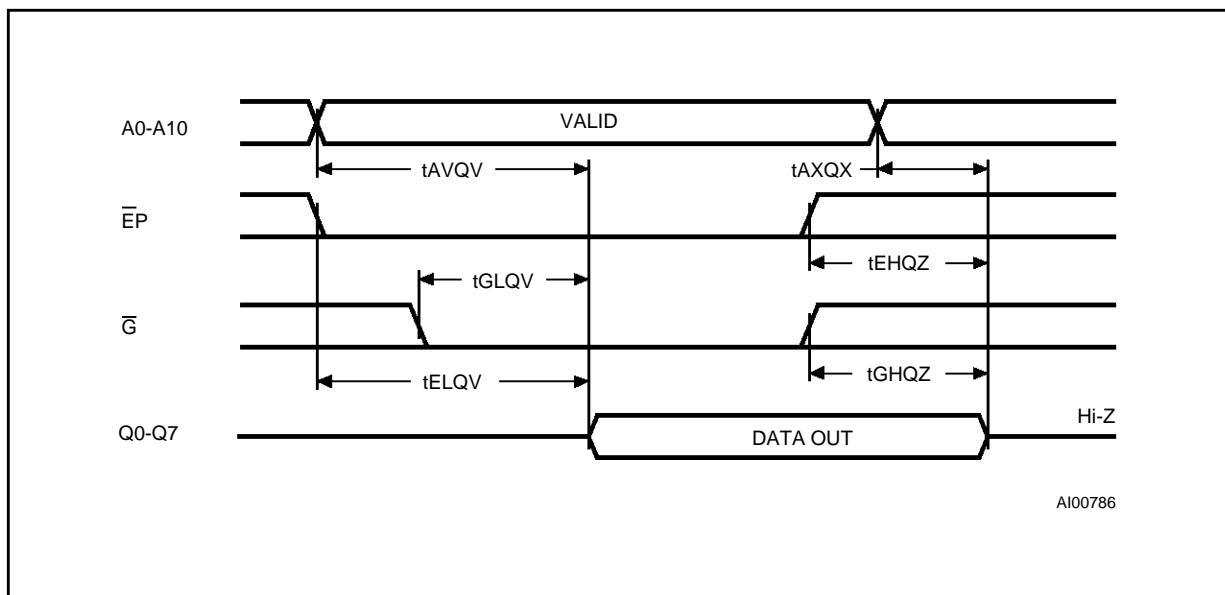
**Figure 5. Read Mode AC Waveforms****Table 7. Programming Mode DC Characteristics <sup>(1)</sup>**(T<sub>A</sub> = 25 °C; V<sub>CC</sub> = 5V ± 5%; V<sub>PP</sub> = 25V ± 1V)

Symbol	Parameter	Test Condition	Min	Max	Unit
I <sub>LI</sub>	Input Leakage Current	V <sub>IL</sub> ≤ V <sub>IN</sub> ≤ V <sub>IH</sub>		±10	μA
I <sub>CC</sub>	Supply Current			100	mA
I <sub>PP</sub>	Program Current			5	mA
I <sub>PP1</sub>	Program Current Pulse	$\overline{EP} = V_{IH}$ Pulse		30	mA
V <sub>IL</sub>	Input Low Voltage		-0.1	0.8	V
V <sub>IH</sub>	Input High Voltage		2	V <sub>CC</sub> + 1	V

**Note:** 1. V<sub>CC</sub> must be applied simultaneously with or before V<sub>PP</sub> and removed simultaneously or after V<sub>PP</sub>.

**Table 8. Programming Mode AC Characteristics <sup>(1)</sup>**  
 (T<sub>A</sub> = 25 °C; V<sub>CC</sub> = 5V ± 5%; V<sub>PP</sub> = 25V ± 1V)

Symbol	Alt	Parameter	Test Condition	Min	Max	Units
t <sub>AVPH</sub>	t <sub>AS</sub>	Address Valid to Program High	$\bar{G} = V_{IH}$	2		μs
t <sub>QVPH</sub>	t <sub>DS</sub>	Input Valid to Program High	$\bar{G} = V_{IH}$	2		μs
t <sub>GHPH</sub>	t <sub>OS</sub>	Output Enable High to Program High		2		μs
t <sub>PL1PL2</sub>	t <sub>PR</sub>	Program Pulse Rise Time		5		ns
t <sub>PH1PH2</sub>	t <sub>PF</sub>	Program Pulse Fall Time		5		ns
t <sub>PHPL</sub>	t <sub>PW</sub>	Program Pulse Width		45	55	ms
t <sub>PLQX</sub>	t <sub>DH</sub>	Program Low to Input Transition		2		μs
t <sub>PLGX</sub>	t <sub>OH</sub>	Program Low to Output Enable Transition		2		μs
t <sub>GLQV</sub>	t <sub>OE</sub>	Output Enable to Output Valid	$\bar{E}P = V_{IL}$		120	ns
t <sub>GHQZ</sub>	t <sub>DF</sub>	Output Enable High to Output Hi-Z		0	100	ns
t <sub>PLAX</sub>	t <sub>AH</sub>	Program Low to Address Transition		2		μs

**Notes:** 1. V<sub>CC</sub> must be applied simultaneously with or before V<sub>PP</sub> and removed simultaneously or after V<sub>PP</sub>.  
 2. Sampled only, not 100% tested.

**Figure 6. Programming and Verify Modes AC Waveforms**

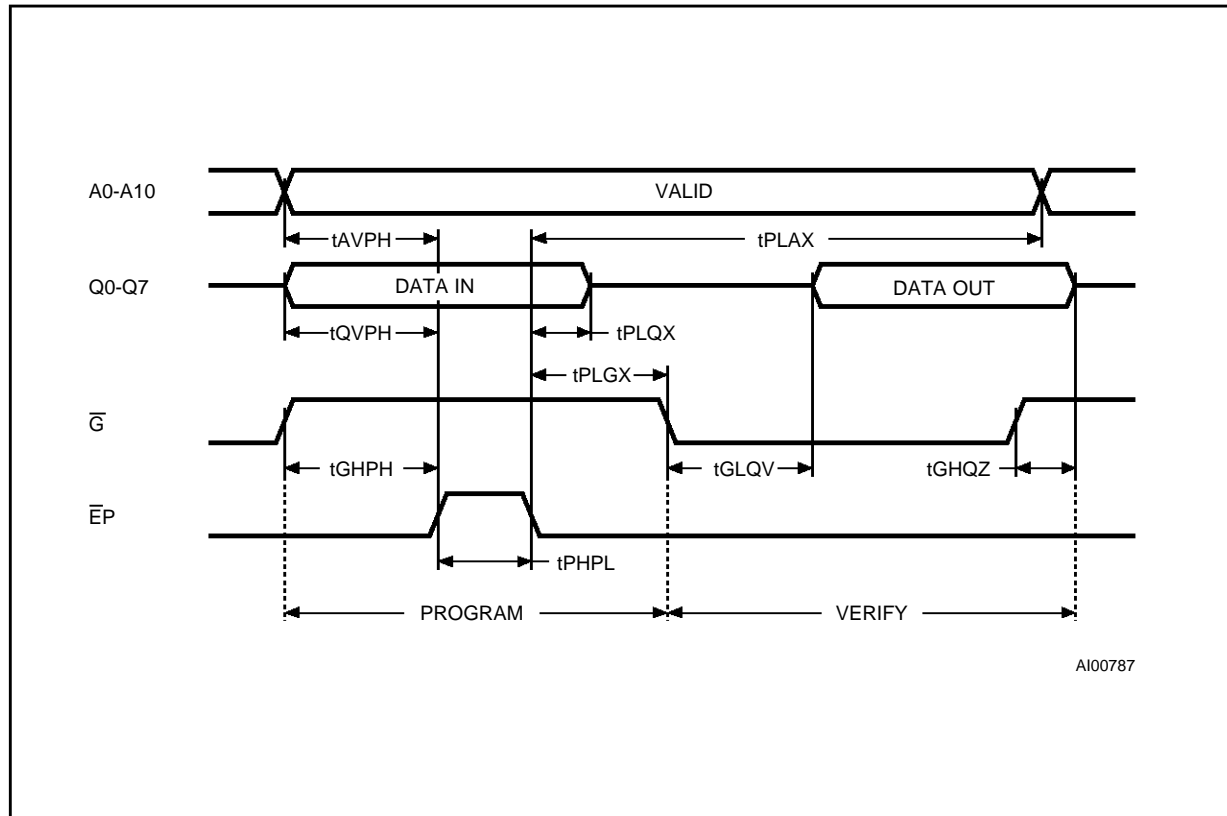

## ORDERING INFORMATION SCHEME

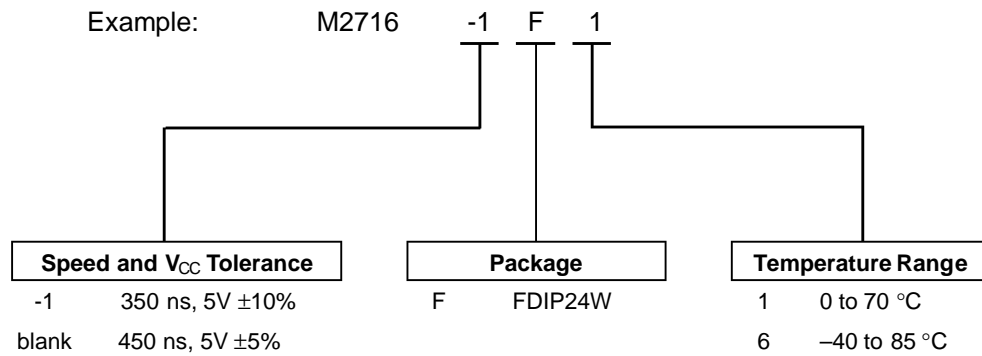

For a list of available options (Speed,  $V_{CC}$  Tolerance, Package, etc...) refer to the current Memory Shortform catalogue.

For further information on any aspect of this device, please contact SGS-THOMSON Sales Office nearest to you.

**FDIP24W - 24 pin Ceramic Frit-seal DIP, with window**

Symb	mm			inches		
	Typ	Min	Max	Typ	Min	Max
A			5.71			0.225
A1		0.50	1.78	0.020		0.070
A2		3.90	5.08	0.154		0.200
B		0.40	0.55	0.016		0.022
B1		1.17	1.42	0.046		0.056
C		0.22	0.31	0.009		0.012
D			32.30			1.272
E		15.40	15.80	0.606		0.622
E1		13.05	13.36	0.514		0.526
e1	2.54	–	–	0.100	–	–
e3	27.94	–	–	1.100	–	–
eA		16.17	18.32	0.637		0.721
L		3.18	4.10	0.125		0.161
S		1.52	2.49	0.060		0.098
∅	7.11	–	–	0.280	–	–
α		4°	15°	4°		15°
N		24			24	

FDIP24W

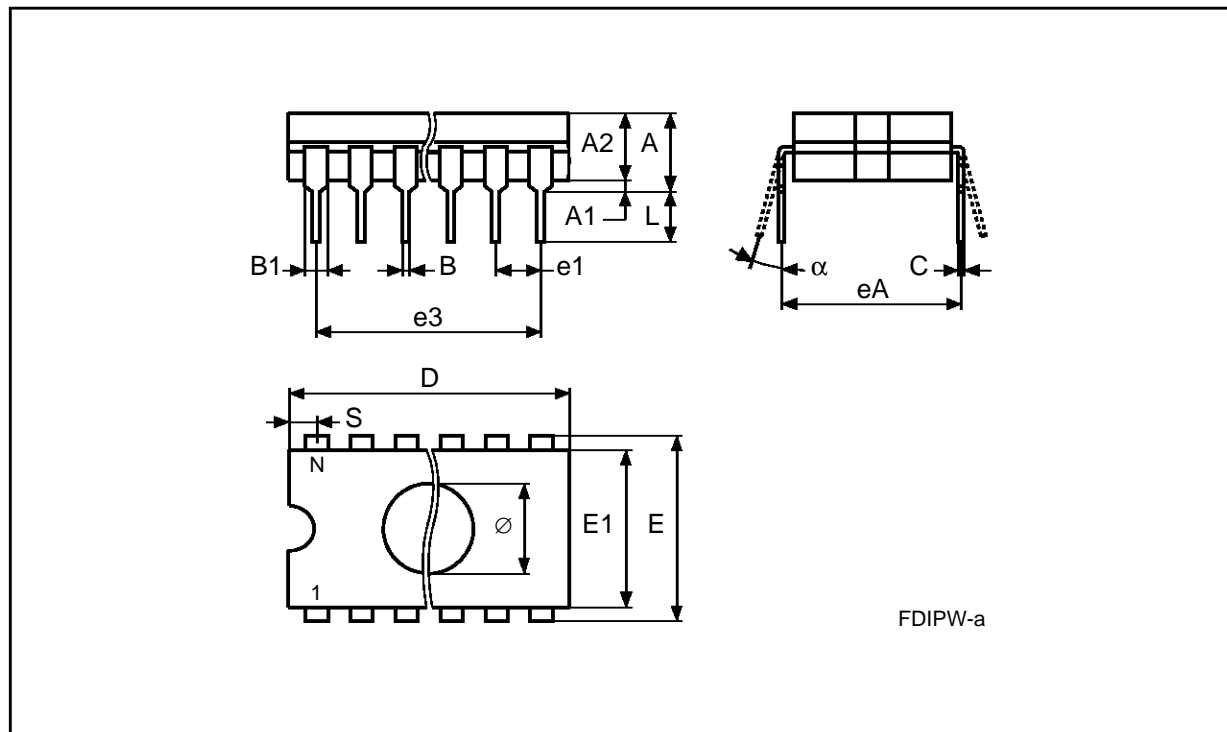

Drawing is not to scale

Information furnished is believed to be accurate and reliable. However, SGS-THOMSON Microelectronics assumes no responsibility for the consequences of use of such information nor for any infringement of patents or other rights of third parties which may result from its use. No license is granted by implication or otherwise under any patent or patent rights of SGS-THOMSON Microelectronics. Specifications mentioned in this publication are subject to change without notice. This publication supersedes and replaces all information previously supplied. SGS-THOMSON Microelectronics products are not authorized for use as critical components in life support devices or systems without express written approval of SGS-THOMSON Microelectronics.

© 1994 SGS-THOMSON Microelectronics - All Rights Reserved

SGS-THOMSON Microelectronics GROUP OF COMPANIES  
Australia - Brazil - China - France - Germany - Hong Kong - Italy - Japan - Korea - Malaysia - Malta - Morocco - The Netherlands -  
Singapore - Spain - Sweden - Switzerland - Taiwan - Thailand - United Kingdom - U.S.A.