

VERY LOW VOLTAGE 2 Megabit (256K x 8) OTP ROM

- VERY LOW VOLTAGE READ OPERATION:
2.7V to 5.5V
- ACCESS TIME
 - 150ns ($T_A = 0$ to 70°C)
 - 200ns ($T_A = -20$ to 70°C)
- LOW POWER CONSUMPTION
 - Active Current 15mA
 - Standby Current $20\mu\text{A}$
- SMALL PACKAGES for SURFACE MOUNTING: PLCC32 and TSOP32
- PROGRAMMING VOLTAGE: 12.75V
- PROGRAMMING TIMES of AROUND 24sec. (PRESTO II ALGORITHM)
- M27W201 is PROGRAMMABLE as M27C2001 with IDENTICAL SIGNATURE

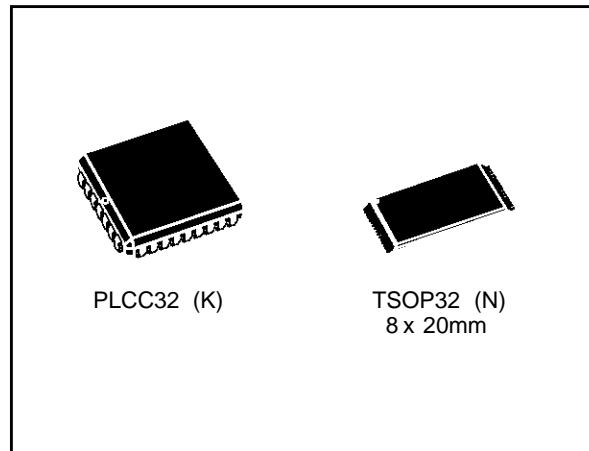

DESCRIPTION

The M27W201 is a very low voltage, low power 2 Megabit One Time Programmable ROM, ideally suited for handheld and portable microprocessor systems requiring large programs. It is organized as 262,144 by 8 bits.

The M27W201 operates in the read mode with a supply voltage as low as 2.7V at -20 to 70°C temperature range. The decrease in operating power allows either a reduction of the size of the battery or an increase in the time between battery recharges. The M27W201 can also be operated as a standard 2 Megabit EPROM (similar to M27C2001) with a 5V power supply.

Table 1. Signal Names

A0 - A17	Address Inputs
Q0 - Q7	Data Outputs
\bar{E}	Chip Enable
\bar{G}	Output Enable
\bar{P}	Program
V_{PP}	Program Supply
V_{CC}	Supply Voltage
V_{SS}	Ground

Figure 1. Logic Diagram

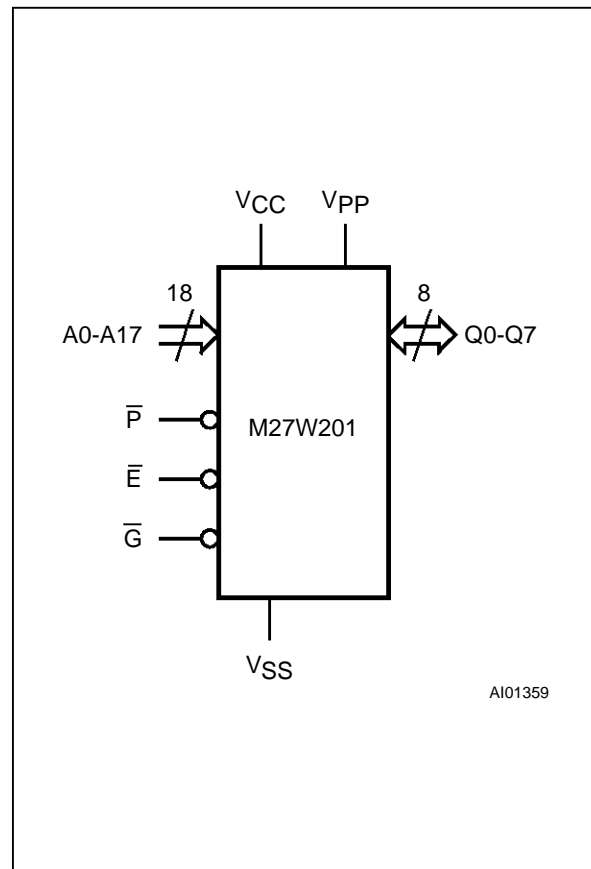

Figure 2A. LCC Pin Connections

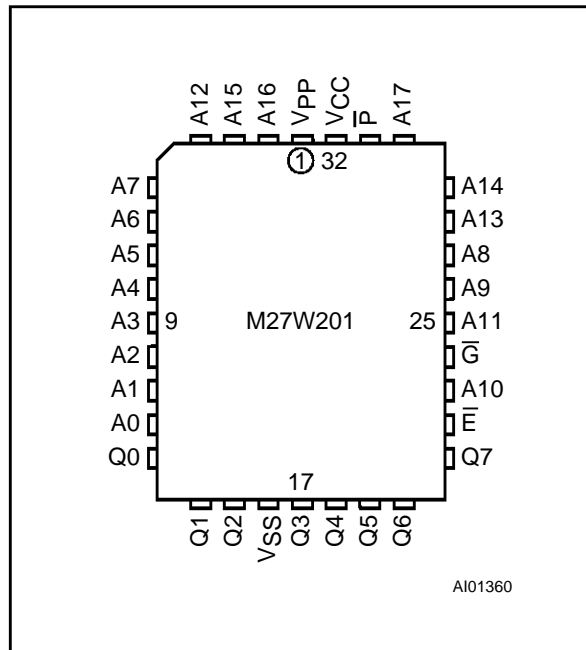

Figure 2B. TSOP Pin Connections

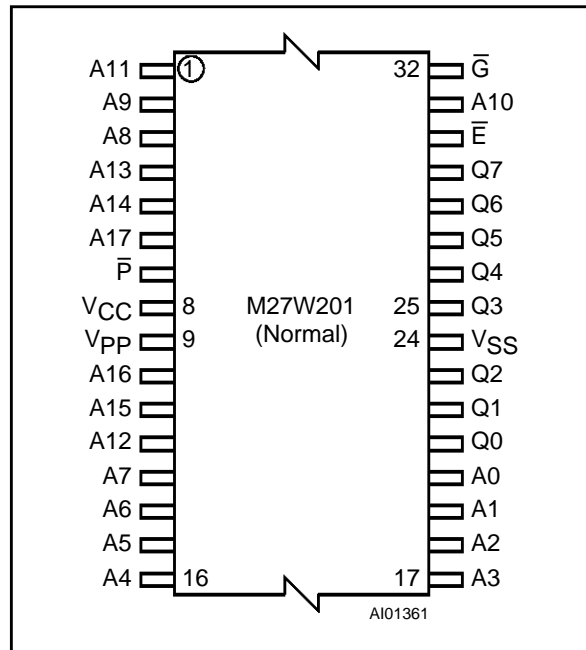

Table 2. Absolute Maximum Ratings ⁽¹⁾

Symbol	Parameter	Value	Unit
T _A	Ambient Operating Temperature	-20 to 70	°C
T _{BIAS}	Temperature Under Bias	-50 to 125	°C
T _{STG}	Storage Temperature	-65 to 150	°C
V _{IO (2)}	Input or Output Voltages (except A9)	-2 to 7	V
V _{CC}	Supply Voltage	-2 to 7	V
V _{A9 (2)}	A9 Voltage	-2 to 13.5	V
V _{PP}	Program Supply Voltage	-2 to 14	V

Notes: 1. Except for the rating "Operating Temperature Range", stresses above those listed in the Table "Absolute Maximum Ratings" may cause permanent damage to the device. These are stress ratings only and operation of the device at these or any other conditions above those indicated in the Operating sections of this specification is not implied. Exposure to Absolute Maximum Rating conditions for extended periods may affect device reliability. Refer also to the SGS-THOMSON SURE Program and other relevant quality documents.
 2. Minimum DC voltage on Input or Output is -0.5V with possible undershoot to -2.0V for a period less than 20ns. Maximum DC voltage on Output is V_{CC} +0.5V with possible overshoot to V_{CC} +2V for a period less than 20ns.

DESCRIPTION (cont'd)

For applications where the content is programmed only one time and erasure is not required, the M27W201 is offered in both Plastic Leaded Chip Carrier and Plastic Thin Small Outline packages.

DEVICE OPERATION

The modes of operation of the M27W201 are listed in the Operating Modes table. A single power supply is required in the read mode. All inputs are TTL levels except for V_{PP} and 12V on A9 for Electronic Signature.

Read Mode

The M27W201 has two control functions, both of which must be logically active in order to obtain data at the outputs. Chip Enable (\bar{E}) is the power control and should be used for device selection. Output Enable (\bar{G}) is the output control and should be used to gate data to the output pins, independent of device selection. Assuming that the addresses are stable, the address access time (t_{AVQV}) is equal to the delay from \bar{E} to output (t_{ELQV}). Data is available at the output after a delay of t_{GLQV} from the falling edge of \bar{G} , assuming that \bar{E} has been low and the addresses have been stable for at least $t_{AVQV} - t_{GLQV}$.

Standby Mode

The M27W201 has a standby mode which reduces the active current from 15mA to 20 μ A with low voltage operation $V_{CC} = 2.7V$ (30mA to 100 μ A with a supply of 5.5V), see Read Mode DC Characteristics Table for details. The M27W201 is placed in the standby mode by applying a CMOS high signal to the \bar{E} input. When in the standby mode, the outputs are in a high impedance state, independent of the \bar{G} input.

Two Line Output Control

Because OTP ROMs are usually used in larger memory arrays, this product features a 2 line control function which accommodates the use of multiple memory connection. The two line control function allows:

a. the lowest possible memory power dissipation,
b. complete assurance that output bus contention will not occur.

- the lowest possible memory power dissipation,
- complete assurance that output bus contention will not occur.

For the most efficient use of these two control lines, \bar{E} should be decoded and used as the primary device selecting function, while \bar{G} should be made a common connection to all devices in the array and connected to the \overline{READ} line from the system control bus. This ensures that all deselected memory devices are in their low power standby mode and that the output pins are only active when data is required from a particular memory device.

System Considerations

The power switching characteristics of Advanced CMOS OTP ROMs require careful decoupling of the devices. The supply current, I_{CC} , has three segments that are of interest to the system designer: the standby current level, the active current level, and transient current peaks that are produced by the falling and rising edges of \bar{E} . The magnitude of the transient current peaks is dependent on the capacitive and inductive loading of the device at the output.

Table 3. Operating Modes

Mode	\bar{E}	\bar{G}	\bar{P}	A9	V_{PP}	Q0 - Q7
Read	V_{IL}	V_{IL}	X	X	V_{CC} or V_{SS}	Data Out
Output Disable	V_{IL}	V_{IH}	X	X	V_{CC} or V_{SS}	Hi-Z
Program	V_{IL}	V_{IH}	V_{IL} Pulse	X	V_{PP}	Data In
Verify	V_{IL}	V_{IL}	V_{IH}	X	V_{PP}	Data Out
Program Inhibit	V_{IH}	X	X	X	V_{PP}	Hi-Z
Standby	V_{IH}	X	X	X	V_{CC} or V_{SS}	Hi-Z
Electronic Signature	V_{IL}	V_{IL}	V_{IH}	V_{ID}	V_{CC}	Codes

Note: X = V_{IH} or V_{IL} , $V_{ID} = 12V \pm 0.5V$

Table 4. Electronic Signature

Identifier	A0	Q7	Q6	Q5	Q4	Q3	Q2	Q1	Q0	Hex Data
Manufacturer's Code	V_{IL}	0	0	1	0	0	0	0	0	20h
Device Code	V_{IH}	0	1	1	0	0	0	0	1	61h

AC MEASUREMENT CONDITIONS

Input Rise and Fall Times $\leq 20\text{ns}$
 Input Pulse Voltages 0.4 to 2.4V
 Input and Output Timing Ref. Voltages 0.8 to 2.0V

Note that Output Hi-Z is defined as the point where data is no longer driven.

Figure 3. AC Testing Input Output Waveforms

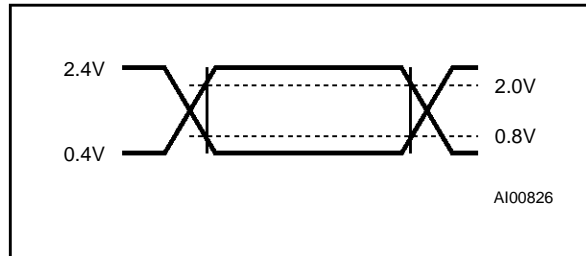

Figure 4. AC Testing Load Circuit

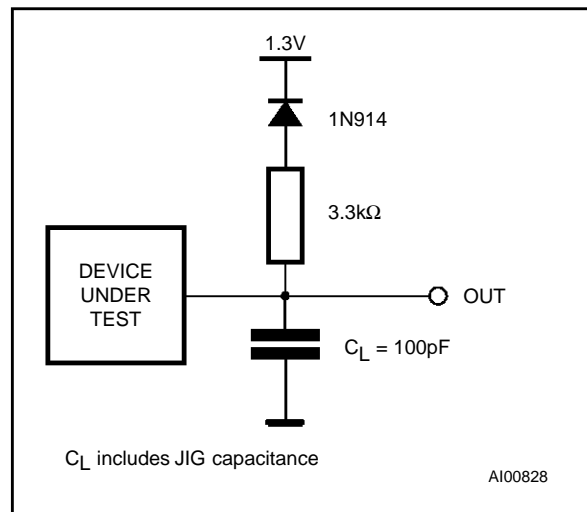

Table 5. Capacitance⁽¹⁾ ($T_A = 25\text{ }^\circ\text{C}$, $f = 1\text{ MHz}$)

Symbol	Parameter	Test Condition	Min	Max	Unit
C_{IN}	Input Capacitance	$V_{IN} = 0V$		6	pF
C_{OUT}	Output Capacitance	$V_{OUT} = 0V$		12	pF

Note: 1. Sampled only, not 100% tested.

Table 6. Read Mode DC Characteristics⁽¹⁾

($T_A = -20\text{ to }70\text{ }^\circ\text{C}$; $V_{CC} = 2.7V\text{ to }5.5V$ unless specified; $V_{PP} = V_{CC}$)

Symbol	Parameter	Test Condition	Min	Max	Unit
I_{LI}	Input Leakage Current	$0V \leq V_{IN} \leq V_{CC}$		± 10	μA
I_{LO}	Output Leakage Current	$0V \leq V_{OUT} \leq V_{CC}$		± 10	μA
I_{CC}	Supply Current	$\bar{E} = V_{IL}, \bar{G} = V_{IL}, I_{OUT} = 0mA, f = 5MHz, V_{CC} = 2.7V$		15	mA
		$\bar{E} = V_{IL}, \bar{G} = V_{IL}, I_{OUT} = 0mA, f = 5MHz, V_{CC} = 5.5V$		30	mA
I_{CC1}	Supply Current (Standby) TTL	$\bar{E} = V_{IH}$		1	mA
I_{CC2}	Supply Current (Standby) CMOS	$\bar{E} > V_{CC} - 0.2V, V_{CC} = 2.7V$		20	μA
		$\bar{E} > V_{CC} - 0.2V, V_{CC} = 5.5V$		100	μA
I_{PP}	Program Current	$V_{PP} = V_{CC}$		10	μA
V_{IL}	Input Low Voltage		-0.3	0.8	V
$V_{IH}^{(2)}$	Input High Voltage		2	$V_{CC} + 1$	V
V_{OL}	Output Low Voltage	$I_{OL} = 2.1mA$		0.4	V
V_{OH}	Output High Voltage TTL	$I_{OH} = -400\mu A$	2.4		V
	Output High Voltage CMOS	$I_{OH} = -100\mu A$	$V_{CC} - 0.7V$		V

Notes: 1. V_{CC} must be applied simultaneously with or before V_{PP} and removed simultaneously or after V_{PP} .
 2. Maximum DC voltage on Output is $V_{CC} + 0.5V$.

Table 7. Read Mode AC Characteristics⁽¹⁾(T_A = -20 to 70 °C; V_{CC} = 2.7V to 5.5V unless specified; V_{PP} = V_{CC})

Symbol	Alt	Parameter	Test Condition	M27W201				Unit
				-150		-200		
				Min	Max	Min	Max	
t _{AVQV}	t _{ACC}	Address Valid to Output Valid	$\bar{E} = V_{IL}, \bar{G} = V_{IL}$		150		200	ns
t _{ELQV}	t _{CE}	Chip Enable Low to Output Valid	$\bar{G} = V_{IL}$		150		200	ns
t _{GLQV}	t _{OE}	Output Enable Low to Output Valid	$\bar{E} = V_{IL}$		75		100	ns
t _{EHQZ} ⁽²⁾	t _{DF}	Chip Enable High to Output Hi-Z	$\bar{G} = V_{IL}$	0	70	0	80	ns
t _{GHQZ} ⁽²⁾	t _{DF}	Output Enable High to Output Hi-Z	$\bar{E} = V_{IL}$	0	70	0	80	ns
t _{AXQX}	t _{OH}	Address Transition to Output Transition	$\bar{E} = V_{IL}, \bar{G} = V_{IL}$	0		0		ns

Notes: 1. V_{CC} must be applied simultaneously with or before V_{PP} and removed simultaneously or after V_{PP}.
 2. Sampled only, not 100% tested.

Figure 5. Read Mode AC Waveforms

Table 8. Programming Mode DC Characteristics ⁽¹⁾
 ($T_A = 25\text{ }^\circ\text{C}$; $V_{CC} = 6.25\text{V} \pm 0.25\text{V}$; $V_{PP} = 12.75\text{V} \pm 0.25\text{V}$)

Symbol	Parameter	Test Condition	Min	Max	Unit
I_{LI}	Input Leakage Current	$V_{IL} \leq V_{IN} \leq V_{IH}$		± 10	μA
I_{CC}	Supply Current			50	mA
I_{PP}	Program Current	$\bar{E} = V_{IL}$		50	mA
V_{IL}	Input Low Voltage		-0.3	0.8	V
V_{IH}	Input High Voltage		2	$V_{CC} + 0.5$	V
V_{OL}	Output Low Voltage	$I_{OL} = 2.1\text{mA}$		0.4	V
V_{OH}	Output High Voltage TTL	$I_{OH} = -400\mu\text{A}$	2.4		V
V_{ID}	A9 Voltage		11.5	12.5	V

Note: 1. V_{CC} must be applied simultaneously with or before V_{PP} and removed simultaneously or after V_{PP} .

Table 9. Programming Mode AC Characteristics ⁽¹⁾
 ($T_A = 25\text{ }^\circ\text{C}$; $V_{CC} = 6.25\text{V} \pm 0.25\text{V}$; $V_{PP} = 12.75\text{V} \pm 0.25\text{V}$)

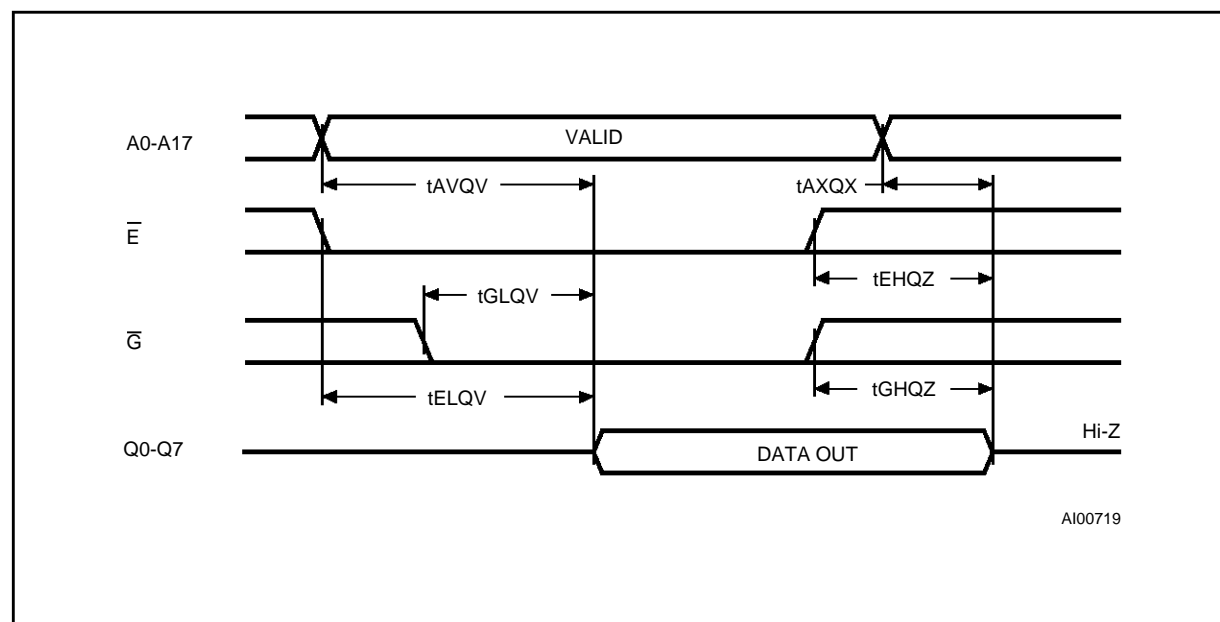
Symbol	Alt	Parameter	Test Condition	Min	Max	Unit
t_{AVPL}	t_{AS}	Address Valid to Program Low		2		μs
t_{QVPL}	t_{DS}	Input Valid to Program Low		2		μs
t_{VPHPL}	t_{VPS}	V_{PP} High to Program Low		2		μs
t_{VCHPL}	t_{VCS}	V_{CC} High to Program Low		2		μs
t_{ELPL}	t_{CES}	Chip Enable Low to Program Low		2		μs
t_{PLPH}	t_{PW}	Program Pulse Width		95	105	μs
t_{PHQX}	t_{DH}	Program High to Input Transition		2		μs
t_{QXGL}	t_{OES}	Input Transition to Output Enable Low		2		μs
t_{GLQV}	t_{OE}	Output Enable Low to Output Valid			100	ns
$t_{GHQZ}^{(2)}$	t_{DFP}	Output Enable High to Output Hi-Z		0	130	ns
t_{GHAX}	t_{AH}	Output Enable High to Address Transition		0		ns

Notes: 1. V_{CC} must be applied simultaneously with or before V_{PP} and removed simultaneously or after V_{PP} .
 2. Sampled only, not 100% tested.

Figure 6. Programming and Verify Modes AC Waveforms

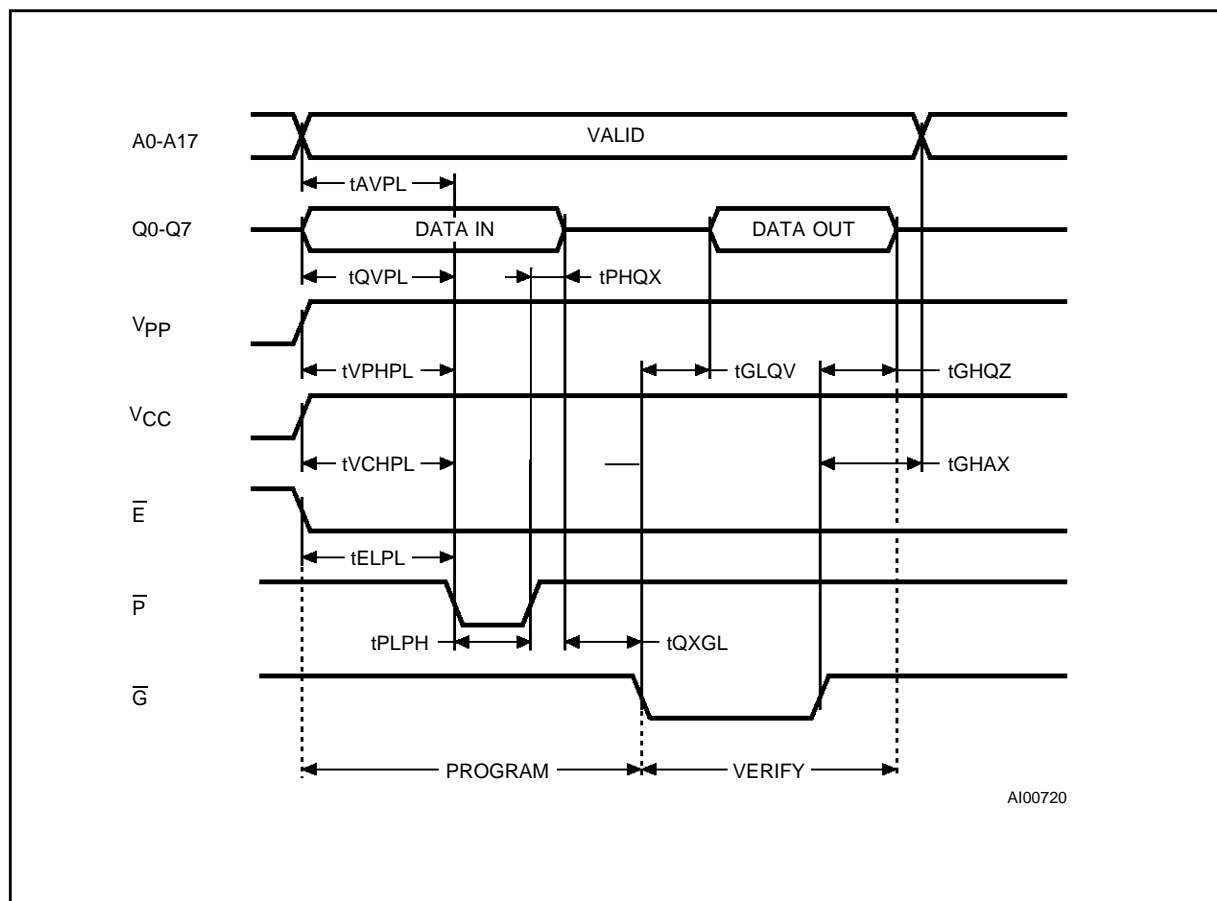

DEVICE OPERATION (cont'd)

The associated transient voltage peaks can be suppressed by complying with the two line output control and by properly selected decoupling capacitors. It is recommended that a 0.1 μ F ceramic capacitor be used on every device between V_{CC} and V_{SS} . This should be a high frequency capacitor of low inherent inductance and should be placed as close to the device as possible. In addition, a 4.7 μ F bulk electrolytic capacitor should be used between V_{CC} and V_{SS} for every eight devices. The bulk capacitor should be located near the power supply connection point. The purpose of the bulk capacitor is to overcome the voltage drop caused by the inductive effects of PCB traces.

Programming

The M27W201 has been designed to be fully compatible with the M27C2001. As a result the M27W201 can be programmed as the M27C2001 on the same programmers applying 12.75V on V_{PP} and 6.25V on V_{CC} . The M27W201 has the same electronic signature and uses the same PRESTO II algorithm.

When delivered, all bits of the M27W201 are in the "1" state. Data is introduced by selectively programming "0s" into the desired bit locations. Although only "0s" will be programmed, both "1s" and "0s" can be present in the data word. The M27W201 is in the programming mode when V_{PP} input is at 12.75V, and \bar{E} and \bar{P} are at TTL-low. The data to be programmed is applied 8 bits in parallel to the data output pins. The levels required for the address and data inputs are TTL. V_{CC} is specified to be 6.25V \pm 0.25V.

Figure 7. Programming Flowchart

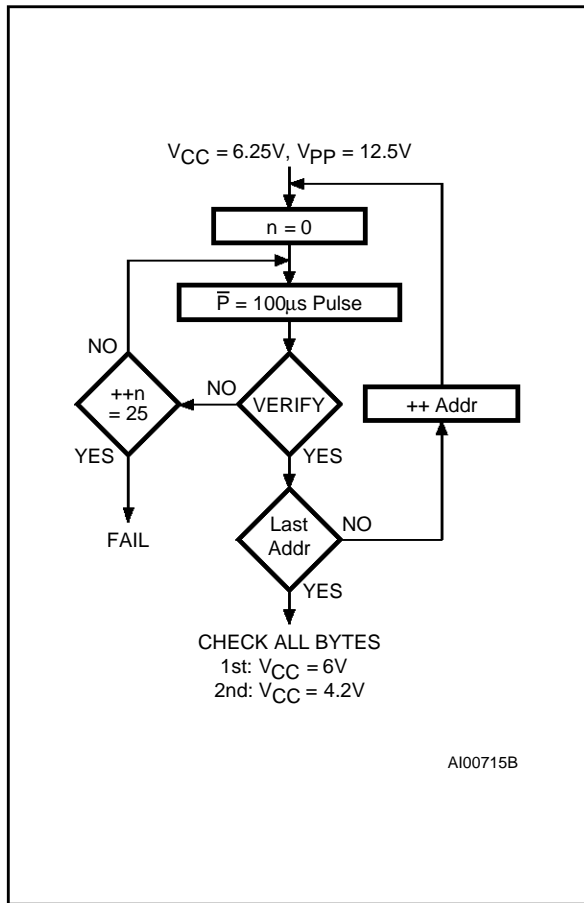

PRESTO II Programming Algorithm

PRESTO II Programming Algorithm allows the whole array to be programmed, with a guaranteed margin, in a typical time of 26.5 seconds. Programming with PRESTO II involves in applying a sequence of 100µs program pulses to each byte until a correct verify occurs. During programming and verify operation, a MARGIN MODE circuit is automatically activated in order to guarantee that each

cell is programmed with enough margin. No over-program pulse is applied since the verify in MARGIN MODE provides necessary margin to each programmed cell.

Program Inhibit

Programming of multiple M27W201s in parallel with different data is also easily accomplished. Except for \bar{E} , all like inputs including \bar{G} of the parallel M27W201 may be common. A TTL low level pulse applied to a M27W201's \bar{E} input, with P low and V_{PP} at 12.75V, will program that M27W201. A high level \bar{E} input inhibits the other M27W201s from being programmed.

Program Verify

A verify (read) should be performed on the programmed bits to determine that they were correctly programmed. The verify is accomplished with \bar{E} and \bar{G} at V_{IL} , \bar{P} at V_{IH} , V_{PP} at 12.75V and V_{CC} at 6.25V.

Electronic Signature

The Electronic Signature mode allows the reading out of a binary code that will identify its manufacturer and type. This mode is intended for use by programming equipment to automatically match the device to be programmed with its corresponding programming algorithm. This mode is functional in the $25^{\circ}\text{C} \pm 5^{\circ}\text{C}$ ambient temperature range that is required when programming the M27W201. To activate this mode, the programming equipment must force 11.5V to 12.5V on address line A9 of the M27W201, with $V_{PP} = V_{CC} = 5V$. Two identifier bytes may then be sequenced from the device outputs by toggling address line A0 from V_{IL} to V_{IH} . All other address lines must be held at V_{IL} during Electronic Signature mode.

Byte 0 ($A0=V_{IL}$) represents the manufacturer code and byte 1 ($A0=V_{IH}$) the device identifier code. For the SGS-THOMSON M27W201, these two identifier bytes are given in Table 4 and can be read-out on outputs Q0 to Q7. Note that the M27W201, M27V201 and M27C2001 have the same identifier bytes.

ORDERING INFORMATION SCHEME

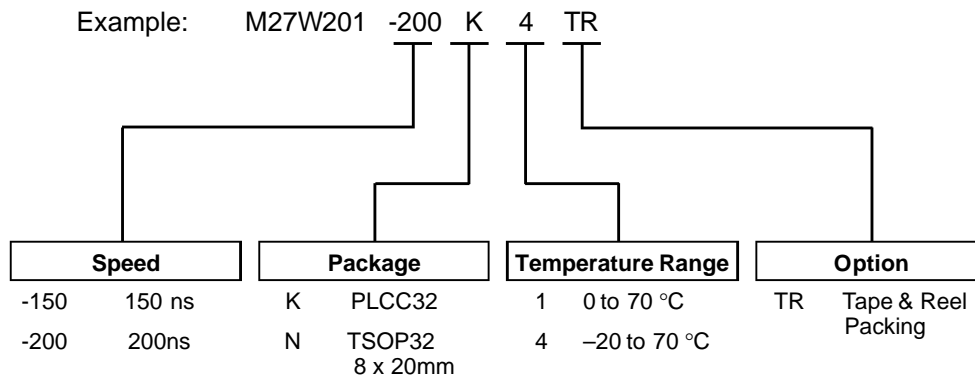

For a list of available options (Speed, Package, Temperature Range, etc...) refer to the current Memory Shortform catalogue.

For further information on any aspect of this device, please contact SGS-THOMSON Sales Office nearest to you.

PLCC32 - 32 lead Plastic Leaded Chip Carrier, rectangular

Symb	mm			inches		
	Typ	Min	Max	Typ	Min	Max
A		2.54	3.56		0.100	0.140
A1		1.52	2.41		0.060	0.095
B		0.33	0.53		0.013	0.021
B1		0.66	0.81		0.026	0.032
D		12.32	12.57		0.485	0.495
D1		11.35	11.56		0.447	0.455
D2		9.91	10.92		0.390	0.430
E		14.86	15.11		0.585	0.595
E1		13.89	14.10		0.547	0.555
E2		12.45	13.46		0.490	0.530
e	1.27	-	-	0.050	-	-
N		32			32	
Nd		7			7	
Ne		9			9	
CP			0.10			0.004

PLCC32

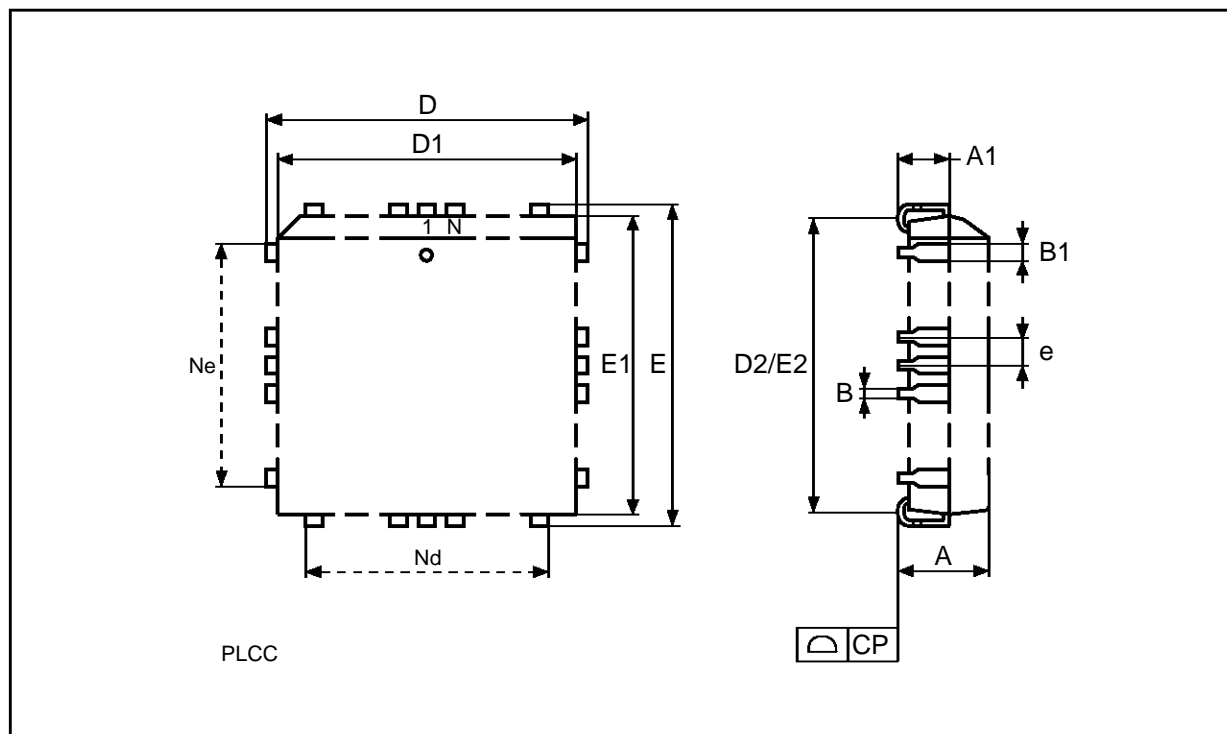

Drawing is not to scale

TSOP32 - 32 lead Plastic Thin Small Outline, 8 x 20mm

Symb	mm			inches		
	Typ	Min	Max	Typ	Min	Max
A			1.20			0.047
A1		0.05	0.17		0.002	0.006
A2		0.95	1.50		0.037	0.059
B		0.15	0.27		0.006	0.011
C		0.10	0.21		0.004	0.008
D		19.80	20.20		0.780	0.795
D1		18.30	18.50		0.720	0.728
E		7.90	8.10		0.311	0.319
e	0.50	–	–	0.020	–	–
L		0.50	0.70		0.020	0.028
α		0°	5°		0°	5°
N	32			32		
CP			0.10			0.004

TSOP32

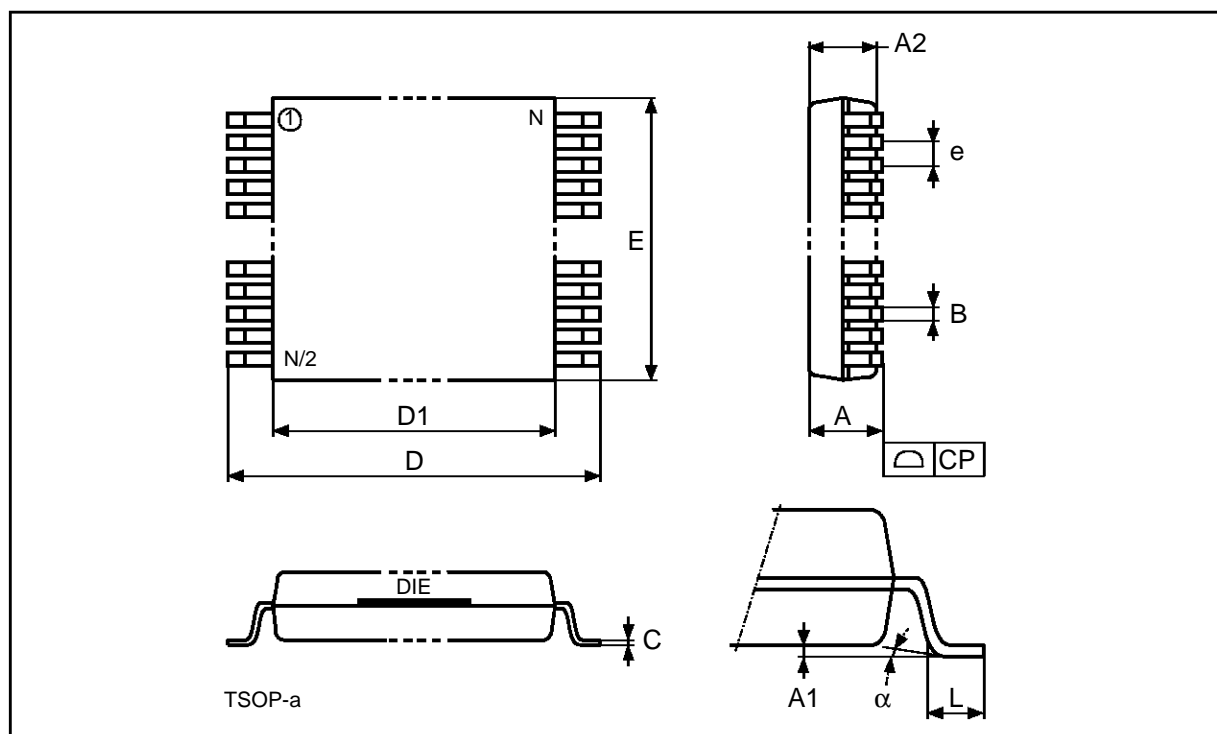

Drawing is not to scale

Information furnished is believed to be accurate and reliable. However, SGS-THOMSON Microelectronics assumes no responsibility for the consequences of use of such information nor for any infringement of patents or other rights of third parties which may result from its use. No license is granted by implication or otherwise under any patent or patent rights of SGS-THOMSON Microelectronics. Specifications mentioned in this publication are subject to change without notice. This publication supersedes and replaces all information previously supplied. SGS-THOMSON Microelectronics products are not authorized for use as critical components in life support devices or systems without express written approval of SGS-THOMSON Microelectronics.

© 1995 SGS-THOMSON Microelectronics - All Rights Reserved

SGS-THOMSON Microelectronics GROUP OF COMPANIES
Australia - Brazil - China - France - Germany - Hong Kong - Italy - Japan - Korea - Malaysia - Malta - Morocco - The Netherlands -
Singapore - Spain - Sweden - Switzerland - Taiwan - Thailand - United Kingdom - U.S.A.