



# M4Z28-BR00SH M4Z32-BR00SH

## ZEROPOWER<sup>®</sup> SNAPHAT<sup>®</sup> (Battery)

### FEATURES SUMMARY

- PROVIDES BATTERY BACKUP POWER FOR NON-VOLATILE ZEROPOWER and SUPERVISOR DEVICES IN THE 28-PIN SNAPHAT SOIC PACKAGE
- REMOVABLE BATTERY AVOIDS HEAT ASSOCIATED WITH SURFACE-MOUNT PROCESS
- SNAPS DIRECTLY ONTO SURFACE-MOUNTED SNAPHAT SOIC
- CHOICE OF BATTERY CAPACITIES
  - M4Z28-BR00SH = 48mAh
  - M4Z32-BR00SH = 120mAh
- KEYED INSERTION TO INSURE PROPER ASSEMBLY
- REMOVABLE FOR REPLACEMENT and PROPER DISPOSAL
- AVAILABLE IN TUBES OR TAPE & REEL

Figure 1. SNAPHAT Top Package

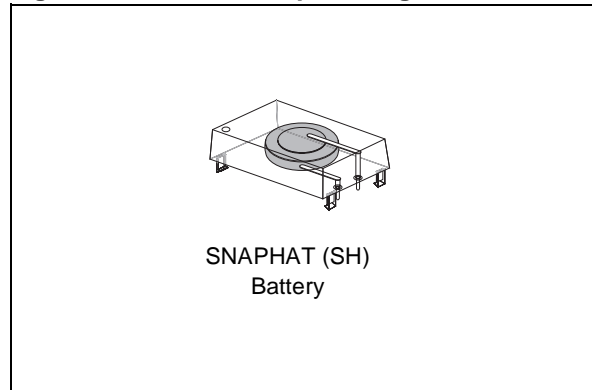

**TABLE OF CONTENTS**

**SUMMARY DESCRIPTION** ..... **3**  
    Logic Diagram (Figure 2.) ..... 3  
    Signal Names (Table 1.) ..... 3

**MAXIMUM RATING** ..... **4**  
    Absolute Maximum Ratings (Table 2.) ..... 4

**DC AND AC PARAMETERS** ..... **4**  
    Operating and AC Measurement Conditions (Table 3.) ..... 4

**MECHANICAL INFORMATION** ..... **5**  
    SNAPHAT Insertion/Extraction Forces (Figure 3.) ..... 5  
    Battery Characteristics ..... 6  
    UL Recognition ..... 6  
    Battery Life ..... 6  
    General Notes ..... 6  
    Battery Discharge Rates (Figure 4.) ..... 6  
    DIP Extractor Tool (Figure 5.) ..... 6

**PART NUMBERING** ..... **7**

**PACKAGE MECHANICAL INFORMATION** ..... **8**

**REVISION HISTORY** ..... **10**

**SUMMARY DESCRIPTION**

The M4ZXX-BR00SH SNAPHAT<sup>®</sup> top is a detachable lithium power source for ST's non-volatile ZEROPOWER<sup>®</sup> surface-mount SOIC (MH) package (28-pin).

The SNAPHAT top contains a lithium battery and is designed to be "snapped on" after the SOIC is surface mounted on the PC board. The two-piece solution prevents the battery from being exposed to the high temperatures of the surface mount process.

**Figure 2. Logic Diagram**

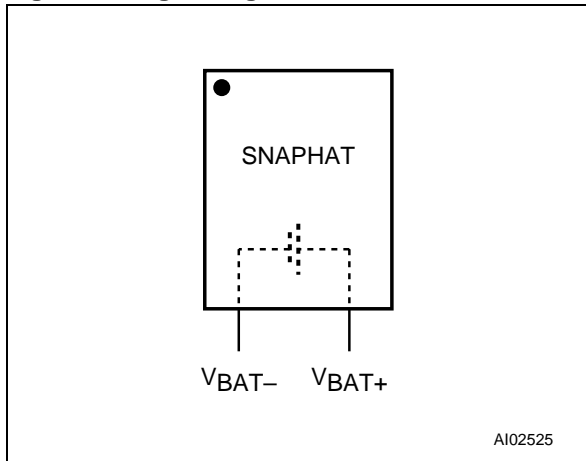

**Table 1. Signal Names**

V <sub>BAT-</sub>	Negative Voltage
V <sub>BAT+</sub>	Positive Voltage

**MAXIMUM RATING**

Stressing the device above the rating listed in the “Absolute Maximum Ratings” table may cause permanent damage to the device. These are stress ratings only and operation of the device at these or any other conditions above those indicated in the Operating sections of this specification is

not implied. Exposure to Absolute Maximum Rating conditions for extended periods may affect device reliability. Refer also to the STMicroelectronics SURE Program and other relevant quality documents.

**Table 2. Absolute Maximum Ratings**

Symbol	Parameter	Value	Unit
T <sub>A</sub>	Ambient Operating Temperature	-40 to 85	°C
T <sub>STG</sub>	Storage Temperature (V <sub>CC</sub> Off, Oscillator Off)	-40 to 85	°C

**CAUTION:** Do NOT wave solder SOIC to avoid damaging SNAPHAT sockets.

**DC AND AC PARAMETERS**

This section summarizes the operating and measurement conditions, as well as the DC and AC characteristics of the device. The parameters in the following DC and AC Characteristic tables are derived from tests performed under the Measure-

ment Conditions listed in the relevant tables. Designers should check that the operating conditions in their projects match the measurement conditions when using the quoted parameters.

**Table 3. Operating and AC Measurement Conditions**

Parameter	M4Z28-BR00SH	M4Z32-BR00SH	Unit
Nominal Battery Voltage (V <sub>CC</sub> )	2.8	2.8	V
Nominal Battery Capacity	48	120	mAh
Battery Chemistry	Li(CF)	Li(CF)	

### MECHANICAL INFORMATION

Electrical connection to the SOIC is made through two pins that connect to the press fitted sockets at one end of the SOIC. Critical contact points between the pins and sockets are gold-plated to resist oxidation. Internally, each socket contains six independent contact fingers to form redundant connections between the two components. These sockets were designed to provide high point contact force to provide the lowest possible contact resistance. The SNAPHAT<sup>®</sup> top also incorporates four molded-in retaining clips which hold onto the ends of the SOIC insuring mechanical and electrical connection even under severe mechanical shock and vibration. The combined SOIC and SNAPHAT assembly can sustain shock levels in

excess of 100 g without separating. This package also passes variable frequency testing in accordance with MIL-STD-883, method 2007.2, condition A.

Figure 3 illustrates the affect of repeated insertion and extraction of the SNAPHAT top to the SOIC. The force required to extract the SNAPHAT, and then to re-insert it, reduces each time. After three or four extractions, though, the reduction starts to become unnoticeable, and the force required remains at a fairly constant figure. Typically, though, the SNAPHAT will only need to be extracted and re-inserted once in its lifetime.

Figure 3. SNAPHAT Insertion/Extraction Forces

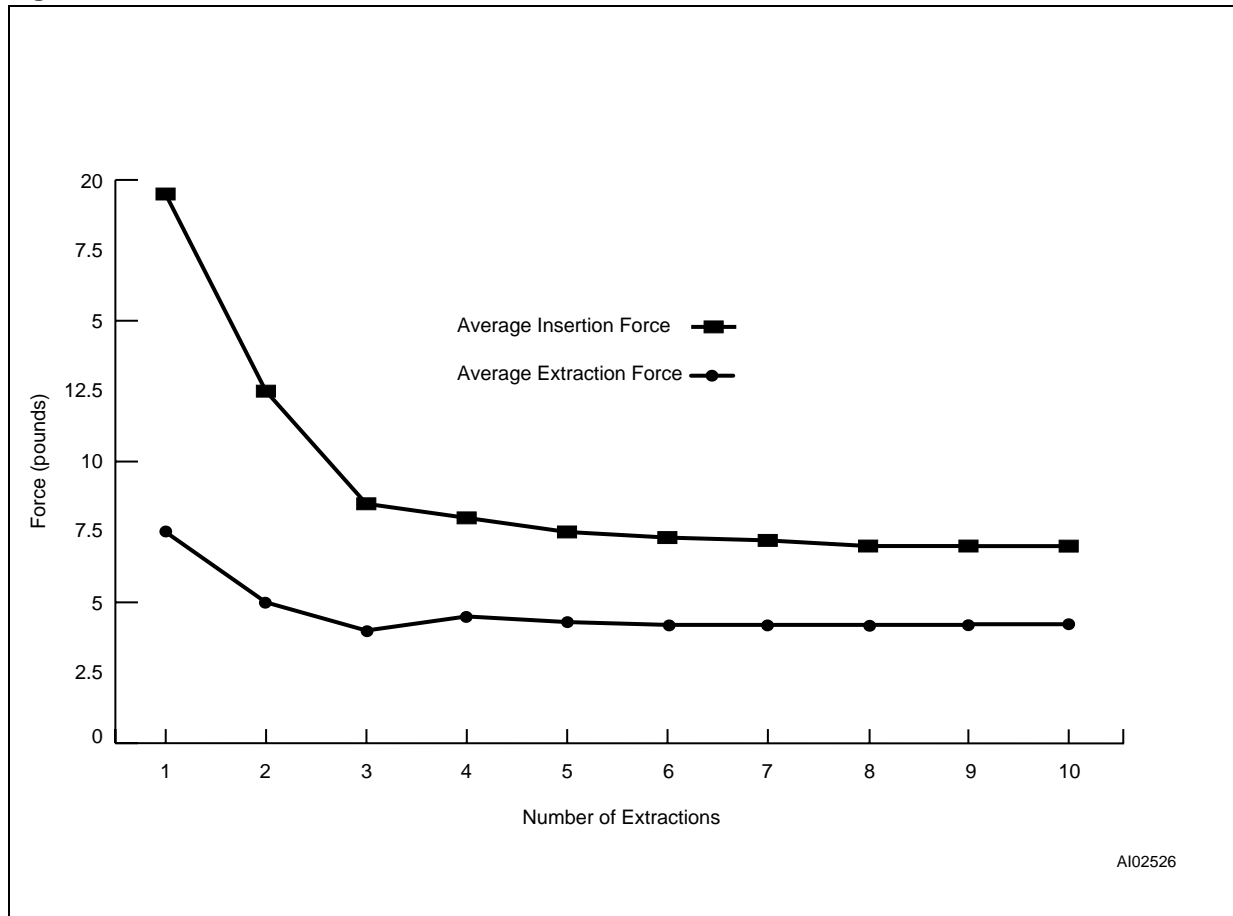

**Battery Characteristics**

Figure 4 illustrates the lithium coin cell discharge rate for a given load. This demonstrates the characteristically flat voltage level supplied by the battery until very near the end of its life. These discharge levels have been greatly accelerated in comparison to the normal, actual usage.

**UL Recognition**

The M4ZXX-BR00SH has been recognized by Underwriters Laboratories under their Component Recognition Program and carries U.L. File Number E89556.

**Battery Life**

For information on Data Retention Life and Battery Storage Life, please refer to the Application Note AN1012.

**General Notes**

To remove the SNAPHAT® top for replacement, a DIP/IC extractor tool should be used (see Figure 5). The SNAPHAT top should be grabbed by the narrow end to avoid bending the pins.

**Caution:** To avoid draining battery do NOT place SNAPHAT pins into conductive foam.

**Figure 4. Battery Discharge Rates**

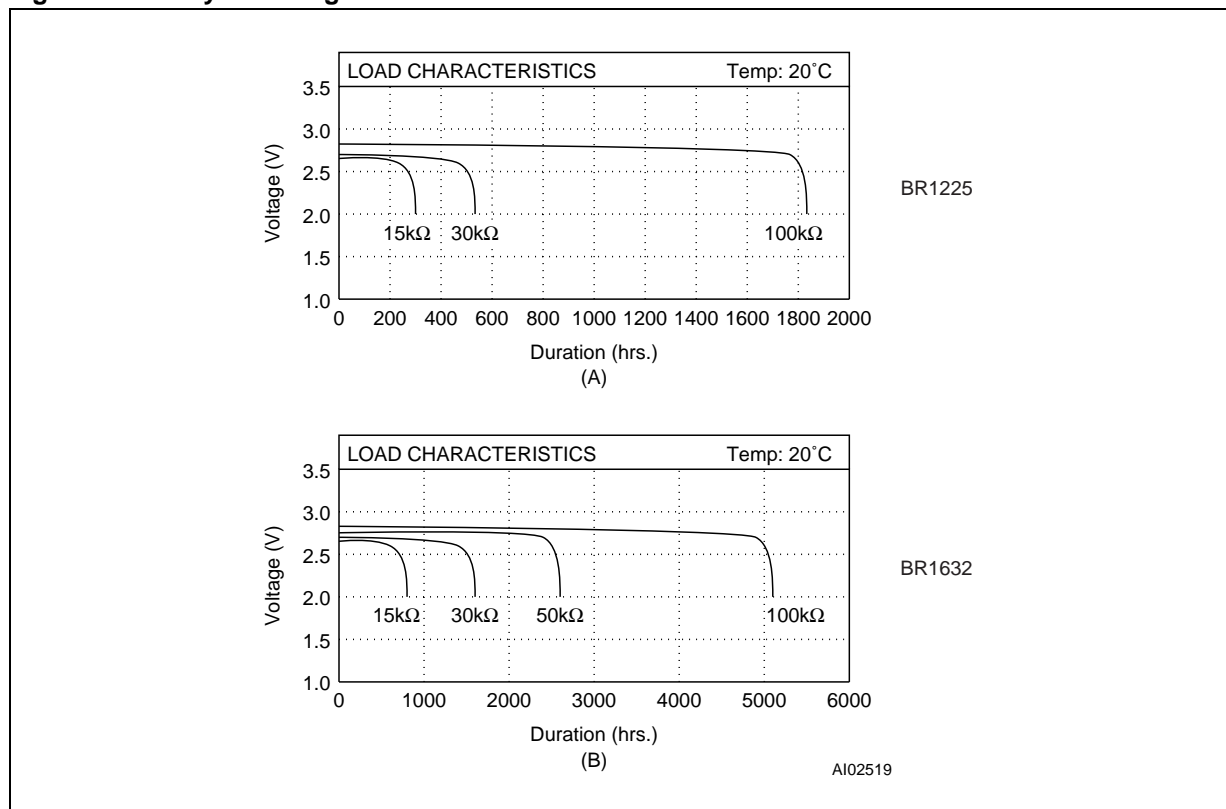

**Figure 5. DIP Extractor Tool**

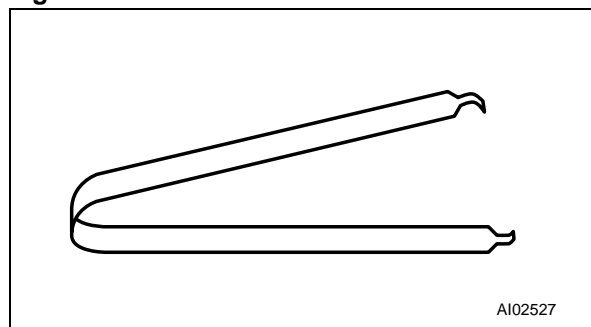

**PART NUMBERING**

**Table 4. Ordering Information Scheme**

Example:	M4Z	28-BR00	SH	1	TR
<b>Device Type</b>					
M4Z					
<b>Battery Voltage and Capacity</b>					
28-BR00 = BR1225, 3V, 48mAh					
32-BR00 = BR1632, 3V, 120mAh					
<b>Package</b>					
SH = SNAPHAT®					
<b>Temperature Range</b>					
1 = -40 to 85°C					
<b>Shipping Method</b>					
blank = Tubes					
TR = Tape & Reel					

For a list of available options (e.g., Speed, Package) or for further information on any aspect of this device, please contact the ST Sales Office nearest to you.

PACKAGE MECHANICAL INFORMATION

Figure 6. SH – 4-pin SNAPHAT Housing for 48mAh Battery Package Outline

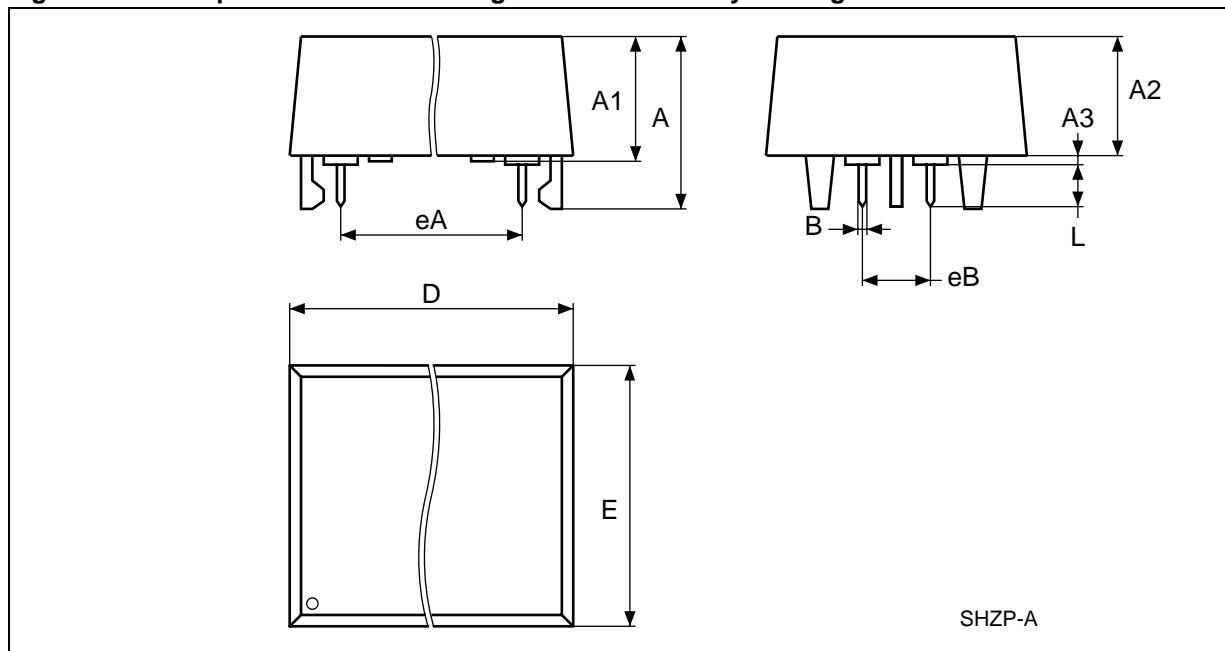

Note: Drawing is not to scale.

Table 5. SH – 4-pin SNAPHAT Housing for 48mAh Battery Package Mechanical Data

Symb	mm			inches		
	Typ	Min	Max	Typ	Min	Max
A			9.78			0.385
A1		6.73	7.24		0.265	0.285
A2		6.48	6.99		0.255	0.275
A3			0.38			0.015
B		0.46	0.56		0.018	0.022
D		21.21	21.84		0.835	0.860
E		14.22	14.99		0.560	0.590
eA		15.55	15.95		0.612	0.628
eB		3.20	3.61		0.126	0.142
L		2.03	2.29		0.080	0.090

Figure 7. SH – 4-pin SNAPHAT Housing for 120mAh Battery Package Outline

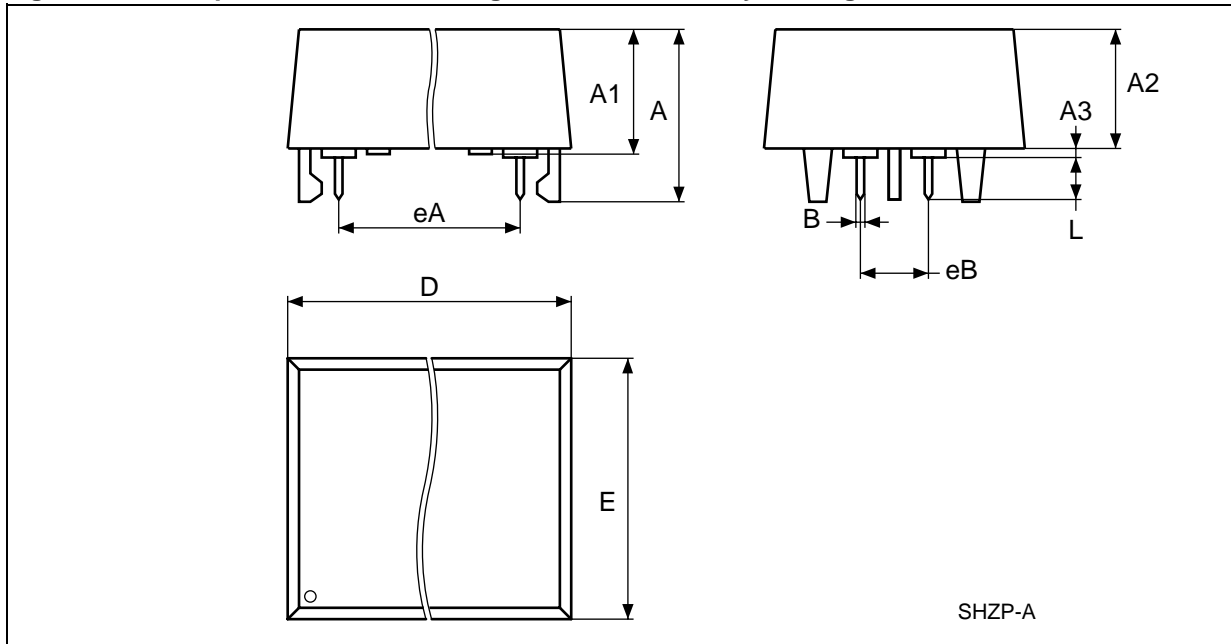

Note: Drawing is not to scale.

Table 6. SH – 4-pin SNAPHAT Housing for 120mAh Battery Package Mechanical Data

Symb	mm			inches		
	Typ	Min	Max	Typ	Min	Max
A			10.54			0.415
A1		8.00	8.51		0.315	0.335
A2		7.24	8.00		0.285	0.315
A3			0.38			0.015
B		0.46	0.56		0.018	0.022
D		21.21	21.84		0.835	0.860
E		17.27	18.03		0.680	0.710
eA		15.55	15.95		0.612	0.628
eB		3.20	3.61		0.126	0.142
L		2.03	2.29		0.080	0.090

**REVISION HISTORY**

**Table 7. Document Revision History**

<b>Date</b>	<b>Revision Details</b>
November 1999	First Issue
05/29/01	Reformatted
06/04/01	Basic textual changes from reformatting activity
07/10/01	Remove references to "Crystal;" change references to "SUPERVISOR" from Controller; clarify temperature characteristics

Information furnished is believed to be accurate and reliable. However, STMicroelectronics assumes no responsibility for the consequences of use of such information nor for any infringement of patents or other rights of third parties which may result from its use. No license is granted by implication or otherwise under any patent or patent rights of STMicroelectronics. Specifications mentioned in this publication are subject to change without notice. This publication supersedes and replaces all information previously supplied. STMicroelectronics products are not authorized for use as critical components in life support devices or systems without express written approval of STMicroelectronics.

The ST logo is registered trademark of STMicroelectronics  
All other names are the property of their respective owners.

© 2001 STMicroelectronics - All Rights Reserved

STMicroelectronics GROUP OF COMPANIES  
Australia - Brazil - China - Finland - France - Germany - Hong Kong - India - Italy - Japan - Malaysia - Malta - Morocco -  
Singapore - Spain - Sweden - Switzerland - United Kingdom - U.S.A.

[www.st.com](http://www.st.com)