

MITSUBISHI ICs (VCR)
M52359FP

4-CHANNEL RECORDING AND PLAYBACK AMPLIFIER FOR VCR

DESCRIPTION

The M52359FP is a semiconductor integrated circuit is used with camera-integrated video cassette recorders. A single chip serves as an amplifier during both recording and playback. The circuit consists of a recording Y/C mixer, four-head current amplifier for recording, playback amplifier, playback chroma amplifier, FM automatic gain control, four-head switching circuit, mute circuit, EP/SP switching circuit, crosstalk transistor control circuit, and envelope detector.

FEATURES

- To diminish power dissipation, this IC works with low-voltage power supplies (5.0V and 3.3V). It can also be used with a single 5.0V supply.
- A crosstalk preventing transistor control circuit is built in, reducing the number of external elements. With this control circuit, channel switching errors are prevented by controlling the pulse switch waveform.
- 4 channels are controlled with 3 lines : FF30, FF15 and overlap pulse. This arrangement reduces the number of required control lines.
- For recording output, the current gain and idle current can be adjusted by connecting external resistance to the constant-current drive.
- Playback amplifier features improved C/N characteristics.
- A wide-band amplifier is provided to enable application to S-VHS VCRs.
- Audio trap terminal is provided. Its setting is "normal" during playback.

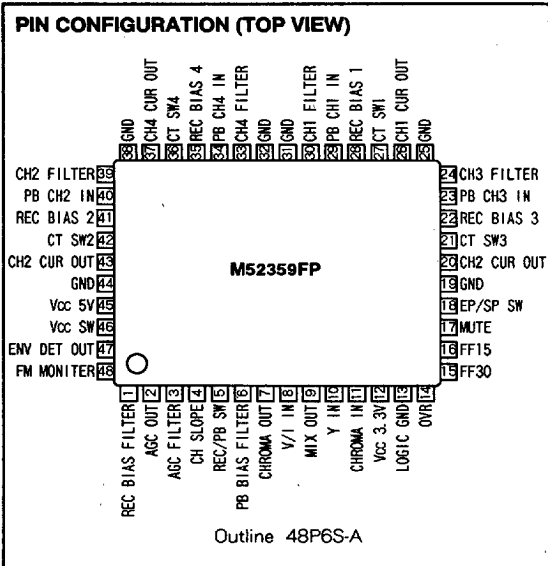

Outline 48P6S-A

APPLICATION

Video cameras

RECOMMENDED OPERATING CONDITION

Supply voltage range..... 5 ± 0.2V, 3.3 ± 0.1V
 Rated supply voltage..... 5V, 3.3 or 5.0V

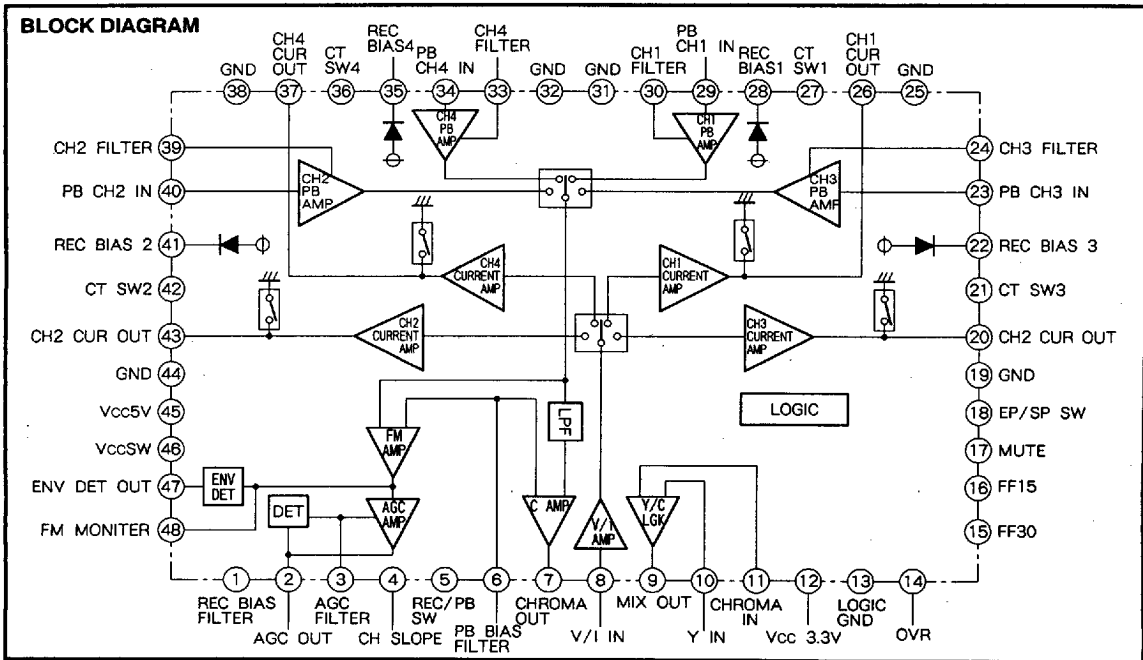

6249826 0023000 2T0



4-CHANNEL RECORDING AND PLAYBACK AMPLIFIER FOR VCR

ABSOLUTE MAXIMUM RATINGS (Ta = 25°C, unless otherwise noted)

Symbol	Parameter	Ratings	Unit
Vcc	Supply voltage	6.0	V
Pd	Power dissipation	1000	mW
Topr	Operating temperature	-20~75	°C
Tstg	Storage temperature	-40~125	°C
Vopr	Recommended operating voltage	5.0	V
Vopr	Operating voltage range	4.85~5.15	V

ELECTRICAL CHARACTERISTICS (Ta = 25°C, unless otherwise noted)

Pin conditions (REC mode)

REC control pin	⑤	⑫	⑭	⑮	⑯	⑰	⑱	⑳	㉑
Pin conditions	GND	----	OVR	FF15	FF30	----	----	5(V)	5(V)

OVR, FF15, FF30 = Control pulses (Refer to mode selector circuit output waveform.)

Symbol	Parameter	Test conditions and input conditions	Test circuit	Limits			Unit
				Min.	Typ.	Max.	
Icr5	REC circuit current 5V	Measure pin⑤ and pin⑥ intake	1	43	52	67	mA
I26	REC output direct current	CH1 Measure pin②⑥ output voltage	1	11	15	19	mA
I43		CH2 Measure pin④⑧ output voltage					mA
I20		CH3 Measure pin⑩⑭ output voltage					mA
I37		CH4 Measure pin⑫⑰ output voltage					mA
ΔIo	DC offset	-	1	0.0	-	2.0	mA
IR-1	REC output signal current	CH1 Measure pin②⑥	1	9	12	15	mAP-P
IR-2		CH2 Measure pin④⑧					mAP-P
IR-3		CH3 Measure pin⑩⑭					mAP-P
IR-4		CH4 Measure pin⑫⑰					mAP-P
ΔIRo	Signal current offset	-	1	0.0	-	2.0	mAP-P
fr-1	REC output frequency characteristic	CH1 Measure pin②⑥	1	-3	-1	1	dB
fr-2		CH2 Measure pin④⑧					dB
fr-3		CH3 Measure pin⑩⑭					dB
fr-4		CH4 Measure pin⑫⑰					dB
DR-1	REC output secondary distortion	CH1 Measure pin②⑥	1	-	-40	-35	dB
DR-2		CH2 Measure pin④⑧					dB
DR-3		CH3 Measure pin⑩⑭					dB
DR-4		CH4 Measure pin⑫⑰					dB
CTR1-2	REC CH1 crosstalk	CH2 Measure pin②⑥	1	-	-40	-30	dB
CTR1-3		CH3 Measure pin④⑧					dB
CTR1-4		CH4 Measure pin⑩⑭					dB
CTR2-1	REC CH2 crosstalk	CH1 Measure pin②⑥	1	-	-40	-30	dB
CTR2-3		CH3 Measure pin④⑧					dB
CTR2-4		CH4 Measure pin⑩⑭					dB
CTR3-1	REC CH3 crosstalk	CH1 Measure pin②⑥	1	-	-40	-30	dB
CTR3-2		CH2 Measure pin④⑧					dB
CTR3-4		CH4 Measure pin⑩⑭					dB
CTR4-1	REC CH4 crosstalk	CH1 Measure pin②⑥	1	-	-40	-30	dB
CTR4-2		CH2 Measure pin④⑧					dB
CTR4-3		CH3 Measure pin⑩⑭					dB
NR1	REC output noise	CH1 Measure pin②⑥	1	-	1.0	2.0	mVrms
NR2		CH2 Measure pin④⑧					mVrms
NR3		CH3 Measure pin⑩⑭					mVrms
NR4		CH4 Measure pin⑫⑰					mVrms
MR	REC mute	Measure pin②⑥	1	-	-60	-40	dB
MTH	Mute threshold	Measure pin②⑥	1	0.7	1.0	1.3	V

Note. CH1, CH2, CH3 and CH4 as in the table above each refer to a period that is specified on mode selector circuit output waveform.

6249826 0023001 137



4-CHANNEL RECORDING AND PLAYBACK AMPLIFIER FOR VCR

ELECTRICAL CHARACTERISTICS (Cont.)

Symbol	Parameter	Test conditions and input conditions	Test circuit	Limits			Unit	
				Min.	Typ.	Max.		
BR1	REC head bias	CH1 Measure pin ②	-	1	3.8	4.0	4.2	V
BR2		CH2 Measure pin ④						
BR3		CH3 Measure pin ⑥						
BR4		CH4 Measure pin ⑧						
GMY	MIX AMP GAIN	Y IN Input to pin ⑩: 5MHz CW 200mV	-	1	5.0	6.0	7.0	dB
GMC		C IN Input to pin ⑪: 1MHz CW 200mV						
fMY	MIX AMP frequency characteristic	Y IN Input to pin ⑩: 10MHz CW 200mV	-	1	-1.0	0.0	1.0	dB
fMC		C IN Input to pin ⑪: 2MHz CW 200mV						
DMY	MIX AMP secondary distortion	Y IN Input to pin ⑩: 5MHz CW 200mVP-P	-	1	-	-45	-40	dB
DMC		C IN Input to pin ⑪: 1MHz CW 200mVP-P						
VR12	REC built-in power supply	Measure pin ⑫	-	1	3.1	3.3	3.5	V
VT5	Recording/Playback threshold	Measure pin ⑮	-	1	0.7	1.0	1.3	V
VT14	OVR threshold	Measure pin ⑭	-	1	0.7	1.0	1.3	V
VT15	FF30 threshold	Measure pin ⑮	-	1	0.7	1.0	1.3	V
VT16	FF15 threshold	Measure pin ⑮	-	1	0.7	1.0	1.3	V
I27	CT Tr base current	CH1 Measure pin ⑦	-	1	0.5	0.8	1.1	mA
I42		CH2 Measure pin ④						
I21		CH3 Measure pin ⑦						
I36		CH4 Measure pin ⑧						

Note. CH1, CH2, CH3 and CH4 as in the table above each refer to a period that is specified on mode selector circuit output waveform.

Pin conditions (PB - EP mode)

PB control pin	⑤	⑫	⑭	⑮	⑰	⑱	⑳	㉑	㉒
Pin conditions	5(V)	-----	OVR	FF15	FF30	-----	5(V)	5(V)	5(V)

OVR, FF15, FF30 = Control pulses (Refer to mode selector circuit output waveform.)

Symbol	Parameter	Test conditions and input conditions	Test circuit	Limits			Unit	
				Min.	Typ.	Max.		
Icp5	PB circuit current 5V	Measure pin ⑤ and pin ⑥ intake current	1	38	48	60	mA	
VI26	PB output DC voltage	CH1	-	1	1.6	1.8	2.0	V
VI43		CH2						
VI20		CH3						
VI37		CH4						
ΔV48	DC voltage offset	-	-	1	0.0	-	0.2	V
GP-1	PB output gain	CH1 Input to pin ②	-	1	63	65	67	dB
GP-2		CH2 Input to pin ④						
GP-3		CH3 Input to pin ⑥						
GP-4		CH4 Input to pin ⑧						
ΔGPO	Output gain offset	-	-	1	0.0	-	2.0	dB
fp-1	PB output frequency characteristic	CH1 Input to pin ②	-	1	-3	-1	1	dB
fp-2		CH2 Input to pin ④						
fp-3		CH3 Input to pin ⑥						
fp-4		CH4 Input to pin ⑧						
DP-1	PB output secondary distortion	CH1 Input to pin ②	-	1	-	-45	-40	dB
DP-2		CH2 Input to pin ④						
DP-3		CH3 Input to pin ⑥						
DP-4		CH4 Input to pin ⑧						
CTP1-2	PB CH1 crosstalk	CH2	-	1	-	-40	-30	dB
CTP1-3		CH3 Input to pin ②						
CTP1-4		CH4						
CTP2-1	PB CH2 crosstalk	CH1	-	1	-	-40	-30	dB
CTP2-3		CH3 Input to pin ④						
CTP2-4		CH4						

Note. CH1, CH2, CH3 and CH4 as in the table above each refer to a period that is specified on mode selector circuit output waveform.

6249826 0023002 073



4-CHANNEL RECORDING AND PLAYBACK AMPLIFIER FOR VCR

ELECTRICAL CHARACTERISTICS (Cont.)

Symbol	Parameter		Test conditions and input conditions		Test circuit	Limits			Unit
						Min.	Typ.	Max.	
CTP3-1	PB CH3 crosstalk	CH1	Input to pin ②	Measure pin ④ Input signal: 5.0MHz CW 0.2mVp-p	1	-	-40	-30	dB
CTP3-2		CH2				-	-40	-30	
CTP3-4		CH4				-	-40	-30	
CTP4-1	PB CH4 crosstalk	CH1	Input to pin ④	Measure pin ② Input signal: 5.0MHz CW 0.2mVp-p	1	-	-40	-30	dB
CTP4-2		CH2				-	-40	-30	
CTP4-3		CH3				-	-40	-30	
NP1	PB AMP input conversion noise	CH1	Measure pin ④		1	-	-	2.0	nV/√Hz
NP2		CH2							
NP3		CH3							
NP4		CH4							
GPC1	PB chroma output gain	CH1	Input to pin ②	Measure pin ① Input signal: 1.0MHz CW 0.2mVp-p	1	64	66	68	dB
GPC2		CH2	Input to pin ④						
GPC3		CH3	Input to pin ③						
GPC4		CH4	Input to pin ④						
DPC1	PB chroma output secondary distortion	CH1	Input to pin ②	Measure pin ① Input signal: 1.0MHz CW 0.2mVp-p	1	-	-45	-40	dB
DPC2		CH2	Input to pin ④						
DPC3		CH3	Input to pin ③						
DPC4		CH4	Input to pin ④						
fPC1	PB chroma output frequency characteristic	CH1	Input to pin ②	Input signal: 2.0MHz CW 0.2mVp-p	1	-5.0	-3.0	-1.0	dB
fPC2		CH2	Input to pin ④						
fPC3		CH3	Input to pin ③						
fPC4		CH4	Input to pin ④						

(Shunt transistor control)

A27	Shunt transistor control current slope characteristic : fall	CH1	Measure pin ②	Input: OVR, FF15 and FF30 control pulses only	1	150	250	400	μs
A42		CH2	Measure pin ④						
A21		CH3	Measure pin ③						
A36		CH4	Measure pin ⑤						
B27	Shunt transistor control current slope characteristic : rise	CH1	Measure pin ②	Input: OVR, FF15 and FF30 control pulses only	1	150	250	400	μs
B42		CH2	Measure pin ④						
B21		CH3	Measure pin ③						
B36		CH4	Measure pin ⑤						

Note. CH1, CH2, CH3 and CH4 as in the table above each refer to a period that is specified on mode selector circuit output waveform.

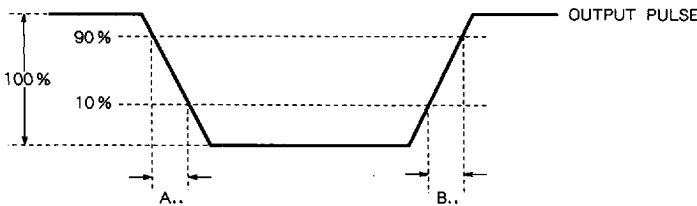

Note. For slope characteristics shunt transistor control measure the period between when the pin ②, ④, ③ or ⑤ output amplitude is 10% and when it is 90%.

6249826 0023003 TOT



4-CHANNEL RECORDING AND PLAYBACK AMPLIFIER FOR VCR

Pin conditions (PB – SP mode)

PB control pin	⑤	⑫	⑭	⑮	⑯	⑰	⑱	⑳	㉑
Pin conditions	5(V)	-----	OVR	FF15	FF30	-----	GND	5(V)	5(V)

OVR, FF15 and FF30 = Control pulses (Refer to mode selector circuit output waveform.)

Symbol	Parameter		Test conditions and input conditions		Test circuit	Limits			Unit
						Min.	Typ.	Max.	
VP12	PB built-in power supply		Measure pin⑫ voltage		1	3.1	3.3	3.5	V
VS26	PB output DC voltage		CH1	Measure pin⑳ output voltage	1	1.6	1.8	2.0	V
VS43			CH2						V
VS20			CH3						V
VS37			CH4						V
ΔV48S	DC voltage offset		-		1	0.0	-	0.2	V
GPS1	PB output gain		CH1	Input to pin㉑	1	60	62	64	dB
GPS2			CH2	Input to pin㉒					dB
GPS3			CH3	Input to pin㉓					dB
GPS4			CH4	Input to pin㉔					dB
ΔGPS	Output gain offset		-		1	0.0	-	2.0	dB
fps1	PB output frequency characteristic		CH1	Input to pin㉑	1	-3	-1	1	dB
fps2			CH2	Input to pin㉒					dB
fps3			CH3	Input to pin㉓					dB
fps4			CH4	Input to pin㉔					dB
DPS1	PB output secondary distortion		CH1	Input to pin㉑	1	-	-45	-40	dB
DPS2			CH2	Input to pin㉒					dB
DPS3			CH3	Input to pin㉓					dB
DPS4			CH4	Input to pin㉔					dB

(AGC)

VPA2	PB AGC output voltage		Measure pin⑫ DC voltage		1	1.5	1.8	2.1	V
AOUT	PB AGC signal level		Input to pin㉑ : 5MHz, 0.2mV _{P-P}		1	300	400	500	mV _{P-P}
APAX	PB AGC control range		MAX	Input to pin㉑ : 5MHz, 0.1mV _{P-P}	1	-2	0	2	dB
APIN			MIN	Input to pin㉑ : 5MHz, 0.4mV _{P-P}	1				dB
DAGI	PB AGC secondary distortion		Input to pin㉑ : 5MHz, 0.2mV _{P-P}		1	-	-45	-40	dB
NAGI	PB AGC noise		-		1	-	3.0	6.0	mV _{rms}

(ENV, DET)

ΔV47	ENV, DET detection sensitivity		Measure pin⑫ voltage		1	0.5	1.0	1.5	V/mV _{P-P}
V47H	ENV, DET detection voltage		H	Input to pin㉑ : 5MHz, 0.4mV _{P-P}	1	4.4	4.7	5.0	V
V47M			M	Input to pin㉑ : 5MHz, 0.2mV _{P-P}	1	2.0	2.3	2.6	V
V47L			L	Input to pin㉑ : 5MHz, 0.1mV _{P-P}	1	0.6	0.9	1.2	V

Note. CH1, CH2, CH3 and CH4 as in the table above each refer to a period that is specified on mode selector circuit output waveform.

6249826 0023004 946



4-CHANNEL RECORDING AND PLAYBACK AMPLIFIER FOR VCR

ELECTRICAL CHARACTERISTIC TESTING PROCEDURE

REC output DC

Measure REC output pin voltage drop caused by external resistance (100Ω).

$$I_{xx}(mA) = \frac{\text{Voltage drop caused by external resistance (100}\Omega\text{)}(mV)}{100(\Omega)}$$

DC offset

Calculate the difference between maximum and minimum among symbol I26 thru I37 measured values.

$$\Delta I_o = \text{Maximum} - \text{Minimum}$$

REC output signal current

Measure REC output pin signal voltage caused by external resistance (100Ω)

$$I_{R-x}(mA_{P-P}) = \frac{\text{Signal voltage caused by external resistance (100}\Omega\text{)} (mV_{P-P})}{100(\Omega)}$$

Output DC offset

Calculate the difference between maximum and minimum among symbol IR-1 thru IR-4 measured values.

$$\Delta I_{ro} = \text{Maximum} - \text{Minimum}$$

REC output characteristic frequency

Input 5MHz CW and 10MHz CW to pin⑩, and obtain the ratio of 10MHz amplitude to 5MHz amplitude for each REC output.

$$f_{R-n}(dB) = 20 \cdot \log \frac{10\text{MHz amplitude (mV}_{P-P}\text{)}}{5\text{MHz amplitude (mV}_{P-P}\text{)}} \quad n-1, 2, 3, 4$$

REC output secondary distortion

Calculate the ratio of 10MHz component to 5MHz component for output of each channel.

$$D_{R-n}(dB) = 20 \cdot \log \frac{5\text{MHz component (mV}_{P-P}\text{)}}{10\text{MHz component (mV}_{P-P}\text{)}} \quad n-1, 2, 3, 4$$

REC crosstalk

Calculate the ratio of OFF channel 5MHz component to ON channel 5MHz component.

$$C_{TRX-n}(dB) = 20 \cdot \log \frac{\text{OFF channel 5MHz component}}{\text{ON channel 5MHz component}}$$

REC output noise

For each channel, let output noise through 1MHz BPF, and measure it with rms voltmeter.

REC mute

For CH1, measure REC output level fluctuation that occurs when pin⑩ voltage is distributed to GND and Vcc.

MIX AMP frequency characteristic

Input 10MHz to pin⑩, or input 2MHz to pin⑪, and calculate the ratio of 10MHz component or 2MHz component to 5MHz component or 1MHz component.

MIX AMP secondary distortion

1. Calculate the ratio of 10MHz component to 5MHz component for output of each channel.

$$D_{Mx}(dB) = 20 \cdot \log \frac{5\text{MHz component (mV}_{P-P}\text{)}}{10\text{MHz component (mV}_{P-P}\text{)}} \quad n-1, 2, 3, 4$$

2. Calculate the ratio of 2MHz component to 1MHz component for output of each channel.

$$D_{Mx}(dB) = 20 \cdot \log \frac{1\text{MHz component (mV}_{P-P}\text{)}}{2\text{MHz component (mV}_{P-P}\text{)}} \quad n-1, 2, 3, 4$$

Output DC voltage offset

Calculate the difference between maximum and minimum among symbol VI26 thru VI37 measured values.

$$\Delta V_{48} = \text{Maximum} - \text{Minimum}$$

Output GAIN offset

Calculate the difference between maximum and minimum among symbol GP-1 thru GP-4 measured values.

$$\Delta G_{Po} = \text{Maximum} - \text{Minimum}$$

PB output frequency characteristic

Input 10MHz, 0.2mV_{P-P}, CW to pins⑳,㉑,㉒ and ㉓, and measure each PB output.

$$f_{P-n}(dB) = 20 \cdot \log \frac{10\text{MHz output (mV}_{P-P}\text{)}}{5\text{MHz output (mV}_{P-P}\text{)}} \quad n-1, 2, 3, 4$$

PB output secondary distortion

Measure the ratio of 10MHz component to 5MHz component for output of each channel.

$$D_{P-n}(dB) = 20 \cdot \log \frac{10\text{MHz component (mV}_{P-P}\text{)}}{5\text{MHz component (mV}_{P-P}\text{)}} \quad n-1, 2, 3, 4$$

PB crosstalk

Calculate ON channel 5MHz component and OFF channel 5MHz component to measure crosstalk

$$C_{TPX-n}(dB) = 20 \cdot \log \frac{\text{OFF channel 5MHz component}}{\text{ON channel 5MHz component}} \quad n-1, 2, 3, 4$$

PB AMP input conversion noise

Calculate by dividing output noise of each channel by amplifier GAIN.

6249826 0023005 882



4-CHANNEL RECORDING AND PLAYBACK AMPLIFIER FOR VCR

PB chroma output secondary distortion

Calculate the ratio of 2MHz component to 1MHz component for output of each channel.

$$DPC_n(\text{dB}) = 20 \cdot \log \frac{2\text{MHz component (mVP-P)}}{1\text{MHz component (mVP-P)}} \quad n=1, 2, 3, 4$$

PB chroma output frequency characteristic

Input 2MHz, 0.2mVP-P, CW to pins ③, ④, ⑤ and ⑥, and measure each PB chroma output.

$$fPC_n(\text{dB}) = 20 \cdot \log \frac{2\text{MHz output (mVP-P)}}{1\text{MHz output (mVP-P)}} \quad n=1, 2, 3, 4$$

Output DC voltage offset

Calculate the difference between maximum and minimum among symbol Vs26 thru Vs37 measured values.

$$\Delta V_{48S} = \text{Maximum} - \text{Minimum}$$

Output gain offset

Calculate the difference between maximum and minimum among measured values of symbol GPs1 thru GPs4.

$$\Delta GPs = \text{Maximum} - \text{Minimum}$$

PB output frequency characteristic

Input 10MHz, 0.2mVP-P, CW to pins ③, ④, ⑤ and ⑥, and measure each PB output.

$$fPS_n(\text{dB}) = 20 \cdot \log \frac{10\text{MHz output (mVP-P)}}{5\text{MHz output (mVP-P)}} \quad n=1, 2, 3, 4$$

PB output secondary distortion

Calculate the ratio of 10MHz component to 5MHz for output of each channel.

$$DPS_n(\text{dB}) = 20 \cdot \log \frac{10\text{MHz component (mVP-P)}}{5\text{MHz component (mVP-P)}} \quad n=1, 2, 3, 4$$

PB AGC signal level

Fix the mode to CH1, and input 5MHz, 0.2mVP-P to pin ③, and measure AGC output pin ② amplitude.

PB AGC range MAX

Fix the mode to CH1, and input 5MHz, 0.1mVP-P to pin ③, and measure AGC output pin ② amplitude.

PB AGC range MIN

Fix the mode to CH1, and input 5MHz, 0.4mVP-P to pin ③, and measure AGC output pin ② amplitude.

PB AGC secondary distortion

Fix the mode to CH1, and input 5MHz, 0.2mVP-P to pin ③, and measure AGC output pin ② amplitude. Calculate the ratio of 10MHz component to 5MHz component.

$$DR-n(\text{dB}) = 20 \cdot \log \frac{5\text{MHz component (mVP-P)}}{10\text{MHz component (mVP-P)}} \quad n=1, 2, 3, 4$$

PB AGC noise

Fix the mode to CH1, and let pin ② noise through 1MHz BPF, and measure it with rms voltmeter.

ENV. DET detection voltage H

Fix the mode to CH1, and input 5MHz, 0.4mVP-P to pin ③. Measure pin ④ output voltage.

ENV. DET detection voltage M

Fix the mode to CH1, and input 5MHz, 0.2mVP-P to pin ③. Measure pin ④ output voltage.

ENV. DET detection voltage L

Fix the mode to CH1, and input 5MHz, 0.1mVP-P to pin ③. Measure pin ④ output voltage.

ENV. DET detection sensitivity

Fix the mode to CH1, and input 5MHz, 0.2mVP-P ~ 0.3 mVP-P to pin ③. Measure pin ④ output voltage.

Mode selector circuit output waveform

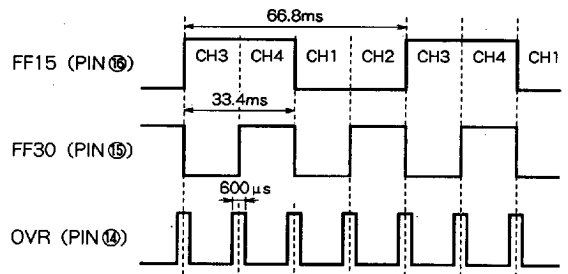

Note. FF30 pulse rise time and fall time are set to 0.5μs or less when voltage is 1V~4V.

- "High" voltage should be always between 4.6V and Vcc (=5V).
- "Low" voltage should be 0.5V or less.
- Delay pulse should be adjusted such that latch pulse will be "L" at the MODE pulse center.

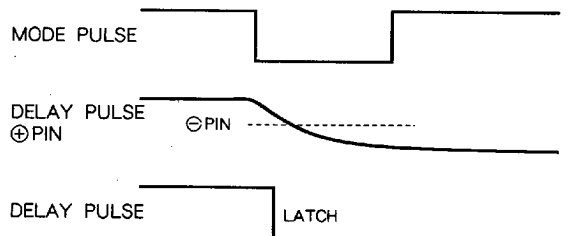

6249826 0023006 719



4-CHANNEL RECORDING AND PLAYBACK AMPLIFIER FOR VCR

TEST CIRCUIT (Cont.)
MODE SELECTOR CIRCUIT

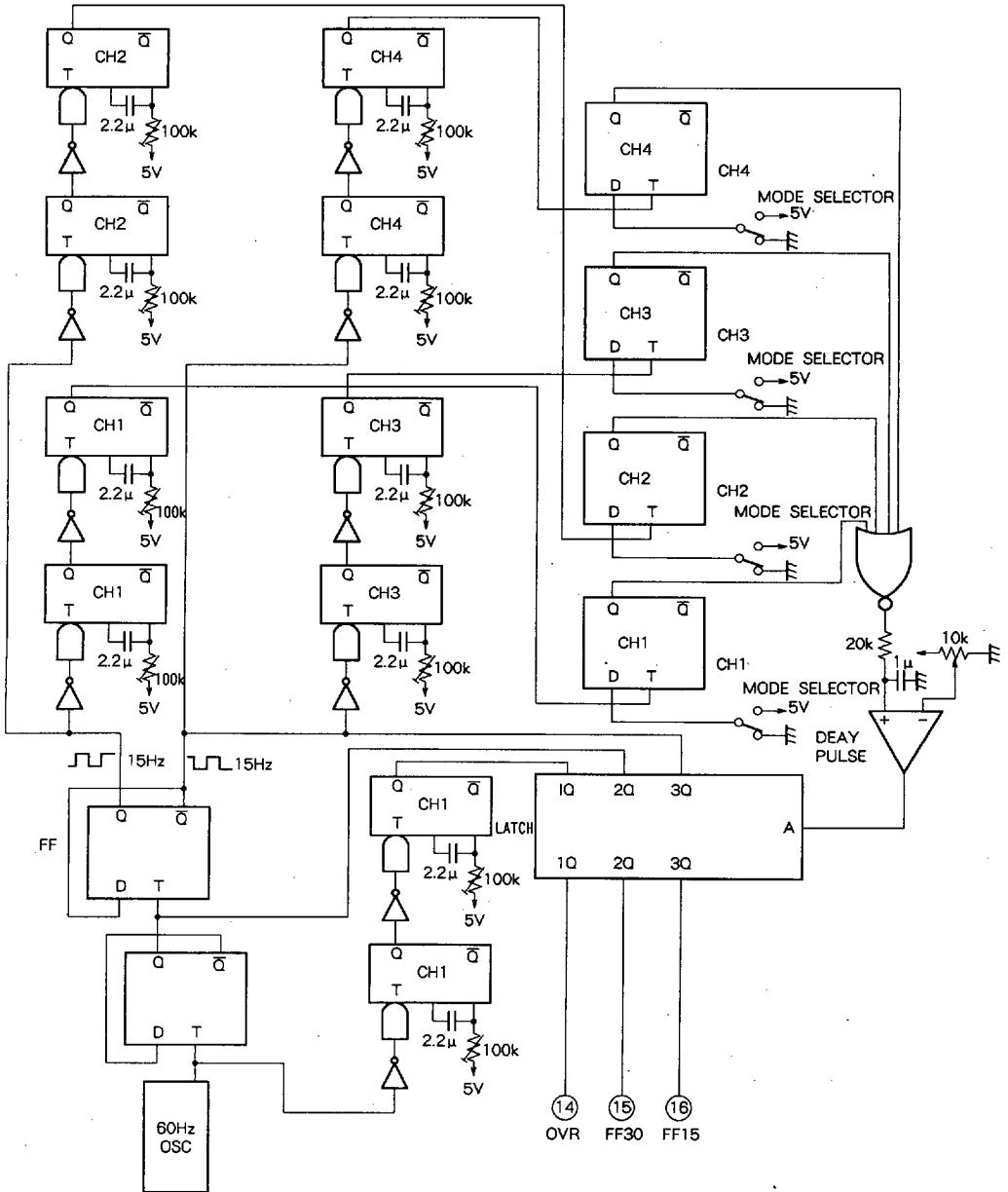

Note. Latched when mode selection switch is set to 5V.

Units Resistance : Ω
Capacitance : F

6249826 0023008 591



M52359FP

4-CHANNEL RECORDING AND PLAYBACK AMPLIFIER FOR VCR

TYPICAL CHARACTERISTICS

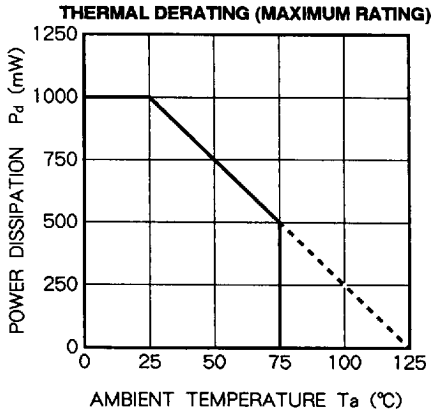

APPLICATION EXAMPLE

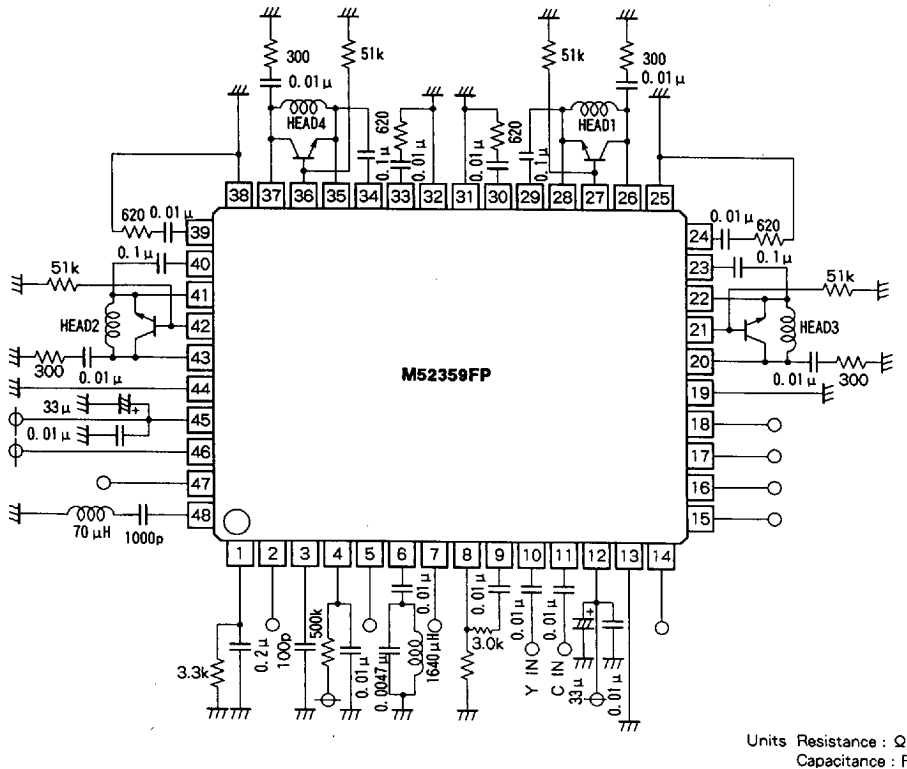

6249826 0023009 428

