

MITSUBISHI (DGLT LOGIC)

**M54548AL****BI-DIRECTIONAL MOTOR DRIVER WITH MOTOR SPEED CONTROL****DESCRIPTION**

The M54548AL, BI-DIRECTIONAL MOTOR DRIVER, consists of a full bridge power driver designed for use in a D-C motor control circuit. The internal operational amplifier is capable for controlling the voltage across the bridge outputs.

**FEATURES**

- Wide operating voltage range
- NMOS and CMOS compatible input
- 1.2A output current
- Integral operational amplifier for output source voltage
- Integral diodes for transient suppression
- Braking mode input
- 12pin shrink single inline package with heat sink

**APPLICATION**

Audio, video cassette recorder

**FUNCTION**

The M54548AL, full bridge motor driver, has the logic circuitry and the quasi-darlington power driver for bidirectional control of D-C motors operating at current up to 1.2A. The inputs,  $S_1$ ,  $S_2$  and  $S_3$ , are capable to control the bridge output polarity and also to select the supply voltage of the pre-driver from the voltages driven by  $V_1$ ,  $V_2$  or the output of the operational amplifier.

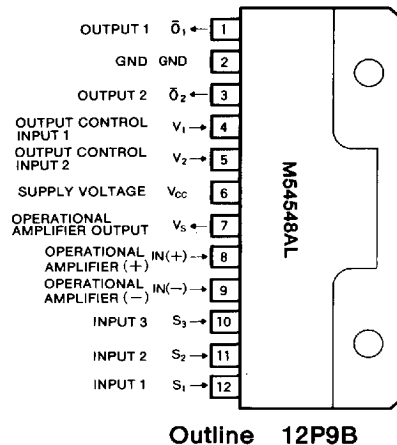
**PIN CONFIGURATION (TOP VIEW)****LOGIC TRUTH TABLE**

Inputs			Output		Driver power supply	Note
$S_1$	$S_2$	$S_3$	$\bar{O}_1$	$\bar{O}_2$	( $V_{cc}$ )	
L	L	L	"OFF" state	"OFF" state	—	STOP
L	L	H	H	L	OP-AMP OUTPUT	PLAY(+)
L	H	L	L	H	OP-AMP OUTPUT	PLAY(-)
L	H	H	H	L	$V_2$	FF(2)
H	L	L	L	H	$V_2$	REW(2)
H	L	H	H	L	$V_1$	FF(1)
H	H	L	L	H	$V_1$	REW(1)
H	H	H	L	L	$V_s$	BRAKING

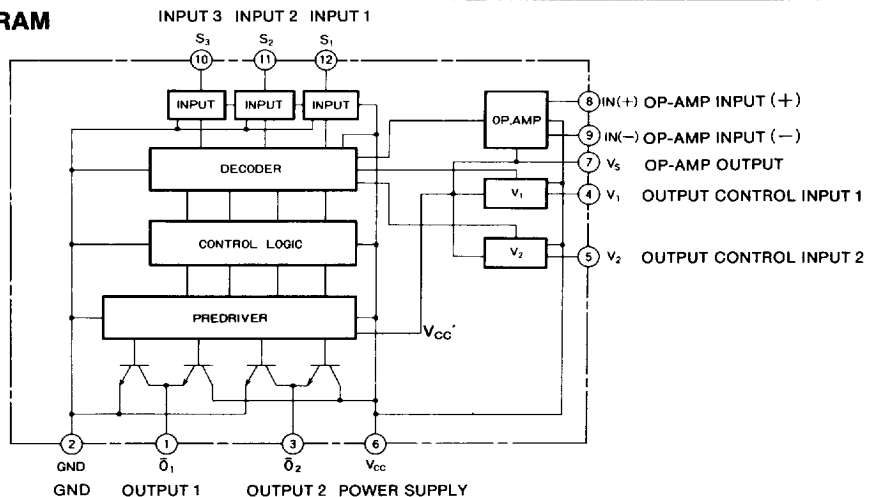
**BLOCK DIAGRAM**

## BI-DIRECTIONAL MOTOR DRIVER WITH MOTOR SPEED CONTROL

ABSOLUTE MAXIMUM RATINGS ( $T_a=25^\circ\text{C}$ , unless otherwise noted)

Symbol	Parameter	Conditions	Ratings	Unit
$V_{CC}$	Supply voltage	With external heat sink (3000mm <sup>2</sup> ×1.5mm <sup>2</sup> )	-0.5~+18	V
$V_i$	Input voltage	4Pin, 5Pin	-0.5~+14 or $V_{CC}$	V
		Other input pins	-0.5~ $V_{CC}$	
$V_o$	Output voltage		-0.5~ $V_{CC}+2.5$	V
$I_{O(max)}$	Allowable motor charge current	$t_{op}=10\text{ms}$ ; Repetitive cycle 0.2 Hz max	±1.2	A
$I_{O(1)}$	Continuous output current (1)		±300	mA
$I_{O(2)}$	Continuous output current (2)	With an external heat sink (3000mm <sup>2</sup> ×1.5mm <sup>2</sup> )	±600	mA
$P_d$	Power dissipation	$T_a=75^\circ\text{C}$	1.1	W
$T_{opr}$	Operating temperature		-10~+75	°C
$T_{stg}$	Storage temperature		-55~+125	°C

RECOMMENDED OPERATING CONDITIONS ( $T_a=-25^\circ\text{C}$ , unless otherwise noted)

Symbol	Parameter	Conditions	Limits			Unit
			Min	Typ	Max	
$V_{CC}$	Supply voltage		4	12	16	V
$I_o$	Output current				±200	mA
$V_{IH}$	High-level input voltage		3			V
$V_{IL}$	Low-level input voltage				1	V
$t_B$	Motor braking interval		10	100		ms

ELECTRICAL CHARACTERISTICS ( $T_a=25^\circ\text{C}$ , unless otherwise noted)

Symbol	Parameter	Test conditions		Limits			Unit
				Min	Typ	Max	
$I_o(\text{leak})$	Output leakage current	$V_{S1}=0\text{V}$ $V_{S2}=0\text{V}$ $V_{S3}=0\text{V}$	$V_o=0\text{V}$ $V_{CC}=V_S=20\text{V}$ $V_o=14\text{V}$ $V_{CC}=V_S=14\text{V}$			-100 +100	μA
$V_{OH(1)}$	High-level output saturation voltage (1)	$V_{CC}=16\text{V}$ $V_{IN(-)}=0\text{V}$ $V_{IN(+)}=3\text{V}$	$V_{S1}=V_{S2}=0\text{V}$ $V_{S3}=3\text{V}$	$I_{OH}=-200\text{mA}$ $I_{OH}=-500\text{mA}$	13 12.8		V
$V_{OH(2)}$	High-level output saturation voltage (2)	$V_{CC}=16\text{V}$ $V_{IN(-)}=0\text{V}$ $V_{IN(+)}=3\text{V}$	$V_{S1}=V_{S3}=0\text{V}$ $V_{S2}=3\text{V}$	$I_{OH}=-200\text{mA}$ $I_{OH}=-500\text{mA}$	13 12.8		V
$V_{OL(1)}$	Low-level output saturation voltage (1)	$V_{CC}=16\text{V}$ $V_{IN(-)}=0\text{V}$ $V_{IN(+)}=3\text{V}$	$V_{S1}=V_{S3}=0\text{V}$ $V_{S2}=3\text{V}$	$I_{OL}=200\text{mA}$ $I_{OL}=500\text{mA}$		0.5 1.4	V
$V_{OL(2)}$	Low-level output saturation voltage (2)	$V_{CC}=16\text{V}$ $V_{IN(-)}=0\text{V}$ $V_{IN(+)}=3\text{V}$	$V_{S1}=V_{S2}=0\text{V}$ $V_{S3}=3\text{V}$	$I_{OL}=200\text{mA}$ $I_{OL}=500\text{mA}$		0.5 1.4	V
$I_{IH}$	High-level input current	$V_{CC}=16\text{V}$ , $V_S=3\text{V}$ ( $S_1, S_2, S_3$ )				10	μA
$I_{IL}$	Low-level input current	$V_{CC}=16\text{V}$ , $V_S=0\text{V}$ ( $S_1, S_2, S_3$ )				-20	μA
$I_{CC}$	Supply current	$V_{CC}=16\text{V}$ , $V_{S1}=V_{S2}=V_{S3}=3\text{V}$				30	mA
A	Op-amp open loop gain				50		dB

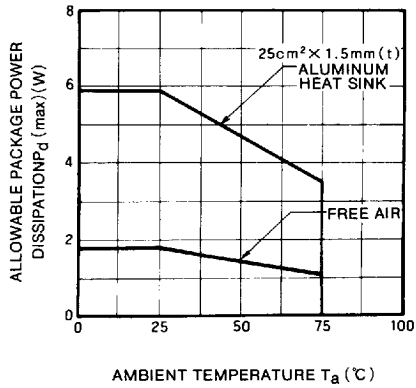
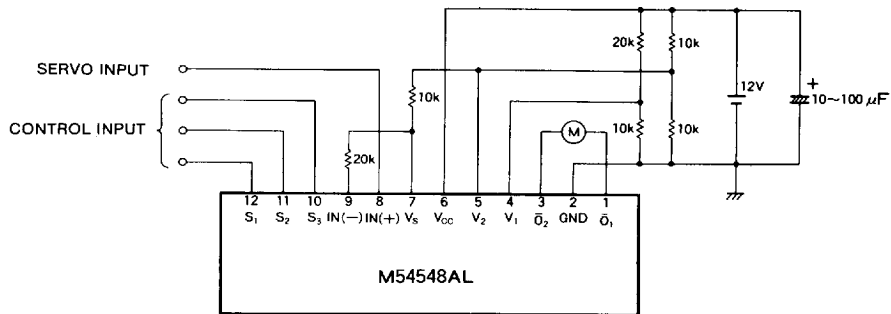
**BI-DIRECTIONAL MOTOR DRIVER WITH MOTOR SPEED CONTROL****TYPICAL CHARACTERISTICS****ALLOWABLE AVERAGE  
POWER DISSIPATION****APPLICATION EXAMPLE**Unit :  $\Omega$