

M54549AL

DUAL BI-DIRECTIONAL MOTOR DRIVER WITH BRAKE FUNCTION AND THERMAL SHUT DOWN FUNCTION

DESCRIPTION

The M54549AL is a semiconductor IC capable of directly driving 2 smallsize bi-directional motors for forward/reverse rotation.

FEATURES

- Two built-in motor driver circuits
- Wide operating voltage range ($V_{CC} = 4V$ to $16V$)
- Direct drive capability by TTL, PMOS and CMOS IC outputs
- Low output saturation voltage (large voltage across motor)
- Large output current drive (I_o (max) = $\pm 1.2A$)
- With brake function
- Built-in thermal protector circuit

APPLICATION

Commercial-use equipment, audio such as tape recorder or radio cassette recorder, and VCR.

FUNCTIONAL DESCRIPTION

The M54549AL consists of a decoder and two motor drivers or forward/reverse rotation (built-in 2 circuits).

3 inputs of SE, S1 and S2 allow selection of an output state out of the logic truth table.

The sinking outputs of motor drivers indicate low saturation voltage (V_{OL} (TYP) = $0.3V$, at $I_o = 200mA$) in a low sinking current area ($I_{OL} \leq 300mA$), and become a Darlington output in a large current area ($I_{OL} > 300mA$) to drive motor rush current $I_{OP(max)} = 1.2A$.

The IC is also provided with a built-in thermal protector circuit to protect it from thermal destruction in case of abnormal condition such as motor blocking.

PIN CONFIGURATION (TOP VIEW)

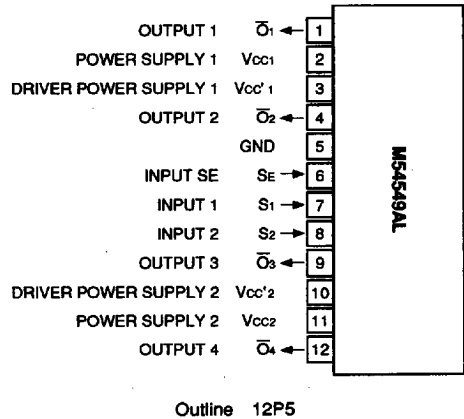

LOGIC TRUTH TABLE

INPUT			OUTPUT				NOTE	
SE	S1	S2	\bar{O}_1	\bar{O}_2	\bar{O}_3	\bar{O}_4	Output \bar{O}_1, \bar{O}_2	Output \bar{O}_3, \bar{O}_4
0	0	0	OFF	OFF	OFF	OFF	Open	Open
0	1	0	1	0	OFF	OFF	↻	Open
0	0	1	0	1	OFF	OFF	↻	Open
0	1	1	0	0	OFF	OFF	Braking	Open
1	0	0	OFF	OFF	OFF	OFF	Open	Open
1	1	0	OFF	OFF	1	0	Open	↻
1	0	1	OFF	OFF	0	1	Open	↻
1	1	1	OFF	OFF	0	0	Open	Braking

BLOCK DIAGRAM

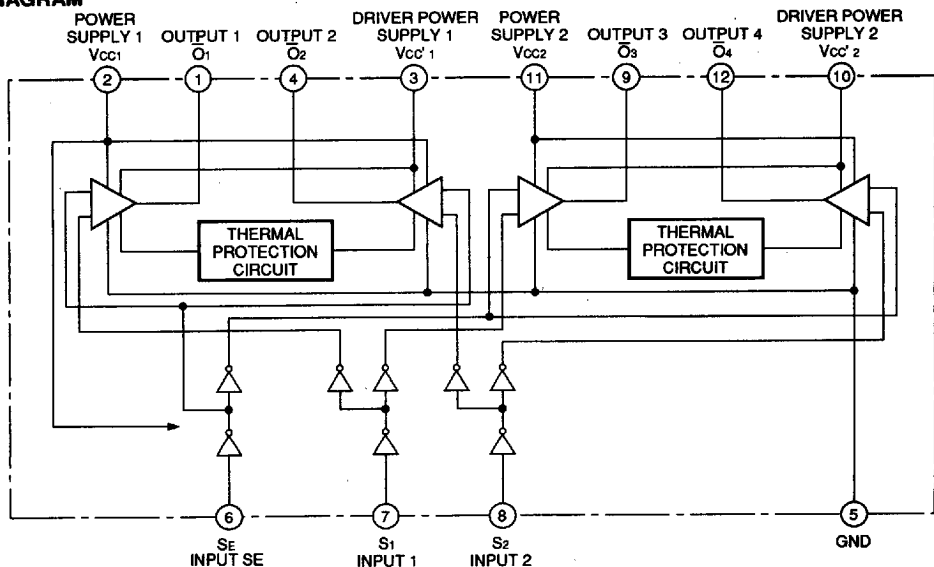

6249826 0021583 TT2



**DUAL BI-DIRECTIONAL MOTOR DRIVER
WITH BRAKE FUNCTION AND THERMAL SHUT DOWN FUNCTION**

ABSOLUTE MAXIMUM RATINGS (Ta=25°C, unless otherwise noted)

Symbol	Parameter	Conditions	Ratings	Unit
Vcc	Supply voltage		-0.5 to +18	V
Vcc'	Driver supply voltage		-0.5 to +18	V
Vi	Input voltage		0 to Vcc	V
Vo	Output voltage		-2 to Vcc'+2.5	V
Io (max)	Peak output current	top=10ms : Repetitive cycle 0.2Hz max	±1.2	A
Io (1)	Continuous output current (1)		±330	mA
Pd	Power dissipation	Ta=75°C	830	mW
Topr	Operating temperature		-20 to +75	°C
Tstg	Storage temperature		-55 to +125	°C

RECOMMENDED OPERATING CONDITIONS (Ta=25°C, unless otherwise noted)

Symbol	Parameter	Test conditions	Limits			Unit
			Min.	Typ.	Max.	
Vcc	Supply voltage		4	12	16	V
Io	Continuous output current				±300	mA
ViH	"H" Input voltage		2		Vcc	V
ViL	"L" Input voltage		0		0.4	V
tB	Motor braking interval		100			ms
TJ(shut)	Thermal shutdown temperature			150		°C

ELECTRICAL CHARACTERISTICS (Ta=25°C, unless otherwise noted)

Symbol	Parameter	Test conditions	Limits			Unit	
			Min.	Typ.	Max.		
Io (leak)	Output leak current	Vcc=Vcc'=18V Vs1=Vs2=0.4V VSE=0.4V or 2V	Vo=18V			100	μA
			Vo=0V			-100	
VoH	"H" Output saturation voltage	Vcc=Vcc'=12V	IoH=-200mA	10.8	11.2		V
			IoH=-500mA	10.7	11.1		
VoL	"L" Output saturation voltage	Vcc=Vcc'=12V	IoL=200mA		0.2	0.5	V
			IoL=500mA		0.95	1.35	
IiH	"H" Input current	Vcc=Vcc'=12V, Vi=2V	50		120	μA	
Icc1	Supply current (1)	Vcc=Vcc'=12V Output open	VSE=Vs1=Vs2=0.4V			10	mA
			VSE=Vs1=0.4V, Vs2=2V			20	
Icc2	Supply current (2)	Vcc=Vcc'=12V Output open	VSE=2V, Vs1=Vs2=0.4V			10	mA
			VSE=Vs1=2V, Vs2=0.4V			20	

6249826 0021584 939



M54549AL

DUAL BI-DIRECTIONAL MOTOR DRIVER WITH BRAKE FUNCTION AND THERMAL SHUT DOWN FUNCTION

TYPICAL CHARACTERISTICS

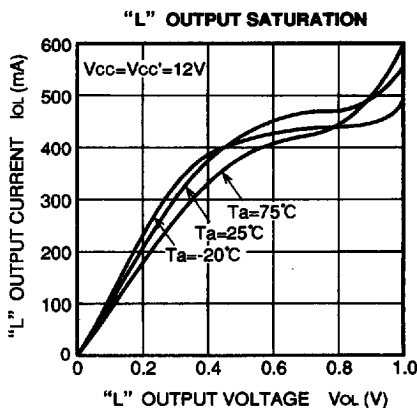
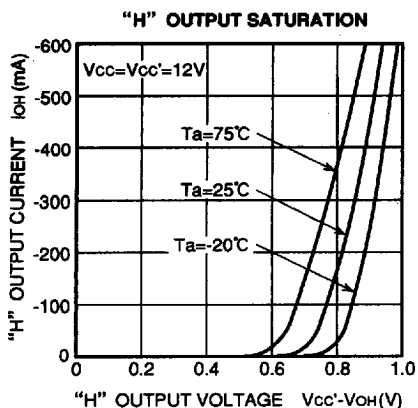
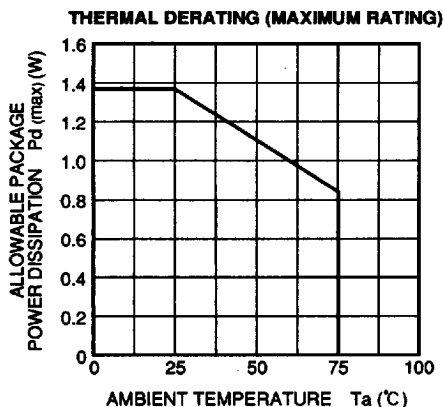

6249826 0021585 875

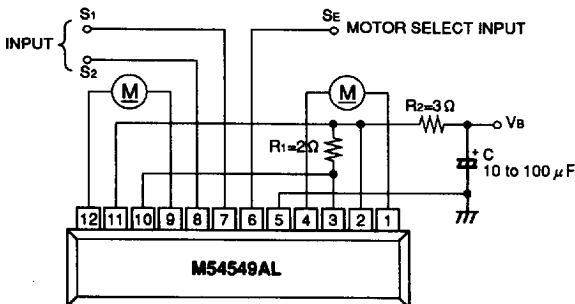

**DUAL BI-DIRECTIONAL MOTOR DRIVER
WITH BRAKE FUNCTION AND THERMAL SHUT DOWN FUNCTION****APPLICATION EXAMPLES****PRECAUTIONS FOR APPLICATION**

(1) The thermal protection of the IC may not work depending on an abnormal condition (such as oscillation, low supply voltage or output short). When using the function, check its operation in the actual using state.

If the motor has a large counter electromotive force at a braking time, etc., the internal parasitic Di may malfunction.

If fly-back current of 1A or more flows, put a shottkey Di between the output and the GND.

Remember that the IC has an about $10\mu\text{s}$ delay in output switching for high-speed applications such as PWM.

(2) As far as motor control and driver IC's are concerned, some possibilities are considered for these IC's to cause such unexpected cases as fire or smoke if they are used beyond its ratings in datasheet or used, even transiently, under the overload conditions. So your action will be highly appreciated to fully look into the rating limits and the using conditions before you use these IC's.

And if these IC's are to be used under the conditions out of our specifications, please never fail to give us a contact as to under what conditions they are used.

■ 6249826 0021586 701 ■

