

**BI-DIRECTIONAL MOTOR DRIVER WITH MOTOR SPEED CONTROL**

**DESCRIPTION**

The M54648AL is a semiconductor integrated circuit, capable of directly driving bi-directional micro motor, with a built in speed control circuit.

**FEATURES**

- Wide operating voltage range ( $V_{CC}=4\sim 18V$ )
- N MOS, C MOS IC output for direct drive
- Large output sink current ( $I_{O(max)}=\pm 3.0A$ )
- Built-in operational amplifier for "H" output voltage control
- Built-in clamp diode
- Braking mode input
- Compact power package requiring small space

**APPLICATION**

Audio tape deck player, radio cassette player, VTR, Home-use equipment

**FUNCTION**

The M54648AL, full bridge motor driver, has the logic circuitry and the quasi-darlington power driver for driver for bidirectional control of D-C motors operating at current up to 3.0A.

The inputs,  $S_1$ ,  $S_2$  and  $S_3$ , are capable to control the bridge output polarity and also to select the supply Voltage of the predriver from the voltages driven by  $V_1$ ,  $V_2$  or the output of the operational amplifier.

The internal thermal shutdown protector protects the IC from thermal destruction due to blocking of motor, etc.

**PIN CONFIGURATION (TOP VIEW)**

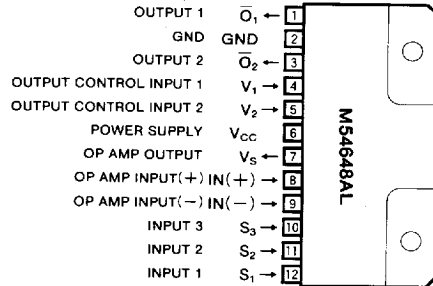

Outline 12P9B

**LOGIC TRUTH TABLE**

Input			Output		Driver power supply ( $V_{CC}$ )	Note
$S_1$	$S_2$	$S_3$	$\bar{O}_1$ state	$\bar{O}_2$ state		
L	L	L	"OFF" state	"OFF" state	—	STOP
L	L	H	H	L	OP AMP OUTPUT	PLAY(+)
L	H	L	L	H	OP AMP OUTPUT	PLAY(-)
L	H	H	H	L	$V_2$	FF(2)
H	L	L	L	H	$V_2$	REW(2)
H	L	H	H	L	$V_1$	REW(1)
H	H	L	L	H	$V_1$	REW(1)
H	H	H	L	L	$V_s$	BRAKE

**BLOCK DIAGRAM**

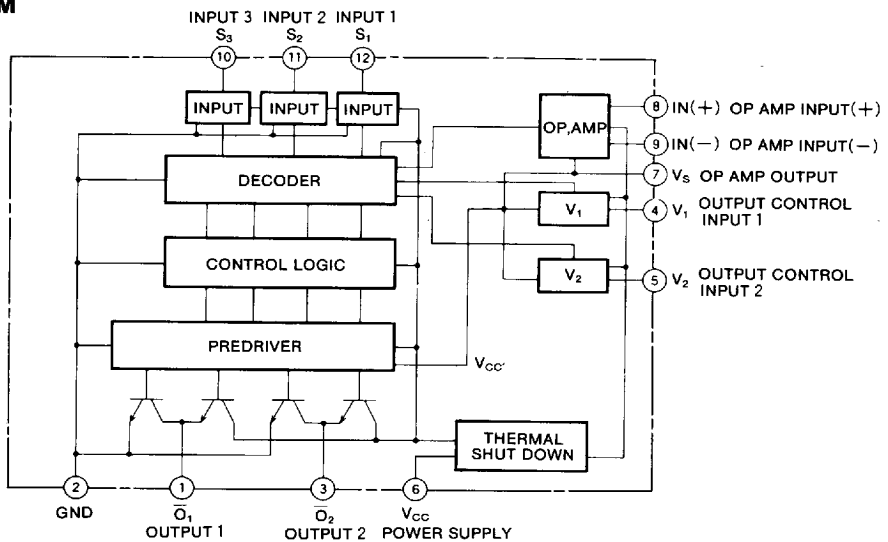

**BI-DIRECTIONAL MOTOR DRIVER WITH MOTOR SPEED CONTROL**

**ABSOLUTE MAXIMUM RATINGS** ( $T_a=25^\circ\text{C}$ , unless otherwise noted)

Symbol	Parameter	Conditions	Ratings	Unit
$V_{CC}$	Supply voltage	With an external heat sink (3000mm <sup>2</sup> X1.5mmt)	-0.5~+20	V
$V_1$	Input voltage	4Pin, 5Pin	-0.5~+14 or $V_{CC}$	V
		Inputs pin other than the above	-0.5~ $V_{CC}$	
$V_O$	Output voltage		-2.0~ $V_{CC}+2.5$	V
$I_{O(max)}$	Peak output current	$t_{op}=10\text{ms}$ ; repetitive cycle 0.2Hz max	$\pm 3.0$	A
$I_{O(1)}$	Continuous output current (1)		$\pm 300$	mA
$I_{O(2)}$	Continuous output current (2)	With an external heat sink (3000mm <sup>2</sup> X1.5mmt)	$\pm 800$	mA
$P_d$	Power dissipation	$T_a=75^\circ\text{C}$	0.8	W
$T_{opr}$	Operating temperature		-10~+75	$^\circ\text{C}$
$T_{stg}$	Storage temperature		-55~+125	$^\circ\text{C}$

**RECOMMENDED OPERATING CONDITIONS** ( $T_a=25^\circ\text{C}$ , unless otherwise noted)

Symbol	Parameter	Conditions	Limits			Unit
			Min	Typ	Max	
$V_{CC}$	Supply voltage		4	12	18	V
$I_O$	Output current				$\pm 300$	mA
$V_{IH}$	High-level input voltage		3		$V_{CC}$	V
$V_{IL}$	Low-level input voltage		0		1	V
$t_B$	Motor braking interval		100			ms
$t_j(\text{shut})$	Thermal shutdown temperature		125	150		$^\circ\text{C}$

**ELECTRICAL CHARACTERISTICS** ( $T_a=25^\circ\text{C}$ , unless otherwise noted)

Symbol	Parameter	Test conditions		Limits			Unit
				Min	Typ	Max	
$I_{O(leak)}$	Output leakage current	$V_{S1}=0V$ $S_{S2}=0V$ $V_{S3}=0V$	$V_O=0V$ $V_{CC}=V_S=20V$ $V_O=14V$ $V_{CC}=V_S=14V$			-100  +100	$\mu\text{A}$
$V_{OH(1)}$	High-level output voltage (1)	$V_{CC}=16V$ $V_{IN(-)}=0V$ $V_{IN(+)}=3V$	$V_{S1}=V_{S2}=0V$ $V_{S3}=3V$	$I_{OH}=-200\text{mA}$ $I_{OH}=-500\text{mA}$	13 12.8		V
$V_{OH(2)}$	High-level output voltage (2)	$V_{CC}=16V$ $V_{IN(-)}=0V$ $V_{IN(+)}=3V$	$V_{S1}=V_{S3}=0V$ $V_{S2}=3V$	$I_{OH}=-200\text{mA}$ $I_{OH}=-500\text{mA}$	13 12.8		V
$V_{OL(1)}$	Low-level output voltage (1)	$V_{CC}=16V$ $V_{IN(-)}=0V$ $V_{IN(+)}=3V$	$V_{S1}=V_{S3}=0V$ $V_{S2}=3V$	$I_{OL}=200\text{mA}$ $I_{OL}=500\text{mA}$		1.1 1.2	V
$V_{OL(2)}$	Low-level output voltage (2)	$V_{CC}=16V$ $V_{IN(-)}=0V$ $V_{IN(+)}=3V$	$V_{S1}=V_{S2}=0V$ $V_{S3}=3V$	$I_{OL}=200\text{mA}$ $I_{OL}=500\text{mA}$		1.1 1.2	V
$I_{IH}$	High-level input current	$V_{CC}=16V, V_S=3V(S_1, S_2, S_3)$				10	$\mu\text{A}$
$I_{IL}$	Low-level input current	$V_{CC}=16V, V_S=0V(S_1, S_2, S_3)$				-20	$\mu\text{A}$
$I_{CC}$	Supply current	$V_{CC}=16V, V_{S1}=V_{S2}=V_{S3}=3V$				30	mA
A	Op amp open-loop-gain				50		dB

**BI-DIRECTIONAL MOTOR DRIVER WITH MOTOR SPEED CONTROL**

**TYPICAL CHARACTERISTICS**

**ALLOWABLE AVERAGE POWER DISSIPATION**

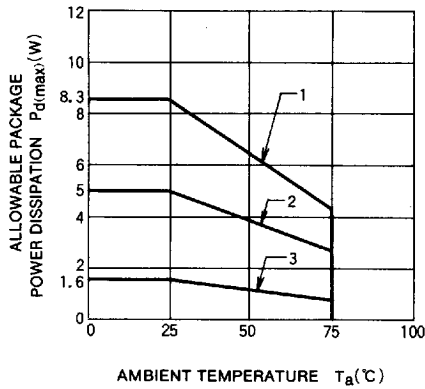

- 1) WITH HEAT SINK OF INFINITE SIZE
- 2) 25cm<sup>2</sup>×1.5mm ALUMINUM HEAT SINK
- 3) FREE AIR

**APPLICATION EXAMPLE**

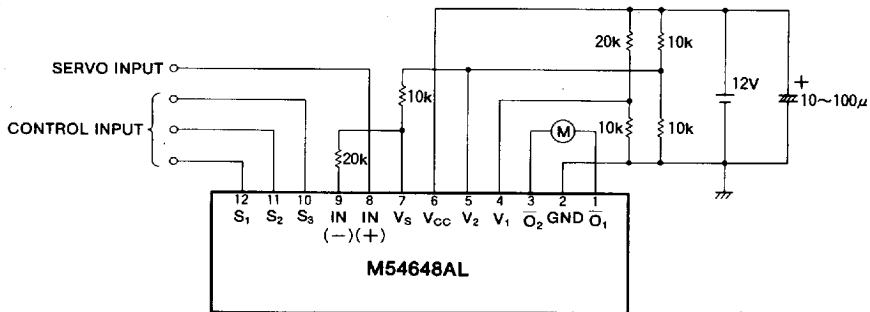

Unit : Ω