

DUAL J-K FLIP FLOP WITH PRESET AND CLEAR

- HIGH SPEED
f_{MAX} = 67 MHz (TYP.) AT V_{CC} = 5 V
- LOW POWER DISSIPATION
I_{CC} = 2 μA AT T_A = 25 °C
- HIGH NOISE IMMUNITY
V_{NIH} = V_{NIL} = 28 % V_{CC} (MIN.)
- OUTPUT DRIVE CAPABILITY
10 LSTTL LOADS
- SYMMETRICAL OUTPUT IMPEDANCE
|I_{OH}| = I_{OL} = 4 mA (MIN.)
- BALANCED PROPAGATION DELAYS
t_{PLH} = t_{PHL}
- WIDE OPERATING VOLTAGE RANGE
V_{CC} (OPR) = 2 V TO 6 V
- PIN AND FUNCTION COMPATIBLE
WITH 54/74LS112

DESCRIPTION

The M54/74HC112 is a high speed CMOS DUAL J-K FLIP-FLOP WITH PRESET AND CLEAR fabricated in silicon gate C²MOS technology. It has the same high speed performance of LSTTL combined with true CMOS low power consumption. The M54HC112/M74HC112 dual JK flip-flop features individual J, K, clock, and asynchronous set and clear inputs for each flip-flop. When the clock goes high, the inputs are enabled and data will be accepted. The logic level of the J and K inputs may be allowed to change when the clock pulse is high and the bistable will function as shown in the truth table. Input data is transferred to the input on the negative going edge of the clock pulse. All inputs are equipped with protection circuits against static discharge and transient excess voltage.

INPUT AND OUTPUT EQUIVALENT CIRCUIT

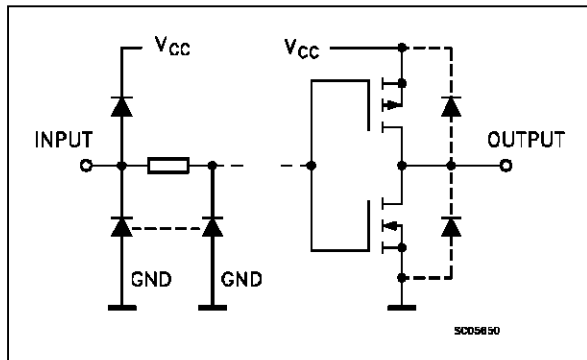

B1R
(Plastic Package)

F1R
(Ceramic Package)

M1R
(Micro Package)

C1R
(Chip Carrier)

ORDER CODES :
M54HC112F1R M74HC112M1R
M74HC112B1R M74HC112C1R

PIN CONNECTIONS (top view)

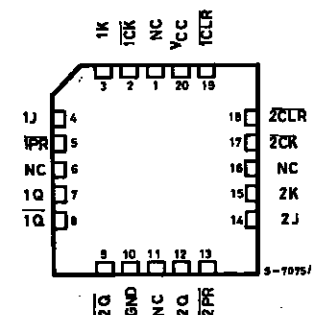
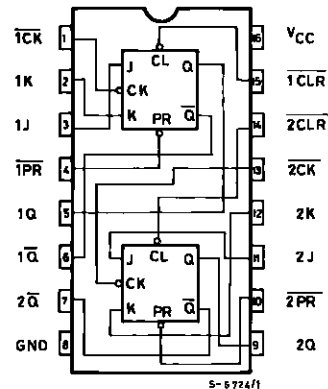

M54/M74HC112

TRUTH TABLE

INPUTS					OUTPUTS		FUNCTION
CLR	PR	J	K	CK	Q	\bar{Q}	
L	H	X	X	X	L	H	CLEAR
H	L	X	X	X	H	L	PRESET
L	L	X	X	X	H	H	
H	H	L	L	$\bar{\square}$	Q_n	\bar{Q}_n	NO CHANGE
H	H	H	L	$\bar{\square}$	H	L	
H	H	L	H	$\bar{\square}$	L	H	
H	H	H	H	$\bar{\square}$	\bar{Q}_n	Q_n	TOGGLE
H	H	X	X	\square	Q_n	\bar{Q}_n	NO CHANGE

X: Don't Care

PIN DESCRIPTION

PIN No	SYMBOL	NAME AND FUNCTION
1, 13	$\overline{1CK}, \overline{2CK}$	Clock Input (HIGH to LOW edge triggered)
2, 12	1K, 2K	Data Inputs: Flip-Flop 1 and 2
3, 11	1J, 2J	Data Inputs: Flip-Flop 1 and 2
4, 10	$\overline{1PR}, \overline{2PR}$	Set Inputs
5, 9	1Q, 2Q	True Flip-Flop Outputs
6, 7	$\overline{1Q}, \overline{2Q}$	Complement Flip-Flop Outputs
15, 14	$\overline{1CLR}, \overline{2CLR}$	Reset inputs
8	GND	Ground (0V)
16	V _{CC}	Positive Supply Voltage

IEC LOGIC SYMBOL

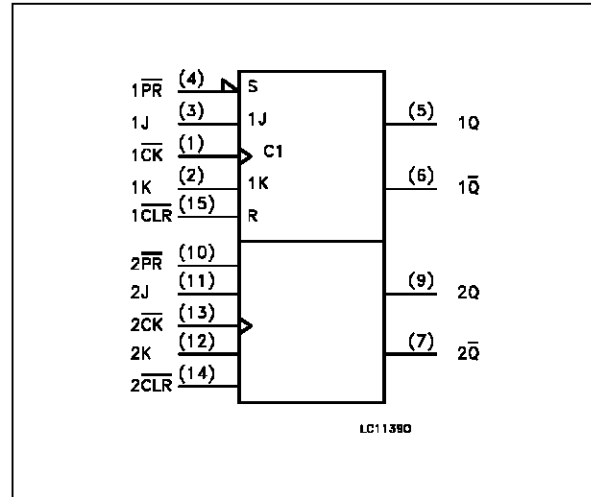

LOGIC DIAGRAM (1/2 Package)

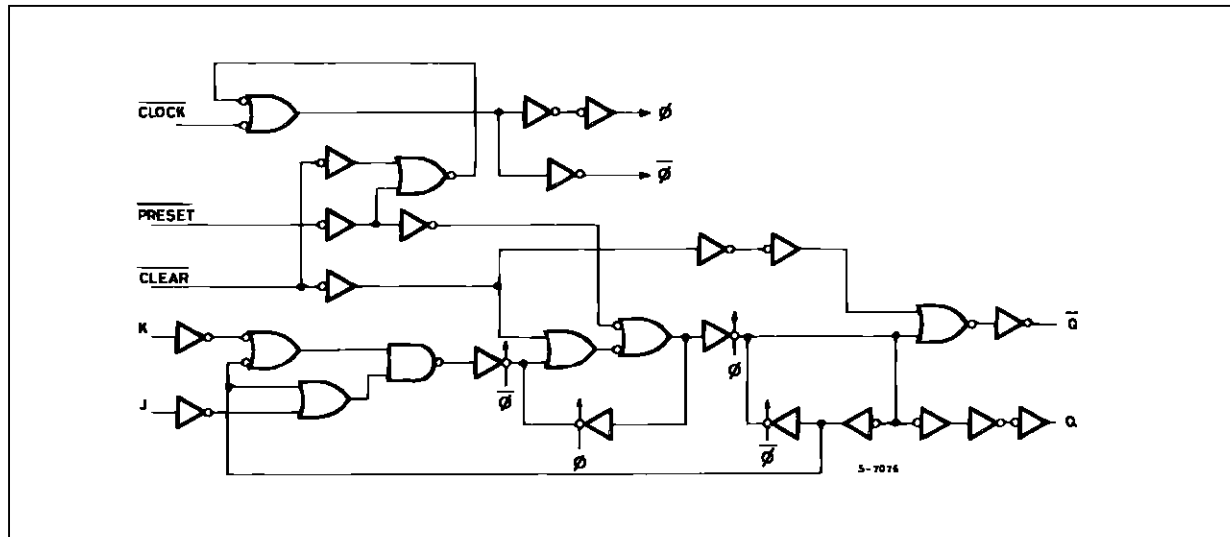

ABSOLUTE MAXIMUM RATINGS

Symbol	Parameter	Value	Unit
V _{CC}	Supply Voltage	-0.5 to +7	V
V _I	DC Input Voltage	-0.5 to V _{CC} + 0.5	V
V _O	DC Output Voltage	-0.5 to V _{CC} + 0.5	V
I _{IK}	DC Input Diode Current	± 20	mA
I _{OK}	DC Output Diode Current	± 20	mA
I _O	DC Output Source Sink Current Per Output Pin	± 25	mA
I _{CC} or I _{GND}	DC V _{CC} or Ground Current	± 50	mA
P _D	Power Dissipation	500 (*)	mW
T _{stg}	Storage Temperature	-65 to +150	°C
T _L	Lead Temperature (10 sec)	300	°C

Absolute Maximum Ratings are those values beyond which damage to the device may occur. Functional operation under these condition is not implied.

(*) 500 mW: ≡ 65 °C derate to 300 mW by 10mW/°C: 65 °C to 85 °C

RECOMMENDED OPERATING CONDITIONS

Symbol	Parameter	Value	Unit	
V _{CC}	Supply Voltage	2 to 6	V	
V _I	Input Voltage	0 to V _{CC}	V	
V _O	Output Voltage	0 to V _{CC}	V	
T _{op}	Operating Temperature: M54HC Series M74HC Series	-55 to +125 -40 to +85	°C °C	
t _r , t _f	Input Rise and Fall Time	V _{CC} = 2 V V _{CC} = 4.5 V V _{CC} = 6 V	0 to 1000 0 to 500 0 to 400	ns

DC SPECIFICATIONS

Symbol	Parameter	Test Conditions		Value						Unit		
		V _{CC} (V)		T _A = 25 °C 54HC and 74HC			-40 to 85 °C 74HC		-55 to 125 °C 54HC			
				Min.	Typ.	Max.	Min.	Max.	Min.		Max.	
V _{IH}	High Level Input Voltage	2.0		1.5			1.5		1.5		V	
		4.5		3.15			3.15		3.15			
		6.0		4.2			4.2		4.2			
V _{IL}	Low Level Input Voltage	2.0				0.5		0.5		0.5	V	
		4.5				1.35		1.35		1.35		
		6.0				1.8		1.8		1.8		
V _{OH}	High Level Output Voltage	2.0	V _I = V _{IH} or V _{IL}	I _O = -20 μA	1.9	2.0		1.9		1.9	V	
		4.5			4.4	4.5		4.4		4.4		
		6.0			5.9	6.0		5.9		5.9		
		4.5	I _O = -4.0 mA	4.18	4.31		4.13		4.10			
		6.0		I _O = -5.2 mA	5.68	5.8		5.63		5.60		
V _{OL}	Low Level Output Voltage	2.0	V _I = V _{IH} or V _{IL}	I _O = 20 μA		0.0	0.1		0.1		V	
		4.5				0.0	0.1		0.1			0.1
		6.0				0.0	0.1		0.1			0.1
		4.5		I _O = 4.0 mA	0.17	0.26		0.33		0.40		
		6.0			I _O = 5.2 mA	0.18	0.26		0.33			0.40
I _I	Input Leakage Current	6.0	V _I = V _{CC} or GND			±0.1		±1		±1	μA	
I _{CC}	Quiescent Supply Current	6.0	V _I = V _{CC} or GND			2		20		40	μA	

AC ELECTRICAL CHARACTERISTICS ($C_L = 50$ pF, Input $t_r = t_f = 6$ ns)

Symbol	Parameter	Test Conditions		Value						Unit	
		V_{CC} (V)		$T_A = 25\text{ }^\circ\text{C}$ 54HC and 74HC			-40 to $85\text{ }^\circ\text{C}$ 74HC		-55 to $125\text{ }^\circ\text{C}$ 54HC		
				Min.	Typ.	Max.	Min.	Max.	Min.		Max.
t_{TLH} t_{THL}	Output Transition Time	2.0			30	75		95		110	ns
		4.5			8	15		19		22	
		6.0			7	13		16		19	
t_{PLH} t_{PHL}	Propagation Delay Time ($\overline{CK} - Q, \overline{Q}$)	2.0			52	125		155		190	ns
		4.5			16	25		31		38	
		6.0			14	21		26		32	
t_{PLH} t_{PHL}	Propagation Delay Time (CLR, PR - Q, \overline{Q})	2.0			68	135		170		205	ns
		4.5			17	27		34		41	
		6.0			14	23		29		35	
f_{MAX}	Maximum Clock Frequency	2.0			8	16		6.4		5.4	MHz
		4.5			40	68		32		27	
		6.0			47	79		38		32	
$t_{W(H)}$ $t_{W(L)}$	Minimum Pulse Width (CLOCK)	2.0			20	75		95		110	ns
		4.5			5	15		19		22	
		6.0			4	13		16		19	
$t_{W(L)}$	Minimum Pulse Width (CLR, PR)	2.0			20	75		95		110	ns
		4.5			5	15		19		22	
		6.0			4	13		16		19	
t_s	Minimum Set-up Time	2.0			28	75		95		110	ns
		4.5			7	15		19		22	
		6.0			6	13		16		19	
t_h	Minimum Hold Time	2.0				0		0		0	ns
		4.5				0		0		0	
		6.0					0		0	0	
t_{REM}	Minimum Removal Time (CLR, PR)	2.0			24	50		60		70	ns
		4.5			4	10		12		14	
		6.0			3	9		10		12	
C_{IN}	Input Capacitance				5	10		10		10	pF
C_{PD} (*)	Power Dissipation Capacitance				33						pF

(*) C_{PD} is defined as the value of the IC's internal equivalent capacitance which is calculated from the operating current consumption without load. (Refer to Test Circuit). Average operating current can be obtained by the following equation. $I_{CC(opr)} = C_{PD} \cdot V_{CC} \cdot f_{IN} + I_{CC}/2$ (per FLIP/FLOP)

SWITCHING CHARACTERISTICS TEST WAVEFORM

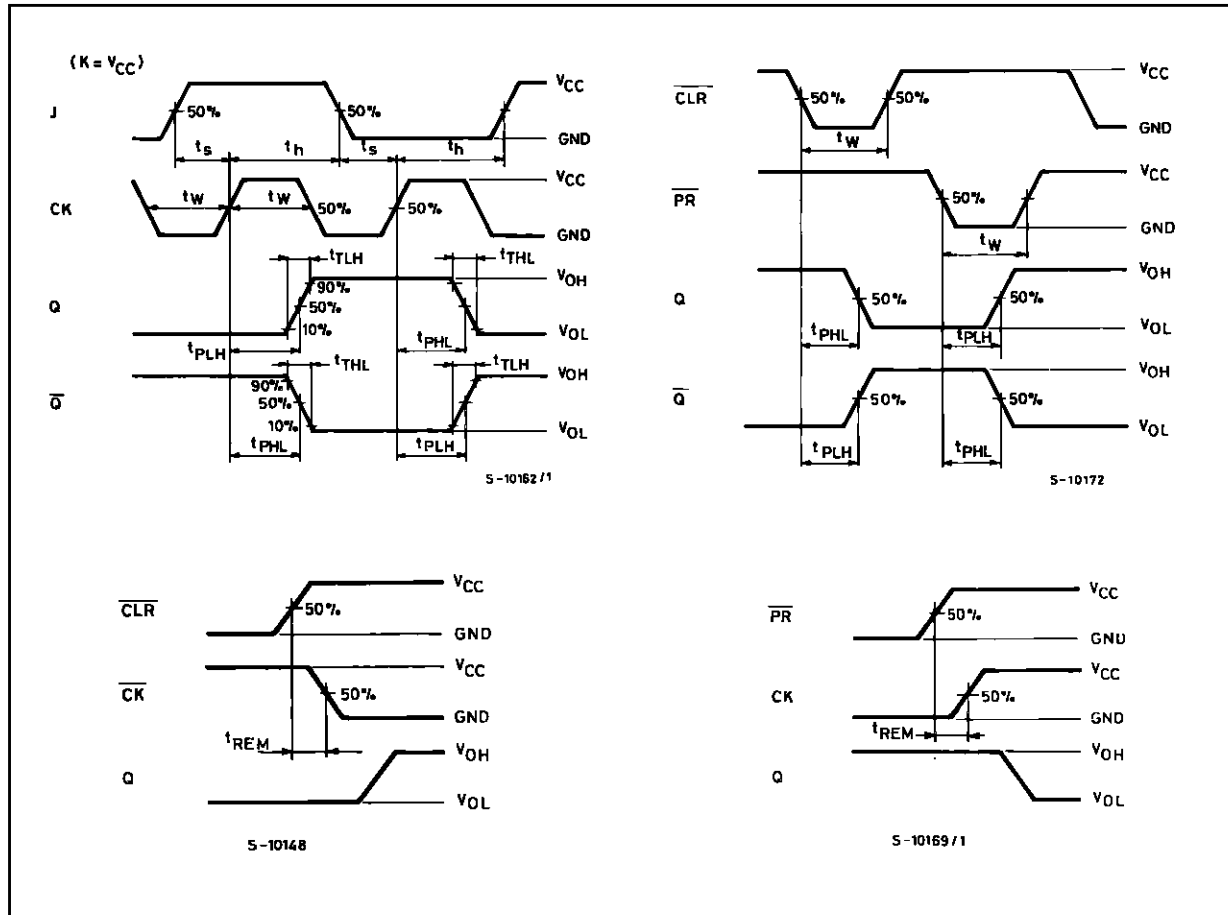

TEST CIRCUIT (Opr.)

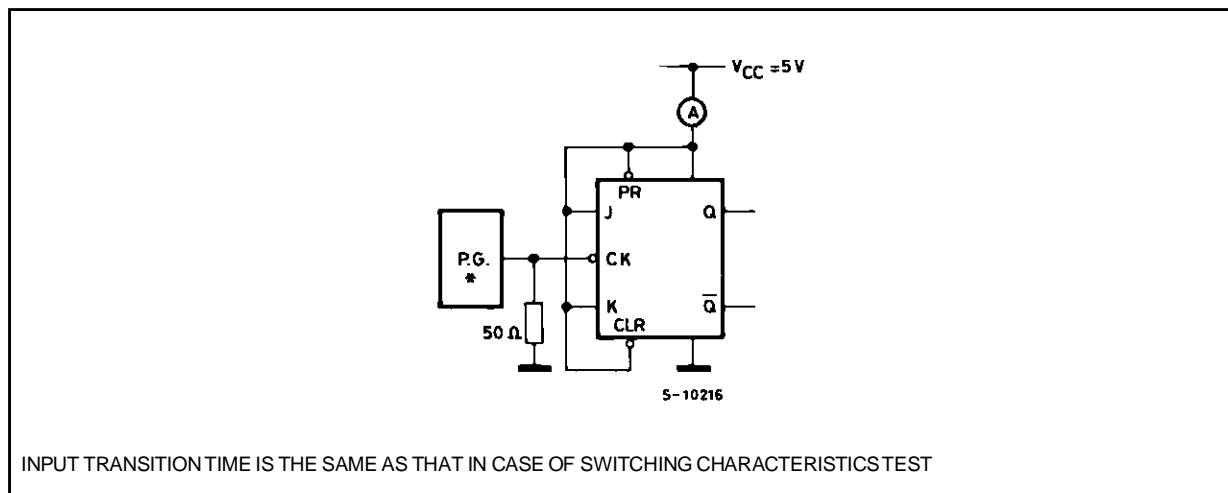

INPUT TRANSITION TIME IS THE SAME AS THAT IN CASE OF SWITCHING CHARACTERISTICS TEST

Plastic DIP16 (0.25) MECHANICAL DATA

DIM.	mm			inch		
	MIN.	TYP.	MAX.	MIN.	TYP.	MAX.
a1	0.51			0.020		
B	0.77		1.65	0.030		0.065
b		0.5			0.020	
b1		0.25			0.010	
D			20			0.787
E		8.5			0.335	
e		2.54			0.100	
e3		17.78			0.700	
F			7.1			0.280
I			5.1			0.201
L		3.3			0.130	
Z			1.27			0.050

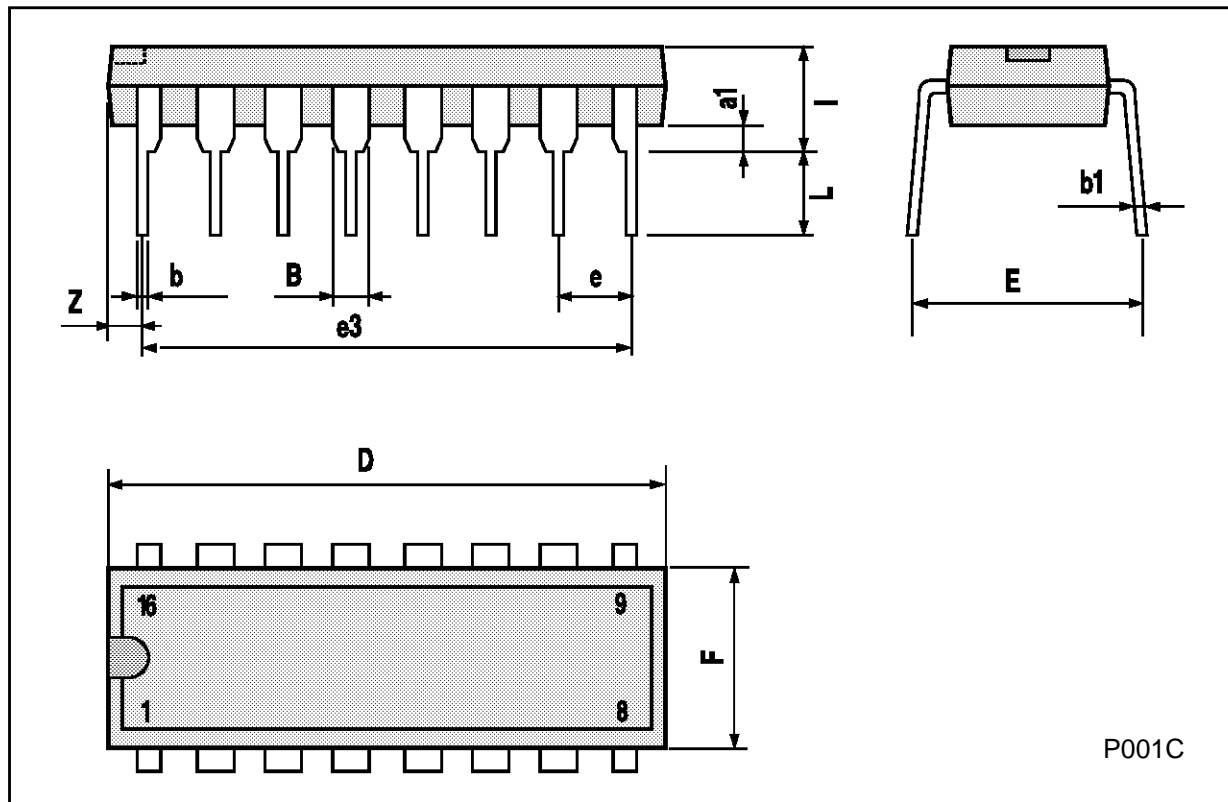

Ceramic DIP16/1 MECHANICAL DATA

DIM.	mm			inch		
	MIN.	TYP.	MAX.	MIN.	TYP.	MAX.
A			20			0.787
B			7			0.276
D		3.3			0.130	
E	0.38			0.015		
e3		17.78			0.700	
F	2.29		2.79	0.090		0.110
G	0.4		0.55	0.016		0.022
H	1.17		1.52	0.046		0.060
L	0.22		0.31	0.009		0.012
M	0.51		1.27	0.020		0.050
N			10.3			0.406
P	7.8		8.05	0.307		0.317
Q			5.08			0.200

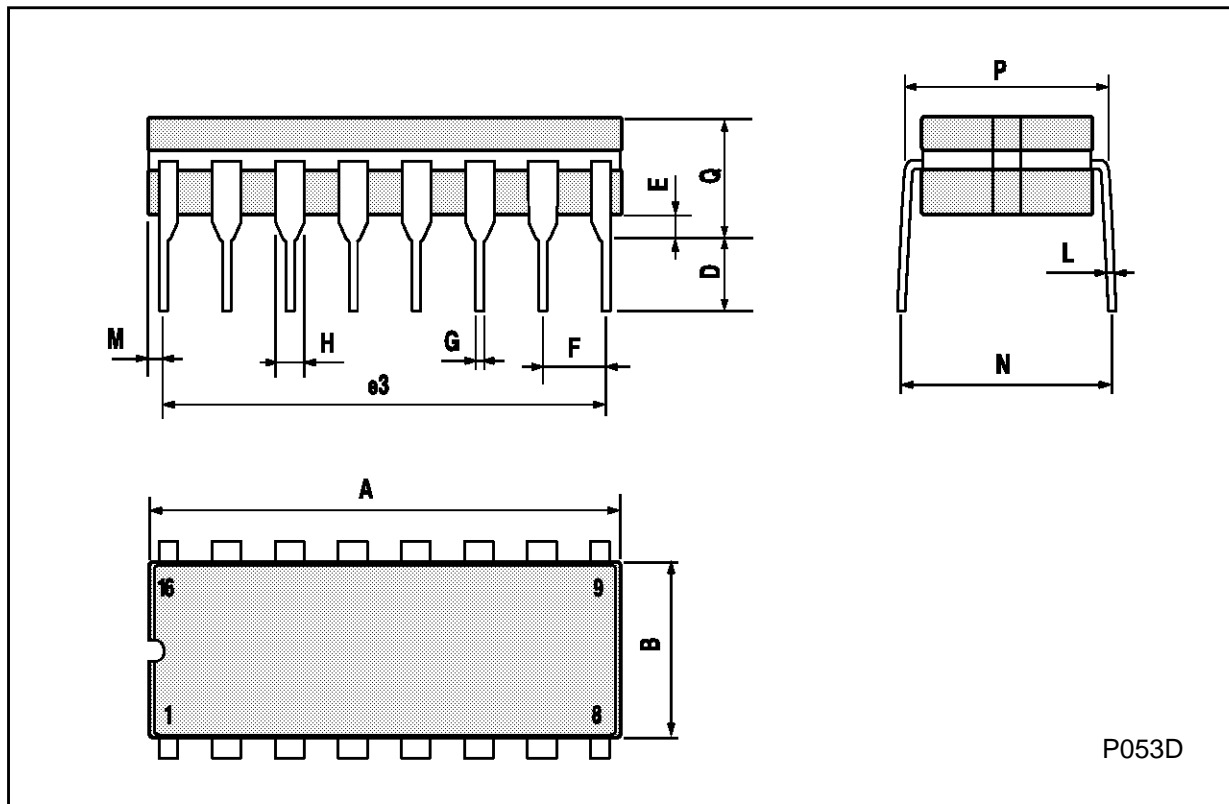

SO16 (Narrow) MECHANICAL DATA

DIM.	mm			inch		
	MIN.	TYP.	MAX.	MIN.	TYP.	MAX.
A			1.75			0.068
a1	0.1		0.2	0.004		0.007
a2			1.65			0.064
b	0.35		0.46	0.013		0.018
b1	0.19		0.25	0.007		0.010
C		0.5			0.019	
c1	45° (typ.)					
D	9.8		10	0.385		0.393
E	5.8		6.2	0.228		0.244
e		1.27			0.050	
e3		8.89			0.350	
F	3.8		4.0	0.149		0.157
G	4.6		5.3	0.181		0.208
L	0.5		1.27	0.019		0.050
M			0.62			0.024
S	8° (max.)					

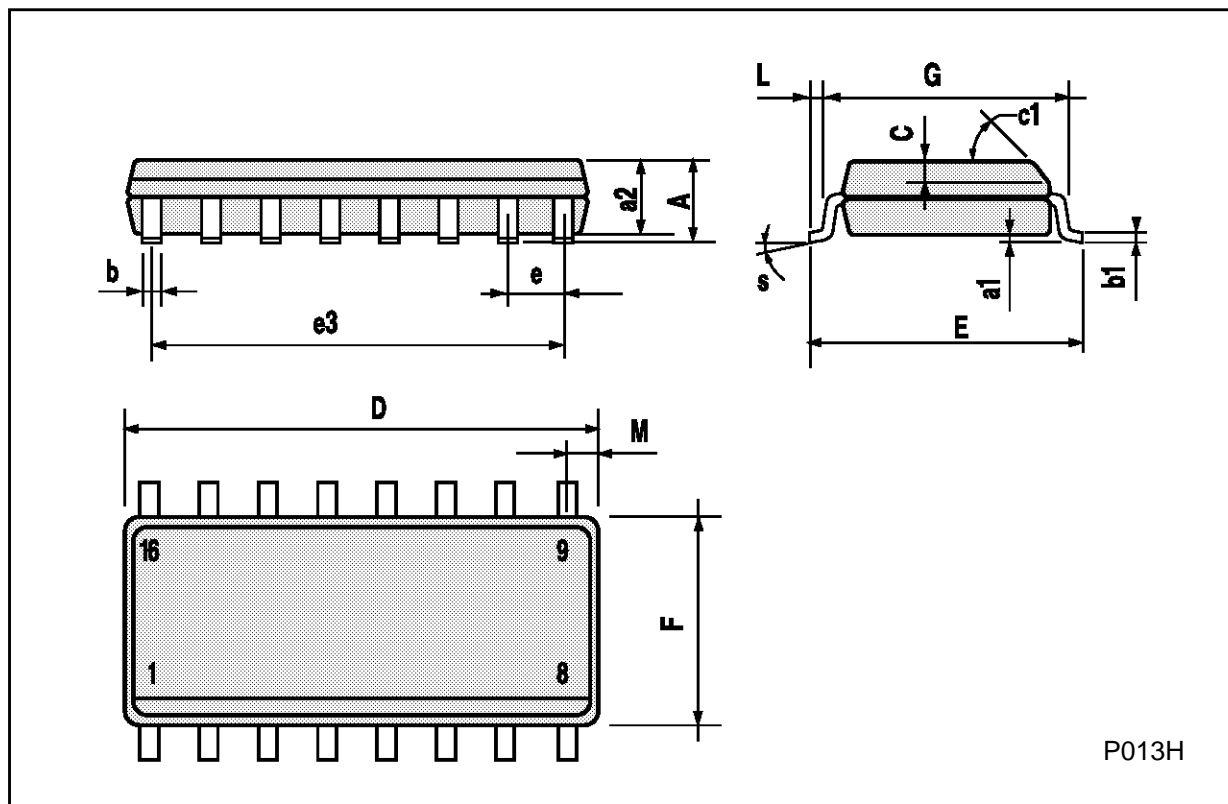

P013H

PLCC20 MECHANICAL DATA

DIM.	mm			inch		
	MIN.	TYP.	MAX.	MIN.	TYP.	MAX.
A	9.78		10.03	0.385		0.395
B	8.89		9.04	0.350		0.356
D	4.2		4.57	0.165		0.180
d1		2.54			0.100	
d2		0.56			0.022	
E	7.37		8.38	0.290		0.330
e		1.27			0.050	
e3		5.08			0.200	
F		0.38			0.015	
G			0.101			0.004
M		1.27			0.050	
M1		1.14			0.045	

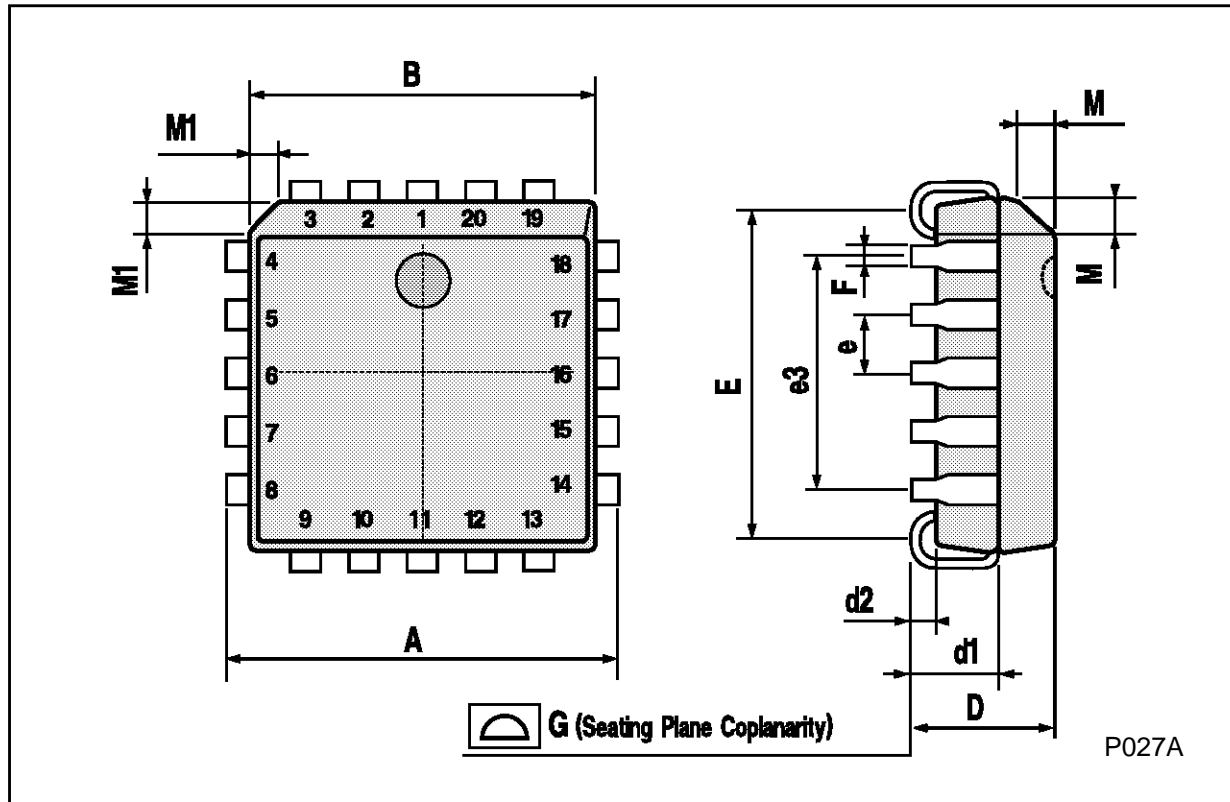

Information furnished is believed to be accurate and reliable. However, SGS-THOMSON Microelectronics assumes no responsibility for the consequences of use of such information nor for any infringement of patents or other rights of third parties which may result from its use. No license is granted by implication or otherwise under any patent or patent rights of SGS-THOMSON Microelectronics. Specifications mentioned in this publication are subject to change without notice. This publication supersedes and replaces all information previously supplied. SGS-THOMSON Microelectronics products are not authorized for use as critical components in life support devices or systems without express written approval of SGS-THOMSON Microelectronics.

© 1994 SGS-THOMSON Microelectronics - All Rights Reserved

SGS-THOMSON Microelectronics GROUP OF COMPANIES

Australia - Brazil - France - Germany - Hong Kong - Italy - Japan - Korea - Malaysia - Malta - Morocco - The Netherlands -
Singapore - Spain - Sweden - Switzerland - Taiwan - Thailand - United Kingdom - U.S.A