

**DECADE COUNTER/DIVIDER**

- HIGH SPEED  
 $t_{PD} = 21 \text{ ns (typ.) AT } V_{CC} = 5\text{V}$
- LOW POWER DISSIPATION  
 $I_{CC} = 4 \mu\text{A (MAX.) AT } T_A = 25 \text{ }^\circ\text{C}$
- HIGH NOISE IMMUNITY  
 $V_{NIH} = V_{NIL} = 28 \% V_{CC} \text{ (MIN.)}$
- OUTPUT DRIVE CAPABILITY  
 10 LSTTL LOADS
- SYMMETRICAL OUTPUT IMPEDANCE  
 $|I_{OH}| = I_{OL} = 4 \text{ mA (MIN.)}$
- BALANCED PROPAGATION DELAYS  
 $t_{PLH} = t_{PHL}$
- WIDE OPERATING VOLTAGE RANGE  
 $V_{CC} \text{ (OPR)} = 2 \text{ V TO } 6 \text{ V}$
- PIN AND FUNCTION COMPATIBLE WITH  
 4017B

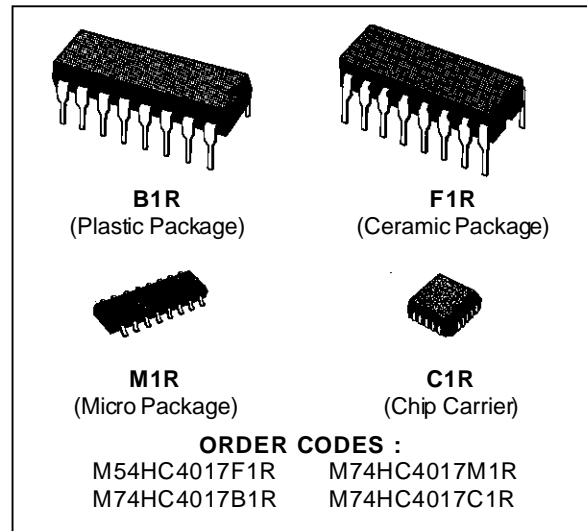

**DESCRIPTION**

The M54/74HC4017 is a high speed CMOS DECADE COUNTER/DIVIDER fabricated in silicon gate C2MOS technology. It has the same high speed performance of LSTTL combined with true CMOS low power consumption.

The M54/74HC4017 is a 5-stage Johnson counter with 10 decoded outputs. Each of the decoded outputs is normally low and sequentially goes high on the low to high transition of the clock input. Each output stays high for one clock period of the 10 clock period cycle. The CARRY output goes low to high after OUTPUT 10 goes low, and can be used in conjunction with the CLOCK ENABLE to cascade several stages.

The CLOCK ENABLE input disables counting when in the high state. A RESET input is also provided which when taken high sets all the decoded outputs low.

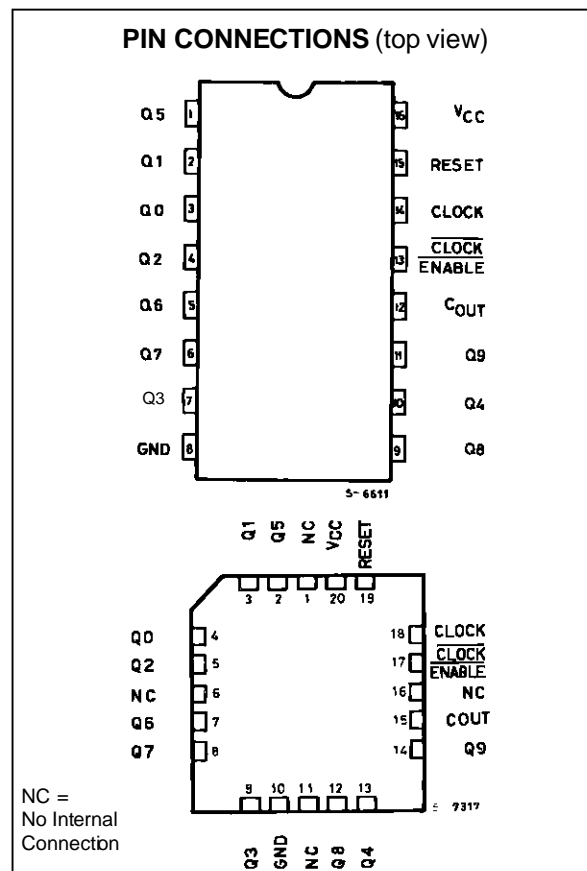

INPUT AND OUTPUT EQUIVALENT CIRCUIT



TRUTH TABLE

CLOCK	CLOCK ENABLE	CLEAR	DECODE OUTPUT (H)
X	X	H	Q0
L	X	L	Qn
X	H	L	Qn
	L	L	Qn + 1
	L	L	Qn
H		L	Qn
H		L	Qn + 1

X: DON'T CARE  
Qn: NO CHANGE

LOGIC DIAGRAM

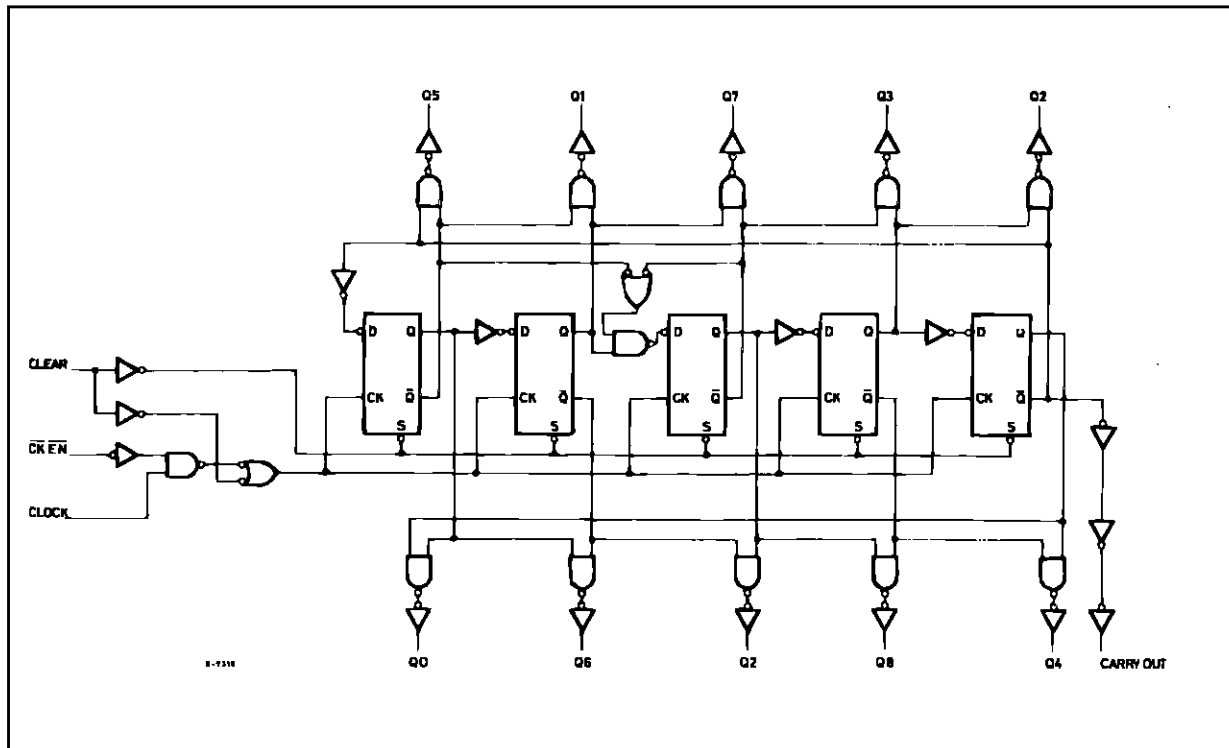

**TIMING DIAGRAM**

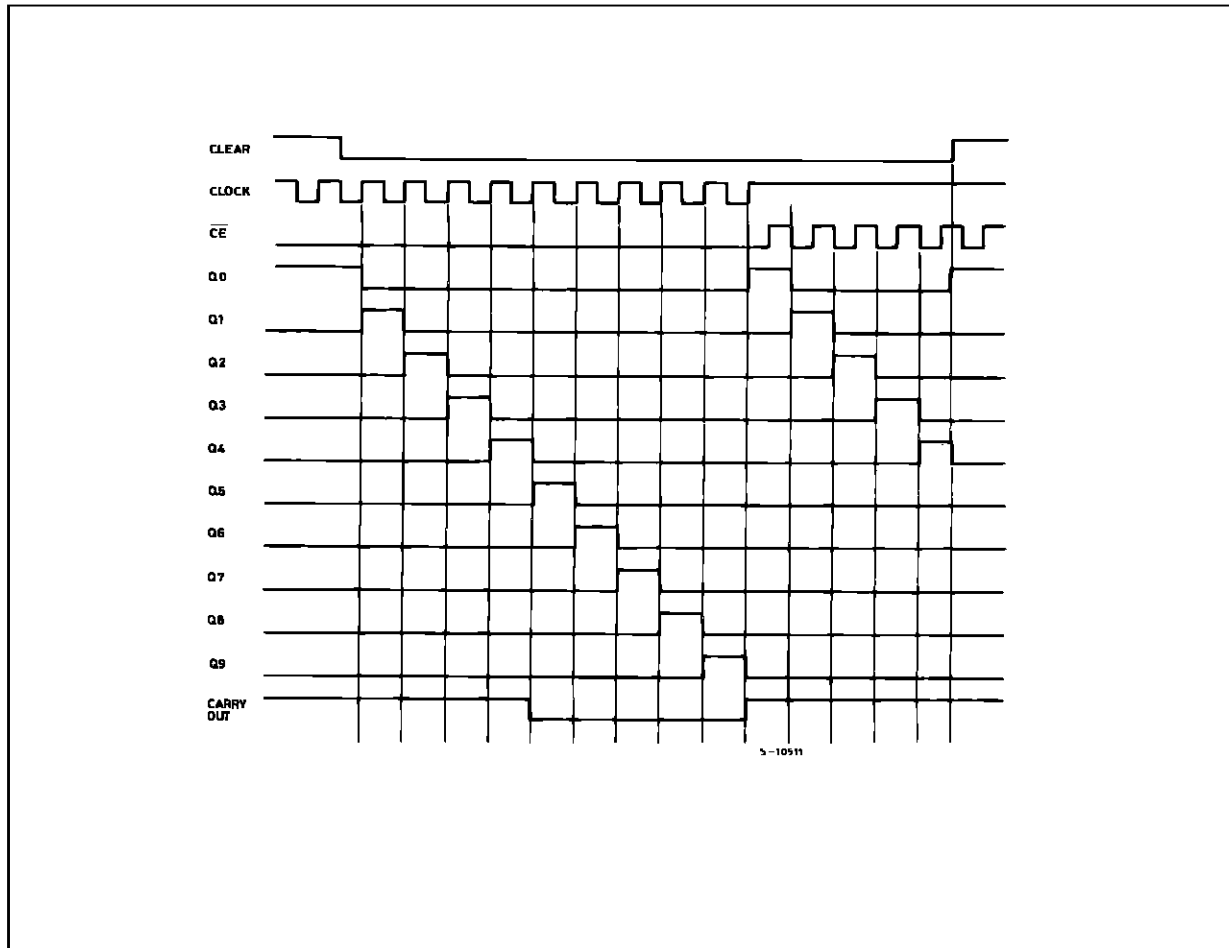

**PIN DESCRIPTION**

PIN No	SYMBOL	NAME AND FUNCTION
3, 2, 4, 7, 10, 1, 5, 6, 9, 11	Q0 to Q9	Decoded Outputs
12	C <sub>OUT</sub>	Carry Output (Active LOW)
13	$\overline{\text{CKEN}}$	Clock Enable Input (Active LOW)
14	CLOCK	Clock Input (LOW to HIGH, Edge-triggered)
15	RESET	Master Reset Input (Active HIGH)
8	GND	Ground (0V)
16	V <sub>CC</sub>	Positive Supply Voltage

**IEC LOGIC SYMBOL**

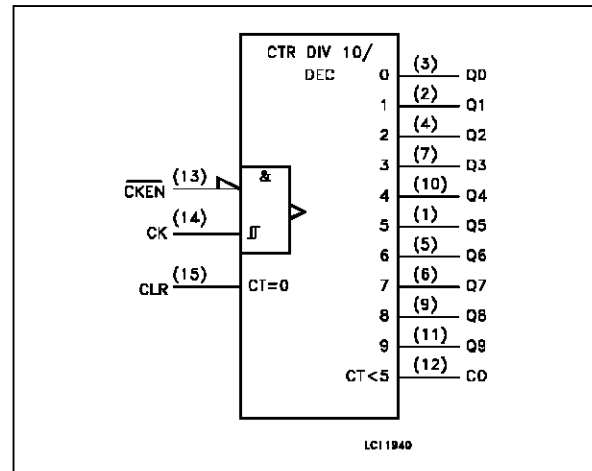

**ABSOLUTE MAXIMUM RATINGS**

Symbol	Parameter	Value	Unit
V <sub>CC</sub>	Supply Voltage	-0.5 to +7	V
V <sub>I</sub>	DC Input Voltage	-0.5 to V <sub>CC</sub> + 0.5	V
V <sub>O</sub>	DC Output Voltage	-0.5 to V <sub>CC</sub> + 0.5	V
I <sub>IK</sub>	DC Input Diode Current	± 20	mA
I <sub>OK</sub>	DC Output Diode Current	± 20	mA
I <sub>O</sub>	DC Output Source Sink Current Per Output Pin	± 25	mA
I <sub>CC</sub> or I <sub>GND</sub>	DC V <sub>CC</sub> or Ground Current	± 50	mA
P <sub>D</sub>	Power Dissipation	500 (*)	mW
T <sub>stg</sub>	Storage Temperature	-65 to +150	°C
T <sub>L</sub>	Lead Temperature (10 sec)	300	°C

Absolute Maximum Ratings are those values beyond which damage to the device may occur. Functional operation under these condition is not implied.

(\*) 500 mW: ≡ 65 °C derate to 300 mW by 10mW/°C: 65 °C to 85 °C

**RECOMMENDED OPERATING CONDITIONS**

Symbol	Parameter	Value	Unit	
V <sub>CC</sub>	Supply Voltage	2 to 6	V	
V <sub>I</sub>	Input Voltage	0 to V <sub>CC</sub>	V	
V <sub>O</sub>	Output Voltage	0 to V <sub>CC</sub>	V	
T <sub>op</sub>	Operating Temperature: <b>M54HC Series</b> <b>M74HC Series</b>	-55 to +125 -40 to +85	°C °C	
t <sub>r</sub> , t <sub>f</sub>	Input Rise and Fall Time	V <sub>CC</sub> = 2 V V <sub>CC</sub> = 4.5 V V <sub>CC</sub> = 6 V	0 to 1000 0 to 500 0 to 400	ns

## DC SPECIFICATIONS

Symbol	Parameter	Test Conditions		Value						Unit		
		V <sub>CC</sub> (V)		T <sub>A</sub> = 25 °C 54HC and 74HC			-40 to 85 °C 74HC		-55 to 125 °C 54HC			
				Min.	Typ.	Max.	Min.	Max.	Min.		Max.	
V <sub>IH</sub>	High Level Input Voltage	2.0		1.5			1.5		1.5		V	
		4.5		3.15			3.15		3.15			
		6.0		4.2			4.2		4.2			
V <sub>IL</sub>	Low Level Input Voltage	2.0				0.5		0.5		0.5	V	
		4.5				1.35		1.35		1.35		
		6.0				1.8		1.8		1.8		
V <sub>OH</sub>	High Level Output Voltage	2.0	V <sub>I</sub> = V <sub>IH</sub> or V <sub>IL</sub>	I <sub>O</sub> = -20 μA	1.9	2.0		1.9		1.9	V	
		4.5			4.4	4.5		4.4		4.4		
		6.0			5.9	6.0		5.9		5.9		
		4.5	I <sub>O</sub> = -4.0 mA	4.18	4.31		4.13		4.10			
		6.0		I <sub>O</sub> = -5.2 mA	5.68	5.8		5.63		5.60		
V <sub>OL</sub>	Low Level Output Voltage	2.0	V <sub>I</sub> = V <sub>IH</sub> or V <sub>IL</sub>	I <sub>O</sub> = 20 μA		0.0	0.1		0.1		0.1	V
		4.5				0.0	0.1		0.1		0.1	
		6.0				0.0	0.1		0.1		0.1	
		4.5		I <sub>O</sub> = 4.0 mA		0.17	0.26		0.33		0.40	
		6.0			I <sub>O</sub> = 5.2 mA		0.18	0.26		0.33		
I <sub>I</sub>	Input Leakage Current	6.0	V <sub>I</sub> = V <sub>CC</sub> or GND			±0.1		±1		±1	μA	
I <sub>CC</sub>	Quiescent Supply Current	6.0	V <sub>I</sub> = V <sub>CC</sub> or GND			4		40		80	μA	

## M54/M74HC4017

### AC ELECTRICAL CHARACTERISTICS (C<sub>L</sub> = 50 pF, Input t<sub>r</sub> = t<sub>f</sub> = 6 ns)

Symbol	Parameter	Test Conditions		Value						Unit	
		V <sub>CC</sub> (V)		T <sub>A</sub> = 25 °C 54HC and 74HC			-40 to 85 °C 74HC		-55 to 125 °C 54HC		
				Min.	Typ.	Max.	Min.	Max.	Min.		Max.
t <sub>TLH</sub> t <sub>THL</sub>	Output Transition Time	2.0			30	75		95		110	ns
		4.5			8	15		19		22	
		6.0			7	13		16		19	
t <sub>PLH</sub> t <sub>PHL</sub>	Propagation Delay Time (CK, CE - Q, C <sub>OUT</sub> )	2.0			100	195		245		295	ns
		4.5			25	39		49		59	
		6.0			21	33		42		50	
t <sub>PLH</sub> t <sub>PHL</sub>	Propagation Delay Time (CLEAR- Q, C <sub>OUT</sub> )	2.0			100	195		245		295	ns
		4.5			25	39		49		59	
		6.0			21	33		42		50	
f <sub>MAX</sub>	Maximum Clock Frequency	2.0		5	10		4		3.4		ns
		4.5		25	41		20		17		
		6.0		29	48		24		20		
t <sub>W(H)</sub> t <sub>W(L)</sub>	Minimum Pulse Width (CLOCK)	2.0			35	75		95		110	ns
		4.5			7	15		19		22	
		6.0			6	13		16		19	
t <sub>W(H)</sub>	Minimum Pulse Width (CLEAR)	2.0			35	75		95		110	ns
		4.5			7	15		19		22	
		6.0			6	13		16		19	
t <sub>s</sub>	Minimum Set-up Time	2.0			12	50		65		75	ns
		4.5			3	10		13		15	
		6.0			3	9		11		13	
t <sub>h</sub>	Minimum Hold Time	2.0			32	75		95		110	ns
		4.5			8	15		19		22	
		6.0			7	13		16		19	
t <sub>REM</sub>	Minimum Removal Time	2.0			28	75		95		110	ns
		4.5			7	15		19		22	
		6.0			6	13		16		19	
C <sub>IN</sub>	Input Capacitance				5	10		10		10	pF
C <sub>PD</sub> (*)	Power Dissipation Capacitance				41						pF

(\*) C<sub>PD</sub> is defined as the value of the IC's internal equivalent capacitance which is calculated from the operating current consumption without load. (Refer to Test Circuit). Average operating current can be obtained by the following equation. I<sub>CC(OPR)</sub> = C<sub>PD</sub> • V<sub>CC</sub> • f<sub>IN</sub> + I<sub>CC</sub>

SWITCHING CHARACTERISTICS TEST WAVEFORM

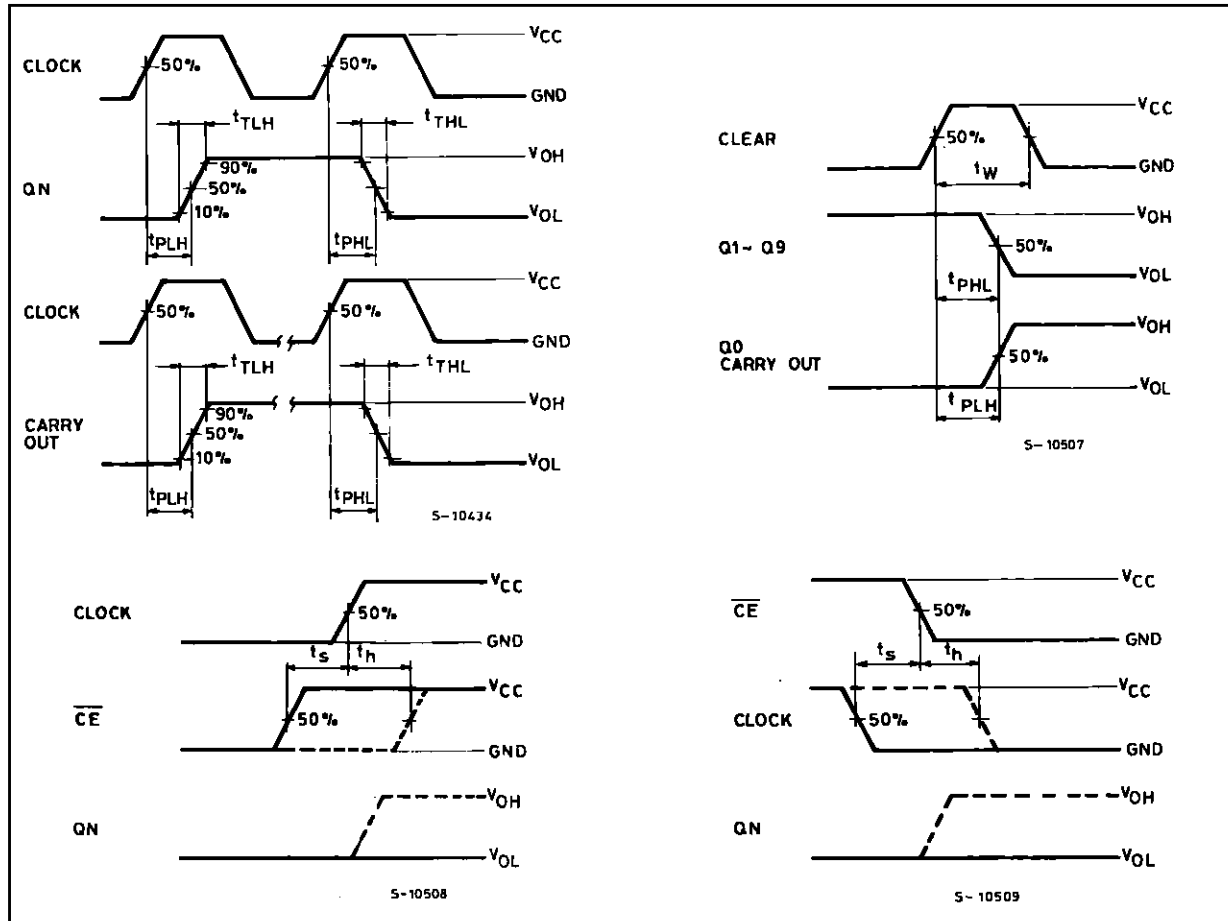

TEST CIRCUIT  $I_{CC}$  (Opr.)

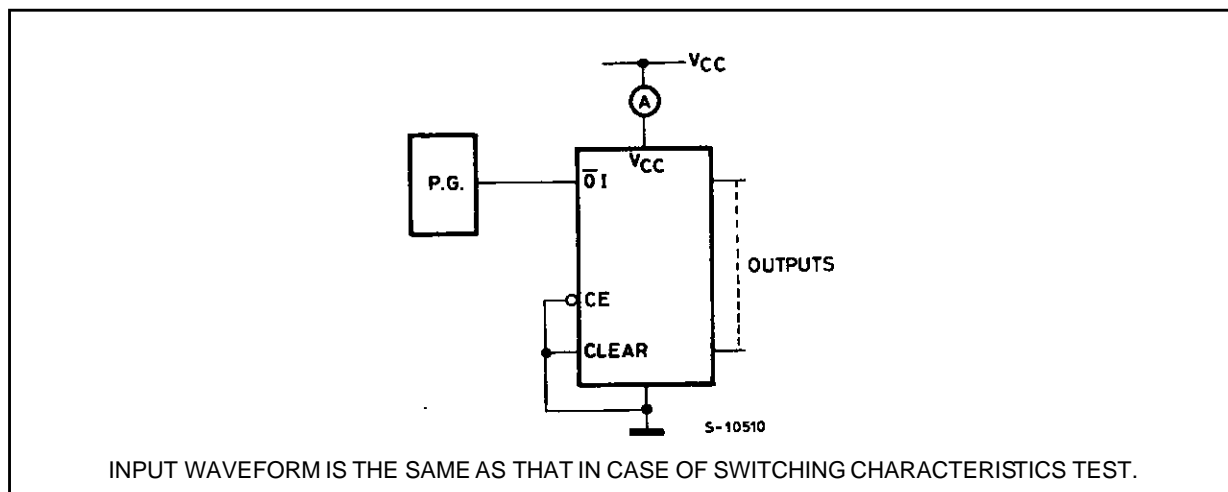

INPUT WAVEFORM IS THE SAME AS THAT IN CASE OF SWITCHING CHARACTERISTICS TEST.

**Plastic DIP16 (0.25) MECHANICAL DATA**

DIM.	mm			inch		
	MIN.	TYP.	MAX.	MIN.	TYP.	MAX.
a1	0.51			0.020		
B	0.77		1.65	0.030		0.065
b		0.5			0.020	
b1		0.25			0.010	
D			20			0.787
E		8.5			0.335	
e		2.54			0.100	
e3		17.78			0.700	
F			7.1			0.280
I			5.1			0.201
L		3.3			0.130	
Z			1.27			0.050



## Ceramic DIP16/1 MECHANICAL DATA

DIM.	mm			inch		
	MIN.	TYP.	MAX.	MIN.	TYP.	MAX.
A			20			0.787
B			7			0.276
D		3.3			0.130	
E	0.38			0.015		
e3		17.78			0.700	
F	2.29		2.79	0.090		0.110
G	0.4		0.55	0.016		0.022
H	1.17		1.52	0.046		0.060
L	0.22		0.31	0.009		0.012
M	0.51		1.27	0.020		0.050
N			10.3			0.406
P	7.8		8.05	0.307		0.317
Q			5.08			0.200

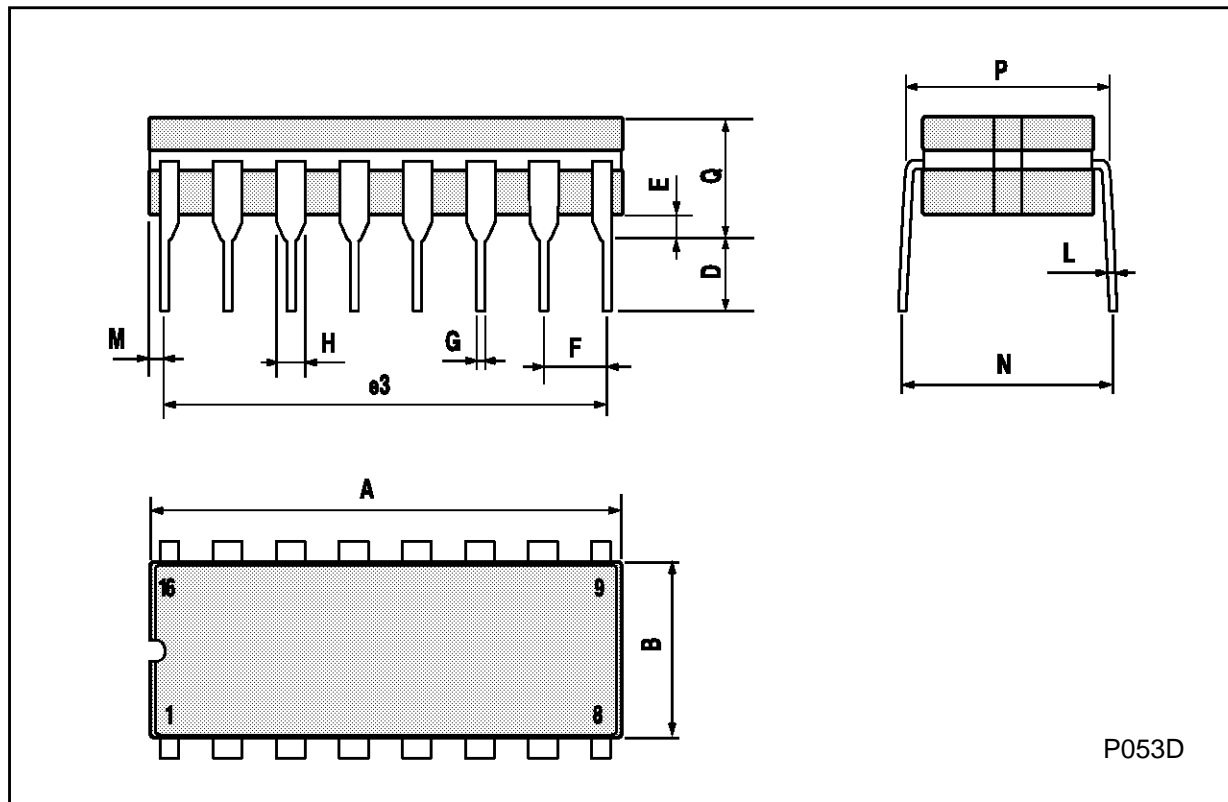

SO16 (Narrow) MECHANICAL DATA

DIM.	mm			inch		
	MIN.	TYP.	MAX.	MIN.	TYP.	MAX.
A			1.75			0.068
a1	0.1		0.2	0.004		0.007
a2			1.65			0.064
b	0.35		0.46	0.013		0.018
b1	0.19		0.25	0.007		0.010
C		0.5			0.019	
c1	45° (typ.)					
D	9.8		10	0.385		0.393
E	5.8		6.2	0.228		0.244
e		1.27			0.050	
e3		8.89			0.350	
F	3.8		4.0	0.149		0.157
G	4.6		5.3	0.181		0.208
L	0.5		1.27	0.019		0.050
M			0.62			0.024
S	8° (max.)					



P013H

## PLCC20 MECHANICAL DATA

DIM.	mm			inch		
	MIN.	TYP.	MAX.	MIN.	TYP.	MAX.
A	9.78		10.03	0.385		0.395
B	8.89		9.04	0.350		0.356
D	4.2		4.57	0.165		0.180
d1		2.54			0.100	
d2		0.56			0.022	
E	7.37		8.38	0.290		0.330
e		1.27			0.050	
e3		5.08			0.200	
F		0.38			0.015	
G			0.101			0.004
M		1.27			0.050	
M1		1.14			0.045	

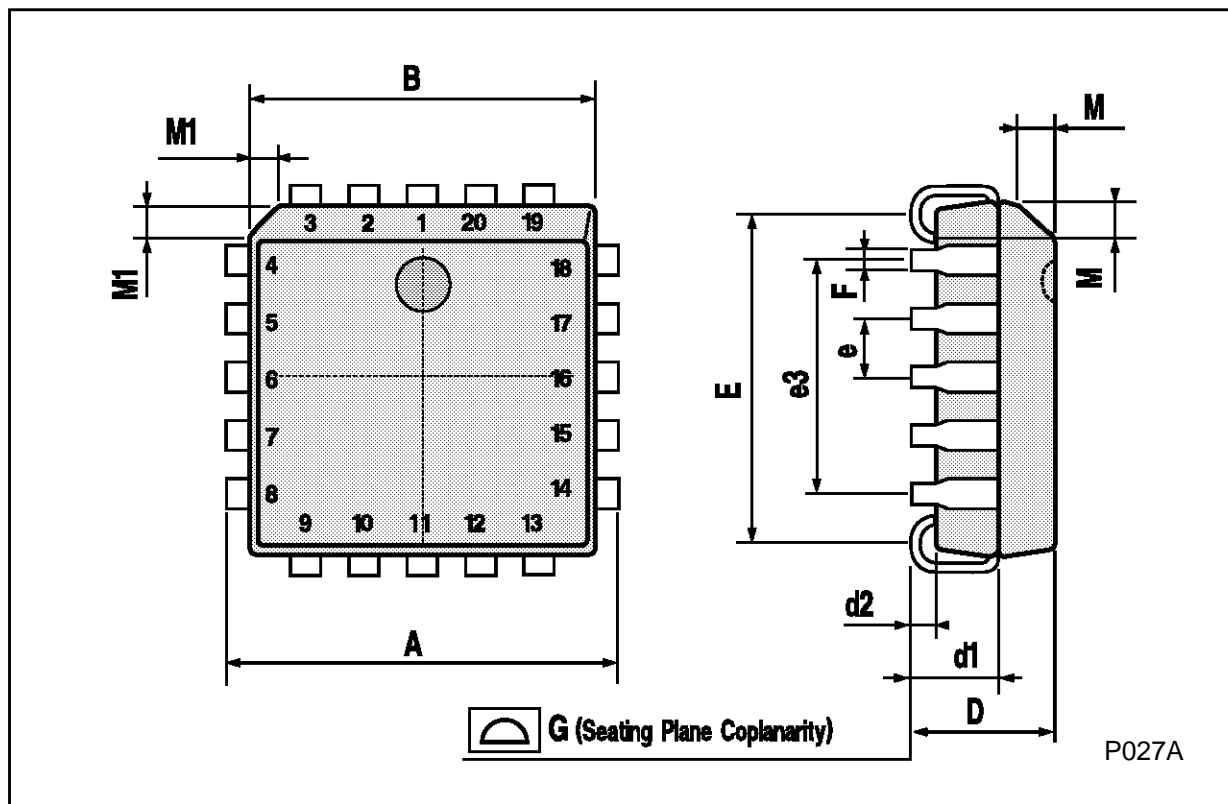

Information furnished is believed to be accurate and reliable. However, SGS-THOMSON Microelectronics assumes no responsibility for the consequences of use of such information nor for any infringement of patents or other rights of third parties which may result from its use. No license is granted by implication or otherwise under any patent or patent rights of SGS-THOMSON Microelectronics. Specifications mentioned in this publication are subject to change without notice. This publication supersedes and replaces all information previously supplied. SGS-THOMSON Microelectronics products are not authorized for use as critical components in life support devices or systems without express written approval of SGS-THOMSON Microelectronics.

© 1994 SGS-THOMSON Microelectronics - All Rights Reserved

SGS-THOMSON Microelectronics GROUP OF COMPANIES

Australia - Brazil - France - Germany - Hong Kong - Italy - Japan - Korea - Malaysia - Malta - Morocco - The Netherlands -  
Singapore - Spain - Sweden - Switzerland - Taiwan - Thailand - United Kingdom - U.S.A