

HC4049 HEX BUFFER/CONVERTER (INVERTER)

HC4050 HEX BUFFER/CONVERTER

- HIGH SPEED
 $t_{PD} = 9 \text{ ns}$ (TYP.) AT $V_{CC} = 5 \text{ V}$
- LOW POWER DISSIPATION
 $I_{CC} = 1 \mu\text{A}$ (MAX.) AT $T_A = 25 \text{ }^\circ\text{C}$
- HIGH NOISE IMMUNITY
 $V_{NIH} = V_{NIL} = 28 \% V_{CC}$ (MIN.)
- OUTPUT DRIVE CAPABILITY
 15 LSTTL LOADS
- SYMMETRICAL OUTPUT IMPEDANCE
 $|I_{OH}| = I_{OL} = 6 \text{ mA}$ (MIN.)
- BALANCED PROPAGATION DELAYS
 $t_{PLH} = t_{PHL}$
- WIDE OPERATING VOLTAGE RANGE
 $V_{CC} \text{ (OPR)} = 2 \text{ V TO } 6 \text{ V}$
- PIN AND FUNCTION COMPATIBLE
 WITH 4049B/4050B

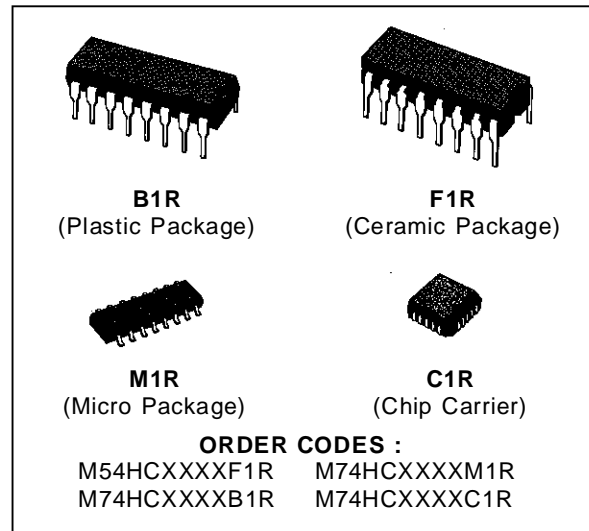

DESCRIPTION

The M54/74HC4049 and the M54/74HC4050 are high speed CMOS HEX BUFFER fabricated in silicon gate C²MOS technology.

They have the same high speed performance of LSTTL combined with true CMOS low power consumption.

The M54/75HC4049 is an inverting buffer, while the M54/74HC4050 is a non-inverting buffer.

The internal circuit is composed of 3 stage or 2-stage inverters, which provides high noise immunity and a stable output.

Input protection circuits are different from those of the high speed CMOS IC's.

The VCC side diodes are designed to allow logic-level conversion from high-level voltages (up to 15 V) to low-level voltages.

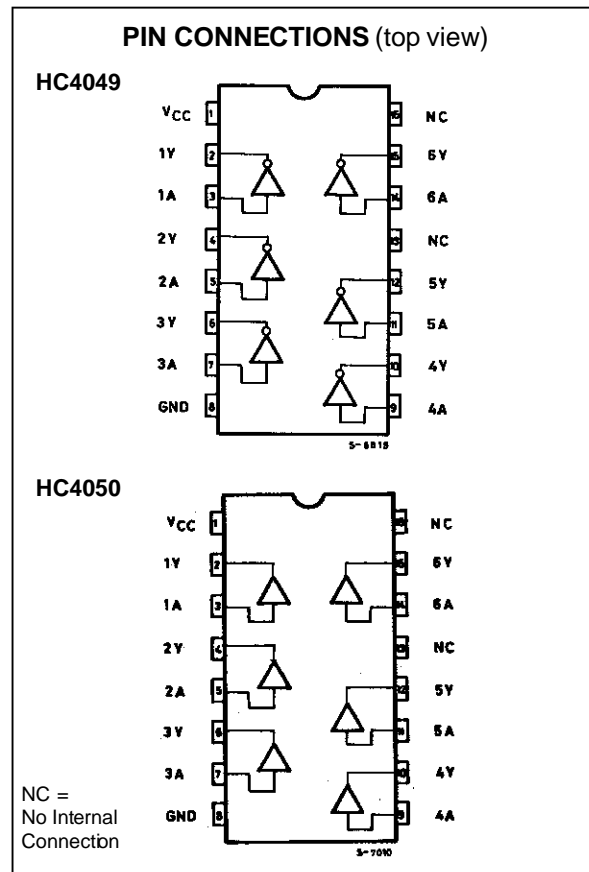

M54/M74HC4049/4050

CIRCUIT SCHEMATIC (Per Gate)

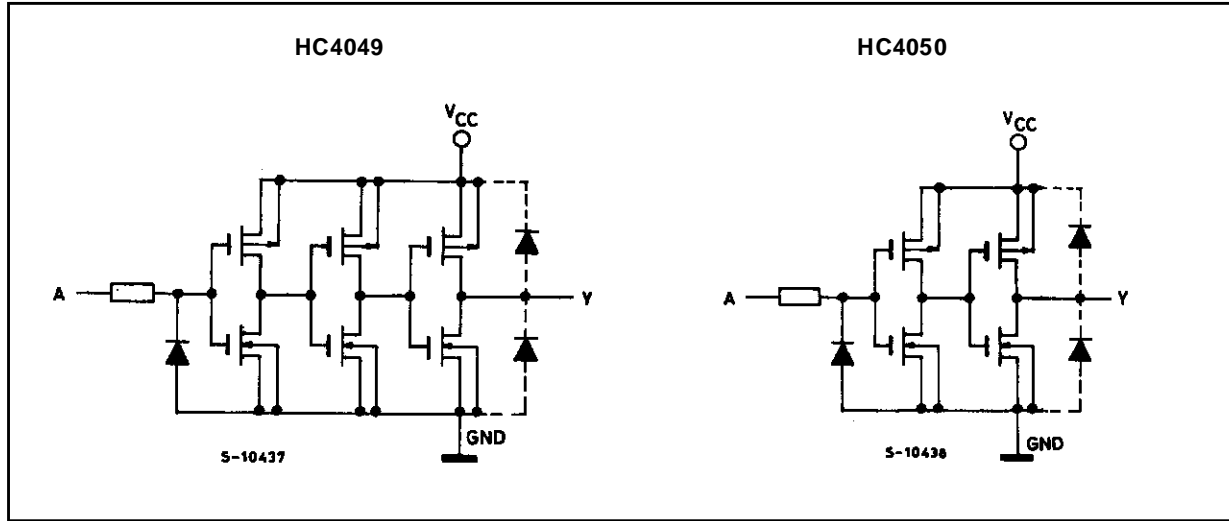

CHIP CARRIER

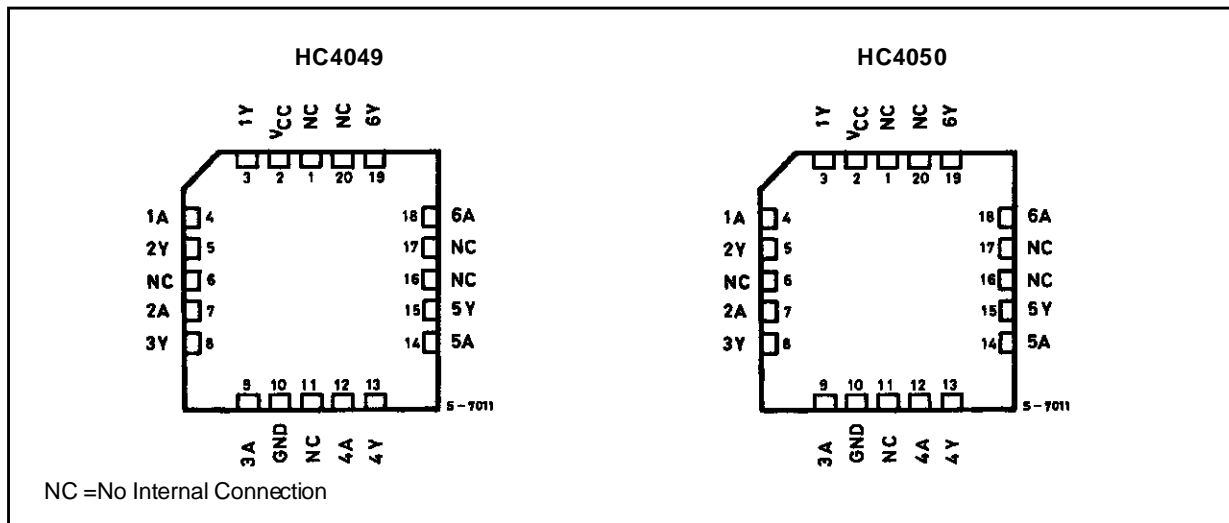

TRUTH TABLE (HC4049)

INPUT	OUTPUT
nA	n \bar{Y}
L	H
H	L

TRUTH TABLE (HC4050)

INPUT	OUTPUT
nA	nY
L	L
H	H

PIN DESCRIPTION (HC4049)

PIN No	SYMBOL	NAME AND FUNCTION
2, 4, 6, 10, 12, 15	1 \bar{Y} to 6 \bar{Y}	Data Outputs
3, 5, 7, 9, 11, 14	1A to 6A	Data Inputs
13, 16	NC	Not Connected
8	GND	Ground (0V)
1	V _{CC}	Positive Supply Voltage

PIN DESCRIPTION (HC4050)

PIN No	SYMBOL	NAME AND FUNCTION
2, 4, 6, 10, 12, 15	1Y to 6Y	Data Outputs
3, 5, 7, 9, 11, 14	1A to 6A	Data Inputs
13, 16	NC	Not Connected
8	GND	Ground (0V)
1	V _{CC}	Positive Supply Voltage

IEC LOGIC SYMBOLS

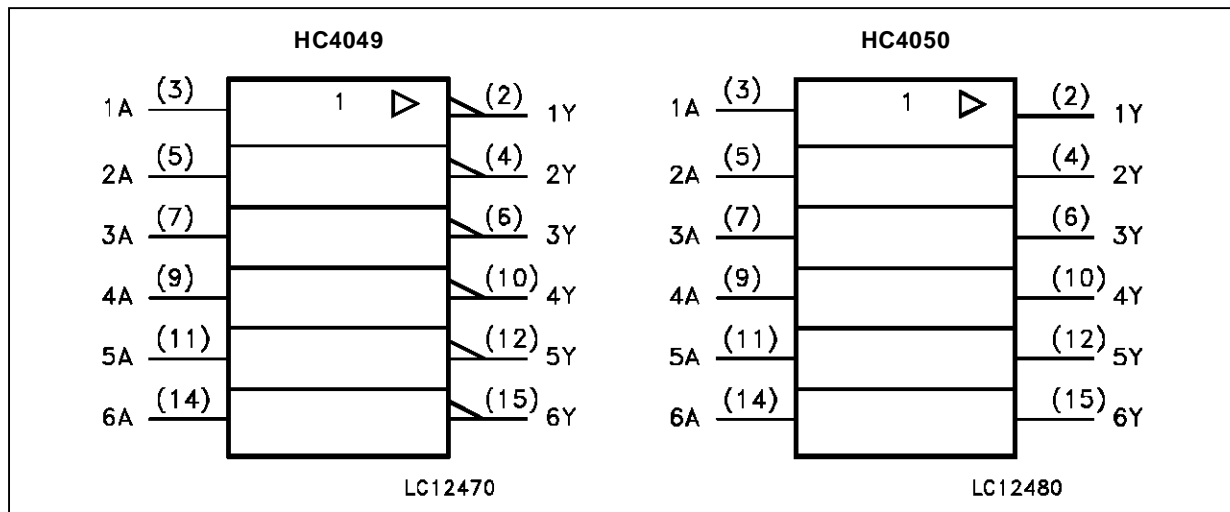

ABSOLUTE MAXIMUM RATINGS

Symbol	Parameter	Value	Unit
V _{CC}	Supply Voltage	-0.5 to +7	V
V _I	DC Input Voltage	-0.5 to V _{CC} + 0.5	V
V _O	DC Output Voltage	-0.5 to V _{CC} + 0.5	V
I _{IK}	DC Input Diode Current	± 20	mA
I _{OK}	DC Output Diode Current	± 20	mA
I _O	DC Output Source Sink Current Per Output Pin	± 25	mA
I _{CC} or I _{GND}	DC V _{CC} or Ground Current	± 50	mA
P _D	Power Dissipation	500 (*)	mW
T _{stg}	Storage Temperature	-65 to +150	°C
T _L	Lead Temperature (10 sec)	300	°C

Absolute Maximum Ratings are those values beyond which damage to the device may occur. Functional operation under these condition is not implied.

(*) 500 mW: ≙ 65 °C derate to 300 mW by 10mW/°C: 65 °C to 85 °C

RECOMMENDED OPERATING CONDITIONS

Symbol	Parameter	Value	Unit	
V _{CC}	Supply Voltage	2 to 6	V	
V _I	Input Voltage	0 to V _{CC}	V	
V _O	Output Voltage	0 to V _{CC}	V	
T _{op}	Operating Temperature: M54HC Series M74HC Series	-55 to +125 -40 to +85	°C °C	
t _r , t _f	Input Rise and Fall Time	V _{CC} = 2 V	0 to 1000	ns
		V _{CC} = 4.5 V	0 to 500	
		V _{CC} = 6 V	0 to 400	

DC SPECIFICATIONS

Symbol	Parameter	Test Conditions		Value						Unit	
		V _{CC} (V)		T _A = 25 °C 54HC and 74HC			-40 to 85 °C 74HC		-55 to 125 °C 54HC		
				Min.	Typ.	Max.	Min.	Max.	Min.		Max.
V _{IH}	High Level Input Voltage	2.0		1.5			1.5		1.5		V
		4.5		3.15			3.15		3.15		
		6.0		4.2			4.2		4.2		
V _{IL}	Low Level Input Voltage	2.0				0.5		0.5		0.5	V
		4.5				1.35		1.35		1.35	
		6.0				1.8		1.8		1.8	
V _{OH}	High Level Output Voltage	2.0	V _I = V _{IH} or V _{IL} I _O = -20 μA	1.9	2.0		1.9		1.9		V
		4.5		4.4	4.5		4.4		4.4		
		6.0		5.9	6.0		5.9		5.9		
		4.5	I _O = -6.0 mA	4.18	4.31		4.13		4.10		
		6.0		I _O = -7.8 mA	5.68	5.8		5.63		5.60	
V _{OL}	Low Level Output Voltage	2.0	V _I = V _{IH} or V _{IL} I _O = 20 μA		0.0	0.1		0.1		0.1	V
		4.5		0.0	0.1		0.1		0.1		
		6.0		0.0	0.1		0.1		0.1		
		4.5	I _O = 6.0 mA	0.17	0.26		0.33		0.40		
		6.0		I _O = 7.8 mA	0.18	0.26		0.33		0.40	
I _I	Input Leakage Current	6.0	V _I = V _{CC} or GND V _I = 15 V			±0.1 ±0.5		±1 ±5		±1	μA
I _{CC}	Quiescent Supply Current	6.0	V _I = V _{CC} or GND			1		10		20	μA

AC ELECTRICAL CHARACTERISTICS (C_L = 50 pF, Input t_r = t_f = 6 ns)

Symbol	Parameter	Test Conditions		Value						Unit	
		V _{CC} (V)	C _L (pF)	T _A = 25 °C 54HC and 74HC			-40 to 85 °C 74HC		-55 to 125 °C 54HC		
				Min.	Typ.	Max.	Min.	Max.	Min.		Max.
t _{TLH} t _{THL}	Output Transition Time	2.0	50		25	60		75		90	ns
		4.5		7	12		15		18		
		6.0		6	10		13		15		
t _{PLH} t _{PHL}	Propagation Delay Time	2.0	50		30	75		95		115	ns
		4.5		9	15		19		23		
		6.0		8	13		16		20		
		2.0	150		45	100		125		150	ns
		4.5		14	20		25		30		
		6.0		12	17		21		26		
C _{IN}	Input Capacitance				5	10		10		10	pF
C _{PD} (*)	Power Dissipation Capacitance				26						pF

C_{PD} is defined as the value of the IC's internal equivalent capacitance which is calculated from the operating current consumption without load. (Refer to Test Circuit). Average operating current can be obtained by the following equation. I_{CC(opr)} = C_{PD} • V_{CC} • f_{IN} + I_{CC} (per Gate)

SWITCHING CHARACTERISTICS TEST WAVEFORM

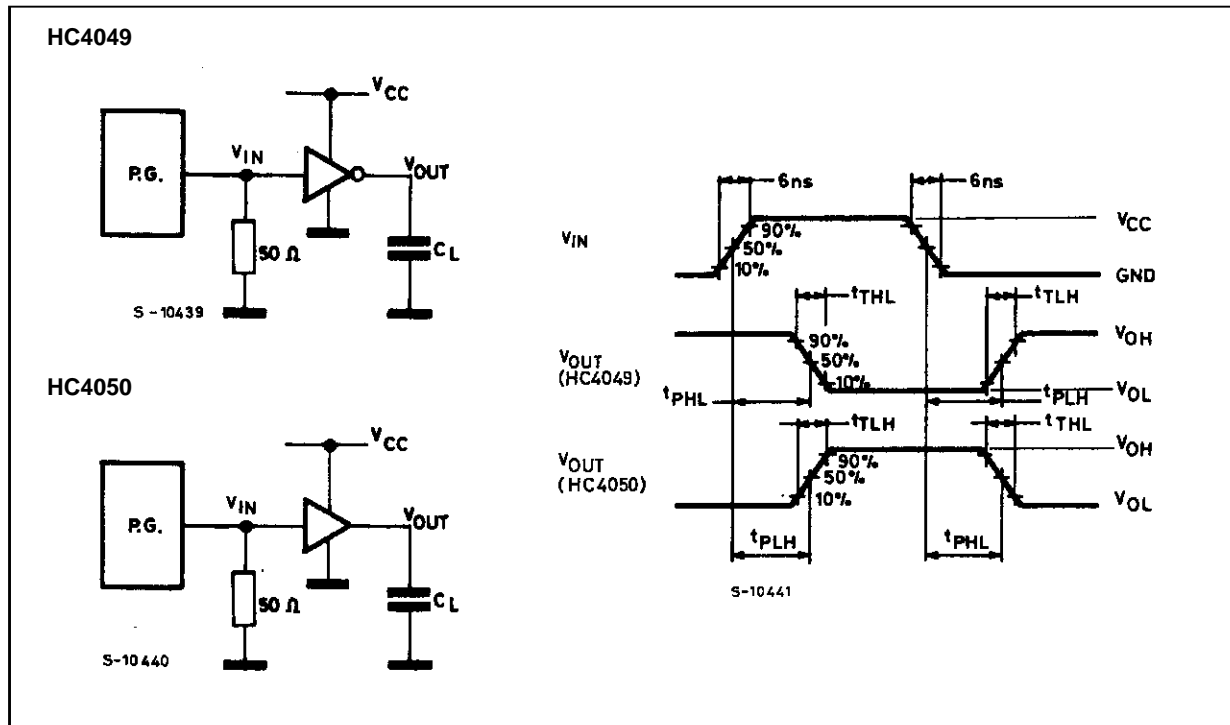

TEST CIRCUIT I_{CC} (Opr.)

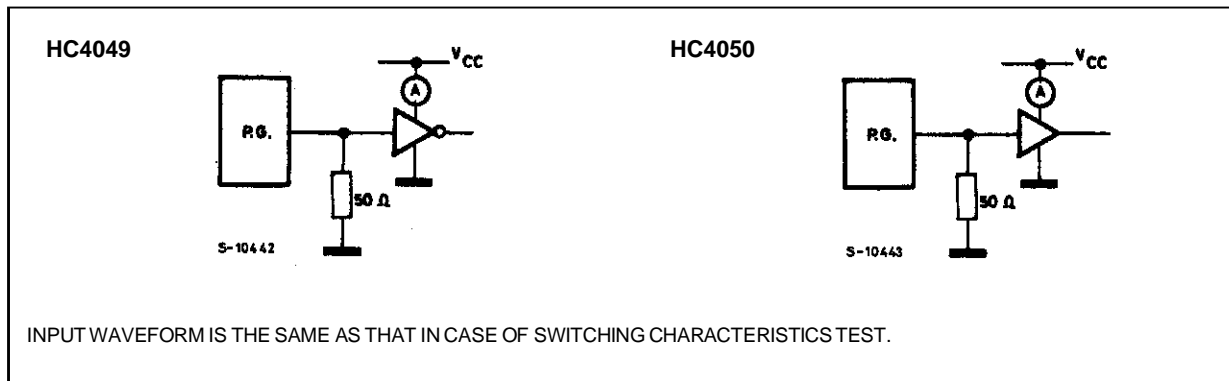

Plastic DIP16 (0.25) MECHANICAL DATA

DIM.	mm			inch		
	MIN.	TYP.	MAX.	MIN.	TYP.	MAX.
a1	0.51			0.020		
B	0.77		1.65	0.030		0.065
b		0.5			0.020	
b1		0.25			0.010	
D			20			0.787
E		8.5			0.335	
e		2.54			0.100	
e3		17.78			0.700	
F			7.1			0.280
I			5.1			0.201
L		3.3			0.130	
Z			1.27			0.050

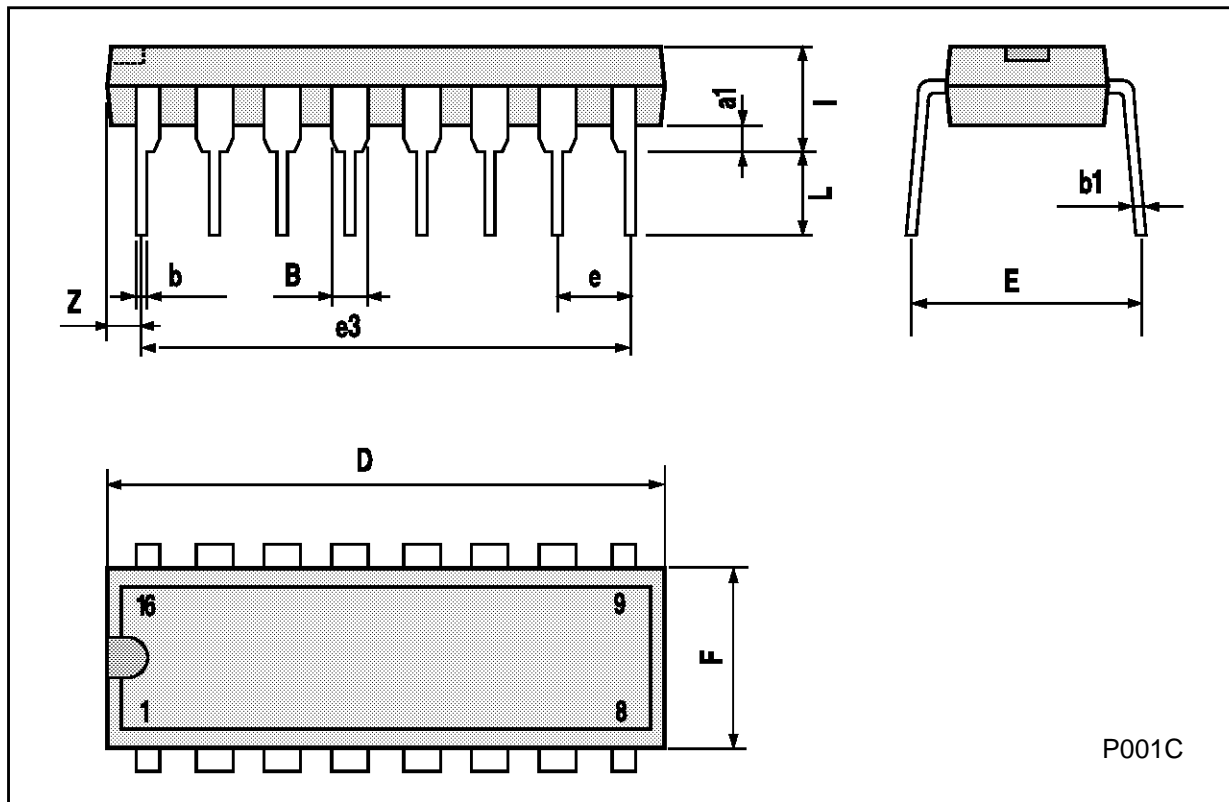

Ceramic DIP16/1 MECHANICAL DATA

DIM.	mm			inch		
	MIN.	TYP.	MAX.	MIN.	TYP.	MAX.
A			20			0.787
B			7			0.276
D		3.3			0.130	
E	0.38			0.015		
e3		17.78			0.700	
F	2.29		2.79	0.090		0.110
G	0.4		0.55	0.016		0.022
H	1.17		1.52	0.046		0.060
L	0.22		0.31	0.009		0.012
M	0.51		1.27	0.020		0.050
N			10.3			0.406
P	7.8		8.05	0.307		0.317
Q			5.08			0.200

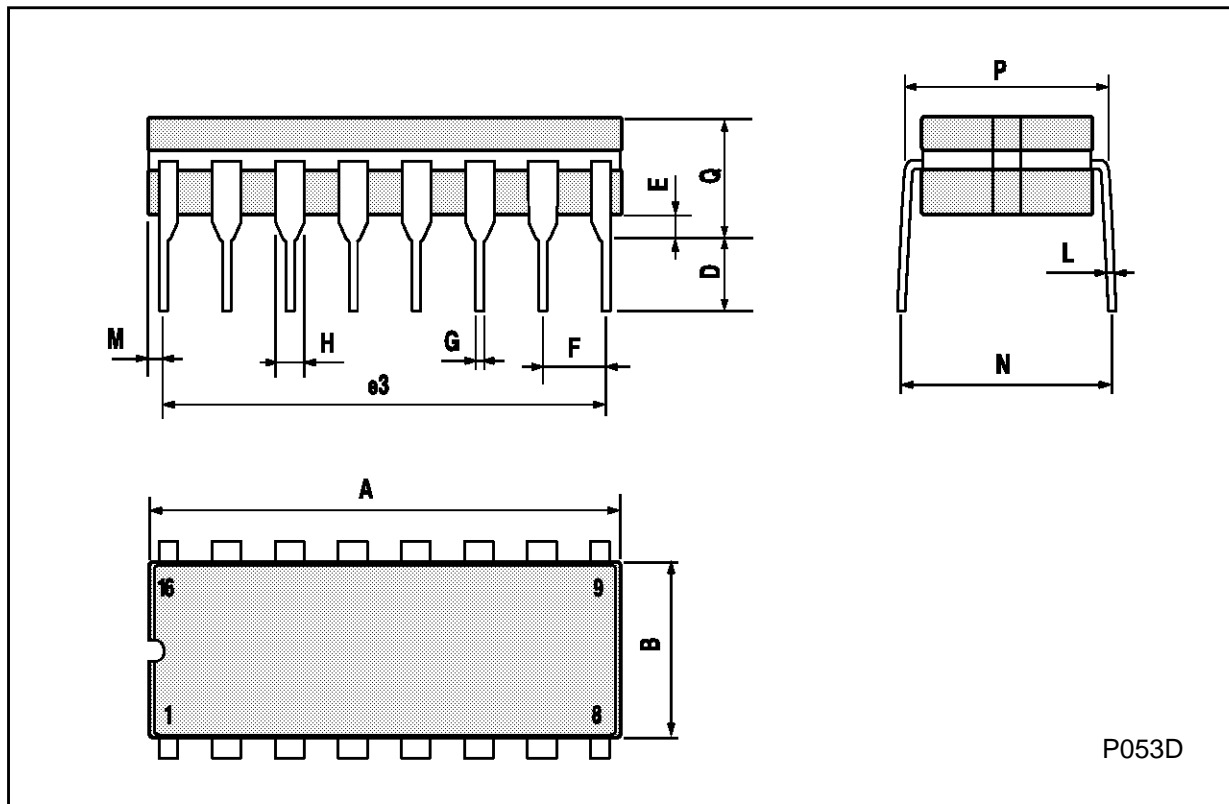

SO16 (Narrow) MECHANICAL DATA

DIM.	mm			inch		
	MIN.	TYP.	MAX.	MIN.	TYP.	MAX.
A			1.75			0.068
a1	0.1		0.2	0.004		0.007
a2			1.65			0.064
b	0.35		0.46	0.013		0.018
b1	0.19		0.25	0.007		0.010
C		0.5			0.019	
c1	45° (typ.)					
D	9.8		10	0.385		0.393
E	5.8		6.2	0.228		0.244
e		1.27			0.050	
e3		8.89			0.350	
F	3.8		4.0	0.149		0.157
G	4.6		5.3	0.181		0.208
L	0.5		1.27	0.019		0.050
M			0.62			0.024
S	8° (max.)					

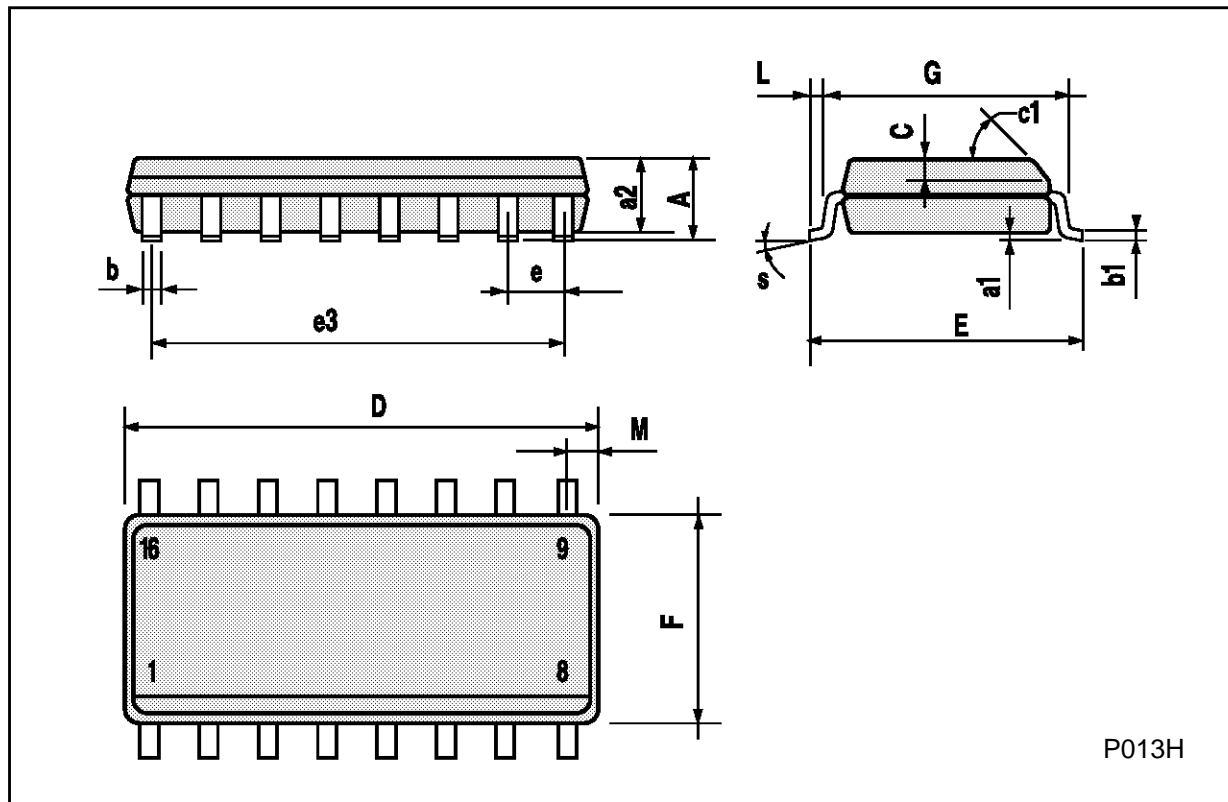

P013H

PLCC20 MECHANICAL DATA

DIM.	mm			inch		
	MIN.	TYP.	MAX.	MIN.	TYP.	MAX.
A	9.78		10.03	0.385		0.395
B	8.89		9.04	0.350		0.356
D	4.2		4.57	0.165		0.180
d1		2.54			0.100	
d2		0.56			0.022	
E	7.37		8.38	0.290		0.330
e		1.27			0.050	
e3		5.08			0.200	
F		0.38			0.015	
G			0.101			0.004
M		1.27			0.050	
M1		1.14			0.045	



Information furnished is believed to be accurate and reliable. However, SGS-THOMSON Microelectronics assumes no responsibility for the consequences of use of such information nor for any infringement of patents or other rights of third parties which may result from its use. No license is granted by implication or otherwise under any patent or patent rights of SGS-THOMSON Microelectronics. Specifications mentioned in this publication are subject to change without notice. This publication supersedes and replaces all information previously supplied. SGS-THOMSON Microelectronics products are not authorized for use as critical components in life support devices or systems without express written approval of SGS-THOMSON Microelectronics.

© 1994 SGS-THOMSON Microelectronics - All Rights Reserved

SGS-THOMSON Microelectronics GROUP OF COMPANIES

Australia - Brazil - France - Germany - Hong Kong - Italy - Japan - Korea - Malaysia - Malta - Morocco - The Netherlands -
Singapore - Spain - Sweden - Switzerland - Taiwan - Thailand - United Kingdom - U.S.A